



Town of Cheektowaga

Work Session

~ Minutes ~

3301 Broadway
Cheektowaga, NY 14227
<http://www.town.cheektowaga.ny.us>

Alice Magierski
716-686-3400

Thursday, January 2, 2014

6:00 PM

Council Office

I. Call to Order

6:00 PM Meeting called to order on January 2, 2014 at Council Office, Conference Room, Cheektowaga, NY.

Attendee Name	Organization	Title	Status	Arrived
Mary Holtz	Town of Cheektowaga	Supervisor	Present	
James P. Rogowski	Town of Cheektowaga	Councilmember	Present	
Charles Markel	Town of Cheektowaga	Councilmember	Present	
Gerald Kaminski	Town of Cheektowaga	Councilmember	Present	
Angela M. Wozniak	Town of Cheektowaga	Councilmember	Present	
Diane Benczkowski	Town of Cheektowaga	Councilmember	Present	
Timothy J. Meyers	Town of Cheektowaga	Councilmember	Present	

2. Additional Attendees

Brian Krause, Director of Finance and Administration
Anthony Romano, Coordinator of Employee Relations
Kevin Schenk, Town Attorney
Arthur Herdzik, Esq. Of Chelus, Herdzik, Speyer & Monte, PC

3. Motion To: Enter Into Executive Session at 6:00 PM

COMMENTS - Current Meeting:

To Discuss: Litigation Matters and matters relating to the discipline, hiring/termination/appointment of employees. Motioned Carried

RESULT: ADOPTED [UNANIMOUS]
MOVER: Mary Holtz, Supervisor
SECONDER: Charles Markel, Councilmember
AYES: Holtz, Rogowski, Markel, Kaminski, Wozniak, Benczkowski, Meyers

4. Motion To: Exit Executive Session at 6:23 PM

RESULT: ADOPTED [UNANIMOUS]
MOVER: Mary Holtz, Supervisor
SECONDER: Gerald Kaminski, Councilmember
AYES: Holtz, Rogowski, Markel, Kaminski, Wozniak, Benczkowski, Meyers

II. Resolutions



1. RESOLUTION 2014-1

Settlement of Claim - Accident on September 14, 2012

Sponsored By: Mary Holtz, Gerald Kaminski

WHEREAS, on or about June 14, 2012, a Town of Cheektowaga Highway Department truck accidentally struck a vehicle that was traveling southbound on Harlem Road near Daniel Drive in the Town of Cheektowaga, and

WHEREAS, the Town's outside counsel, Chelus, Herdzik, Speyer & Monte, P.C. litigated this claim, and negotiated a settlement with the claimant, and

WHEREAS, this settlement is in the best interests of the Town of Cheektowaga;

NOW THEREFORE, BE IT

RESOLVED, that the Town Board approves of the above settlement with the Stipulation of Discontinuance and Settlement Agreement and Release being signed by the claimant; and the Supervisor, Town Attorney and/or Chelus, Herdzik, Speyer & Monte, P.C. be and hereby are authorized to execute and procure all papers necessary to effectuate said settlement and compromise of the above mentioned claim.

RESULT:	ADOPTED [UNANIMOUS]
MOVER:	Mary Holtz, Supervisor
SECONDER:	Gerald Kaminski, Councilmember
AYES:	Holtz, Rogowski, Markel, Kaminski, Wozniak, Benczkowski, Meyers



Town of Cheektowaga

Regular Meeting

~ Minutes ~

3301 Broadway
Cheektowaga, NY 14227
<http://www.town.cheektowaga.ny.us>

Alice Magierski
716-686-3400

Monday, January 6, 2014

6:45 PM

Council Chambers

I. Call to Order

6:45 PM Meeting called to order on January 6, 2014 at Council Chambers, 3301 Broadway St, Cheektowaga, NY.

Attendee Name	Organization	Title	Status	Arrived
Mary Holtz	Town of Cheektowaga	Supervisor	Present	
James P. Rogowski	Town of Cheektowaga	Councilmember	Present	
Charles Markel	Town of Cheektowaga	Councilmember	Present	
Gerald Kaminski	Town of Cheektowaga	Councilmember	Present	
Angela M. Wozniak	Town of Cheektowaga	Councilmember	Present	
Diane Benczkowski	Town of Cheektowaga	Councilmember	Present	
Timothy J. Meyers	Town of Cheektowaga	Councilmember	Present	

2. Additional Attendees

Thomas Adamczak, Supervising Building and Plumbing Inspector
Robert Brandon, Zoning Board Chairman
Brian Krause, Director of Finance and Administration
William Pugh, Town Engineer
Kevin Schenk, Town Attorney
Michael Sliwinski, Captain, Cheektowaga Police Department
Mark Wegner, Highway Superintendent

II. Public Comment Period

III. Resolutions



1. RESOLUTION 2014-2

Transfer of Funds-2013

Sponsored By: Councilmember Kaminski, Supervisor Holtz

BE IT RESOLVED, that the following transfer is hereby approved and made part hereof;

SEWER

FROM:	255.8135.4142	Chemicals	\$1,000.00
-------	---------------	-----------	------------

TO:	255.8135.4164	Gas, Oil & Grease	\$1,000.00
-----	---------------	-------------------	------------

HIGHWAY

FROM:	300.5110.4186	Topsoil	\$11,000.00
-------	---------------	---------	-------------

TO:	300.5110.4162	Gas & Oil	\$11,000.00
-----	---------------	-----------	-------------

RESULT:	ADOPTED [UNANIMOUS]
MOVER:	Gerald Kaminski, Councilmember
SECONDER:	Mary Holtz, Supervisor
AYES:	Holtz, Rogowski, Markel, Kaminski, Wozniak, Benczkowski, Meyers



2. RESOLUTION 2014-3

Warrant

Sponsored By: Supervisor Holtz, Councilmember Kaminski

BE IT RESOLVED, that the following Vouchers & Warrants submitted to the Town of Cheektowaga prior to January 6, 2014 are hereby approved and made part hereof;

GENERAL FUND	\$5,407,381.83
RISK RETENTION FUND	1,964,230.88
NYS HOME PROGRAM	
DEBT	
HUD HOUSING REHABILITATION FUND	
SPECIAL DISTRICTS FUND	1,328,827.40
HIGHWAY FUND	1,081,969.30
CAPITAL FUND	359,903.65
TRUST & AGENCY FUND	14,778.67
HUD CDBG FUND	48,156.29
PART TOWN FUND	252,823.84
NYS AFFORDABLE HOUSING	
	\$10,458,071.86

RESULT:	ADOPTED [UNANIMOUS]
MOVER:	Mary Holtz, Supervisor
SECONDER:	Gerald Kaminski, Councilmember
AYES:	Holtz, Rogowski, Markel, Kaminski, Wozniak, Benczkowski, Meyers



3. RESOLUTION 2014-4

Establishment of Town Board Meeting Dates in 2014

Sponsored By: Supervisor Holtz, Councilmember Rogowski

BE IT RESOLVED, that regular meetings of the Town Board of the Town of Cheektowaga for the calendar year 2014 shall be held at 6:45 P.M. in the Council Chambers of the Town Hall, 3301 Broadway, Cheektowaga, New York on the following referenced dates:

- January 6th, 21st
- February 3rd, 19th
- March 3rd, 17th
- April 7th, 21st
- May 5th, 19th
- June 2nd, 16th
- July 7th, 21st
- August 4th, 18th
- September 2nd, 15th
- October 6th, 20th
- November 3rd, 17th
- December 1st, 15th

and BE IT FURTHER

RESOLVED, that such meetings shall begin with the public comment period at 6:45 P.M. and the meetings proper will begin immediately thereafter, and BE IT FURTHER

RESOLVED, that the Town Clerk be and hereby is directed to forward copies of this resolution to the Cheektowaga Bee, Buffalo News and Metro Source, and BE IT FURTHER

RESOLVED, that the above meeting dates shall be posted on the Town's website.

RESULT:	ADOPTED [UNANIMOUS]
MOVER:	Mary Holtz, Supervisor
SECONDER:	James P. Rogowski, Councilmember
AYES:	Holtz, Rogowski, Markel, Kaminski, Wozniak, Benczkowski, Meyers



4. RESOLUTION 2014-5

Establish Work Session Dates for 2014

Sponsored By: Supervisor Holtz, Councilmember Meyers

BE IT RESOLVED, that the Town Board of the Town of Cheektowaga shall hold work sessions for the calendar year 2014 at 6:00 P.M. on the following dates:

- January 2nd, 14th, 28th
- February 11th, 25th
- March 11th
- April 1st, 15th, 29th
- May 13th, 27th
- June 10th
- July 1st, 15th, 29th
- August 12th, 26th
- September 9th, 30th
- October 14th, 28th
- November 10th, 25th
- December 9th, 30th

, and BE IT FURTHER

RESOLVED, that said work sessions shall be held in the Council Office Conference Room, Town Hall, 3301 Broadway, Cheektowaga, New York, and BE IT FURTHER

RESOLVED, that the Town Clerk be and hereby is directed to forward copies of this resolution to the Cheektowaga Bee, Buffalo News and the Metro Source, and BE IT FURTHER

RESOLVED, that the above Work Session dates shall be posted in the Town's website.

RESULT:	ADOPTED [UNANIMOUS]
MOVER:	Mary Holtz, Supervisor
SECONDER:	Timothy J. Meyers, Councilmember
AYES:	Holtz, Rogowski, Markel, Kaminski, Wozniak, Benczkowski, Meyers



5. RESOLUTION 2014-6

Establish Holidays for 2014

Sponsored By: Supervisor Holtz, Councilmember Markel

BE IT RESOLVED, that the following holidays shall be observed by the Town of Cheektowaga in 2014:

New Year's Day	January 1, 2014	Wednesday
Martin Luther King, Jr. Day	January 20, 2014	Monday
President's Day	February 17, 2014	Monday
Good Friday	April 18, 2014	Friday
Memorial Day	May 26, 2014	Monday
Independence Day	July 4, 2014	Friday
Labor Day	September 1, 2014	Monday
Columbus Day	October 13, 2014	Monday
Election Day	November 4, 2014	Tuesday
Veterans Day	November 11, 2014	Tuesday
Thanksgiving Day	November 27, 2014	Thursday
Day After Thanksgiving	November 28, 2014	Friday
Christmas Eve	December 24, 2014	Wednesday
Christmas Day	December 25, 2014	Thursday

RESULT: ADOPTED [UNANIMOUS]

MOVER: Mary Holtz, Supervisor

SECONDER: Charles Markel, Councilmember

AYES: Holtz, Rogowski, Markel, Kaminski, Wozniak, Benczkowski, Meyers



6. RESOLUTION 2014-7

Designation of Official Newspaper

Sponsored By: Councilmember Rogowski, Councilmember Benczkowski

WHEREAS, Section 64(11) of the Town Law empowers a Town Board to designate a newspaper as the official paper of the Town provided such newspaper is regularly published in the Town and has been entered as second class mail matter, and

WHEREAS, the CHEEKTOWAGA BEE has served as the official newspaper of the Town of Cheektowaga for the past several years, and is qualified to serve as the Town's official newspaper, NOW, THEREFORE, BE IT

RESOLVED, that THE CHEEKTOWAGA BEE be and hereby is designated as the official newspaper of the Town of Cheektowaga.

RESULT:	ADOPTED [UNANIMOUS]
MOVER:	James P. Rogowski, Councilmember
SECONDER:	Diane Benczkowski, Councilmember
AYES:	Holtz, Rogowski, Markel, Kaminski, Wozniak, Benczkowski, Meyers



7. RESOLUTION 2014-8

Designate Depositories for 2014

Sponsored By: Supervisor Holtz, Councilmember Kaminski

BE IT RESOLVED, that the following banking institutions be named official Town Depositories for the Year 2014:

First Niagara Bank (Cheektowaga Office)
Manufacturers and Traders Trust Company (Airport Plaza)
Key Bank (Appletree Business Park and Union Road)
Bank of America (Dick Road Office)
JP Morgan Chase Bank, N.A. (Buffalo Office)
Citizens Bank (Cheektowaga Office)
Evans National Bank

RESULT:	ADOPTED [UNANIMOUS]
MOVER:	Mary Holtz, Supervisor
SECONDER:	Gerald Kaminski, Councilmember
AYES:	Holtz, Rogowski, Markel, Kaminski, Wozniak, Benczkowski, Meyers



8. RESOLUTION 2014-9

Direct Depositories to Accept Supervisor's Facsimile Signature

Sponsored By: Supervisor Holtz, Councilmember Kaminski

BE IT RESOLVED, that First Niagara Bank (Cheektowaga Office), Bank of America (Dick Road Office), Key Bank (Cheektowaga Office), JP Morgan Chase Bank, N.A. (Buffalo Office), Citizens Bank (Cheektowaga Office), Evans National Bank and Manufacturers and Traders Trust Company (Airport Plaza Office), as designated depositories of the Town of Cheektowaga, be and they are hereby requested, authorized and directed to honor checks, notes and other instruments for the payment of moneys against Town funds on deposit therein, including those payable to the individual order of the person whose name appears thereon as signer, when bearing or purporting to bear the facsimile signature of the Supervisor, and BE IT FURTHER

RESOLVED, that First Niagara Bank (Cheektowaga Office), Bank of America (Dick Road Office), Key Bank (Cheektowaga Office), JP Morgan Chase Bank, N.A. (Buffalo Office), Citizens Bank (Cheektowaga Office), Evans National Bank and Manufacturers and Traders Trust Company (Airport Plaza Office) shall be entitled to honor and to charge the proper bank account of the Town of Cheektowaga for such checks, notes and other instruments, regardless of by whom or by what means the actual purported facsimile signature thereon maybe affixed thereto, if such signature resembles the facsimile specimen or specimens, duly certified to or filed with said banks by the Supervisor, the Town Clerk or other officers of the Town of Cheektowaga.

RESULT:	ADOPTED [UNANIMOUS]
MOVER:	Mary Holtz, Supervisor
SECONDER:	Gerald Kaminski, Councilmember
AYES:	Holtz, Rogowski, Markel, Kaminski, Wozniak, Benczkowski, Meyers



9. RESOLUTION 2014-10

Negative SEQR Declaration - 2409 Union Road

Sponsored By: Councilmember Kaminski, Councilmember Markel

WHEREAS, pursuant to the Environmental Impact Review Ordinance of the Town of Cheektowaga, the Environmental Advisory Committee ("EAC") reviews various applications for site plans, rezonings, special permits, etc. and renders its recommendation concerning the environmental significance of such application, AND

WHEREAS, the Town Board, pursuant to the Environmental Impact Review Ordinance of the Town of Cheektowaga, is designated the Lead Agency in most instances, AND

WHEREAS, since the Town Board is the Lead Agency, it must affirm, modify or reject any recommendations submitted to it by the Advisory Committee, AND

WHEREAS, an application was submitted by Lisa M Reinhardt with the permission of the land owner, Mary Jane Boncaldo for the rezoning of 2409 Union Road from NS- Neighborhood Services and RA- Apartment districts to CM- General Commercial for the conversion of an existing medical office into a veterinary hospital, AND

WHEREAS, the Environmental Advisory Committee at its meetings held on December 11, 2013 recommended a determination of non-significance as shown on the attached memorandum dated December 11, 2013, AND

WHEREAS, the Town of Cheektowaga Planning Board recommended approval of the rezoning request at their meeting of October 10, 2013, AND

WHEREAS, this Town Board has reviewed the application submitted and the recommendations made by the Environmental Advisory Committee and the Planning Board NOW, THEREFORE, BE IT

RESOLVED, that this Town Board determines that the project will not have a significant effect on the environment and therefore issues a Negative Declaration for purposes of the State Environmental Quality Review Act (SEQRA).

RESULT:	ADOPTED [UNANIMOUS]
MOVER:	Gerald Kaminski, Councilmember
SECONDER:	Charles Markel, Councilmember
AYES:	Holtz, Rogowski, Markel, Kaminski, Wozniak, Benczkowski, Meyers



10. RESOLUTION 2014-11

Negative SEQR Declaration - 3900 Broadway

Sponsored By: Councilmember Kaminski, Councilmember Markel

WHEREAS, pursuant to the Environmental Impact Review Ordinance of the Town of Cheektowaga, the Environmental Advisory Committee ("EAC") reviews various applications for site plans, rezonings, special permits, etc. And renders its recommendation concerning the environmental significance of such application, AND

WHEREAS, the Town Board, pursuant to the Environmental Impact Review Ordinance of the Town of Cheektowaga, is designated the Lead Agency in most instances, AND

WHEREAS, since the Town Board is the Lead Agency, it must affirm, modify or reject any recommendations submitted to it by the Advisory Committee, AND

WHEREAS, an application was submitted by Column Development, Inc. with the permission of the land owner, Alden State Bank for the rezoning of 3900 Broadway from M1-Light Manufacturing to MS- Motor Service to permit the conversion of an existing warehouse /office facility into a truck rental facility, AND

WHEREAS, the Environmental Advisory Committee at its meetings held on December 11, 2013 recommended a determination of non-significance as shown on the attached memorandum dated December 11, 2013, AND

WHEREAS, the Town of Cheektowaga Planning Board recommended approval of the rezoning and site plan at their meetings of June 13, 2013 and September 12, 2013 respectively, AND

WHEREAS, the Town of Cheektowaga Traffic Safety Commission has reviewed the subject project and is recommending its approval, AND

WHEREAS, this Town Board has reviewed the application submitted and the recommendations made by the Environmental Advisory Committee, the Planning Board and the Traffic Safety Commission NOW, THEREFORE, BE IT

RESOLVED, that this Town Board determines that the project will not have a significant effect on the environment and therefore issues a Negative Declaration for purposes of the State Environmental Quality Review Act (SEQRA).

RESULT:	ADOPTED [UNANIMOUS]
MOVER:	Gerald Kaminski, Councilmember
SECONDER:	Charles Markel, Councilmember
AYES:	Holtz, Rogowski, Markel, Kaminski, Wozniak, Benczkowski, Meyers



11. RESOLUTION 2014-12

Accept Site Plan- 3900 Broadway

Sponsored By: Councilmember Markel, Councilmember Rogowski

WHEREAS, pursuant to the Zoning Law of the Town of Cheektowaga, the Planning Board reviews various development review applications for site plans, rezonings, special permits and realty subdivisions and renders its recommendation concerning the compatibility of such application with the zoning regulations, the Town Master Plan and neighborhood character, AND

WHEREAS, the Town Board, pursuant to section 260-47.1C of the Zoning Law of the Town of Cheektowaga is vested with the authority to approve site plans and modify or reject any recommendation submitted to it by its advisory committees, AND

WHEREAS, Column Development, Inc. With the permission of the land owner, Alden State Bank submitted a development review application for the conversion of an existing warehouse/ office complex into a truck rental facility at 3900 Broadway, AND

WHEREAS, the Town of Cheektowaga Planning Board, reviewed and commented on the Application at their meeting of September 12, 2013 and have recommended approval thereof, AND

WHEREAS, the applicant has agreed to make further modifications to his/her site plan to incorporate a masonry wall gateway feature, and will give the Town of Cheektowaga permission to install a " Welcome to the Town of Cheektowaga "sign on such masonry wall, NOW THEREFORE BE IT,

RESOLVED, that pursuant to Section 260-47-1 of the Code of the Town of Cheektowaga and Section 274-a of New York State Town Law that this Town Board approves the proposed site plan subject to the following conditions:

1. The Town Engineer review and approve the drainage and grading plan.
2. All motor vehicles and rental vehicles shall be stored/displayed in the designated parking spaces as shown on the approved site plan.
3. The applicant provide an operation and maintenance agreement to Erie County Sewer District No.1.(and a copy to the Town Engineer) for the existing private sanitary lateral serving 3914, 3938 and 3940 Ellicott Road and 3900-3926 Broadway

RESULT:	ADOPTED [UNANIMOUS]
MOVER:	Charles Markel, Councilmember
SECONDER:	James P. Rogowski, Councilmember
AYES:	Holtz, Rogowski, Markel, Kaminski, Wozniak, Benczkowski, Meyers



12. RESOLUTION 2014-13

Approval of Rezoning of 3900 Broadway

Sponsored By: Councilmember Markel, Councilmember Meyers

WHEREAS, Sean Hopkins, Esq. petitioned for a rezoning from M1- Light Manufacturing District to MS-Motor Service District for property owned by Column Development, Inc. and located at 3900 Broadway, Cheektowaga, New York, which property is described in the attached legal description, for the conversion of an existing office and accessory warehouse to a truck rental facility, and

WHEREAS, a public hearing on such petition was held before this Town Board on the 18th day of November, 2013 at 6:45 P.M., after publication and service of the notices required by the provisions of the Code of the Town of Cheektowaga ("Zoning Law"), and the Town Law; and all interested parties were given an opportunity to be heard at such hearing, and

WHEREAS, the Cheektowaga Planning Board has reviewed such application and has recommended approval thereof, and

WHEREAS, this Town Board previously issued a Negative Declaration under SEQRA and the Town Environmental Impact Review Ordinance for this rezoning, NOW, THEREFORE, BE IT

RESOLVED, that the application of Sean Hopkins, Esq. for the rezoning from M1-Light Manufacturing District to MS-Motor Service District of the property described in the attached legal description be and the same is hereby approved, and BE IT FURTHER

RESOLVED, that the Zoning Map and Law of the Town Of Cheektowaga be amended in accordance with the above.

LEGAL DESCRIPTION - 3900 BROADWAY

LEGAL DESCRIPTION PARCEL I

ALL THAT TRACT OR PARCEL OF LAND, situate in the Town of Cheektowaga, County of Erie and State of New York, being part of Lot No. 2, Township 11, Range 7 of the Holland Land Company Survey and according to a map filed in the Erie County Clerk's Office under Cover No. 39 is known as part of subdivision Lots 37, 38, 39 and 40, bounded and described as follows: BEGINNING at a point in the northerly line of New Broadway Road a distance of 113.71 feet southwesterly from the intersection of the westerly line of Dick Road (formerly Schoolhouse Road) as now located and the northerly line of New Broadway Road as presently laid out (said present intersection being 67.24 feet further westerly of the previous intersection due to the latest taking by P.S.C. 4094 and described in part of Map 1, Parcel 1), said point of beginning also being the southeast corner of premises heretofore conveyed by the grantor to W. Eugene Franklin, George Donald Franklin and Joan M. Way by deed recorded in the Erie County Clerk's Office in Liber 9465 of Deeds at page 620; thence northerly at an interior angle of 70° 33' 15" and along the easterly line of the aforesaid conveyance a distance of 342.72 feet to the south line of lands conveyed to Angelo M. Fatta and Elmer Gerbracht by deed recorded in the Erie County Clerk's Office in Liber 9415 of Deeds at page 132; thence easterly and along the south

line of the aforesaid Fatta-Gerbracht lands a distance of 80.45 feet to the westerly line of Dick Road as now laid out; thence southerly along the westerly line of Dick Road a distance of 261.49 feet to an iron pipe on the westerly line of the above taking by P.S.C. 4094 as described in Map 1, Parcel 1; thence southwesterly along the southwesterly line of said taking a distance of 67.0 feet to the northerly line of New Broadway Road; thence westerly along the northerly line of New Broadway Road a distance of 113.71 feet to the point and place of beginning.

LEGAL DESCRIPTION PARCEL II

ALL THAT TRACT OR PARCEL OF LAND, situate in the Town of Cheektowaga, County of Erie and State of New York, being part of Lot No. 2, Township 11, Range 7 of the Holland Land Company's Survey and according to a Map filed in the Erie County Clerk's Office under Cover No. 39 is known as part of Subdivision Lot 40, bounded and described as follows:

BEGINNING at a point in the northerly line of New Broadway Road a measured distance of 483.89 feet and a recorded distance of 483.60 feet from the intersection of the northerly line of New Broadway Road with the westerly line of Sublot 34 as shown on said Map, said point of beginning being the southeast corner of lands conveyed to Gaeton Solmaine by Deed recorded in the Erie County Clerk's Office in Liber 3322 of Deeds at page 344; running thence northerly parallel with the westerly line of Sublot 40 and along the easterly line of the lands formerly owned by said Solmaine a measured distance of 301.90 feet; thence easterly at an interior angle of 92° a distance of 0.43 feet; thence northerly at an exterior angle of 90° 20' 40" a distance of 55.01 feet; thence easterly at an interior angle of 92° 01' 02" a distance of 62.08 feet; thence southerly at an interior angle of 85° 20' 10" a distance of 342.72 feet to the northerly line of New Broadway Road, at a point which is 57.79 feet easterly from the place of beginning; thence westerly along the northerly line of New Broadway Road a distance of 57.79 feet to the point and place of beginning.

RESULT:	ADOPTED [UNANIMOUS]
MOVER:	Charles Markel, Councilmember
SECONDER:	Timothy J. Meyers, Councilmember
AYES:	Holtz, Rogowski, Markel, Kaminski, Wozniak, Benczkowski, Meyers



13. RESOLUTION 2014-14

Approve Rezoning of 2409 Union Road

Sponsored By: Councilmember Markel, Councilmember Meyers

WHEREAS, Dr. Lisa M. Reinhardt petitioned for a rezoning from NS- Neighborhood Services District and RA-Apartment District to CM-General Commercial District for a portion of property owned by Mary Jane Boncaldo and located at 2409 Union Road, Cheektowaga, New York, which property is described in the attached legal description, for the conversion of an existing medical office into a veterinary hospital, and

WHEREAS, a public hearing on such petition was held before this Town Board on the 2nd day of December, 2013 at 6:45 P.M., after publication and service of the notices required by the provisions of the Code of the Town of Cheektowaga ("Zoning Law"), and the Town Law; and all interested parties were given an opportunity to be heard at such hearing, and

WHEREAS, the Cheektowaga Planning Board has reviewed such application and has recommended approval thereof, and

WHEREAS, this Town Board previously issued a Negative Declaration under SEQRA and the Town Environmental Impact Review Ordinance for this rezoning, NOW, THEREFORE, BE IT

RESOLVED, that the application of Dr. Lisa M. Reinhardt for the rezoning from NS-Neighborhood Services District and RA-Apartment District to CM-General Commercial District of the property described in the attached legal description be and the same is hereby approved, subject to the following condition:

1. Any future additions to the development or site plan must be resubmitted to the Town Board to determine that the addition is substantially in agreement with the intent of this rezoning
2. The owner of the property, in statements made in a letter dated December 12, 2013, has stated that the property should revert back to its current zoning of NS-Neighborhood Services District and RA-Apartment District in the event that the property is not leased or sold to the Applicant for the practice of veterinary medicine.

, and BE IT FURTHER

RESOLVED, that the Zoning Map and Law of the Town Of Cheektowaga be amended in accordance with the above.

LEGAL DESCRIPTION

ALL THAT TRACT OR PARCEL OF LAND, situate in the Town of Cheektowaga, County of Erie, State of New York, being part of Lot 61, Township 10, Range 7 of the Buffalo Creek Reservation, described as follows:

BEGINNING at the point of intersection of the easterly line of Union Road with the north line of lands conveyed to John Ast by deed recorded in Erie County Clerk's Office in Liber 83 of

Deeds at Page 186; thence easterly along the aforesaid north line of lands of John Ast a distance of 310.00 feet to a point; thence northerly at an interior angle of 90° to a point on the southerly bounds of Slate Bottom Creek; thence westerly along the southerly bounds of Slate Bottom Creek as it winds and bends to a point on the east line of lands appropriated by the People of the State of New York by Notice of Appropriation recorded in the Erie County Clerk's Office in Liber 7130 of Deeds at Page 426; thence southerly on a line drawn parallel to Union Road a distance of 65 feet; thence easterly at an interior angle of 90°, 25 feet to a point on the easterly line of Union Road; thence southerly along the easterly line of Union Road, a distance of 203.2 feet to the point or place of beginning.

RESULT:	ADOPTED [UNANIMOUS]
MOVER:	Charles Markel, Councilmember
SECONDER:	Timothy J. Meyers, Councilmember
AYES:	Holtz, Rogowski, Markel, Kaminski, Wozniak, Benczkowski, Meyers



14. RESOLUTION 2014-15

Award of Bid for Demolition of 1182-1192 Walden Avenue (BID No. 2013-36 LAW)

Sponsored By: Councilmember Markel, Supervisor Holtz

WHEREAS, a Notice to Bidders was advertised for the Demolition and Asbestos Abatement of structures at 1182-1192 Walden Avenue (BID 2013-36 LAW); and

WHEREAS, subsequent to the publication of said Notice to Bidders, the structure at 1182 Walden Avenue was declared a nuisance and hazard by the Supervising Code Enforcement Officer, who recommended that the demolition of said structure should proceed as a controlled demolition, and an appropriate addendum was issued; and

WHEREAS, bid proposals were received and opened on December 27, 2013 for said controlled demolition of 1182 Walden Avenue and the demolition of 1192 Walden Avenue; and

WHEREAS, the proposals were reviewed by the Town Attorney and, based on proposals submitted, the Town Attorney has recommended that this Town Board award the bid for the controlled demolition of the structure located at 1182 Walden Avenue and the demolition of the structure at 1192 Walden Avenue to Empire Dismantlement Corp., NOW, THEREFORE, BE IT

RESOLVED, that this Town Board hereby awards the bid for the controlled demolition of 1182 Walden Avenue and the demolition of 1192 Walden Avenue to:

Empire Dismantlement Corp.
2680 Grand Island Boulevard
Grand Island, NY 14072

for the bid price of \$38,000.00, being the lowest responsible bid meeting specifications, and BE IT FURTHER

RESOLVED, that the Supervisor be and hereby is directed to execute an agreement with Empire Dismantlement Corp. for the aforesaid services, and BE IT FURTHER

RESOLVED, that moneys for said services shall be appropriated from budget line item number 0800-800-0440.

RESULT:	ADOPTED [UNANIMOUS]
MOVER:	Charles Markel, Councilmember
SECONDER:	Mary Holtz, Supervisor
AYES:	Holtz, Rogowski, Markel, Kaminski, Wozniak, Benczkowski, Meyers



15. RESOLUTION 2014-16

Readopt Investment Policy

Sponsored By: Supervisor Holtz, Councilmember Kaminski

WHEREAS, by resolution dated May 3, 1993, the Cheektowaga Town Board adopted an Investment Policy as the comprehensive investment policy of the Town of Cheektowaga, and

WHEREAS, by subsequent resolutions, the Cheektowaga Town Board adopted amendments to such Investment Policy, and

WHEREAS, periodically, this Town Board must readopt and reaffirm such Investment Policy as the Investment Policy of the Town of Cheektowaga, NOW, THEREFORE, BE IT

RESOLVED, that this Town Board hereby adopts the attached Investment Policy as the comprehensive investment policy of the Town of Cheektowaga, effective immediately.

TOWN OF CHEEKTOWAGA

INVESTMENT POLICY

I. SCOPE

This investment policy applies to all moneys and other financial resources available for investment on behalf of the Town of Cheektowaga or on behalf of any other entity or individual.

II. OBJECTIVES

The primary objectives of the Town of Cheektowaga investment activities are to conform with all applicable federal, state, and other legal requirements; to adequately safeguard principal; to provide sufficient liquidity to meet all operating requirements; and to obtain a reasonable rate of return.

III. DELEGATION OF AUTHORITY

The Town Board's responsibility for administration of the investment program is delegated to the Chief Fiscal Officer (Supervisor), and Director of Administration & Finance who shall establish written procedures for the operation of the investment program consistent with these investment guidelines. Such procedures shall include an adequate internal control structure to provide a satisfactory level of accountability based on a data base or records incorporating description and amount of investments, transaction dates, and other relevant information and regulate the activities of subordinate employees.

IV. PRUDENCE

All participants in the investment process shall seek to act responsibly as custodians of the public trust and shall avoid any transaction that might impair public confidence

in the Town of Cheektowaga to govern effectively.

Investments shall be made with judgment and care, under circumstances then prevailing, which persons of prudent discretion and intelligence exercise in the management of their own affairs, not for speculation, but for investment, considering the safety of the principal as well as the probable income to be derived.

All participants involved in the investment process shall refrain from personal business activity that could conflict with proper execution of the investment program, or which could impair their ability to make impartial investment decisions.

V. DIVERSIFICATION

It is the policy of the Town of Cheektowaga to diversify its deposits and investments by financial institution, by investment instrument, and by maturity scheduling if this proves to be advantageous to the Town.

VI. INTERNAL CONTROLS

It is the policy of the Town of Cheektowaga for all moneys collected by any officer or employee of the Town of Cheektowaga to transfer those funds to the Supervisor and/or Director of Administration & Finance within 3 days of deposit, or within the time period specified in law, whichever is shorter.

The Supervisor, Director of Administration & Finance, or other officer having custody of money is responsible for establishing and maintaining an internal control structure to provide reasonable, but not absolute, assurance that deposits and investments are safeguarded against loss from unauthorized use or disposition, that transactions are executed in accordance with management's authorization and recorded properly, and are managed in compliance with applicable laws and regulations.

VII. DESIGNATION OF DEPOSITORIES

The banks and trust companies authorized for the deposit of monies up to the maximum amount are designated in Appendix A to the policy.

VIII. COLLATERALIZING OF DEPOSITS

In accordance with the provisions of General Municipal Law, Sec. 10, all deposits of the Town of Cheektowaga, including certificates of deposits, and special time deposits, in excess of the amount insured under the provisions of the Federal Deposit Insurance Act shall be secured:

1. By a pledge of "eligible securities" with an aggregate "market value" as provided by GML Sec. 10, equal to the aggregate amount of deposits from the categories designated in Appendix B to the policy.
2. By an eligible "letter of credit" issued by a qualified bank other than the bank with the deposits in favor of the Town of Cheektowaga for a time not to exceed 90 days with an aggregate value equal to the 140% of the

aggregate amount of deposits and the agreed upon interest, if any. A qualified bank is one whose commercial paper and other unsecured short-term debt obligations are rated in one of the three highest recognized statistical rating organizations or by a bank that is in compliance with applicable federal minimum risk-based capital requirements.

3. By an eligible surety bond payable to the Town of Cheektowaga for an amount at least equal to 100% of the aggregate amount of deposits and the agreed upon interest, if any, executed by an insurance company authorized to do business in New York State, whose claims-paying ability is rated in the highest rating category by at least two nationally recognized statistical rating organizations.

IX. SAFEKEEPING AND COLLATERALIZATION

Eligible securities used for collateralizing deposits shall be held by the depository and/or a third party bank or trust company subject to security and custodial agreements.

The security agreement shall provide that eligible securities are being pledged to secure the Town of Cheektowaga deposits together with agreed upon interest, if any, and any costs or expenses arising out of the collection of such deposits upon default. It shall also provide the conditions under which the securities may be sold, presented for payment, substituted or released and the events which will enable the Town of Cheektowaga to exercise its rights against the pledged securities. In the event that the securities are not registered on inscribed in the manner of the Town of Cheektowaga, such securities shall be delivered in a form suitable for transfer or with an assignment in blank to the Town of Cheektowaga or its custodial bank.

The custodial agreement shall provide that securities held by the bank or trust company, or agent of and custodian for the Town of Cheektowaga, will be

kept separate and apart from the general assets of the custodial bank or trust company and will not, in any circumstances, be commingled with or become part of the backing for any other deposit or other liabilities. The agreement should also describe that the custodian shall confirm to receipt, substitution or release of the securities. The agreement shall provide for the frequency of revaluation of eligible securities and for the substitution of securities when a change in the rating of a security may cause ineligibility. Such agreement shall include all provisions necessary to provide the Town of Cheektowaga a perfected interest in the securities.

X. PERMITTED INVESTMENTS

As authorized by General Municipal Law, Sec. 11, the Town of Cheektowaga authorizes the Chief Fiscal Officer, Director of Administration & Finance, or other officer having custody of money to invest moneys not required for immediate expenditure for terms not to exceed 185 days or its projected cash flow needs in the following types of investments:

. Special Time Deposit accounts;

- . Certificate of Deposits;
- . Obligations of the United States of America;
 - . Obligations issued pursuant to LFL Sec. 24.00 of 25.00 (with approval of the State Comptroller) by any municipality, school district or district corporation other than the Town of Cheektowaga;
 - . Obligations of public housing authorities, urban renewal agencies and industrial development agencies where general State statutes governing such entities or whose specific enabling legislation authorizes such investment;
 - . Certificates of Participations (COPS) issued pursuant to GML Sec. 109-b;
 - . Obligations of this local government, but only with any moneys in a reserve fund established pursuant to GML Sec(s) 6-c, 6-d, 6-e, 6-g, 6-h, 6-j, 6-k, 6-l, 6-m, or 6-n.

All investment obligations shall be payable or redeemable at the option of the Town of Cheektowaga within such times as the proceeds will be needed to meet expenditures for purposes for which the moneys were provided and, in the case of obligations purchased with the proceeds of bonds, or notes, shall be payable or redeemable at the option of the Town of Cheektowaga within two years of the date of purchase.

XI. AUTHORIZED FINANCIAL INSTITUTIONS AND DEALERS

The Town of Cheektowaga shall maintain a list of financial institutions and dealers approved for investment purposes and establish appropriate limits to the amount of investments which can be made with each financial institution of dealer. All financial institutions with which the Town of Cheektowaga conducts business must be credit worthy. Banks shall provide their most recent Consolidated Report of Condition (Call Report) at the request of the

Town of Cheektowaga. Security dealers not affiliated with a bank shall be required to be classified as reporting dealers affiliated with the New York Federal Reserve Bank, as primary dealers. The Chief Fiscal Officer and/or the Director of Administration & Finance is responsible for evaluating the financial position and maintaining a listing of proposed depositories, trading partners and custodians. Such listing shall be evaluated at least annually.

XII. PURCHASE OF INVESTMENTS

The Chief Fiscal Officer and/or the Director of Administration & Finance, or other officer having custody of money is authorized to contract for the purchase of investments:

1. Directly, including through a repurchase agreement, from an authorized trading partner.
2. By participation in a cooperative investment program with another authorized entity pursuant to Article 5G of the General Municipal Law where such program meets all the requirements set forth in the Office of the State Comptroller Opinion No. 88-46, and the specific program has been authorized by the governing board.

3. By utilizing an ongoing investment program with an authorized trading partner pursuant to a contract authorized by the Town Board.

All purchased obligations, unless registered or inscribed in the name of the Town, shall be purchased through, delivered to and held in the custody of a bank or trust company. Such obligations shall be purchased, sold or presented for redemption or payment by such bank or trust company only in accordance with prior written authorization from the officer authorized to make the investment. All such transactions shall be confirmed in writing to the Town of Cheektowaga by the bank or trust company. Any obligation held in the custody of a bank or trust company shall be held pursuant to a written custodial agreement as described in General Municipal Law, Sec. 10.

The custodial agreement shall provide that securities held by the bank or trust company, as agent of and custodian for the Town of Cheektowaga, will be kept separate and apart from the general assets of the custodial bank or trust company and will not, in any circumstances, be commingled with or become part of the backing for any other deposit or other liabilities. The agreement shall describe how the custodian shall confirm the receipt and release of the securities. Such agreement shall include all provisions necessary to provide the Town of Cheektowaga a perfected interest in the securities.

XIII. REPURCHASE AGREEMENTS

Repurchase agreements are authorized subject to the following restrictions:

- . All repurchase agreements must be entered into subject to a Master Repurchase Agreement.
- . Trading partners are limited to banks or trust companies authorized to do business in New York State and primary reporting dealers.
- . Obligations shall be limited to obligations of the United States of America and obligations guaranteed by agencies of the United States of America.
- . No substitution of securities will be allowed.
- . The custodian shall be a party other than the trading partner.

Appendix A

BANK	TYPE	ACCOUNT NUMBER	MAXIMUM AMOUNT	TOWN OFFICER
Bank of America	Joint Bail	XXX1314	200,000	Justice
Bank of America	Parking	XXX4164	75,000	Justice
Bank of America	Small claims	XXX2363	25,000	Justice
Bank of America	Town Fees	XXX5658	200,000	Justice
Bank of America	Town Fees	XXX2451	200,000	Justice
Chase	Block Grant	XXXXX3141		Dir. Of Admin & Finance
Chase	Consolidated Savings	XXXXX4217	80,000,000	Dir. Of Admin & Finance
Chase	Controlled Disbursement account (Zero balance Account)	XXXXX5888	-	Dir. Of Admin & Finance
Chase	First Niagara Risk Management	XXXXX3827	200,000	Dir. Of Admin & Finance
Chase	JAG Grant	XXXXX7385		Dir. Of Admin & Finance
Chase	Municipal Clearing Checking	XXX5589	3,000,000	Dir. Of Admin & Finance
Chase	NYS Home Program	XXXXX9969		Dir. Of Admin & Finance
Chase	Payroll Checking	XXXXXX3914	\$2,000,000	Dir. Of Admin & Finance
Chase	School Tax	XXXXX0376		Town Clerk
M&T Bank	School Tax	XXXXXX4406		Town Clerk
Chase	Tax Collection Savings Account	XXXXX0422		Town Clerk
Chase	Tax Receiver	XXXXX0368		Town Clerk
Chase	Town Clerk	XXXXX0384		Town Clerk
M&T Bank	Town & County Taxes	XXXXXX4414		Town Clerk
M&T Bank	Municipal Money Market Tax Savings	XXXXXXXXXX6489		Town Clerk
Chase	Trust & Agency - Asset Forfeiture	XXXXX9955	500,000	Dir. Of Admin & Finance
Chase	Trust & Agency - Checking	XXXXX9890	7,000,000	Dir. Of Admin & Finance
Chase	Trust & Agency - DARE	XXXXX9963	50,000	Dir. Of Admin & Finance
Chase	Trust & Agency - Library	XXX6144	800,000	Dir. Of Admin & Finance
Chase	Trust & Agency - Pyramid	XXXXX9939	500,000	Dir. Of Admin & Finance
Chase	Trust & Agency - Sewer Drainage	XXXXX9971		Dir. Of Admin & Finance

Chase	Cheektowaga Youth & Rec Services	xxxxx8285	500,000	Finance Dir. Of Admin & Finance
Chase	NSP Grant	xxxxx6170		Dir. Of Admin & Finance
M&T bank	Investments	xxxxxx2207		Dir. Of Admin & Finance
Citizens	General fund checking	xxxxxx0824		Dir. Of Admin & Finance
M&T bank	Risk Retention fund	xxxxxx0836		Dir. Of Admin & Finance
Chase	HUD Rehab Loan Program	XXXXX2675		Dir. Of Admin & Finance
First Niagara	Money Market Account	XXXXX0455		Dir. Of Admin & Finance
chase	NYS Affordable Housing	XXXXXX5032		Dir. Of Admin & Finance
M&T bank	General - Checking	xxx7346		Dir. Of Admin & Finance
M&T bank	General - Savings	xxxxxx7271	6,000,000	Finance
MBIA-Class	Debt Reserve Fund	NY-xx-xx73-0001	6,000,000	Finance
MBIA-Class	General Fund	NY-xx-xx73-0003	2,000,000	Finance
MBIA-Class	Risk Retention Fund	NY-xx-xx73-0002	2,000,000	Finance
MBIA-Class	Special Districts Fund	NY-xx-xx73-0004	1,000,000	Finance
			3,000,000	Finance

APPENDIX B

Schedule of Eligible Securities

- (i) Obligations issued or fully insured or guaranteed as to the payment of principal and interest, by the United States of America, an agency thereof or a United States government sponsored corporation.
- (ii) Obligations issued or fully guaranteed by the International Bank for Reconstruction and Development, Inter-American Development Bank, the Asian Development Bank and the African Development Bank.
- (iii) Obligations partially insured or guaranteed by any agency of the United States of America, at a proportion of the Market Value of the obligation that represents the amount of the insurance or guaranty.
- (iv) Obligations issued or fully guaranteed by the State of New York, obligations issued by a municipal corporation, school district or district corporation of such State of obligations of any public benefit corporation which under a specific State statute may be accepted as security for deposit of public moneys.
- (v) Obligations issued by states (other than the State of New York) of the United States rated in one of the three highest rating categories by at least one nationally recognized statistical rating organization.
- (vi) Obligations of Puerto Rico rated in one of the three highest rating categories by at least one nationally recognized statistical rating organization.
- (vii) Obligations of counties, cities and other governmental entities of a state other than the State of New York having the power to levy taxes that are backed by the full faith and credit of such governmental entity and rated in one of the three highest rating categories by at least one nationally recognized statistical rating organization.

APPENDIX B

Page 2

- (viii) Obligations of domestic corporations rated in one of the two highest rating categories by at least one nationally recognized statistical rating organization.
- (ix) Any mortgage related securities, as defined in the Securities Exchange Act of 1934, as amended, which may be purchased by banks under the limitations established by the bank regulatory agencies.
- (x) Commercial paper and banker's acceptances issued by a bank, other than the Bank, rated in the highest short term category by at least one nationally recognized statistical rating organization and having maturities of not longer than 60 days from the date they are pledged.
- (xi) Zero coupon obligations of the United States government marketed as

“Treasure Strips”.

RESULT:	ADOPTED [UNANIMOUS]
MOVER:	Mary Holtz, Supervisor
SECONDER:	Gerald Kaminski, Councilmember
AYES:	Holtz, Rogowski, Markel, Kaminski, Wozniak, Benczkowski, Meyers



16. RESOLUTION 2014-17

Call for Public Hearing to Amend Traffic Ordinance

Sponsored By: Councilmember Markel, Councilmember Rogowski

BE IT RESOLVED, that a public hearing on proposed amendments to Chapter 235 (formerly Chapter 76) of the Code of the Town of Cheektowaga (Vehicle and Traffic) be held on January 21, 2014 at 6:45 P.M. at the Town Hall, 3301 Broadway, Cheektowaga, New York for the purpose of considering the advisability of adopting said amendments, and the Town Clerk is hereby directed to publish the following Notice of Hearing in the CHEEKTOWAGA BEE, said amendments being set forth in said Notice of Hearing.



NOTICE OF PUBLIC HEARING

PLEASE TAKE NOTICE that the Town Board of the Town of Cheektowaga, Erie County, New York will hold a public hearing at the Town Hall, 3301 Broadway in said Town of Cheektowaga on January 21, 2014 at 6:45 P.M. to consider the advisability of adopting amendments to Chapter 235 of the Code of the Town of Cheektowaga (Vehicle and Traffic); said proposed amendments being as follows:

ARTICLE V. Schedules, Section 235-49, Schedule X: Parking Prohibited in Designated Locations, shall be amended by deleting therefrom the following:

In accordance with the provisions of §235-34, no person shall park a vehicle at any time upon any of the following described streets or parts of streets:

SOUTH CREEK DRIVE - North side: from east curb line of Union Road to west curb line of Nagel Drive

ARTICLE V. Schedules, Section 235-49, Schedule X: Parking Prohibited in Designated Locations, shall be amended by adding thereto the following:

In accordance with the provisions of § 235-34, no person shall park a vehicle at any time upon any of the following described streets or parts of streets:

MARYVALE DRIVE - North side: from the west curb line of Cayuga Road to a point 255 feet west.

TOWN HALL DRIVEWAY IN FRONT OF TOWN HALL - North side: from the east curb line of the Broadway Access Road easterly to the west curb line of the driveway from Broadway

CONSTANCE LANE - East side: from the south curb line of Fairelm Lane to a point 50 feet south.

ARTICLE V. Schedules, Section 235-51, Schedule XII: Stopping Prohibited in Designated

Locations, shall be amended by deleting therefrom the following:

DUKE ROAD - West side (north-south leg): from the south curb line of Walden Avenue to the north curb line of Duke Road (east-west leg)

ARTICLE V. Schedules, Section 235-55, Schedule XVI: No Parking Certain Hours, shall be amended to add the following:

TOWN HALL DRIVEWAY IN FRONT OF TOWN HALL - South side: from the east curb line of the Broadway Access Road to the west curb line of the driveway from Broadway - Fifteen (15) minutes only.

ARTICLE V. Schedules, Section 235-46, Schedule VII, Stop Intersections, shall be amended by adding thereto the following:

Stop Signs on	Direction Traffic Stops	At Intersection of
Felber Lane	East	Keicher Road
Burdette Drive	Southwest	Huth Road

BY ORDER OF THE TOWN BOARD OF THE TOWN OF CHEEKTOWAGA, ERIE COUNTY, NEW YORK.

Dated: January 6, 2014

ALICE MAGIERSKI, Town Clerk

RESULT:	ADOPTED [UNANIMOUS]
MOVER:	Charles Markel, Councilmember
SECONDER:	James P. Rogowski, Councilmember
AYES:	Holtz, Rogowski, Markel, Kaminski, Wozniak, Benczkowski, Meyers



17. RESOLUTION 2014-18

Call for Public Hearing for 2014 Community Development Block Grant Program

Sponsored By: Councilmember Markel, Supervisor Holtz

WHEREAS, the Town is eligible to receive approximately \$836,000 in Community Development Block Grant funds and approximately \$200,000 in Home Investment Partnership program funds for the 2014 Program Year, and

WHEREAS, the Town is required to hold public hearings to obtain the views of Town residents, public agencies and other interested parties on housing and community development needs in the Town, and

WHEREAS, activities proposed for funding with Program Year 2014 Community Development Block Grant and HOME Program funds have been made available for public review in the public libraries within the Town, the Cheektowaga Town Clerk's Office and the Community Development Office, NOW, THEREFORE, BE IT

RESOLVED, that a public hearing be held on January 21, 2014 at 6:45 P.M. at Cheektowaga Town Hall, 3301 Broadway, Cheektowaga, New York 14227 for the above stated purpose, and BE IT

FURTHER RESOLVED, that the attached public notice of such public hearing be published in the Cheektowaga Bee on Thursday, January 9, 2014.



Notice of Public Hearing
Town of Cheektowaga FY 2014 Annual Plan
Community Development Block Grant and HOME Programs

A public hearing will be held on Tuesday, January 21, 2014 at 6:45 P.M. at Cheektowaga Town Hall, 3301 Broadway, Cheektowaga, NY 14227 on the Town's Fiscal Year 2014 Annual Plan for the Community Development Block Grant (CDBG) and HOME Investment Partnership Act (HOME) Programs to obtain the views of citizens and interested parties on housing and community development needs in the Town and on the draft Action Plan which has been made available for public review in Town Hall, the Community Development Office and Cheektowaga Branch Libraries. The Annual Plan outlines housing and community development projects proposed to be funded with FY 2014 CDBG and HOME Program funds. The Town is eligible to receive approximately \$836,000 in CDBG funds and approximately \$200,000 in HOME Investment Partnership Program funds from HUD in 2014. The Town estimates approximately \$210,000 in program income from its revolving housing rehabilitation loan program and \$300,000 in economic development revolving business loan program income will be received. Those wishing to offer comments at the hearing are asked to also submit a written text, which may also be submitted to the Cheektowaga Community Development Office, 275 Alexander Avenue, Cheektowaga, New York, 14211. Interpreters will be made available at the meetings

upon prior request to sign for the hearing impaired. If you need such special arrangements, contact the Cheektowaga Community Development Office at 897-7200, Ext. 7, at least seven (7) business days prior to the hearing. The hearing location is accessible to the physically disabled.

RESULT:	ADOPTED [UNANIMOUS]
MOVER:	Charles Markel, Councilmember
SECONDER:	Mary Holtz, Supervisor
AYES:	Holtz, Rogowski, Markel, Kaminski, Wozniak, Benczkowski, Meyers



18. RESOLUTION 2014-19

Notice to Bidders - Clothing (#2014-1) Parks/Rec. Programs

Sponsored By: Councilmember Wozniak, Councilmember Rogowski

WHEREAS it is in order that bids be advertised for the purchase of clothing and uniforms (Bid # 2014-1) for the Town of Cheektowaga Department of Youth and Recreational Services, BE IT

RESOLVED that the Town Clerk be directed to publish a Notice to Bidders, to be published in the CHEEKTOWAGA BEE, for the furnishing of said clothing and uniforms. Information for bidders and specifications may be obtained from the office of Alice Magierski, Town Clerk, and BE IT FURTHER

RESOLVED that sealed bids (Bid # 2014-1) will be received on January 22, 2014 at 11:00 a.m. Eastern Standard Time at a public bid opening to be held in the Town Clerk's Office located in Cheektowaga Town Hall.



NOTICE TO BIDDERS

Sealed proposals will be received and considered by the Town Board of the Town of Cheektowaga on January 22, 2014 at 11:00 a.m. Eastern Standard Time at Town Hall, corner of Broadway and Union Road for the purchase of clothing for use in various Parks, Recreation & Youth Services programs.

Information for bidders and specifications may be obtained from the Town Clerk at her office in Town Hall.

Bid prices will be in effect for the calendar years 2014, 2015, and 2016.

The Town of Cheektowaga reserves the right to consider informal any bid not prepared and submitted in accordance with the provisions of the specifications and may waive any informalities, make an award to other than the lower bidder, should it be in the best interest of the Town, or reject any or all bids.

By order of the Town of Cheektowaga, Erie County, New York.

Alice Magierski, Town Clerk

RESULT: **ADOPTED [UNANIMOUS]**
MOVER: Angela M. Wozniak, Councilmember
SECONDER: James P. Rogowski, Councilmember
AYES: Holtz, Rogowski, Markel, Kaminski, Wozniak, Benczkowski, Meyers



19. RESOLUTION 2014-20

Notice to Bidders Baseball & Softball Equipment #2014-2

Sponsored By: Councilmember Wozniak, Councilmember Rogowski

WHEREAS it is in order that bids be advertised for the purchase of baseball and softball equipment (Bid # 2014-2) for the Town of Cheektowaga Department of Youth and Recreational Services, BE IT

RESOLVED that the Town Clerk be directed to publish a Notice to Bidders, to be published in the CHEEKTOWAGA BEE, for the furnishing of said equipment. Information for bidders and specifications may be obtained from the office of Alice Magierski, Town Clerk, and BE IT FURTHER

RESOLVED that sealed bids (Bid #2014-2) will be received on January 22, 2014 at 11:00 a.m. Eastern Standard Time at a public bid opening to be held in the Town Clerk's Office located in Cheektowaga Town Hall.



NOTICE TO BIDDERS

Sealed bid proposals will be received and considered by the Town Board of the Town of Cheektowaga, publicly opened and read by the Town Clerk of the Town of Cheektowaga, Erie County, New York, on January 22, 2014 at 11:00 a.m. Eastern Standard Time at Town Hall, corner of Broadway and Union Road for the purchase of baseball and softball equipment. (Bid 2014-2).

Information for bidders and specifications may be obtained from the Town Clerk at her office located in the Cheektowaga Town Hall. One bid is to be submitted for the purchase of Baseball and Softball Equipment (or equivalents) as listed in the bid specifications.

The Town Board reserves the right to consider informal any bid not prepared and submitted in accordance with the provisions of the specifications and contract documents, and may waive any informalities, make an award to other than the low bidder should it be in the best interest of the Town, or reject any or all bids.

By order of the Town Board of the Town of Cheektowaga, Erie County, New York.

Alice Magierski, Town Clerk

RESULT:	ADOPTED [UNANIMOUS]
MOVER:	Angela M. Wozniak, Councilmember
SECONDER:	James P. Rogowski, Councilmember
AYES:	Holtz, Rogowski, Markel, Kaminski, Wozniak, Benczkowski, Meyers



20. RESOLUTION 2014-21

Notice to Bidders For Asbestos Survey for Property Located At 191 Evergreen Place (BID 2014-03 LAW)

Sponsored By: Councilmember Markel, Supervisor Holtz

WHEREAS, pursuant to the Town's Unsafe Buildings Law, Nussbaumer & Clarke, Inc., a duly authorized agent of the Town of Cheektowaga, has issued a written report stating that the building located at 191 Evergreen Place is unsafe and recommended that such building be demolished; and

WHEREAS, the owners and/or lienholders of said property were notified to demolish the building on said property, and no action for demolition has been taken to date; and

WHEREAS, a hearing was held in front of this Board on December 16, 2013 concerning said unsafe building and the requested demolition; and

WHEREAS, the Town of Cheektowaga needs to take action to demolish the building located on said property in the event the owner of same does not do so; and

WHEREAS, prior to demolition of said property, the Town needs to have an asbestos survey done to determine whether there is asbestos in said building; and

WHEREAS, a Notice to Bidders has been prepared for this matter; NOW, THEREFORE, BE IT

RESOLVED, that this Town Board hereby approves the Notice to Bidders for the Asbestos Survey for property located at 191 Evergreen Place in the Town of Cheektowaga (Bid 2014-03 LAW); and BE IT FURTHER

RESOLVED, that the Town Clerk's Office be and hereby is directed to publish the attached Notice to Bidders in the CHEEKTOWAGA BEE; and BE IT FURTHER

RESOLVED, that bids for the Asbestos Survey, Specifications and Air Monitoring Services for 191 Evergreen Place shall be due no later than Wednesday, January 15, 2014, at 11:00 A.M. at the Town Clerk's Office, and BE IT FURTHER

RESOLVED, that the Town Clerk be and hereby is appointed as the officer to open said bids in the Council Chambers of Town Hall on Wednesday, January 15, 2014 at 11:00 a.m.



NOTICE TO BIDDERS

Sealed proposals will be received by the Town of Cheektowaga on Wednesday, January 15, 2014 at 11:00 A.M. at the Town Hall, 3301 Broadway, Cheektowaga, New York, for asbestos surveys, asbestos specifications preparation, and air monitoring services for residential property located at 191 Evergreen Place, Cheektowaga, New York (BID 2014-03

LAW).

Information for bidders and specifications may be obtained from the Town Clerk at her office in said Town.

The Town Board reserves the right to consider informal any bid not prepared and submitted in accordance with the provisions of the specification and contract documents, and may waive any informalities, make an award to other than the low bidder, or reject any or all bids should it be in the best interest of the Town.

BY ORDER OF THE TOWN BOARD OF THE TOWN OF CHEEKTOWAGA, ERIE COUNTY, NEW YORK.

Alice Magierski
Town Clerk

Dated: 6 January 2014

RESULT:	ADOPTED [UNANIMOUS]
MOVER:	Charles Markel, Councilmember
SECONDER:	Mary Holtz, Supervisor
AYES:	Holtz, Rogowski, Markel, Kaminski, Wozniak, Benczkowski, Meyers



21. RESOLUTION 2014-22

Request for Proposals for Demolition of 1007 Walden

Sponsored By: Councilmember Markel, Supervisor Holtz

WHEREAS, the Town has been awarded funds from the U.S. Department of Housing and Urban Development for neighborhood improvements in the Town of Cheektowaga, and

WHEREAS, the Town of Cheektowaga's Department of Community and Economic Development has identified the need for the demolition of 1007 Walden Avenue to complement prior improvements on this street, and

WHEREAS, plans and specifications have been prepared for asbestos abatement and demolition of said properties, NOW THEREFORE BE IT

RESOLVED, that the Town Clerk is hereby directed to publish a Notice of Request for Proposals for the furnishing of equipment, operators and laborers for asbestos abatement and demolition of 1007 Walden Avenue, said notice to be published in the CHEEKTOWAGA BEE, the BUFFALO NEWS and the BUFFALO CRITERION; and BE IT FURTHER

RESOLVED, that sealed proposals will be received by the Town Clerk of the Town of Cheektowaga on the 29th day of January, 2014, at 11 A.M. at her office in said Town Hall.

Requests for Proposals may be obtained from the Department of Community Development at 275 Alexander Avenue, Cheektowaga, NY or by request at (716) 897-7200, extension 3, or on line at tocny.org, Department of Community Development, Document Center.

Three copies of the proposal shall be submitted in a sealed envelope plainly marked on the outside "Proposal for the Removal of Asbestos and Demolition of 1007 Walden Avenue" and submitted to the Town Clerk prior to bid opening.

No bidder may withdraw his proposal within forty-five (45) days after the actual date of the opening thereof.

The Town Board reserves the right to consider informal any proposal not prepared and submitted in accordance with the provisions of the specifications and contract documents, and may waive any informalities, make an award to any company it determines to be in the best interest of the Town, or reject any or all bids.

BY ORDER OF THE TOWN BOARD OF THE TOWN OF CHEEKTOWAGA, ERIE COUNTY, NEW YORK.

ALICE MAGIERSKI, Town Clerk
DATED: January 6, 2014



NOTICE OF REQUEST FOR PROPOSALS

Sealed proposals will be received and considered by the Town Board of the Town of Cheektowaga on Wednesday, January 29, 2014 at 11:00 A.M. at the Office of the Town Clerk at Town Hall, corner of Broadway and Union Roads, for the furnishing of labor, tools, equipment, materials and incidentals required for asbestos abatement and demolition of 1007 Walden Avenue, Cheektowaga, New York 14211.

Bidders of this work will be required to comply with federal requirements, including the President's Executive Order number 11246. The requirements for bidders and contractors under this order which concerns non-discrimination in employment and are explained in the specifications.

Information and contract specifications may be obtained from Requests for Proposals may be obtained from the Department of Community Development at 275 Alexander Avenue, Cheektowaga, NY; by request at (716) 897-7200, extension 3, or on line at tocny.org, Department of Community Development, Document Center.

Three copies of the proposal shall be submitted in a sealed envelope plainly marked on the outside "Proposal for the Removal of Asbestos and Demolition of 1007 Walden Avenue" and submitted to the Town Clerk prior to bid opening.

No bidder may withdraw his proposal within forty-five (45) days after the actual date of the opening thereof.

The Town Board reserves the right to consider informal any proposal not prepared and submitted in accordance with the provisions of the specifications and contract documents, and may waive any informalities, make an award to any company it determines to be in the best interest of the Town, or reject any and all bids.

The right to reject any and all bids, or to make an award other than the low bidder, should it be deemed to be in the best interest of the Town of Cheektowaga, and in accordance with the law, is herewith reserved. Attention of the bidders is further called to Section 103-d of the General Municipal Law which requires a bidder's Certificate of Non-Collusion. Such certificate is part of the bid or proposal form and, unless complied with, such bid will not be accepted.

BY ORDER OF THE TOWN BOARD OF THE TOWN OF CHEEKTOWAGA, ERIE COUNTY,
NEW YORK.

ALICE MAGIERSKI, Town Clerk
DATED: January 6, 2014

RESULT:	ADOPTED [UNANIMOUS]
MOVER:	Charles Markel, Councilmember
SECONDER:	Mary Holtz, Supervisor
AYES:	Holtz, Rogowski, Markel, Kaminski, Wozniak, Benczkowski, Meyers



22. RESOLUTION 2014-23

Issue Request for Proposals for Grant Consultant

Sponsored By: Supervisor Holtz, Councilmember Kaminski

WHEREAS, the Town's Agreement for grant development, writing and administration services to the Town expired on December 31, 2013, and this Town Board must issue a Request for Proposals for a new agreement, NOW, THEREFORE, BE IT

RESOLVED, that the Town Clerk is hereby directed to publish a Notice of Request for Proposals for Grant Funding Consultant Services to the Town of Cheektowaga for 2014, said notice to be published in the CHEEKTOWAGA BEE; and BE IT FURTHER

RESOLVED, that sealed proposals will be received on the 29th day of January, 2014 11:00 A.M., at a public opening to be held in the Council Chambers in the Cheektowaga Town Hall.



NOTICE OF REQUEST FOR PROPOSALS

Sealed proposals will be received and considered by the Town Board of the Town of Cheektowaga on January 29, 2014 at 11:00 A.M., at the Town Hall, corner of Broadway and Union Roads, for Grant Funding Consultant Services for the Town of Cheektowaga for the 2014 calendar year.

Information and specifications may be obtained from the Town Clerk at her office in said Town Hall.

Proposals shall be submitted in a sealed envelope plainly marked on the outside "RFP - Grant Funding Consultant Services" and submitted to the Town Clerk prior to bid opening.

No bidder may withdraw his proposal within forty-five (45) days after the actual date of the opening thereof.

The Town Board reserves the right to consider informal any proposal not prepared and submitted in accordance with the provisions of the specifications and contract documents, and may waive any informalities, make an award to any company it determines to be in the best interest of the Town, or reject any or all bids.

BY ORDER OF THE TOWN BOARD OF THE TOWN OF CHEEKTOWAGA, ERIE COUNTY, NEW YORK.

ALICE MAGIERSKI
Town Clerk

DATED: January 6, 2014

RESULT: **ADOPTED [UNANIMOUS]**
MOVER: Mary Holtz, Supervisor
SECONDER: Gerald Kaminski, Councilmember
AYES: Holtz, Rogowski, Markel, Kaminski, Wozniak, Benczkowski, Meyers



23. RESOLUTION 2014-24

Authorize Town Clerk/Receiver of Taxes to Invest Tax Moneys

Sponsored By: Councilmember Wozniak, Councilmember Benczkowski

WHEREAS, the Town of Cheektowaga through and by its Receiver of Taxes and Assessments/Town Clerk, receives and collects Town taxes, and

WHEREAS, it is advantageous to the Town to invest these moneys in short-term savings accounts, certificates of deposit, municipal re-purchase agreements, etc., thereby creating revenues for the Town, and

WHEREAS, the Town Receiver of Taxes and Assessments/Town Clerk is knowledgeable about the methods of investment and institutions in which investments can be made, and

WHEREAS, the New York State Comptroller's Office has stated in Opinion Number 80-242, that a Town Board may authorize its Receiver of Taxes and Assessments to temporarily invest town tax moneys, and

WHEREAS, the County of Erie has also authorized the Receiver of Taxes and Assessments/Town Clerk to invest County tax moneys which the Town collects and to retain any interest therefrom to the Town's credit, NOW, THEREFORE, BE IT

RESOLVED, that Alice Magierski, Town Clerk/Receiver of Taxes and Assessments for the Town of Cheektowaga, be and hereby is authorized to invest real property tax moneys on a short-term basis in 2014, and BE IT FURTHER

RESOLVED, that any interest earned on such Town or County tax moneys shall be turned over to the Town of Cheektowaga General Fund.

RESULT:	ADOPTED [UNANIMOUS]
MOVER:	Angela M. Wozniak, Councilmember
SECONDER:	Diane Benczkowski, Councilmember
AYES:	Holtz, Rogowski, Markel, Kaminski, Wozniak, Benczkowski, Meyers



24. RESOLUTION 2014-25

Authorize Supervisor to Execute Agreement to Add Property to County in Rem Auction

Sponsored By: Councilmember Markel, Councilmember Rogowski

WHEREAS, the County of Erie, under the Erie County Tax Act, conducts In Rem Property Tax Foreclosures of properties for which property taxes have not been paid for three or more years, and

WHEREAS, property located at 44 Elmleaf Drive in the Town of Cheektowaga is legally eligible to be placed on the County foreclosure list, but, due to financial constraints, the County of Erie is not able to list it on the next In Rem auction, and

WHEREAS, Mosey Persico, LLP, the law firm which performs the legal work for the County for the In Rem foreclosures, has informed the Town that, in exchange for compensation equivalent to the cost to place this property on the In Rem list, they will add this eligible property to the In Rem foreclosure for 2014, and

WHEREAS, the Town of Cheektowaga is desirous of placing 44 Elmleaf Drive on the In Rem list as a means to save it and to have it occupied in order to preserve the neighborhood, NOW, THEREFORE, BE IT

RESOLVED, that this Town Board hereby requests Erie County and Mosey Persico, LLP to place 44 Elmleaf Drive on the next County In Rem, and BE IT FURTHER

RESOLVED, that moneys for said services, \$1,400.00, shall be appropriated from budget line item number 800.3620.4514.

RESULT:	ADOPTED [UNANIMOUS]
MOVER:	Charles Markel, Councilmember
SECONDER:	James P. Rogowski, Councilmember
AYES:	Holtz, Rogowski, Markel, Kaminski, Wozniak, Benczkowski, Meyers



25. RESOLUTION 2014-26

Authorize Tax Credit for Village of Depew

Sponsored By: Councilmember Rogowski, Supervisor Holtz

WHEREAS, Section 150 of the Town Law grants discretionary authority to a town for entry into an agreement with a village located partially within its boundaries having a police department of four (4) or more police officers on an annual full-time basis, to determine what part of the cost of the town police department shall be assessed against the property in the village, and

WHEREAS, the Village of Depew is located partially within the boundaries of the Town of Cheektowaga, and, in addition, the Village of Depew maintains a police department on an annual full-time basis, and

WHEREAS, the annual budget of the Town for the fiscal year beginning January 1, 2014 provides for a credit of \$440,000.00 to the Village of Depew for the cost of the Town Police Department assessed against the property in the Village of Depew, and

WHEREAS, a proposed agreement with the Village of Depew on the matter of the aforementioned credit has been prepared and reviewed, NOW, THEREFORE, BE IT

RESOLVED, that the aforesaid agreement is approved, and the Supervisor be and hereby is authorized and directed to execute same on behalf of the Town.

RESULT:	ADOPTED [UNANIMOUS]
MOVER:	James P. Rogowski, Councilmember
SECONDER:	Mary Holtz, Supervisor
AYES:	Holtz, Rogowski, Markel, Kaminski, Wozniak, Benczkowski, Meyers



26. RESOLUTION 2014-27

Purchase of Excess Workers Compensation Insurance

Sponsored By: Supervisor Holtz, Councilmember Kaminski

WHEREAS, the Town's excess workers compensation insurance expired on December 31, 2013, and

WHEREAS, the Town's insurance consultant solicited quotations for said excess workers compensation insurance, and

WHEREAS, Safety National Casualty Corporation, through First Niagara Risk Management, Inc., has submitted a quote for coverage with a \$650,000 retention for Police and a \$600,000 retention for other departments at a cost of \$96,664, NOW, THEREFORE, BE IT

RESOLVED, that this Town Board hereby agrees to purchase excess workers compensation insurance with a \$650,000 retention for Police and a \$600,000 retention for other departments from Safety National Casualty Corporation through Gallagher Bassett at a cost of \$96,664, and BE IT FURTHER

RESOLVED, that funds for said insurance shall be appropriated from budget line item 101.1722.4519.

RESULT:	ADOPTED [UNANIMOUS]
MOVER:	Mary Holtz, Supervisor
SECONDER:	Gerald Kaminski, Councilmember
AYES:	Holtz, Rogowski, Markel, Kaminski, Wozniak, Benczkowski, Meyers



27. RESOLUTION 2014-28

Application for New York State Affordable Housing Corporation Funding

Sponsored By: Councilmember Markel, Supervisor Holtz

WHEREAS, the New York State Affordable Housing Corporation is accepting applications for grant funding for home improvements programs, and

WHEREAS, said funds can be used in conjunction with Community Development Block Grant and HOME Investment Partnership funds to accomplish needed rehabilitation for low-to-moderate income homeowners, and

WHEREAS, the Town Community Development Office has prepared an application for submission to the State Affordable Housing Corporation for said funds, NOW, THEREFORE, BE IT

RESOLVED, that the Supervisor be and hereby is authorized to sign said application, and any related documents, and submit same to the New York State Affordable Housing Corporation for a grant of up to \$450,000 for "home improvements" for low-to-moderate income Town homeowners under the Affordable Home Ownership Development Program, as authorized by Section 1113(1) of the Private Housing Finance Law, and Be It

FURTHER RESOLVED, that a copy of this resolution be forwarded to State Assemblyman Dennis Gabryszak and State Senator Timothy Kennedy.

RESULT:	ADOPTED [UNANIMOUS]
MOVER:	Charles Markel, Councilmember
SECONDER:	Mary Holtz, Supervisor
AYES:	Holtz, Rogowski, Markel, Kaminski, Wozniak, Benczkowski, Meyers



28. RESOLUTION 2014-29

Approve Submission of FY2013 Annual CDBG Action Plan to HUD

Sponsored By: Councilmember Markel, Supervisor Holtz

WHEREAS, the Town of Cheektowaga is eligible to receive a revised \$929,383 in Community Development Block Grant Funds and \$223,447 in HOME Investment Partnership funds for the 2013 program year from the United States Department of Housing & Urban Development, and

WHEREAS, Public hearings regarding the use of said funds were held on November 5, 2012 and January 22, 2013, and

WHEREAS, the Town's Director of Community Development has submitted recommendations regarding the use of said funds, which includes activities to principally benefit low-income persons pursuant to the goals and objectives of the Housing and Community Development Act, as amended, and its governing rules and regulations, NOW, THEREFORE, BE IT

RESOLVED, that the Town Board hereby adopts and approves the submission of the Town of Cheektowaga Community Development Block Grant Program Annual Action Plan for 2013 to the Department of Housing and Urban Development for the 2013 Program Year, including the projects contained in the attached CDBG and HOME Project Summaries, and BE IT

FURTHER RESOLVED, that the Supervisor is hereby authorized to sign the required Certifications and any other Community Development Block Grant and HOME Program related documents as may be necessary, including annual grant agreements with the United States Department of Housing and Urban Development and all subrecipients specified in the approved 2013 Annual Action Plan.

Attachments:

Budget - 2013-Final Board Submittal Resolution (PDF)

RESULT:	ADOPTED [UNANIMOUS]
MOVER:	Charles Markel, Councilmember
SECONDER:	Mary Holtz, Supervisor
AYES:	Holtz, Rogowski, Markel, Kaminski, Wozniak, Benczkowski, Meyers



29. RESOLUTION 2014-30

Unsafe-Unsecured/191 Evergreen Place

Sponsored By: Councilmember Markel, Councilmember Kaminski

WHEREAS, Town of Cheektowaga Law for the Administration and Enforcement of the Codes of New York State; and the Property Maintenance Code of New York State require that all vacant structures and premises shall be maintained in clean, safe, secure and sanitary conditions so as not to cause a blighting problem or adversely affect the public health or safety and all nuisances abated, AND

WHEREAS, the Town of Cheektowaga has received notification of an unsafe structure and premises located at 191 Evergreen Place, Cheektowaga, New York SBL# 91.20-7-3 That is a danger to the safety of others, and records kept by the Assessors Office identify Barbara Jamieson, 198 Greenway Blvd, Cheektowaga, New York 14225, as the owner AND

WHEREAS, an inspection of such premises was conducted at 191 Evergreen Place, by the Housing and Neighborhood Preservation Office, AND

WHEREAS, such inspection found the premises to be deteriorated, vacant, a hazard, and a danger to the safety and well being of others, AND

WHEREAS, the Town of Cheektowaga Housing and Neighborhood Preservation Office properly notified the property owner in accordance with the Town of Cheektowaga Law for the Administration and Enforcement of the Codes of New York State, and the owner failed to take actions to safeguard the premises, AND

WHEREAS, these conditions require the Town of Cheektowaga Housing and Neighborhood Preservation Office to take immediate steps to safeguard the premises to protect the health and safety of others and abate all nuisances, NOW, THEREFORE BE IT

RESOLVED, that pursuant to Section 70-7A.(5) and Section 70-8 of the Town of Cheektowaga Law for the Administration and Enforcement of the Codes of New York State that the vacant structure premises be safeguarded and all nuisances abated; and all costs incurred be assessed against the property hereinbefore described.

RESULT:	ADOPTED [UNANIMOUS]
MOVER:	Charles Markel, Councilmember
SECONDER:	Gerald Kaminski, Councilmember
AYES:	Holtz, Rogowski, Markel, Kaminski, Wozniak, Benczkowski, Meyers



30. RESOLUTION 2014-31

Unsafe-Unsecured/36 Barbara Place

Sponsored By: Councilmember Markel, Councilmember Kaminski

WHEREAS, Town of Cheektowaga Law for the Administration and Enforcement of the Codes of New York State; and the Property Maintenance Code of New York State require that all vacant structures and premises shall be maintained in clean, safe, secure and sanitary conditions so as not to cause a blighting problem or adversely affect the public health or safety and all nuisances abated, AND

WHEREAS, the Town of Cheektowaga has received notification of an unsafe structure and premises located at 36 Barbara Place, Cheektowaga, New York SBL# 101.28-1-3 that is a danger to the safety of others, and records kept by the Assessors Office identify HSBC Bank USA, NA, 2929 Walden Avenue, Depew, New York 14043, as the owner AND

WHEREAS, an inspection of such premises was conducted at 36 Barbara Place, by the Housing and Neighborhood Preservation Office, AND

WHEREAS, such inspection found the premises to be deteriorated, vacant, a hazard, and a danger to the safety and well being of others, AND

WHEREAS, the Town of Cheektowaga Housing and Neighborhood Preservation Office properly notified the property owner in accordance with the Town of Cheektowaga Law for the Administration and Enforcement of the Codes of New York State, and the owner failed to take actions to safeguard the premises, AND

WHEREAS, these conditions require the Town of Cheektowaga Housing and Neighborhood Preservation Office to take immediate steps to safeguard the premises to protect the health and safety of others and abate all nuisances, NOW, THEREFORE BE IT

RESOLVED, that pursuant to Section 70-7A.(5) and Section 70-8 of the Town of Cheektowaga Law for the Administration and Enforcement of the Codes of New York State that the vacant structure premises be safeguarded and all nuisances abated; and all costs incurred be assessed against the property hereinbefore described.

RESULT:	ADOPTED [UNANIMOUS]
MOVER:	Charles Markel, Councilmember
SECONDER:	Gerald Kaminski, Councilmember
AYES:	Holtz, Rogowski, Markel, Kaminski, Wozniak, Benczkowski, Meyers



31. RESOLUTION 2014-32

Retain Firm of Grantmakers Advantage, Inc. for Grant Administration

Sponsored By: Supervisor Holtz, Councilmember Kaminski

WHEREAS, by Resolution 2012-17, this Town Board approved an Agreement with Grantmakers Advantage, Inc., for grant development, writing and administration services to the Town; and

WHEREAS, said Agreement expired December 31, 2013; and

WHEREAS, the Town desires to continue to engage the services of Grantmakers Advantage, Inc., on an hourly basis, to provide administrative and other necessary services as may be required for grants obtained during the term of the prior agreement; and

WHEREAS, Grantmakers Advantage, Inc., has agreed to continue to provide said services; NOW, THEREFORE, BE IT

RESOLVED, that the Supervisor be and hereby is authorized and directed to execute an agreement with Grantmakers Advantage, Inc., for the aforesaid services, for an hourly rate of \$65.00 per hour; and BE IT FURTHER

RESOLVED, that the fee stipulated in such agreement, \$65.00 per hour, shall be appropriated from budget line item number 0100-1220-4957.

RESULT:	ADOPTED [UNANIMOUS]
MOVER:	Mary Holtz, Supervisor
SECONDER:	Gerald Kaminski, Councilmember
AYES:	Holtz, Rogowski, Markel, Kaminski, Wozniak, Benczkowski, Meyers



32. RESOLUTION 2014-33

Retain Outside Accounting Consultant for 2014-2018

Sponsored By: Supervisor Holtz, Councilmember Kaminski

WHEREAS, the Town Board desires the services of a Certified Public Accounting firm that is knowledgeable of New York State, Federal and Town rules and regulations; knowledgeable of the New York State Uniform System of Accounting for towns; experienced in implementing Governmental Accounting Standards Board (GASB) Statements; established as Government Finance Officer Association Certificate Program reviewers; and familiar with the Town's policies, accounting procedures and operations in order to effectively and efficiently perform services in the areas of:

- A. Annual Audit - A complete financial audit of the Town's basic financial statements for the year ended December 31, 2013 and years ending December 31, 2014, 2015, 2016 and 2017.
- B. Compilation of the Annual Update Document to the Office of the State Comptroller of New York records for the year ended December 31, 2013, and years ending December 31, 2014, 2015, 2016 and 2017.
- C. Compilation of financial statements from the Town's records for the year ended December 31, 2013, and years ending December 31, 2014, 2015, 2016 and 2017.
- D. Preparation of management letter relating to observations during the audit of the basic financial statements.
- E. Single Audit - Conduct an audit of Town's federal financial assistance for compliance with applicable federal laws and regulations in accordance with OMB Circular A-133 for the year ended December 31, 2013, and years ending December 31, 2014, 2015, 2016 and 2017.
- F. Other Services - Including routine consultation will be provided to the Supervisor, Town Board and the Town's Director of Administration and Finance on areas such as: GASB implementations, state revenue sharing, borrowings, federal and state legislative developments, retirement, sales tax, compilation of various sewer billings and other areas as requested.
- G. Budget Compilation - Assistance and alternatives will be provided to the Supervisor, the Town Board and the Town's Director of Administration and Finance in various phases of the compilation of the 2015-2019 benefit basis and ad valorem budgets. Will assist/advise in the compilation of the Town's 2015-2019 tax rates for submission to Erie County.
- H. Audit of Departments. Audit the cash receipts and cash disbursements of the Tax Receiver, Town Clerk, Town Justices (2), the Parks, Recreation and Youth Services Department and the Senior Services Department for the year ended December 31, 2013, and years ending December 31, 2014, 2015, 2016 and 2017.
- I. Comprehensive Annual Financial Report - Will compile the Comprehensive Annual

Financial Report for the year ended December 31, 2013, and years ending December 31, 2014, 2015, 2016 and 2017 to be submitted to the Government Finance Officer's Association for review in the Certificate of Excellence in Financial Reporting Program.

- J. Compilation of Detailed Budget Presentation Document - Will compile the Town's 2015-2019 Budget Documents including departmental descriptions of pertinent responsibilities to the taxpayers, historical trends including year over year expenditure comparisons over the last three years, a table of contents and an index, and various colored charts and graphs.

and,

WHEREAS, Drescher and Malecki, LLP possesses the aforementioned attributes and is available to perform the services listed above, and

WHEREAS, this Town Board desires to retain the services of Drescher and Malecki, LLP to perform the services listed above, NOW, THEREFORE, BE IT

RESOLVED, that Drescher and Malecki, LLP be retained to perform the aforementioned services for the Town of Cheektowaga for the years 2014-2018 (which would entail the audits for the year ending December 31, 2013-2017) for a fee not to exceed \$94,500.00 each year, and BE IT FURTHER

RESOLVED, that Resolution 2011-25 be and hereby is modified for the Year 2014 by means of this resolution, and BE IT FURTHER

RESOLVED, that the Supervisor be and hereby is authorized and directed to execute a retainer agreement/letter with Drescher & Malecki, LLP for the above services.

RESULT:	ADOPTED [UNANIMOUS]
MOVER:	Mary Holtz, Supervisor
SECONDER:	Gerald Kaminski, Councilmember
AYES:	Holtz, Rogowski, Markel, Kaminski, Wozniak, Benczkowski, Meyers



33. RESOLUTION 2014-34

Establish Hourly Rates for Part-Time Employees

Sponsored By: Supervisor Holtz, Councilmember Kaminski

BE IT RESOLVED, that the hourly rates of the following Town part-time employees who are not covered by any bargaining unit be and hereby are established and set forth as follows, effective January 1, 2014:

NAME	HOURLY	TITLE
Justice Court	RATE	
BASZCZYNSKI, JILL	8.50	CLERK PART-TIME
DELANO, FAYE H	8.50	CLERK PART-TIME
IMIOLA, LYNN M.	8.50	CLERK PART-TIME
MATALONIS, WILLIAM	8.50	CLERK PART-TIME
SZCZEPANOWSKI, MARY ANN	10.25	CLERK PART-TIME
SZYMBORSKI, CHARLES	15.25	CLERK PART-TIME
WITKOWSKI, CHRISTINE	8.50	CLERK PART-TIME
ZAJDOWICZ, MARY ANN	15.25	CLERK PART-TIME
Accounting		
LEWANDOWSKI, LORRAINE	8.00	CLERK PART-TIME
Assessor		
ALMORABI, MARIESA	8.50	CLERK PART-TIME
Town Clerk		
CISKAL, TAMMY J	15.00	CLERK PART-TIME
DABB, MELISSA A	9.25	CLERK PART-TIME
DAWE, CHELSEA A	9.25	CLERK PART-TIME
GASIEWICZ, KATHLEEN	9.00	CLERK PART-TIME
GOUBA, KATHLEEN A	9.00	CLERK PART-TIME
KARASZEWSKI, LINDA	9.00	CLERK PART-TIME
MILLER, PATRICIA	9.50	CLERK PART-TIME
PANER, NANCY A	9.50	CLERK PART-TIME
SISTI, MARGARET M	9.50	CLERK PART-TIME
Law		
WILES, PATRICIA A	12.50	CLERK PART-TIME
Personnel		
KEHOE, BARBARA N	11.25	CLERK PART-TIME
Building Maintenance		
LAUBER, WILLIAM W	8.50	LABORER PART-TIME
MATECKI, JOHN G	8.50	LABORER PART-TIME
SCHEIB, GERALD P	8.50	LABORER PART-TIME

POCOBELLO, TYLER	8.25	LABORER SEASONAL
Records		
GALLAGHER, KAITLYN	9.25	CLERK PART-TIME
Police		
DOERR, SHEILA M	8.00	CLERK PART-TIME
FEDYNA, CHARLENE	8.00	CLERK PART-TIME
PECYNE, KEILEIGH	8.00	CLERK PART-TIME
REINHEIMER, ELIZABETH	8.50	CLERK PART-TIME
RICHARDSON, DEANA	8.50	CLERK PART-TIME
STROUD, MELISSA E	8.00	CLERK PART-TIME
SWIATEK, KRISTEN	8.00	CLERK PART-TIME
WACIENGA, BARBARA	8.25	CLERK PART-TIME
ZIELONKA, DENISE	8.25	CLERK PART-TIME
BARRY, KATHLEEN P	15.00	POLICE ATTENDANT PT
BUCZKOWSKI, MARY	15.00	POLICE ATTENDANT PT
CARNEY, JESSICA M	15.00	POLICE ATTENDANT PT
JAKUBOWICZ, COURTNEY	15.00	POLICE ATTENDANT PT
KISHBAUGH, JACQUELINE	15.00	POLICE ATTENDANT PT
KUWIK, KATHLEEN A	15.00	POLICE ATTENDANT PT
MARTIN, JENNIFER	15.00	POLICE ATTENDANT PT
MAYS, SARA L	15.00	POLICE ATTENDANT PT
REED, ANDREA	15.00	POLICE ATTENDANT PT
ROSS, JANIE L	15.00	POLICE ATTENDANT PT
SCHMITT, EMELIA N	15.00	POLICE ATTENDANT PT
SOBCZAK, LAURA A	15.00	POLICE ATTENDANT PT
BEEK, MARGARETA E	9.75	SCHOOL CROSSING GUARD
BENKLEMAN, BRENDA	9.75	SCHOOL CROSSING GUARD
CZERNIAK, MARIE A	9.75	SCHOOL CROSSING GUARD
FISCHER, DAWN M	9.75	SCHOOL CROSSING GUARD
JUSZKIEWICZ, ELAINE	9.75	SCHOOL CROSSING GUARD
KELLY, ANN M	9.75	SCHOOL CROSSING GUARD
KNOX, PATRICIA A	9.75	SCHOOL CROSSING GUARD
PAGE, ARTHUR F	12.00	SCHOOL CROSSING GUARD
SCHRUEFER, RICHARD	9.75	SCHOOL CROSSING GUARD
SZARY, JEAN M	9.75	SCHOOL CROSSING GUARD
WACHOWSKI, EMILY	9.75	SCHOOL CROSSING GUARD
BRZYSKI, KELLY A	8.00	STUDENT ASSISTANT
HOCKWATER, JENNA	8.00	STUDENT ASSISTANT
HOCKWATER, MICHAEL	8.00	STUDENT ASSISTANT
PECYNE, MADELYN O	8.00	STUDENT ASSISTANT
RUSSILLO, EMILY R	8.00	STUDENT ASSISTANT
SPEYER, MATTHEW J	8.00	STUDENT ASSISTANT

STROUD, MATTHEW J	8.40	STUDENT ASSISTANT
STROUD, SAMANTHA	8.15	STUDENT ASSISTANT
SZYMANSKI, SEAN T	8.00	STUDENT ASSISTANT
TURNBULL, MIRANDA	8.00	STUDENT ASSISTANT
BAILEY, BRIAN E	17.10	POLICE ATTENDANT PT
BENSON, TIMOTHY K	17.10	POLICE ATTENDANT PT
BUTLER, JOSEPH L	17.10	POLICE ATTENDANT PT
CEREMUGA, RICHARD	17.10	POLICE ATTENDANT PT
DEGUIRE, DAVID J	17.10	POLICE ATTENDANT PT
DUDZIAK, PHILLIP	17.10	POLICE ATTENDANT PT
DUNSHIE, JAMES L	17.10	POLICE ATTENDANT PT
DYL, MARK J	17.10	POLICE ATTENDANT PT
ENSER, ANDREW R.	17.10	POLICE ATTENDANT PT
JACOBS, JEFFREY A	17.10	POLICE ATTENDANT PT
JANORA, LEONARD R	17.10	POLICE ATTENDANT PT
KISHBAUGH, KENNETH	17.10	POLICE ATTENDANT PT
LOREFICE, PAUL W	17.10	POLICE ATTENDANT PT
LUKASIEWICZ, BRIAN	17.10	POLICE ATTENDANT PT
MARCINIAK, ROY H	17.10	POLICE ATTENDANT PT
MCFARLAND, NICHOLAS	17.10	POLICE ATTENDANT PT
MEKEEL, DOUGLAS J	17.10	POLICE ATTENDANT PT
MINGLE, MICHAEL J	17.10	POLICE ATTENDANT PT
O'ROURKE, WILLIAM	17.10	POLICE ATTENDANT PT
PILARSKI JR, RICHARD	17.10	POLICE ATTENDANT PT
PUNDT, STEVEN D	17.10	POLICE ATTENDANT PT
SCANZUSO, MICHAEL	17.10	POLICE ATTENDANT PT
SCHMITT, KEVIN P.	17.10	POLICE ATTENDANT PT
TAMARAZIO, JOSEPH	17.10	POLICE ATTENDANT PT
THERIAULT, ANTHONY	17.10	POLICE ATTENDANT PT
THOMAS, ROBERT J	17.10	POLICE ATTENDANT PT
TURNBULL, ARTHUR	17.10	POLICE ATTENDANT PT
WEIGAND, ERIC R	17.10	POLICE ATTENDANT PT
WILKOWSKI, DOUGLAS	17.10	POLICE ATTENDANT PT
WYNN, GARRETT A	17.10	POLICE ATTENDANT PT
Traffic Maintenance		
DEUSER, DAVID J	9.25	LABORER PART-TIME
Dog Control		
HOCKWATER, MATTHEW	10.50	ASST DOG CONTROL OFFICER PT
KANDEFER, AARON D	12.75	ASST DOG CONTROL OFFICER PT
MAGUDA, ANDREW D.	10.50	ASST DOG CONTROL OFFICER

		PT
MENTH, AMY L	10.50	ASST DOG CONTROL OFFICER PT
Facilities		
MEYERS, JOAN C	12.00	CLERK PART-TIME
BRUNDO, JAMES J	8.50	LABORER PART-TIME
FETTER, ROBERT D	8.50	LABORER PART-TIME
GALLETTA, JOSEPH	8.75	LABORER PART-TIME
GLUSZEK, JOHN E	8.50	LABORER PART-TIME
GRIFFIN, RICHARD	8.75	LABORER PART-TIME
GRINER, JUSTIN H	8.50	LABORER PART-TIME
HERKEY, NICHOLAS	8.50	LABORER PART-TIME
KANTOR, PATRICIA	8.75	LABORER PART-TIME
KRAWCZYK, THOMAS	8.75	LABORER PART-TIME
MACONAGHY JR, CRAIG	8.50	LABORER PART-TIME
OLEJNICZAK, DANIEL	8.75	LABORER PART-TIME
O'NEILL, CHRISTOPHER	8.50	LABORER PART-TIME
STOLL, JAMES K	8.50	LABORER PART-TIME
STUCKE SR, MARK P	8.75	LABORER PART-TIME
SUPERCZYNSKI, MARK	8.50	LABORER PART-TIME
SZYMCZUK, KAROL J	8.75	LABORER PART-TIME
KLUCK, ALEXANDER	8.50	LABORER SEASONAL
PAZDERSKI, MATTHEW	8.50	LABORER SEASONAL
Senior Services		
STIEGLER, LINDA S	10.60	CLERK PART-TIME
GALLAGHER, DIANE	8.85	LABORER PART-TIME
KIEDEL, JANINE M	8.85	LABORER PART-TIME
FOURNIER, MILDRED	9.10	REC ATTEN PT/SEASONA
KASPRZAK, CHRISTINE	10.00	REC ATTEN PT/SEASONA
KOLB, LINDA	10.00	REC ATTEN PT/SEASONA
PALISTRANT, ALICE	9.10	REC ATTEN PT/SEASONA
STEPNICK, NANCY A	9.10	REC ATTEN PT/SEASONA
ZULAWSKI, SHIRLEY	9.10	REC ATTEN PT/SEASONA
BENZINGER, ROBERT	10.00	VAN DRIVER PT
FARUGIA, JOSEPH P	10.00	VAN DRIVER PT
GABRYSZAK, ALEX J	10.00	VAN DRIVER PT
GEORGE, THOMAS E	10.00	VAN DRIVER PT
GRANAT, JOSEPH E	10.00	VAN DRIVER PT
KRUGER, GARY R	10.00	VAN DRIVER PT
LIEGL, SHAWN P	10.00	VAN DRIVER PT
LUMADUE, JOHN F	10.00	VAN DRIVER PT
MCGEE, CHERYL L	10.00	VAN DRIVER PT

NOWAK, LEONARD T	10.00	VAN DRIVER PT
PINSKI JR, STANLEY	10.00	VAN DRIVER PT
PRELL, MARY ELLEN	10.00	VAN DRIVER PT
STARK, GENE R	10.00	VAN DRIVER PT
STIEGLER, JOHN D	10.00	VAN DRIVER PT
WIERZBA, JILL M	10.00	VAN DRIVER PT
ZBYTEK, HARRY W	10.00	VAN DRIVER PT
ALBEE, CATHERINE	10.75	REC INSTRUCTOR PT
KAWA, KIMBERLY M	14.00	REC INSTRUCTOR PT
Community Development/Senior Services		
WOJCINSKI, PATRICIA	12.00	REC ATTEN PT/SEASONA
Sanitation		
KOTRYS, SHARON A	10.00	CLERK PART-TIME
ASHRAF, BRANDON A	10.00	LABORER PART-TIME
KRZEMIEN, AMANDA	9.25	LABORER PART-TIME
MCGLOIN, MICHAEL	9.25	LABORER PART-TIME
PIATEK, KEITH E	9.25	LABORER PART-TIME
VANOVERLOOP, KYLE	9.25	LABORER PART-TIME
BABCOCK, ANDREW P	9.25	LABORER SEASONAL
BOROWSKI, JUSTIN	9.25	LABORER SEASONAL
MERRITT, GREGORY	9.25	LABORER SEASONAL
Sewer		
BOBECK, AUSTIN J	9.00	LABORER PART-TIME
LATCHFORD, FRANK	9.00	LABORER PART-TIME
ROHLOFF, JOSEPH G	9.00	LABORER SEASONAL
Main Pump Station		
KLAFFKA, SHERYL A	10.50	CLERK PART-TIME
Highway		
INDELICATO, JOSEPHINE	9.25	CLERK PART-TIME
IRWIN, ROBERT J.E	9.25	LABORER SEASONAL
LATSHAW, JACOB M	9.25	LABORER SEASONAL
PACITTI, STEPHEN	9.25	LABORER SEASONAL
Code Enforcement		
FRONCZAK, GENEVIEVE	9.00	CLERK PART-TIME
KOPERA, JOSEPH J	12.75	ZONING INSPECTOR PART-TIME
GILL, GERALD J	13.25	HOUSING INSPECTOR PT
ROKITKA, LAWRENCE	13.25	HOUSING INSPECTOR PT

Motion by Councilmember Rogowski; Seconded by Councilmember Markel to waive the reading of names for this resolution. Motion Carried.

RESULT: **ADOPTED [UNANIMOUS]**
MOVER: Mary Holtz, Supervisor
SECONDER: Gerald Kaminski, Councilmember
AYES: Holtz, Rogowski, Markel, Kaminski, Wozniak, Benczkowski, Meyers



34. RESOLUTION 2014-35

Youth & Recreation Terminations

Sponsored By: Councilmember Wozniak, Councilmember Rogowski

BE IT RESOLVED that the individuals listed below be and herby are terminated in the Department of Youth & Recreational Services effective as indicated:

Lancelot Melin	12/17/13	14206
Sherry Maran	12/16/13	14227
Cinthia Radomski	12/16/13	14227
Angelina Rosati	10/16/13	14211

Motion by Councilmember Markel; Seconded by Councilmember Rogowski to waive the reading of names for the following two resolutions: 2014-35 and 2014-36. Motion Carried.

RESULT: ADOPTED [UNANIMOUS]
MOVER: Angela M. Wozniak, Councilmember
SECONDER: James P. Rogowski, Councilmember
AYES: Holtz, Rogowski, Markel, Kaminski, Wozniak, Benczkowski, Meyers



35. RESOLUTION 2014-36

Youth & Recreation Transfers

Sponsored By: Councilmember Wozniak, Councilmember Rogowski

BE IT RESOLVED that the below listed individual be transferred from Program Coordinator-Youth Board (Temporary) 7310.1901 to Recreation Attendant -7310.1814

Regular Part-time \$10.75 effective 1/14/14

Deanna Szymkowiak

BE IT FURTHER RESOLVED that the individuals listed below were on the Town Board Resolution dated 12/16/13 for a salary increase effective 01/01/14. They were terminated effective 08/16/13 from the Town Board Resolution dated 10/07/13.

Ross Bauman
Ariana D'Agostino

RESULT:	ADOPTED [UNANIMOUS]
MOVER:	Angela M. Wozniak, Councilmember
SECONDER:	James P. Rogowski, Councilmember
AYES:	Holtz, Rogowski, Markel, Kaminski, Wozniak, Benczkowski, Meyers



36. RESOLUTION 2014-37

Reappointment of Bingo Inspectors

Sponsored By: Councilmember Kaminski, Councilmember Markel

BE IT RESOLVED, that the following individuals be and hereby are reappointed as Bingo Inspectors, effective January 1, 2014 to December 31, 2014:

Katherine Ferdinand, Cheektowaga, New York
Dennis Smith, Cheektowaga, New York
Anthony Prep, Cheektowaga, New York

and BE IT FURTHER

RESOLVED, that the following individual be and hereby is reappointed Bingo Inspector Chairman, effective January 1, 2014 for a term of one year:

Thaddeus I. Marciniak, Cheektowaga, New York

RESULT:	ADOPTED [UNANIMOUS]
MOVER:	Gerald Kaminski, Councilmember
SECONDER:	Charles Markel, Councilmember
AYES:	Holtz, Rogowski, Markel, Kaminski, Wozniak, Benczkowski, Meyers



37. RESOLUTION 2014-38

Reappointment to Traffic Safety Commission

Sponsored By: Councilmember Meyers, Councilmember Rogowski

WHEREAS, the term of Cheektowaga Traffic Safety Commission Vice Chairman Paul Gasiewicz and Member Thaddeus Skowron expired on December 31, 2013 and

WHEREAS, Paul Gasiewicz and Thaddeus Skowron have expressed an interest in continuing to serve on the Traffic Safety Commission, and

WHEREAS, the Traffic Safety Commission has recommended that Paul Gasiewicz and Thaddeus Skowron be re-appointed to the Traffic Safety Commission, NOW, THEREFORE, BE IT

RESOLVED, that Paul Gasiewicz be and hereby is re-appointed as Vice Chairman of the Traffic Safety Commission and Thaddeus Skowron is reappointed as Member of the Traffic Safety Commission, effective immediately and terminating on December 31, 2016.

RESULT:	ADOPTED [UNANIMOUS]
MOVER:	Timothy J. Meyers, Councilmember
SECONDER:	James P. Rogowski, Councilmember
AYES:	Holtz, Rogowski, Markel, Kaminski, Wozniak, Benczkowski, Meyers



38. RESOLUTION 2014-39

Reappointments to Veterans Affairs Committee

Sponsored By: Councilmember Rogowski, Councilmember Meyers

WHEREAS, in order to keep this Town Board informed as to the needs of veterans in the Town, this Town Board created the Veterans Affairs Committee and appointed members thereto, and

WHEREAS, the members of the Veterans Affairs Committee serve for terms of one (1) year, and their terms expired on December 31, 2013, and

WHEREAS, this Board wishes to appoint the following members to a one (1) year term, NOW, THEREFORE, BE IT

RESOLVED, that the following individuals be and hereby are appointed to the Veterans Affairs Committee, effective January 1, 2014 and expiring on December 31, 2014:

J. Donald Griffin, Cheektowaga, New York
 Joseph Porempski, Cheektowaga, New York
 Karen Porempski, Cheektowaga, New York
 Earle Rosenthal, Cheektowaga, New York
 Elaine Rosenthal, Cheektowaga, New York
 George Ross, Angola Lake, New York
 Raymond Wolniewicz, Cheektowaga, New York
 John D. Stiegler, Cheektowaga, New York
 Wayne Sorrentino, Cheektowaga, New York
 Thomas J. Mazur, Cheektowaga, New York
 Jeff Sundquist, Depew, New York
 Kenneth Speaker, Cheektowaga, New York
 Stanley Blake, Lancaster, New York
 Nelson Oldfield, Cheektowaga, New York
 Richard Zydell, Cheektowaga, New York
 Joseph Reger, Cheektowaga, New York
 Owen Reger, Cheektowaga, New York
 Russell Freund, Depew, New York

RESULT:	ADOPTED [UNANIMOUS]
MOVER:	James P. Rogowski, Councilmember
SECONDER:	Timothy J. Meyers, Councilmember
AYES:	Holtz, Rogowski, Markel, Kaminski, Wozniak, Benczkowski, Meyers



39. RESOLUTION 2014-40

Reappointment of Zoning Board Chairman

Sponsored By: Councilmember Markel, Councilmember Rogowski

WHEREAS, the term of Robert Brandon as Chairman of the Zoning Board of Appeals expired on December 31, 2013, and

WHEREAS, Robert Brandon has expressed an interest in being reappointed to this position, and

WHEREAS, Robert Brandon has satisfactorily served as Chairman and Member of the Zoning Board of Appeals for a number of years and merits reappointment to such position, NOW, THEREFORE, BE IT

RESOLVED, that Robert Brandon of Cheektowaga, New York be and hereby is reappointed to the position of Chairman of the Zoning Board of Appeals, effective January 1, 2014 and terminating on December 31, 2018.

RESULT:	ADOPTED [UNANIMOUS]
MOVER:	Charles Markel, Councilmember
SECONDER:	James P. Rogowski, Councilmember
AYES:	Holtz, Rogowski, Markel, Kaminski, Wozniak, Benczkowski, Meyers



40. RESOLUTION 2014-41

Hiring/Termination of Part-Time/Seasonal Employees

Sponsored By: Councilmember Kaminski, Supervisor Holtz

BE IT RESOLVED, that the following individuals be and hereby are hired as **PART-TIME EMPLOYEES** in the departments listed, not to exceed nineteen (19) hours on a weekly basis, in compliance with Civil Service Laws and Regulations as well as the provisions of the Town's collective bargaining agreement between the Town of Cheektowaga and the Town of Cheektowaga Employees Association:

POLICE DEPARTMENT Police Attendant \$14.00/hour effective 1/7/14
Susan Bull, Cheektowaga, New York

FACILITIES DEPARTMENT (Buildings & Grounds Division) \$8.25/hour effective 12/23/13
Andrew M. Mays, Cheektowaga, New York

FACILITIES DEPARTMENT (Parks Division) \$8.25/hour effective 1/7/14
David D. Dankowski, Cheektowaga, New York
Robert J. Bommer III, Cheektowaga, New York

BE IT RESOLVED, that the following seasonal and/or part-time employees be and hereby are terminated as listed:

OFFICE OF THE TOWN ASSESSOR
Danette D. Brzozowski effective 10/22/13

POLICE DEPARTMENT
Kathleen A. Kuwik effective 1/19/13

Motion by Councilmember Rogowski; Seconded by Councilmember Markel to waive the reading of names for this resolution. Motion Carried.

RESULT: ADOPTED [UNANIMOUS]
MOVER: Gerald Kaminski, Councilmember
SECONDER: Mary Holtz, Supervisor
AYES: Holtz, Rogowski, Markel, Kaminski, Wozniak, Benczkowski, Meyers



41. RESOLUTION 2014-42

Travel Authorization Police Department - Crime Analysis Symposium (Lieutenant Brian Coons, Police Officers Thomas Rogers, Paul Nazzarett and Donald Szumigala)

Sponsored By: Councilmember Kaminski, Supervisor Holtz

WHEREAS, the Crime Analysis Symposium is being held January 9 through January 10, 2014 at the Rochester Institute of Technology; AND

WHEREAS, Lieutenant Brian Coons, Police Officers Thomas Rogers, Paul Nazzarett and Donald Szumigala have been recommended to attend said symposium; AND

WHEREAS, Police Chief David Zack has submitted a request for travel authorization along with the proper paperwork in a timely manner; AND

WHEREAS, the total cost to the Town shall not exceed \$439; AND

WHEREAS, these expenses have been budgeted by the Department; NOW, THEREFORE, BE IT

RESOLVED, that Lieutenant Brian Coons, Police Officers Thomas Rogers, Paul Nazzarett and Donald Szumigala be and hereby are authorized to attend the Crime Analysis Symposium being held January 9 through January 10, 2014 at the Rochester Institute of Technology.

RESULT:	ADOPTED [UNANIMOUS]
MOVER:	Gerald Kaminski, Councilmember
SECONDER:	Mary Holtz, Supervisor
AYES:	Holtz, Rogowski, Markel, Kaminski, Wozniak, Benczkowski, Meyers



42. RESOLUTION 2014-43

Travel Authorization Police Department - Property/Evidence Room Management (Lieutenant Patrick Chludzinski, Senior Property Clerk Annette Zachowicz)

Sponsored By: Councilmember Rogowski, Councilmember Kaminski

WHEREAS, a course entitled "Property/Evidence Room Management," is being held February 25 through February 26, 2014 in Onondaga County, New York; AND

WHEREAS, Lieutenant Patrick Chludzinski and Senior Property Clerk Annette Zachowicz have been recommended to attend said course; AND

WHEREAS, Police Chief David Zack has submitted a request for travel authorization along with the proper paperwork in a timely manner; AND

WHEREAS, the total cost to the Town shall not exceed \$594; AND

WHEREAS, these expenses have been budgeted by the Department; NOW, THEREFORE, BE IT

RESOLVED, that Lieutenant Patrick Chludzinski and Senior Property Clerk Annette Zachowicz be and hereby are authorized to attend a course entitled "Property/Evidence Room Management," being held February 25 through February 26, 2014 in Onondaga County, New York.

RESULT:	ADOPTED [UNANIMOUS]
MOVER:	James P. Rogowski, Councilmember
SECONDER:	Gerald Kaminski, Councilmember
AYES:	Holtz, Rogowski, Markel, Kaminski, Wozniak, Benczkowski, Meyers

IV. Suspension of Rules

Motion by Councilmember Rogowski; Seconded by Councilmember Markel to waive the Rules to Include the following two resolutions: 2014-44 and 2014-45. Motion Carried



1. RESOLUTION 2014-44

Approve Lease with National Fuel Gas Distribution Corporation

Sponsored By: Councilmember Kaminski, Supervisor Holtz

WHEREAS, previously the Cheektowaga Town Board authorized the Supervisor to execute a Meter and Regulator Lot Lease with National Fuel Gas Distribution Corporation to utilize Town-owned property on Kaufman Road near Harlem Road for the installation of a regulator station, relief valve and piping, and

WHEREAS, National Fuel Gas Distribution Corporation ("National Fuel") has requested the Town of Cheektowaga to renew this Meter and Regulator Lot Lease with it, and

WHEREAS, National Fuel has offered to remit annual lease payments of \$250 to the Town for five (5) years, and increases in rent every five (5) years thereafter, and

WHEREAS, the Town Engineer and Town Attorney have reviewed this request and the proposed location of the regulator station and have no objection to same, NOW, THEREFORE, BE IT

RESOLVED, that the Supervisor be and hereby is authorized and directed to execute a Meter and Regulator Lot Lease with National Fuel in accordance with the above, and BE IT FURTHER

RESOLVED, that this resolution is subject to permissive referendum under Town Law, and BE IT FURTHER

RESOLVED, that the Town Clerk be and hereby is directed to publish the attached Notice of Permissive Referendum in the Cheektowaga Bee.



NOTICE OF ADOPTION OF RESOLUTION SUBJECT TO PERMISSIVE REFERENDUM

NOTICE IS HEREBY GIVEN, that the Town Board of the Town of Cheektowaga, on January 6, 2014, adopted a resolution authorizing the Town of Cheektowaga to approve a Meter and Regulator Lot Lease with National Fuel Gas Distribution Corporation for the placement of a meter and appurtenances of Town-owned property located on Kaufman Road near Harlem

Road in the Town of Cheektowaga.

A copy of such Meter and Regulator Lot Lease is on file in the Town Clerk's Office where the same may be viewed during regular business hours.

TAKE FURTHER NOTICE, that such resolution is subject to permissive referendum under Article 7 of the Town Law of the State of New York.

BY ORDER OF THE TOWN BOARD OF THE TOWN OF CHEEKTOWAGA, ERIE COUNTY, NEW YORK.

Alice Magierski
Town Clerk

Dated: January 6, 2014

RESULT:	ADOPTED [UNANIMOUS]
MOVER:	Gerald Kaminski, Councilmember
SECONDER:	Mary Holtz, Supervisor
AYES:	Holtz, Rogowski, Markel, Kaminski, Wozniak, Benczkowski, Meyers



2. RESOLUTION 2014-45

Direct the Supervisor to Execute a Contract of Sale for the Rein Road Bridge Rehabilitation Project

Sponsored By: Councilmember Meyers, Supervisor Holtz

WHEREAS, by Resolution ID #6901 dated June 17, 2013, the Town Board established values for the purchase of a parcel of land and acquisition of a permanent easement over land adjacent to the Rein Road Bridge for the Rein Road Bridge Rehabilitation Project, PIN 5758.38, which land is owned by Voiture Local No. 51, 40 and 8, Inc., and

WHEREAS, detailed parcel maps and legal descriptions were prepared by Greenman Pedersen, Inc. on behalf of the Town for the proposed acquisition of a .02 acre parcel and a .04 acre permanent easement necessary to facilitate this bridge rehabilitation project, and an Appraisal Report and Technical Appraisal Review Report have been prepared concluding that the combined value of the fee parcel and permanent easement parcel total \$1,348.00, AND

WHEREAS, Voiture Locale No. 51, 40 and 8, Inc. has agreed to accept \$1,348.00 for said property and easement, and a Contract of Sale has been signed by said organization, and

WHEREAS, this Board wishes to proceed with the purchase of this property, NOW, THEREFORE, BE IT

RESOLVED, that the Town Supervisor, on behalf of this Town Board, is directed and authorized to execute the Contract of Sale for the acquisition of the above referenced property and easement, and all other documents necessary to effectuate the purchase of this property.

RESULT:	ADOPTED [UNANIMOUS]
MOVER:	Timothy J. Meyers, Councilmember
SECONDER:	Mary Holtz, Supervisor
AYES:	Holtz, Rogowski, Markel, Kaminski, Wozniak, Benczkowski, Meyers

V. Communications

A. Departmental Communications

1. Supervisor's Statement of Funds - September 2013
2. Supervisor's Statement of Funds - October 2013
3. Building Permit List - December 2013

4. Minutes: Cheektowaga Traffic Safety Commission - November 19, 2013***B. General Communications***

1. Notice of Claim: Dennis Cucinotta vs. Town of Cheektowaga
2. Notice of Claim: John P. Gozdziaak vs. Town of Cheektowaga
3. Notice of Claim: Ghazanfar Iqbal vs. Town of Cheektowaga
4. Notice of Claim: Kenneth J. Smith vs. Town of Cheektowaga
5. Notice of Claim: Peter V. Tonsoline vs. Town of Cheektowaga
6. Request to Speak: Donald Spahr Regarding Cars Blocking Sidewalks

VI. Comments***A. Supervisor's Comments******B. Councilmember's Comments******C. Public Comments*****VII. Adjournment**

Motion by Supervisor Holtz; Seconded by Councilmember Kaminski to adjourn the meeting in Memory of Richard Dean, decades-long member of the Cheektowaga Lions Club and Community Volunteer.

Alice Magierski, Town Clerk

Office of Economic & Community Development

**Town of Cheektowaga
Community Development Block Grant Program Budget
2013 Program Year**

Administration	\$ 242,083
Housing Rehabilitation - Single Family Owner-Occupied Units	442,042
Housing Rehabilitation - Multi-Family Owner-Occupied Units	30,000
<u>Rehabilitation Activity Delivery Costs</u>	206,843
\$200,326 - Inspections	
6,517 - Staff & other program expenses	
Environmental Hazard Testing (Lead Paint, Asbestos & Mold)	15,000
Dispositions	1,000
Acquisition	-
Public Safety - Police Foot Patrols	33,000
Housing Counseling Services	5,000
Domestic Violence Program	9,000
Fair Housing	200
Weatherization	5,000
Senior Citizen Services Outreach Assistant	9,000
Summer Day Camp for Children	21,000
<u>Village of Depew</u>	79,640
\$19,640 - Public Safety-Police Foot Patrols	
9,000 - Senior Citizen Van Driver	
11,000 - Senior Services Center Support Staff	
40,000 - Sidewalk Replacement	
<u>Village of Sloan</u>	28,170
\$4,000 – Youth Center Recreation Supplies and Equipment	
20,000 – Demolitions	
4,170 – Playground Equipment for Park	
Contingency - Un-programmed Funds	<u>4,001</u>
Total 2013 CDBG Allocation	929,383
Projected Revolving Program Income - Housing Rehabilitation	200,000
Projected Revolving Program Income - Economic Development	<u>300,000</u>
Total Projected Available Funds for CDBG Activities	<u>\$ 1,429,383</u>

Attachment: Budget - 2013-Final Board Submittal Resolution (RES-2014-29 : Approve FY2013 Annual CDBG Action Plan)

**Town of Cheektowaga
HOME Investment Partnership Program Budget
2013 Program Year**

First-Time Homebuyers Program.....	\$ 30,000
Loans of up to \$5,000 for closing cost/downpayment assistance for First-Time Homebuyers	
Housing Rehabilitation	165,815
Funds will be used for rehabilitation of owner-occupied housing units in the Town of Cheektowaga	
CHDO Operating Costs	<u>5,000</u>
Total HOME Funds	<u>\$ 223,447</u>

**Total Housing Rehabilitation Budget
(CDBG + HOME + NYS Affordable Housing Corp.)**

CDBG Housing Rehabilitation - Single Family Owner-Occupied Units.....	\$ 193,000
CDBG Housing Rehabilitation - Multi-Family Owner-Occupied Units.....	35,000
CDBG Housing Rehabilitation – Estimated Program Income	250,000
HOME Housing Rehabilitation – 2012 Entitlement Funds	198,447
HOME Housing Rehabilitation – Carry-Over from 2011	241,655
HOME Housing Rehabilitation – Estimated Program Income.....	75,000
NYS Affordable Housing Corp. – Anticipated Grant	<u>300,000*</u>
TOTAL Housing Rehabilitation Program Budget – All Sources	<u>\$ 1,293,102</u>

* Awaiting Determination from NYS Affordable Housing Corporation

Attachment: Budget - 2013-Final Board Submittal Resolution (RES-2014-29 : Approve FY2013 Annual CDBG Action Plan)



Town of Cheektowaga

Regular Meeting

~ Minutes ~

3301 Broadway
Cheektowaga, NY 14227
<http://www.town.cheektowaga.ny.us>

Alice Magierski
716-686-3400

Tuesday, January 21, 2014

6:45 PM

Council Chambers

I. Call to Order

6:45 PM Meeting called to order on January 21, 2014 at Council Chambers, 3301 Broadway St, Cheektowaga, NY.

Attendee Name	Organization	Title	Status	Arrived
Mary Holtz	Town of Cheektowaga	Supervisor	Present	
James P. Rogowski	Town of Cheektowaga	Councilmember	Present	
Charles Markel	Town of Cheektowaga	Councilmember	Present	
Gerald Kaminski	Town of Cheektowaga	Councilmember	Present	
Angela M. Wozniak	Town of Cheektowaga	Councilmember	Present	
Diane Benczkowski	Town of Cheektowaga	Councilmember	Present	
Timothy J. Meyers	Town of Cheektowaga	Councilmember	Present	

2. Additional Attendees

Ellen Fischer, Executive Director - Youth Board
Carla A. Kosmerl, Director of Community Development
Brian Krause, Director of Finance and Administration
Jeneen Lomando-McSkimming, Assessor
William Pugh, Town Engineer
Kevin Schenk, Town Attorney

II. Public Comment Period

III. Public Hearings

1. Amend Traffic Ordinance

COMMENTS - Current Meeting:

This being the time and place advertised for a Public Hearing, the Supervisor directed the Town Clerk to present that such notice has been duly published and posted; upon the order of the Supervisor such proof was duly filed.

The Supervisor announced that the Town Board would hear all persons interested in the subject of the hearing. Comments were heard, after which the Supervisor declared the hearing closed, decision was reserved.

RESULT: CLOSED [UNANIMOUS]
MOVER: Timothy J. Meyers, Councilmember
SECONDER: James P. Rogowski, Councilmember
AYES: Holtz, Rogowski, Markel, Kaminski, Wozniak, Benczkowski, Meyers

2. 2014 Community Development Block Grant Program

COMMENTS - Current Meeting:

This being the time and place advertised for a Public Hearing, the Supervisor directed the Town Clerk to present that such notice has been duly published and posted; upon the order of the Supervisor such proof was duly filed.

The Supervisor announced that the Town Board would hear all persons interested in the subject of the hearing. Comments were heard, after which the Supervisor declared the hearing closed, decision was reserved.

RESULT: CLOSED [UNANIMOUS]
MOVER: Diane Benczkowski, Councilmember
SECONDER: Mary Holtz, Supervisor
AYES: Holtz, Rogowski, Markel, Kaminski, Wozniak, Benczkowski, Meyers

IV. Resolutions



1. RESOLUTION 2014-46

Transfer of Funds-2013

Sponsored By: Supervisor Holtz, Councilmember Kaminski

BE IT RESOLVED, that the following transfer is hereby approved and made part hereof;

HIGHWAY

FROM:	300.5130.4462	Parts	\$10,000.00
	300.5110.4178	Blacktop General	13,500.00
	300.5150.4178	Blacktop	27,600.00
TO:	300.5140.4191	Miscellaneous	\$51,100.00

CDBG

FROM:	700.1013.0679	Summer Day Camp	\$1,249.86
	700.1013.0600	Housing Rehab-Single Family	23,961.17
TO:	700.1013.0600	Housing Rehab-Single Family	\$1,249.86
	700.1013.0752	Housing Rehab Costs-Staff & Expenses	13,451.17
	700.1013.0706	Housing Counseling Services	1,510.00
	700.1013.0680	Domestic Violence Investigation	9,000.00

RESULT:	ADOPTED [UNANIMOUS]
MOVER:	Mary Holtz, Supervisor
SECONDER:	Gerald Kaminski, Councilmember
AYES:	Holtz, Rogowski, Markel, Kaminski, Wozniak, Benczkowski, Meyers



2. RESOLUTION 2014-47

Warrant

Sponsored By: Councilmember Kaminski, Supervisor Holtz

BE IT RESOLVED, that the following Vouchers & Warrants submitted to the Town of Cheektowaga prior to January 21, 2014 are hereby approved and made part hereof;

GENERAL FUND	\$590,747.59
RISK RETENTION FUND	146,343.72
NYS HOME PROGRAM	
DEBT	31,724.79
HUD HOUSING REHABILITATION FUND	330.49
SPECIAL DISTRICTS FUND	618,006.62
HIGHWAY FUND	155,359.87
CAPITAL FUND	48,437.78
TRUST & AGENCY FUND	24,559.27
HUD CDBG FUND	426,329.93
PART TOWN FUND	4,474.31
NYS AFFORDABLE HOUSING	
	\$2,046,314.37

RESULT:	ADOPTED [UNANIMOUS]
MOVER:	Gerald Kaminski, Councilmember
SECONDER:	Mary Holtz, Supervisor
AYES:	Holtz, Rogowski, Markel, Kaminski, Wozniak, Benczkowski, Meyers



3. RESOLUTION 2014-48

Amend Resolution to Direct Supervisor to Execute a Contract of Sale for the Rein Road Bridge Project

Sponsored By: Supervisor Holtz, Councilmember Meyers

WHEREAS, by resolution dated January 6, 2014 (Resolution 2014-45), this Board directed the Supervisor to execute a contract of sale to acquire a small parcel of land and an easement for the Rein Road Bridge Rehabilitation Project, and

WHEREAS, the purchase price was incorrectly listed as \$1,348.00 whereas it should have been listed as \$1,386.00, NOW, THEREFORE, BE IT

RESOLVED, that the purchase price, as listed in Resolution 2014-45, be and hereby is revised to read \$1,386.00.

RESULT:	ADOPTED [UNANIMOUS]
MOVER:	Mary Holtz, Supervisor
SECONDER:	Timothy J. Meyers, Councilmember
AYES:	Holtz, Rogowski, Markel, Kaminski, Wozniak, Benczkowski, Meyers



4. RESOLUTION 2014-49

Award of Bid for Asbestos Survey and Air Monitoring Services for Property Located at 191 Evergreen Place (2014-03)

Sponsored By: Councilmember Markel, Supervisor Holtz

WHEREAS, pursuant to the Unsafe Buildings Law of the Town of Cheektowaga, this Town Board can require that unsafe buildings be either repaired or demolished; and

WHEREAS, the structures on property located at 191 Evergreen Place have experienced extensive deterioration and damage, and Nussbaumer & Clarke, Inc. determined that said structures are unsafe and recommended that they be demolished and removed; and

WHEREAS, by resolution adopted December 16, 2013, this Town Board ordered that the structures on said property be either repaired or demolished, and directed that the respective owner(s) or others responsible for the building on said property commence said repair or demolition work within 30 days; and

WHEREAS, more than 30 days have expired and no work has been commenced with respect to said property; and

WHEREAS, pursuant to the Unsafe Buildings Law, this Town Board can provide for the demolition of an unsafe building and assess the cost of same against the property; and

WHEREAS, prior to the demolition of said property, the Town needs to retain a firm to perform an asbestos survey and asbestos abatement plans for same; and

WHEREAS, on January 6, 2014, this Town Board issued a Notice to Bidders (Bid 2014-21 LAW) to various asbestos abatement firms and based on proposals submitted, the Town Attorney has recommended that this Town Board retain Aurora Environmental, LLC to perform said asbestos survey, specifications and project monitoring work for the sum of \$2,977.50 and, if required, a further sum of \$260.00 per day and \$6.95 per sample for additional air monitoring and sampling at the site, said proposal being the lowest responsible bid submitted; NOW, THEREFORE, BE IT

RESOLVED, that this Town Board hereby retains Aurora Environmental LLC, 1850 Davis Road, West Falls, New York 14170, to perform said asbestos survey and abatement work (if necessary) for 191 Evergreen Place for the sum of \$2,977.50 and if required, a further sum of \$260.00 per day and \$6.95 per sample for additional air monitoring and sampling at the site; and BE IT FURTHER

RESOLVED, that the Supervisor be and hereby is directed to execute an agreement with Aurora Environmental LLC for said services; and BE IT FURTHER

RESOLVED, that moneys for said services shall be appropriated from budget line item number 0800-800-0440.

RESULT: **ADOPTED [UNANIMOUS]**
MOVER: Charles Markel, Councilmember
SECONDER: Mary Holtz, Supervisor
AYES: Holtz, Rogowski, Markel, Kaminski, Wozniak, Benczkowski, Meyers



5. RESOLUTION 2014-50

Adoption of Full Value for Tax Assessments

Sponsored By: Supervisor Holtz, Councilmember Kaminski

WHEREAS, the Town of Cheektowaga currently maintains assessed values for residential and commercial properties in the Town at 62% of equalized full/market value of all such properties, and

WHEREAS, as a means to clear up questions that may pertain to assessments of properties within the Town of Cheektowaga, this Town Board has reviewed this matter fully and has met with the Town Assessor and our outside assessment consultant, and has determined that assessments; commencing with the 2014-15 tax assessment year, should be equalized to 100% of market value, NOW, THEREFORE, BE IT

RESOLVED, that, effective with the 2014-15 tax assessment year, the Town Board adopts in accordance to RPTL section 305 (3), a level of assessment at full value within the Town of Cheektowaga, and BE IT FURTHER

RESOLVED, that the Town Assessor and Emminger, Newton, Pigeon & Magyar, Inc. be and hereby are directed to take any and all actions to accomplish this 100% assessment in the Town of Cheektowaga, and BE IT FURTHER

RESOLVED, that the Assessor and/or Supervisor be and hereby are authorized and directed to execute any and all documents necessary to effectuate this change.

RESULT:	ADOPTED [5 TO 2]
MOVER:	Mary Holtz, Supervisor
SECONDER:	Gerald Kaminski, Councilmember
AYES:	Holtz, Markel, Kaminski, Wozniak, Benczkowski
NAYS:	James P. Rogowski, Timothy J. Meyers



6. RESOLUTION 2014-51

Call for a Public Hearing to Amend the Zoning Law

Sponsored By: Councilmember Markel, Councilmember Rogowski

WHEREAS, by resolution dated January 21, 1992, Local Law No. 1 of the Year 1992 of the Town of Cheektowaga, entitled "A Local Law Relating to Zoning" was adopted, and

WHEREAS, the Petitions Committee has recommended that the Zoning Law be amended:

1. to amend Section 260-23.A.(d) to eliminate the Town Zoning Law requirement for fencing around a yard where a pool exists;
2. to amend Section 260-37.(1)(i) to allow by means of special permits in the M2-General Manufacturing District:
 - a. Compressed Natural Gas filling stations;
 - b. Biomass Energy Conversion Facilities;
3. to amend Section 260-37.A.(2) to permit concrete crushing operations as an accessory use in a M2-General Manufacturing District;
4. to amend Section 260-44.B. and to enact a new section, Section 260-48, to regulate site lighting for non-residential and multifamily projects;
5. to add a new section, Section 260-454.B. to permit the temporary use of an automobile use area which is accessory to a permitted non-residential use, for the storage of deicing salts between November 1st and April 1st.
6. to amend Section 260-64 in relation to the restoration of damaged structures require commercial business signs to be removed within 30 days after a business leaves the premises.

, and

WHEREAS, a draft of such amendments has been prepared by the Town Building Inspections Department, NOW, THEREFORE, BE IT

RESOLVED, that a public hearing be held on the 3rd day of February, 2014 at 6:45 P.M. at the Town Hall, 3301 Broadway, Cheektowaga, New York to consider the advisability of adopting "A Local Law to Amend the Zoning Law", and BE IT FURTHER

RESOLVED, that the Town Clerk be and hereby is directed to publish the attached Notice of Hearing in the Cheektowaga Bee, and BE IT FURTHER

RESOLVED, that the Town Clerk be and hereby is directed to forward copies of this resolution and the attached Notice of Hearing to the Erie County Department of Environment and Planning, the City of Buffalo, and the Towns of West Seneca, Amherst and Lancaster, and the Villages of Sloan and Depew.

◆

NOTICE OF PUBLIC HEARING

NOTICE IS HEREBY GIVEN that, pursuant to the Municipal Home Rule Law of the State

of New York, a Public Hearing will be held before the Town Board of the Town of Cheektowaga on the 3rd day of February, 2014 at 6:45 P.M. at the Town Hall, 3301 Broadway, Cheektowaga, New York to consider and discuss and, if need be, act upon the proposed enactment of Local Law Intro No. 2014-1 of the Year 2014, entitled "A Local Law to Amend the Zoning Law". Following is a synopsis of the proposed Local Law Intro No. 2014-1:

Local Law Intro No. 2014-1

A Local Law to Amend the Zoning Law

Amend the following sections of the Zoning Law of the Town of Cheektowaga:

7. to amend Section 260-23.A.(d) to eliminate the Town Zoning Law requirement for fencing around a yard where a pool exists;
8. to amend Section 260-37.(1)(i) to allow by means of special permits in the M2-General Manufacturing District:
 - a. Compressed Natural Gas filling stations;
 - b. Biomass Energy Conversion Facilities;
9. to amend Section 260-37.A.(2) to permit concrete crushing operations as an accessory use in a M2-General Manufacturing District;
10. to amend Section 260-44.B. and to enact a new section, Section 260-48, to regulate site lighting for non-residential and multifamily projects;
11. to add a new section, Section 260-454.B. to permit the temporary use of an automobile use area which is accessory to a permitted non-residential use, for the storage of deicing salts between November 1st and April 1st.
12. to amend Section 260-64 in relation to the restoration of damaged structures require commercial business signs to be removed within 30 days after a business leaves the premises.

Dated: January 21, 2014

BY ORDER OF THE TOWN BOARD OF THE TOWN OF CHEEKTOWAGA, ERIE
COUNTY, NEW YORK.

ALICE MAGIERSKI, Town Clerk

RESULT:	ADOPTED [UNANIMOUS]
MOVER:	Charles Markel, Councilmember
SECONDER:	James P. Rogowski, Councilmember
AYES:	Holtz, Rogowski, Markel, Kaminski, Wozniak, Benczkowski, Meyers



7. RESOLUTION 2014-52

Notice to Bidders - One (1) Used Fork Lift (Bid #2014-4)

Sponsored By: Councilmember Kaminski, Supervisor Holtz

WHEREAS, the Central Garage is in need of one (1) used Fork Lift, NOW, THEREFORE, BE IT

RESOLVED, that the Town Clerk be and hereby is directed to publish a Notice to Bidders for the purchase of said Fork Lift for the Central Garage (Bid 2014-4), said notice to be published in the CHEEKTOWAGA BEE, AND, BE IT FURTHER

RESOLVED, that sealed bids will be received by the Town of Cheektowaga on February 5, 2014 at 11:00 am, at the Town Hall, at which time they will be publicly opened and read aloud.



NOTICE TO BIDDERS

Sealed proposals will be received by the Town of Cheektowaga on February 5, 2014 at 11:00 am at the Town Hall, corner of Broadway and Union Roads, for the purchase of one (1) used, Yale 4-Cylinder, Diesel Powered Fork Lift, or equal, for use by the Central Garage (Bid 2014-4).

Information for bidders and specifications may be obtained from the Town Clerk at her office in said Town.

The Town Board reserves the right to consider informal any bid not prepared and submitted in accordance with the provisions of the specifications and contract documents and may waive any informalities, make an award to other than the low bidder, should it be in the best interest of the Town, or reject any or all bids.

By order of the Town Board of the Town of Cheektowaga, Erie County, New York.

Alice Magierski, Town Clerk

DATED: January 21, 2014

RESULT:	ADOPTED [UNANIMOUS]
MOVER:	Gerald Kaminski, Councilmember
SECONDER:	Mary Holtz, Supervisor
AYES:	Holtz, Rogowski, Markel, Kaminski, Wozniak, Benczkowski, Meyers



8. RESOLUTION 2014-53

Notice to Bidders For Asbestos Survey for Property Located At 66 Westchester Drive (BID 2014-05 LAW)

Sponsored By: Councilmember Markel, Supervisor Holtz

WHEREAS, pursuant to the Town's Unsafe Buildings Law, Nussbaumer & Clarke, Inc., a duly authorized agent of the Town of Cheektowaga, has issued a written report stating that the structures located at **66 Westchester Drive** are unsafe and recommended that such structures be demolished; and

WHEREAS, the owners and/or lienholders of said property were notified to demolish the structures on said property, and no action for demolition has been taken to date; and

WHEREAS, a hearing was held in front of this Board on December 2, 2013 concerning said unsafe structures and the requested demolition; and

WHEREAS, the Town of Cheektowaga needs to take action to demolish the structures on said property in the event the owner of same does not do so; and

WHEREAS, prior to demolition of said property, the Town needs to have an asbestos survey done to determine whether there is asbestos in said structures; and

WHEREAS, a Notice to Bidders has been prepared for this matter; NOW, THEREFORE, BE IT

RESOLVED, that this Town Board hereby approves the Notice to Bidders for the Asbestos Survey for property located at **66 Westchester Drive** in the Town of Cheektowaga (Bid 2014-05 LAW); and BE IT FURTHER

RESOLVED, that the Town Clerk's Office be and hereby is directed to publish the attached Notice to Bidders in the CHEEKTOWAGA BEE; and BE IT FURTHER

RESOLVED, that bids for the Asbestos Survey, Specifications and Air Monitoring Services for 66 Westchester Drive shall be due no later than Wednesday, February 5, 2014 at 11:00 A.M. at the Town Clerk's Office, and BE IT FURTHER

RESOLVED, that the Town Clerk be and hereby is appointed as the officer to open said bids in the Council Chambers of Town Hall on Wednesday, February 5, 2014 at 11:00 a.m.



NOTICE TO BIDDERS

Sealed proposals will be received by the Town of Cheektowaga on Wednesday, February 5, 2014 at 11:00 A.M. at the Town Hall, 3301 Broadway, Cheektowaga, New York, for an asbestos survey, asbestos specifications preparation, and air monitoring services for residential property located at 66 Westchester Drive, Cheektowaga, New York (BID 2014-05

LAW).

Information for bidders and specifications may be obtained from the Town Clerk at her office in said Town.

The Town Board reserves the right to consider informal any bid not prepared and submitted in accordance with the provisions of the specification and contract documents, and may waive any informalities, make an award to other than the low bidder, or reject any or all bids should it be in the best interest of the Town.

BY ORDER OF THE TOWN BOARD OF THE TOWN OF CHEEKTOWAGA, ERIE COUNTY, NEW YORK.

Alice Magierski, Town Clerk

Dated: 21 January 2014

RESULT:	ADOPTED [UNANIMOUS]
MOVER:	Charles Markel, Councilmember
SECONDER:	Mary Holtz, Supervisor
AYES:	Holtz, Rogowski, Markel, Kaminski, Wozniak, Benczkowski, Meyers



9. RESOLUTION 2014-54

Notice to Bidders - Demolition with Asbestos Abatement of 137 David Avenue (BID 2014-06 LAW)

Sponsored By: Councilmember Markel, Supervisor Holtz

WHEREAS, it is in order that bids be advertised for the demolition and asbestos abatement of structures located at 137 David Avenue, Cheektowaga, New York; and

WHEREAS, specifications for same have been prepared by Nussbaumer & Clarke, Inc.;
NOW, THEREFORE, BE IT

RESOLVED, that the Town Clerk be and hereby is directed to publish a Notice to Bidders (BID 2014-06 LAW) for the demolition and asbestos abatement of structures located at 137 David Avenue, said notice to be published in the CHEEKTOWAGA BEE, and BE IT FURTHER

RESOLVED, that sealed bids will be received and opened by the Town Clerk at a public bid opening to be held in the Council Chambers at the Cheektowaga Town Hall on Wednesday, February 5, 2014 at 11:00 A.M.



NOTICE TO BIDDERS

Sealed proposals will be received by the Town Clerk of the Town of Cheektowaga on Wednesday, February 5, 2014 at 11:00 A.M. at the Cheektowaga Town Hall, 3301 Broadway, Cheektowaga, New York, for the demolition and asbestos abatement of structures located at 137 David Avenue (BID 2014-06 LAW), situate in the Town of Cheektowaga, New York.

Information for bidders and specifications may be obtained from the Town Clerk at her office in said Town.

The Town Board reserves the right to consider informal any bid not prepared and submitted in accordance with the provisions of the specification and contract documents, and may waive any informalities, make an award to other than the low bidder, or reject any or all bids should it be in the best interest of the Town.

BY ORDER OF THE TOWN BOARD OF THE TOWN OF CHEEKTOWAGA, ERIE COUNTY, NEW YORK.

Alice Magierski, Town Clerk

Dated: 21 January 2014

RESULT:	ADOPTED [UNANIMOUS]
MOVER:	Charles Markel, Councilmember
SECONDER:	Mary Holtz, Supervisor
AYES:	Holtz, Rogowski, Markel, Kaminski, Wozniak, Benczkowski, Meyers



10. RESOLUTION 2014-55

Authorize Town Clerk to Issue New/Renewal Ambulance Drivers/Attendants Licenses

Sponsored By: Councilmember Wozniak, Councilmember Benczkowski

WHEREAS, on the 7th day of May, 1984, this Town Board adopted an Ambulance Ordinance. The EMS Board, which was created at that time, has completed a review and evaluation of new/renewal license applications for driver(s)/attendant(s), and has recommended that the Town Board issue such licenses, NOW, THEREFORE BE IT

RESOLVED, that the recommendations of the EMS Board concerning the licensing of new/renewal driver(s)/attendant(s) shown on the list below be and hereby are accepted and approved, for a period to expire upon the expiration of such ambulance driver(s)/attendant(s) Emergency Medical Technician ('EMT') card and, BE IT FURTHER

RESOLVED, that the Town Clerk be and hereby is authorized, empowered and directed to issue new/renewal licenses to the driver(s)/attendant(s) set forth on the annexed schedule, pursuant to the terms of this resolution.

TOWN OF CHEEKTOWAGA DRIVER/ATTENDANT LICENSE LIST

<u>Name</u>	<u>Expiration Date</u>
Accurso, Mark Anthony , ,	10/31/2016
Adams, Maxwell H. , ,	2/29/2016
Ast, Brent P , ,	6/30/2016
Atkinson, Andrew J , ,	10/31/2016
Bair, Aaron J , ,	3/31/2015
Ball, Tracey C. , ,	8/31/2016
Barkey, Eric N , ,	9/30/2015
Bauer, Brittany J , ,	6/30/2016
Bertino II, Thomas M , ,	10/31/2016
Biedron, Seth M , ,	6/30/2016
Bornhoeft, Matthew J , ,	8/31/2016
Brown, Sabrina M. , ,	8/31/2016
Burghdurf, Christopher R , ,	6/30/2016
Burke, Peter J , ,	9/30/2016
Burrows, Timothy R , ,	9/30/2016
Butts, Joseph C , ,	10/31/2016
Casper, Joseph J , ,	9/30/2016

Chapin, Colin M	, ,	6/30/2015
Cinelli, Jon N	, ,	10/31/2016
Clemons, David C	, ,	12/31/2016
Dalton, Kevin R	, ,	10/31/2016
DeBerry-Nelson, Jordan C	, ,	8/31/2016
Drzal, Colleen M	, ,	12/31/2015
Dudelson, Jordan R	, ,	9/30/2016
Dysard, Andrew D.	, ,	9/30/2016
Edwards, Brian D	, ,	9/30/2016
Fisher, Malachi M	, ,	10/31/2016
Frazzini, Brittany H	, ,	9/30/2016
Galmarini, Luke R	, ,	2/29/2016
Gambino, Ashley L	, ,	9/30/2016
Gastle, David J	, ,	12/31/2016
Gates, Joshua R	, ,	9/30/2014
Gill, Jonathan A	, ,	10/31/2016
Horwood, Breanna K	, ,	7/31/2016
Jarvis, David J	, ,	8/31/2016
Jerozal, Bernard A	, ,	6/30/2015
Kerr, William R.	, ,	8/31/2016
Kornowicz, Allen J Jr	, ,	10/31/2016
Krieger, Chelsea R	, ,	9/30/2016
Lama, Richard J	, ,	12/31/2016
Lengen, Joshua K	, ,	9/30/2016
LeRocque, Mitchell R	, ,	7/31/2015
Long, Steven	, ,	7/31/2015
Martinez, David	, ,	10/31/2016
Matheis, Scott C	, ,	9/30/2016
McCartin, Robert W	, ,	6/30/2016
McGinnis, Eric T	, ,	9/30/2016
Meier, James F Jr	, ,	11/30/2016
Meyer, Spencer L	, ,	10/31/2016
Miller, Jacob A	, ,	11/30/2016
Myers, Joshua T	, ,	1/31/2016
Nati, Frank A	, ,	9/30/2016
Neuman, William M.	, ,	10/31/2016
Palumbo, William C	, ,	11/30/2016

Perry, Danielle N	, ,	1/31/2015
Peters, Jodi L	, ,	8/31/2016
Randall, Peter J	, ,	7/31/2016
Reid, Derek M	, ,	8/31/2016
Reilly, Elizabeth A	, ,	1/31/2016
Rewinski, Lisa R.	, ,	8/31/2016
Richardson, Christopher M ,	, ,	8/31/2016
Ring, Alan J	, ,	6/30/2016
Rogacki, Shawn E	, ,	9/30/2016
Rusinski, John M	, ,	10/31/2016
Samol, Michael J	, ,	7/31/2015
Saxer, Christopher M	, ,	6/30/2016
Smarr, Holly L	, ,	7/31/2016
Smerka, Brittanie S	, ,	6/30/2016
Smith, Tristan H	, ,	9/30/2016
Solem, Nicholas D.	, ,	8/31/2016
Stromecki, Courtney E	, ,	9/30/2014
Walters, Bradley M	, ,	8/31/2014
Ward, Justin C.	, ,	6/30/2016
Weber, William R	, ,	9/30/2016
Weinstein, Jarin S	, ,	5/31/2015
Williams, Alan E	, ,	7/31/2016
Yunusov, Bekhzod N	, ,	9/30/2016
Zimmerman, Sarah E	, ,	8/31/2016

RESULT:	ADOPTED [UNANIMOUS]
MOVER:	Angela M. Wozniak, Councilmember
SECONDER:	Diane Benczkowski, Councilmember
AYES:	Holtz, Rogowski, Markel, Kaminski, Wozniak, Benczkowski, Meyers



11. RESOLUTION 2014-56

Authorize Supervisor to Sign Amendment No. 2 to the General Technical Services Agreement with URS Corporation - New York

Sponsored By: Councilmember Meyers, Supervisor Holtz

WHEREAS, by resolution dated May 5, 2008 the Town Board authorized the Supervisor to execute a three (3) year agreement for General Technical Services with URS Corporation - New York to assist the Town in performing long term operation and maintenance (O&M) activities at the Pfohl Brothers Landfill Site as required under a Settlement Agreement between the Pfohl Brothers Site Steering Committee and the Town consistent with the Operation and Maintenance Plan approved by the New York State Department of Environmental Conservation, AND

WHEREAS, by resolution dated February 23, 2011 the term of the aforesaid Technical Services Agreement was subsequently extended to December 31, 2013 following the Town Board's acceptance of Contract Amendment No. 1, AND

WHEREAS, there is a need to continue to perform long term monitoring, operation and maintenance activities at the Pfohl Brothers Landfill Site and the Town Engineer has recommended that the aforesaid Technical Services Agreement, which expired on December 31, 2013, be extended in accordance with Amendment No. 2 to the May 5, 2008 General Technical Services Agreement, AND

WHEREAS, Amendment No. 2 provides for the extension of the aforesaid May 5, 2008 Agreement for calendar years 2014, 2015 and 2016, expiring on December 31, 2016, NOW, THEREFORE, BE IT

RESOLVED, that Amendment No. 2 to the General Technical Services Agreement dated May 5, 2008 providing for its extension for three (3) additional calendar years covering 2014, 2015 and 2016 and expiring on December 31, 2016, as recommended by the Town Engineer and reviewed by the Town Attorney, is approved and accepted, AND, BE IT FURTHER

RESOLVED, that the Supervisor is hereby directed and authorized to sign Amendment No. 2 to the General Technical Services Agreement with URS Corporation - New York, 77 Goodell Street, Buffalo, New York 14203, AND, BE IT FURTHER

RESOLVED, that professional service fees shall be chargeable to Account No. 150-1910-5901.

RESULT:	ADOPTED [UNANIMOUS]
MOVER:	Timothy J. Meyers, Councilmember
SECONDER:	Mary Holtz, Supervisor
AYES:	Holtz, Rogowski, Markel, Kaminski, Wozniak, Benczkowski, Meyers



12. RESOLUTION 2014-57

Authorize Supervisor to Sign Agreement with Nussbaumer & Clarke, Inc. for Professional Services

Sponsored By: Councilmember Meyers, Supervisor Holtz

WHEREAS, as part of the operation and maintenance responsibilities associated with the Town's Consolidated Sanitary Sewer District Facilities, Town buildings, various Town-wide infrastructure and major drainage systems, the Town must occasionally rely on engineering consultant technical assistance to resolve problems as they may occur, and has found it beneficial to conduct preventative maintenance inspections to insure efficient facilities operation, AND

WHEREAS, there is need to continue to obtain specialized technical assistance in order to assure continuous uninterrupted efficient operation of sanitary sewer system facilities, Town facilities and infrastructure components, AND

WHEREAS, said services are essential in assisting the Town with long term stormwater and drainage system improvement initiatives, management and regulatory compliance associated with the operation and maintenance of Town sanitary sewer districts, and in securing grant monies available through various State and Federal programs, AND

WHEREAS, the engineering consulting firm of Nussbaumer & Clarke, Inc. has been found qualified to perform such services and has vast knowledge and experience in the operation of the Town's infrastructure, NOW, THEREFORE, BE IT

RESOLVED, that the agreement for general technical services for calendar years 2014 through 2016, as submitted by the consulting firm of Nussbaumer & Clarke, Inc. and as recommended by the Town Engineer and reviewed by the Town Attorney, is approved and accepted, AND, BE IT FURTHER

RESOLVED, that the professional fees shall be based on the hourly rates established in the agreement and shall be chargeable to the Consolidated Sanitary Sewer District, Town-Wide Drainage District or other appropriate departmental accounts as budgeted and when authorized by the Town Engineer or Departmental Supervisor, AND, BE IT FURTHER

RESOLVED, that the Supervisor is directed and authorized to sign said agreement for professional services with Nussbaumer & Clarke, Inc., 3556 Lake Shore Road, Buffalo, New York 14219-1494.

RESULT:	ADOPTED [UNANIMOUS]
MOVER:	Timothy J. Meyers, Councilmember
SECONDER:	Mary Holtz, Supervisor
AYES:	Holtz, Rogowski, Markel, Kaminski, Wozniak, Benczkowski, Meyers



13. RESOLUTION 2014-58

Authorize Purchase of Copy Machine for Senior Services Department

Sponsored By: Supervisor Holtz, Councilmember Kaminski

WHEREAS, the Senior Services Department is in need of a new copier machine; and

WHEREAS, Erie 1 Board of Cooperative Educational Services ("BOCES") solicited bids for the purchase of photocopiers for use by them, school districts and municipalities in the Western New York area; and

WHEREAS, the New York State General Municipal Law, Section 103, authorizes the purchase by the Town of said photocopiers under contracts let by any other agency of the State, provided said contract was let in a manner that constituted competitive bidding consistent with State Law, and further that provision was made in the bid documents enabling municipalities to utilize said bid award, thereby eliminating the need for competitive bidding by the Town and thus allowing "piggybacking" off the BOCES' bid; and

WHEREAS, the BOCES' bid documents and award contained such provisions; and

WHEREAS, a local vendor, Eagle Systems, Inc., was a successful bidder and was awarded the bid by BOCES (BOCES Bid #CE060713C) and is an authorized dealer for Toshiba copiers under said contract; and

WHEREAS, the Town of Cheektowaga solicited a quotation from Eagle Systems to purchase a copy machine for the Senior Services Department; NOW, THEREFORE, BE IT

RESOLVED, that this Town Board agrees to purchase a Toshiba eStudio 356 copy machine through the contract awarded by Erie 1 Board of Cooperative Educational Services ("BOCES"), Bid #CE060713C, utilizing a local vendor/authorized dealer, Eagle Systems, Inc., 2421 Harlem Road, Cheektowaga, New York 14225, at a total cost not to exceed \$2,108.00, said cost including delivery, surge protector, installation on servers or workstations, and removal and return of the hard drive on the present copier to the Town of Cheektowaga for destruction; and BE IT FURTHER

RESOLVED, that the cost per copy for maintenance and supplies for said copier for a guaranteed two-year period, commencing on the date of installation of said copier, will be \$0.008 per black and white copy; and BE IT FURTHER

RESOLVED, that moneys for said purchase shall be appropriated from line item 100.7620.4432 in said department's budget; and BE IT FURTHER

RESOLVED, that the Supervisor be and hereby is authorized and directed to execute all documents and maintenance agreements with Eagle Systems, Inc., to effectuate the purchase subject to the review and approval of same by the Town Attorney.

RESULT:	ADOPTED [UNANIMOUS]
MOVER:	Mary Holtz, Supervisor
SECONDER:	Gerald Kaminski, Councilmember
AYES:	Holtz, Rogowski, Markel, Kaminski, Wozniak, Benczkowski, Meyers



14. RESOLUTION 2014-59

Authorize Purchase of Copy Machine for Youth & Recreation Department

Sponsored By: Supervisor Holtz, Councilmember Wozniak

WHEREAS, due to heavy usage and age, a copy machine in the Youth & Recreation Department is experiencing many breakdowns requiring frequent service calls and maintenance; and

WHEREAS, Erie 1 Board of Cooperative Educational Services ("BOCES") solicited bids for the purchase of photocopiers for use by them, school districts and municipalities in the Western New York area; and

WHEREAS, the New York State General Municipal Law, Section 103, authorizes the purchase by the Town of said photocopiers under contracts let by any other agency of the State, provided said contract was let in a manner that constituted competitive bidding consistent with State Law, and further that provision was made in the bid documents enabling municipalities to utilize said bid award, thereby eliminating the need for competitive bidding by the Town and thus allowing "piggybacking" off the BOCES' bid; and

WHEREAS, the BOCES' bid documents and award contained such provisions; and

WHEREAS, a local vendor, Eagle Systems, Inc., was a successful bidder and was awarded the bid by BOCES (BOCES Bid #CE060713C) and is an authorized dealer for Toshiba copiers under said contract; and

WHEREAS, the Town of Cheektowaga solicited a quotation from Eagle Systems to purchase a copy machine for the Youth & Recreation Department; NOW, THEREFORE, BE IT

RESOLVED, that this Town Board agrees to purchase a Toshiba eStudio 3055c copy machine through the contract awarded by Erie 1 Board of Cooperative Educational Services ("BOCES"), Bid #CE060713C, utilizing a local vendor/authorized dealer, Eagle Systems, Inc., 2421 Harlem Road, Cheektowaga, New York 14225, at a total cost not to exceed \$4,724.00, said cost including delivery, surge protector, installation on servers or workstations, and removal and return of the hard drive on the present copier to the Town of Cheektowaga for destruction; and BE IT FURTHER

RESOLVED, that the cost per copy for maintenance and supplies for said copier for a guaranteed two-year period, commencing on the date of installation of said copier, will be \$0.008 per black and white copy and \$0.06 per color copy; and BE IT FURTHER

RESOLVED, that moneys for said purchase shall be appropriated from equipment line items in said department's budget; and BE IT FURTHER

RESOLVED, that the Supervisor be and hereby is authorized and directed to execute all documents and maintenance agreements with Eagle Systems, Inc., to effectuate the purchase subject to the review and approval of same by the Town Attorney.

RESULT: **ADOPTED [UNANIMOUS]**
MOVER: Mary Holtz, Supervisor
SECONDER: Angela M. Wozniak, Councilmember
AYES: Holtz, Rogowski, Markel, Kaminski, Wozniak, Benczkowski, Meyers



15. RESOLUTION 2014-60

Approve Purchase of Two (2) Tandem Axle Cab/Chassis with Dump Body and plow equipment

Sponsored By: Councilmember Kaminski, Supervisor Holtz

WHEREAS, The Highway Department has requested authorization to purchase two (2) 2014 T470 Tandem Axle Cab/Chassis with Dump Body and plow equipment, as specified in County of Onondaga Division of Purchase Contract, Bid Ref. #7823, contract period: June 24, 2013 through June 23, 2018, AND

WHEREAS, funds for said purchase have been budgeted and are available under account number 300-5130-2407, NOW THEREFORE BE IT,

RESOLVED, that the Town Board hereby authorizes the purchase of two (2) 2014 T470 Tandem Axle Cab/Chassis with Dump Body and plow equipment in the amount of \$402,392.00 from:

Kenworth Northeast Group
100 Commerce Drive
Buffalo, NY 14218

RESULT:	ADOPTED [UNANIMOUS]
MOVER:	Gerald Kaminski, Councilmember
SECONDER:	Mary Holtz, Supervisor
AYES:	Holtz, Rogowski, Markel, Kaminski, Wozniak, Benczkowski, Meyers



16. RESOLUTION 2014-61

Approve Purchase of Two (2) 2014 Ford F-350 XL Reg Cab 2WD

Sponsored By: Councilmember Kaminski, Supervisor Holtz

WHEREAS, The Highway Department has request authorization to purchase Two (2) 2014 Ford F-350 XL Reg Cab 2WD

WHEREAS, the purchase of the equipment is subject to various NYS laws regarding purchasing of equipment including but not limited to GML Section 103, And

WHEREAS, GML 103 (16) permits the purchase of equipment, etc. through the use of a contract let by a political subdivision of NYS if such political subdivision's contract was let in a manner that constitutes competitive bidding consistent with NYS law and is made available for use by other governmental entities, AND

WHEREAS, as specified in the Chautauqua County DOP, Bid Results Proposal Number E-12-13 PFTH dated November 26, 2013, making its bidding procedures available to other governmental entities in accordance with GML Section 103 (16), AND

WHEREAS, the Cheektowaga Highway Department has reviewed the bidding materials and procedures compiled by the Chautauqua County DOP, and have determined that same are compliant with NYS law including GML 103, NOW THEREFORE BE IT,

RESOLVED, that the Town Board hereby authorizes the purchase of two (2) 2014 Ford F-350 XL Reg Cab 2WD in the amount of \$63,047.56 from Van-Bortel Ford, 71 Marsh Road, East Rochester, NY 14445, where funds for said purchase have been budgeted and is available under account number 300-5130-2407.

RESULT:	ADOPTED [UNANIMOUS]
MOVER:	Gerald Kaminski, Councilmember
SECONDER:	Mary Holtz, Supervisor
AYES:	Holtz, Rogowski, Markel, Kaminski, Wozniak, Benczkowski, Meyers



17. RESOLUTION 2014-62

Approve Purchase of 2014 RAVO 5 Series Street Sweeper

Sponsored By: Councilmember Kaminski, Supervisor Holtz

WHEREAS, The Highway Department has request authorization to purchase a 2014 RAVO 5 Series Street Sweeper with options and

WHEREAS, the purchase of the equipment is subject to various NYS laws regarding purchasing of equipment including but not limited to GML Section 103, And

WHEREAS, GML 103 (16) permits the purchase of equipment, etc. through the use of a contract let by a political subdivision of NYS if such political subdivision's contract was let in a manner that constitutes competitive bidding consistent with NYS law and is made available for use by other governmental entities, AND

WHEREAS, the Village of Williamsville, NY advertised for a street sweeper on June 12, 2013, and did make its bidding procedures available to other governmental entities in accordance with GML Section 103 (16), AND

WHEREAS, the Cheektowaga Highway Department has reviewed the bidding materials and procedures compiled by the Village of Williamsville and have determined that same are compliant with NYS law including GML 103, NOW THEREFORE BE IT,

RESOLVED, that the Town Board hereby authorizes the purchase of a 2014 RAVO 5 Series Street Sweeper with options in the amount of \$190,253.00 from Upstate Sweepers and Rentals, Inc., 1999 Mt. Read Blvd., Rochester, NY 14615, where funds for said purchase have been budgeted and is available under account number 300-5130-2407.

RESULT:	ADOPTED [UNANIMOUS]
MOVER:	Gerald Kaminski, Councilmember
SECONDER:	Mary Holtz, Supervisor
AYES:	Holtz, Rogowski, Markel, Kaminski, Wozniak, Benczkowski, Meyers



18. RESOLUTION 2014-63

Approve Purchase 2014 Ford F-250 XLT Crew Cab 4x4

Sponsored By: Councilmember Kaminski, Supervisor Holtz

WHEREAS, The Highway Department has request authorization to purchase of a 2014 Ford F-250 XLT Crew Cab 4x4

WHEREAS, the purchase of the equipment is subject to various NYS laws regarding purchasing of equipment including but not limited to GML Section 103, And

WHEREAS, GML 103 (16) permits the purchase of equipment, etc. through the use of a contract let by a political subdivision of NYS if such political subdivision's contract was let in a manner that constitutes competitive bidding consistent with NYS law and is made available for use by other governmental entities, AND

WHEREAS, as specified in the Chautauqua County DOP, Bid Results Proposal Number E-12-13 PFTH dated November 26, 2013, making its bidding procedures available to other governmental entities in accordance with GML Section 103 (16), AND

WHEREAS, the Cheektowaga Highway Department has reviewed the bidding materials and procedures compiled by the Chautauqua County DOP, and have determined that same are compliant with NYS law including GML 103, NOW THEREFORE BE IT,

RESOLVED, that the Town Board hereby authorizes the purchase of a 2014 Ford F-250 XLT Crew Cab 4x4 in the amount of \$35,154.82 from Van-Bortel Ford, 71 Marsh Road, East Rochester, NY 14445, where funds for said purchase have been budgeted and is available under account number 300-5130-2407.

RESULT:	ADOPTED [UNANIMOUS]
MOVER:	Gerald Kaminski, Councilmember
SECONDER:	Mary Holtz, Supervisor
AYES:	Holtz, Rogowski, Markel, Kaminski, Wozniak, Benczkowski, Meyers



19. RESOLUTION 2014-64

Approve Memberships in Various Organizations for Youth & Recreational Services Department

Sponsored By: Councilmember Wozniak, Councilmember Rogowski

WHEREAS, the Town of Cheektowaga Youth & Recreational Services Department needs to maintain memberships in various organizations in order to effectively operate its programs, and

WHEREAS, the Youth & Recreational Services Department currently maintains memberships in the following organizations/associations:

- ASCAP/ American Society of Composers, Authors & Publishers
- SESAC/Society of European Stage Authors & Composers
- The Association of New York State Youth Bureaus
- Cheektowaga Chamber of Commerce
- National Recreation and Park Association
- NYSPRS/New York State Recreation and Park Society
- WNY Association of Youth Boards
- USA Track and Field
- Metro Buffalo Amateur Softball Association
- WNY Amateur Hockey League
- MNY Midget MOHL
- Ontario Minor Roller Hockey
- US Tennis Association
- Niagara Frontier Recreation and Park Society

and

WHEREAS, the Youth & Recreational Services Department needs to acquire permits from the Erie County Health Department/Commissioner of Finance for the Town pools and other facilities, NOW, THEREFORE, BE IT

RESOLVED, that this Town Board hereby approves membership/organization/permit fees for the above for the Youth & Recreational Services Department and directs that fees for same be paid out of the appropriate department budget line items.

RESULT:	ADOPTED [UNANIMOUS]
MOVER:	Angela M. Wozniak, Councilmember
SECONDER:	James P. Rogowski, Councilmember
AYES:	Holtz, Rogowski, Markel, Kaminski, Wozniak, Benczkowski, Meyers



20. RESOLUTION 2014-65

Abolishment of Administrative Staff Position (Council Office)

Sponsored By: Councilmember Kaminski, Councilmember Markel

WHEREAS, in 2002 the position of Administrative Assistant was created in the Town Council Office to augment the Town Board's support staff; AND

WHEREAS, over the years, due to technological advances, the need for the current level of support staff in the Council Office has declined; THEREFORE, BE IT

RESOLVED, that the position of Administrative Assistant assigned to the Town Council is hereby abolished upon close of business Friday, January 31, 2014; AND, BE IT FURTHER

RESOLVED, that the incumbent of the Administrative Assistant position, upon leaving Town service effective at the close of business Friday, January 31, 2014, will be compensated for the vacation and personal leave time that has been accumulated.

RESULT:	ADOPTED [5 TO 0]
MOVER:	Gerald Kaminski, Councilmember
SECONDER:	Charles Markel, Councilmember
AYES:	Holtz, Markel, Kaminski, Wozniak, Benczkowski
ABSTAIN:	James P. Rogowski, Timothy J. Meyers



21. RESOLUTION 2014-66

Youth & Recreation Terminations

Sponsored By: Councilmember Wozniak, Councilmember Rogowski

BE IT RESOLVED that the individuals listed below be and hereby are terminated in the Department of Youth & Recreational Services effective as indicated:

Nicholas Hawley

7/9/13

14225

Motion by Councilmember Markel; Seconded by Councilmember Rogowski to waive the reading of names for the following three (3) resolutions. Motion carried.

RESULT: **ADOPTED [UNANIMOUS]**

MOVER: Angela M. Wozniak, Councilmember

SECONDER: James P. Rogowski, Councilmember

AYES: Holtz, Rogowski, Markel, Kaminski, Wozniak, Benczkowski, Meyers



22. RESOLUTION 2014-67

Youth & Recreation Hiring

Sponsored By: Councilmember Wozniak, Councilmember Rogowski

BE IT RESOLVED that the individual listed below be and hereby are hired, as indicated, in the Department of Youth & Recreational Services, effective immediately:

Recreation Attendant - 7140.1630 - \$8.25 - Regular Part-time

Mikayla Bluff-Pearce

14225

RESULT:	ADOPTED [UNANIMOUS]
MOVER:	Angela M. Wozniak, Councilmember
SECONDER:	James P. Rogowski, Councilmember
AYES:	Holtz, Rogowski, Markel, Kaminski, Wozniak, Benczkowski, Meyers



23. RESOLUTION 2014-68

Minimum Wage Increase Youth & Recreation Department

Sponsored By: Councilmember Wozniak, Councilmember Rogowski

WHEREAS, the New York State Legislature has approved minimum wage increases in 2014, 2015, and 2016 and

WHEREAS, the first increase becomes effective January 1, 2014, NOW THEREFORE BE IT

RESOLVED that the following individuals be and hereby are elevated as follows so as to comply with the new minimum wage law as it affects the existing workforce pay structure of those earning less than \$8.00 per hour (regular part-time/part-time):

RETRO TO 1/1/14

Shannon Kelly	-	\$8.80
Michael Terranova	-	\$9.00

RESULT:	ADOPTED [UNANIMOUS]
MOVER:	Angela M. Wozniak, Councilmember
SECONDER:	James P. Rogowski, Councilmember
AYES:	Holtz, Rogowski, Markel, Kaminski, Wozniak, Benczkowski, Meyers



24. RESOLUTION 2014-69

Hiring/Amendment of Part-Time Employees

Sponsored By: Councilmember Kaminski, Supervisor Holtz

BE IT RESOLVED, that the following part-time employees' titles be listed after being omitted at the Town Board Meeting of January 6, 2014:

FACILITIES DEPARTMENT (Buildings & Grounds Division) Laborer \$8.25/hour effective 12/23/13

Andrew M. Mays, Cheektowaga, New York

FACILITIES DEPARTMENT (Parks Division) Laborer \$8.25/hour effective 1/7/14

David D. Dankowski, Cheektowaga, New York

Robert J. Bommer III, Cheektowaga, New York

RESULT:	ADOPTED [UNANIMOUS]
MOVER:	Gerald Kaminski, Councilmember
SECONDER:	Mary Holtz, Supervisor
AYES:	Holtz, Rogowski, Markel, Kaminski, Wozniak, Benczkowski, Meyers



25. RESOLUTION 2014-70

Reappointment - Chairperson of Planning Board

Sponsored By: Councilmember Rogowski, Councilmember Meyers

WHEREAS, the term of John Marriott as Chairperson of the Planning Board expired as of December 31, 2013, and

WHEREAS, John Marriott has expressed interest in continuing to serve as Chairperson of the Planning Board, and

WHEREAS, John Marriott has satisfactorily served on the Planning Board and merits reappointment, NOW, THEREFORE, BE IT

RESOLVED, that John Marriott be and hereby is reappointed to the position of Chairperson of the Planning Board, effective January 1, 2014 and terminating on December 31, 2018..

RESULT:	DEFEATED [2 TO 5]
MOVER:	James P. Rogowski, Councilmember
SECONDER:	Timothy J. Meyers, Councilmember
AYES:	James P. Rogowski, Timothy J. Meyers
NAYS:	Holtz, Markel, Kaminski, Wozniak, Benczkowski



26. RESOLUTION 2014-71

Appointment of Clerk (Temporary) Office of the Town Assessor/Amanda J. Murphy

Sponsored By: Councilmember Kaminski, Supervisor Holtz

WHEREAS, a temporary vacancy exists in the position of Clerk in the Office of the Town Assessor; AND

WHEREAS, said vacancy is for no more than ninety (90) days; AND

WHEREAS, there is an immediate need to fill said vacancy; AND

WHEREAS, Amanda J. Murphy, currently a part-time Clerk in the Office of the Town Assessor, meets the necessary qualifications for appointment; NOW, THEREFORE, BE IT

RESOLVED, that Amanda J. Murphy of Cheektowaga, New York, be and hereby is appointed to the temporary position of Clerk in the Office of the Town Assessor in accordance with the terms and conditions of the Town's collective bargaining agreement with the Town of Cheektowaga Employees Association effective January 2, 2014.

RESULT:	ADOPTED [UNANIMOUS]
MOVER:	Gerald Kaminski, Councilmember
SECONDER:	Mary Holtz, Supervisor
AYES:	Holtz, Rogowski, Markel, Kaminski, Wozniak, Benczkowski, Meyers



27. RESOLUTION 2014-72

Travel Authorization Youth & Recreational Services/Youth Leadership Conference

Sponsored By: Councilmember Kaminski, Supervisor Holtz

WHEREAS, the Youth Leadership Conference is being held February 10 through February 11, 2014 in Albany, New York; AND

WHEREAS, Program Coordinator Jillian Gorman-King and Recreation Specialist Melissa Nosal have been recommended to attend said conference; AND

WHEREAS, the Executive Director of Youth and Recreational Services, Ellen Fischer, has submitted a request for travel authorization along with the proper paperwork in a timely manner; AND

WHEREAS, the total cost to the Town shall not exceed \$560; AND

WHEREAS, these expenses have been budgeted by the Department; NOW, THEREFORE, BE IT

RESOLVED, that Program Coordinator Jillian Gorman-King and Recreation Specialist Melissa Nosal be and hereby are authorized to attend the Youth Leadership Conference being held February 10 through February 11, 2014 in Albany, New York

RESULT:	ADOPTED [UNANIMOUS]
MOVER:	Gerald Kaminski, Councilmember
SECONDER:	Mary Holtz, Supervisor
AYES:	Holtz, Rogowski, Markel, Kaminski, Wozniak, Benczkowski, Meyers

V. Suspension of Rules

Motion by Councilmember Rogowski; Seconded by Councilmember Markel to Waive the Rules to Include the following two (2) resolutions: 2014-73 and 2014-74. Motion carried.



1. RESOLUTION 2014-73

Unsecured Limbs/Cayuga Road 92.09-2-39

Sponsored By: Councilmember Markel, Supervisor Holtz

WHEREAS, Town of Cheektowaga Law for the Administration and Enforcement of the Codes of New York State; and the Property Maintenance Code of New York State require that all vacant structures and premises shall be maintained in clean, safe, secure and sanitary conditions so as not to cause a blighting problem or adversely affect the public health or safety and all nuisances abated, AND

WHEREAS, the Town of Cheektowaga has received notification of an unsafe structure and premises located at Cayuga Road, Cheektowaga, New York SBL# 92.09-2-39 that is a danger to the safety of others, and records kept by the Assessors Office identify Phoenix Frontier Inc., 243 Old Lyme Drive, Williamsville, New York 14221, as the owner AND

WHEREAS, an inspection of such premises was conducted at Cayuga Road, by the Housing and Neighborhood Preservation Office, AND

WHEREAS, such inspection found the premises to be deteriorated, vacant, a hazard, and a danger to the safety and well being of others, AND

WHEREAS, the Town of Cheektowaga Housing and Neighborhood Preservation Office properly notified the property owner in accordance with the Town of Cheektowaga Law for the Administration and Enforcement of the Codes of New York State, and the owner failed to take actions to safeguard the premises, AND

WHEREAS, these conditions require the Town of Cheektowaga Housing and Neighborhood Preservation Office to take immediate steps to safeguard the premises to protect the health and safety of others and abate all nuisances, NOW, THEREFORE BE IT

RESOLVED, that pursuant to Section 70-7A.(5) and Section 70-8 of the Town of Cheektowaga Law for the Administration and Enforcement of the Codes of New York State that the vacant structure premises be safeguarded and all nuisances abated; and all costs incurred be assessed against the property hereinbefore described.

RESULT:	ADOPTED [UNANIMOUS]
MOVER:	Charles Markel, Councilmember
SECONDER:	Mary Holtz, Supervisor
AYES:	Holtz, Rogowski, Markel, Kaminski, Wozniak, Benczkowski, Meyers



2. RESOLUTION 2014-74

Unsafe-Unsecured/1574 East Delavan Avenue

Sponsored By: Councilmember Markel, Supervisor Holtz

WHEREAS, Town of Cheektowaga Law for the Administration and Enforcement of the Codes of New York State; and the Property Maintenance Code of New York State require that all vacant structures and premises shall be maintained in clean, safe, secure and sanitary conditions so as not to cause a blighting problem or adversely affect the public health or safety and all nuisances abated, AND

WHEREAS, the Town of Cheektowaga has received notification of an unsafe structure and premises located at 1574 East Delavan Avenue, Cheektowaga, New York SBL# 90.76-2-29 that is a danger to the safety of others, and records kept by the Assessors Office identify Gerald Genson J. Sr., 1574 East Delavan Avenue, Buffalo, New York 14215, as the owner AND

WHEREAS, an inspection of such premises was conducted at 1574 East Delavan Avenue, by the Housing and Neighborhood Preservation Office, AND

WHEREAS, such inspection found the premises to be deteriorated, vacant, a hazard, and a danger to the safety and well being of others, AND

WHEREAS, the Town of Cheektowaga Housing and Neighborhood Preservation Office properly notified the property owner in accordance with the Town of Cheektowaga Law for the Administration and Enforcement of the Codes of New York State, and the owner failed to take actions to safeguard the premises, AND

WHEREAS, these conditions require the Town of Cheektowaga Housing and Neighborhood Preservation Office to take immediate steps to safeguard the premises to protect the health and safety of others and abate all nuisances, NOW, THEREFORE BE IT

RESOLVED, that pursuant to Section 70-7A.(5) and Section 70-8 of the Town of Cheektowaga Law for the Administration and Enforcement of the Codes of New York State that the vacant structure premises be safeguarded and all nuisances abated; and all costs incurred be assessed against the property hereinbefore described.

RESULT:	ADOPTED [UNANIMOUS]
MOVER:	Charles Markel, Councilmember
SECONDER:	Mary Holtz, Supervisor
AYES:	Holtz, Rogowski, Markel, Kaminski, Wozniak, Benczkowski, Meyers

VI. Communications

A. Departmental Communications

1. Minutes: Town Environmental Advisory Committee - December 11, 2013
2. Town of Cheektowaga Emergency Services - Quarterly Report for October to December 2013

B. General Communications

1. Notice of Claim: Joan M Bailey vs. Town of Cheektowaga
2. Notice of Claim: Joan Bucholtz vs. Town of Cheektowaga
3. Notice of Claim: Kenneth Edwards, Jr. vs. Town of Cheektowaga
4. Notice of Claim: Tommy Felder vs. Town of Cheektowaga
5. Notice of Claim: Steven Lauricella vs. Town of Cheektowaga
6. Notice of Claim: Robert J. Meier vs. Town of Cheektowaga
7. Notice of Claim: Niagara Mohawk Power Corp dba National Grid vs. Town of Cheektowaga
8. Notice of Claim: L A Tabolski vs. Town of Cheektowaga
9. Notice of Claim: Cheryl Witt vs. Town of Cheektowaga

VII. Comments

A. Supervisor's Comments

B. Councilmember's Comments

C. Public Comments



Town of Cheektowaga

Work Session

~ Minutes ~

3301 Broadway
Cheektowaga, NY 14227

<http://www.town.cheektowaga.ny.us>

Alice Magierski
716-686-3400

Tuesday, January 28, 2014

6:00 PM

Council Office

I. Call to Order

6:00 PM Meeting called to order on January 28, 2014 at Council Office, Conference Room, Cheektowaga, NY.

Attendee Name	Organization	Title	Status	Arrived
Mary Holtz	Town of Cheektowaga	Supervisor	Present	
James P. Rogowski	Town of Cheektowaga	Councilmember	Present	
Charles Markel	Town of Cheektowaga	Councilmember	Present	
Gerald Kaminski	Town of Cheektowaga	Councilmember	Present	
Angela M. Wozniak	Town of Cheektowaga	Councilmember	Present	
Diane Benczkowski	Town of Cheektowaga	Councilmember	Present	
Timothy J. Meyers	Town of Cheektowaga	Councilmember	Present	

II. Resolution



1. RESOLUTION 2014-75

Abolishment of Clerk of Justice Court Position

Sponsored By: Benczkowski, Kaminski, Holtz, Rogowski, Markel, Wozniak, Meyers

WHEREAS, there are three (3) positions that exist in the Justice Court to provide administrative and management support to the judges; AND

WHEREAS, a work flow study and efficiency assessment was performed by an outside consulting group recommending an adjustment in current administrative and management support staff; AND

WHEREAS, such adjustment includes a reduction in the number of administrative management staff which will reduce the overlapping and inefficient handling of court records and associated paperwork; NOW, THEREFORE, BE IT

RESOLVED, that the position, Clerk of Justice Court, assigned to the Justice Court is hereby abolished upon the close of business February 7, 2014; AND, BE IT FURTHER

RESOLVED, that the incumbent of the Clerk of Justice Court be and hereby is placed on administrative leave with pay from January 29, 2014 through February 7, 2014; AND, BE IT FURTHER

RESOLVED, that upon leaving Town service effective the close of business February 7, 2014, said incumbent will be compensated for accrued leave in accordance with the Town of Cheektowaga Personnel Policy For Exempt Employees That Are Not Department Heads.

RESULT:	ADOPTED [UNANIMOUS]
MOVER:	Diane Benczkowski, Councilmember
SECONDER:	Gerald Kaminski, Councilmember
AYES:	Holtz, Rogowski, Markel, Kaminski, Wozniak, Benczkowski, Meyers



Town of Cheektowaga

Regular Meeting

~ Minutes ~

3301 Broadway
Cheektowaga, NY 14227
<http://www.town.cheektowaga.ny.us>

Alice Magierski
716-686-3400

Monday, February 3, 2014

6:45 PM

Council Chambers

I. Call to Order

6:45 PM Meeting called to order on February 3, 2014 at Council Chambers, 3301 Broadway St, Cheektowaga, NY.

Attendee Name	Organization	Title	Status	Arrived
Mary Holtz	Town of Cheektowaga	Supervisor	Present	
James P. Rogowski	Town of Cheektowaga	Councilmember	Present	
Charles Markel	Town of Cheektowaga	Councilmember	Present	
Gerald Kaminski	Town of Cheektowaga	Councilmember	Present	
Angela M. Wozniak	Town of Cheektowaga	Councilmember	Present	
Diane Benczkowski	Town of Cheektowaga	Councilmember	Present	
Timothy J. Meyers	Town of Cheektowaga	Councilmember	Present	

2. Additional Attendees

Thomas Adamczak, Supervising Building and Plumbing Inspector
Carla A. Kosmerl, Director of Community Development
Brian Krause, Director of Finance and Administration
William Pugh, Town Engineer
Anthony Romano, Coordinator of Employee Relations
Kevin Schenk, Town Attorney
Kerry Switalski, Senior Services Director
David Zack, Chief of Police

II. Public Comment Period

III. Public Hearing

1. Local Law Intro 2014-1 Amend the Zoning Law

COMMENTS - Current Meeting:

This being the time and place advertised for a Public Hearing, the Supervisor directed the Town Clerk to present that such notice has been duly published and posted; upon the order of the Supervisor such proof was duly filed.

The Supervisor announced that the Town Board would hear all persons interested in the subject of the hearing. Comments were heard, after which the Supervisor declared the hearing closed, decision was reserved.

RESULT:	CLOSED [UNANIMOUS]
MOVER:	Charles Markel, Councilmember
SECONDER:	James P. Rogowski, Councilmember
AYES:	Holtz, Rogowski, Markel, Kaminski, Wozniak, Benczkowski, Meyers

IV. Resolutions



1. RESOLUTION 2014-76

Transfer of Funds-2014

Sponsored By: Supervisor Holtz, Councilmember Kaminski

BE IT RESOLVED, that the following transfer is hereby approved and made part hereof;

CDBG

FROM:	700.5099.0799	Village of Depew-Home Safety Program	\$1,725.00
	700.5000.0602	Resident Security Improvements	8,000.00
	700.5000.0751	Resident Security Inspection Program	2,000.00
	700.5001.0602	Resident Security Improvements	10,000.00
	700.5001.0751	Resident Security Inspections	6,000.00
TO:	700.5013.0600	Village of Depew-Housing Rehabilitation- Single Family	\$27,725.00

RESULT:	ADOPTED [UNANIMOUS]
MOVER:	Mary Holtz, Supervisor
SECONDER:	Gerald Kaminski, Councilmember
AYES:	Holtz, Rogowski, Markel, Kaminski, Wozniak, Benczkowski, Meyers



2. RESOLUTION 2014-77

Warrant

Sponsored By: Supervisor Holtz, Councilmember Kaminski

BE IT RESOLVED, that the following Vouchers & Warrants submitted to the Town of Cheektowaga prior to February 3, 2014 are hereby approved and made part hereof;

GENERAL FUND	\$3,686,876.26
RISK RETENTION FUND	1,074,401.15
NYS HOME PROGRAM	
DEBT	24,912.50
HUD HOUSING REHABILITATION FUND	
SPECIAL DISTRICTS FUND	1,405,688.82
HIGHWAY FUND	978,901.96
CAPITAL FUND	13,911.79
TRUST & AGENCY FUND	6,956,559.37
HUD CDBG FUND	7,227.01
PART TOWN FUND	170,689.15
NYS AFFORDABLE HOUSING	
	\$14,319,168.01

RESULT:	ADOPTED [UNANIMOUS]
MOVER:	Mary Holtz, Supervisor
SECONDER:	Gerald Kaminski, Councilmember
AYES:	Holtz, Rogowski, Markel, Kaminski, Wozniak, Benczkowski, Meyers



3. RESOLUTION 2014-78

Adopt Amendments to Vehicle and Traffic Law

Sponsored By: Councilmember Meyers, Councilmember Rogowski

WHEREAS, this Town Board held a public hearing on January 21, 2014 to consider the advisability of adopting proposed amendments to Chapter 235 of the Code of the Town of Cheektowaga (Vehicle and Traffic), said hearing being held in accordance with Notice thereof which was duly published as required by law, at which hearing an opportunity to be heard was afforded all persons interested in the subject thereof,

NOW, THEREFORE, BE IT RESOLVED, as follows:

Section 1.

That this Town Board determines it is in the public interest to adopt the following amendments to Chapter 235 of the Code of the Town of Cheektowaga, County of Erie and State of New York, and said amendments are herewith adopted and enacted:

ARTICLE V. Schedules, Section 235-49, Schedule X: Parking Prohibited in Designated Locations, shall be amended by deleting therefrom the following:

In accordance with the provisions of §235-34, no person shall park a vehicle at any time upon any of the following described streets or parts of streets:

SOUTH CREEK DRIVE - North side: from east curb line of Union Road to west curb line of Nagel Drive

ARTICLE V. Schedules, Section 235-49, Schedule X: Parking Prohibited in Designated Locations, shall be amended by adding thereto the following:

In accordance with the provisions of § 235-34, no person shall park a vehicle at any time upon any of the following described streets or parts of streets:

MARYVALE DRIVE - North side: from the west curb line of Cayuga Road to a point 255 feet west.

TOWN HALL DRIVEWAY IN FRONT OF TOWN HALL - North side: from the east curb line of the Broadway Access Road easterly to the west curb line of the driveway from Broadway

CONSTANCE LANE - East side: from the south curb line of Fairelm Lane to a point 50 feet south.

ARTICLE V. Schedules, Section 235-51, Schedule XII: Stopping Prohibited in Designated Locations, shall be amended by deleting therefrom the following:

DUKE ROAD - West side (north-south leg): from the south curb line of Walden Avenue to the north curb line of Duke Road (east-west leg)

ARTICLE V. Schedules, Section 235-55, Schedule XVI: No Parking Certain Hours, shall be amended to add the following:

TOWN HALL DRIVEWAY IN FRONT OF TOWN HALL - South side: from the east curb line of the Broadway Access Road to the west curb line of the driveway from Broadway - Fifteen (15) minutes only.

ARTICLE V. Schedules, Section 235-46, Schedule VII, Stop Intersections, shall be amended by adding thereto the following:

Stop Signs on	Direction Traffic Stops	At Intersection of
Felber Lane	East	Keicher Road
Burdette Drive	Southwest	Huth Road

Section 2. Time to Take Effect

These amendments shall take effect when properly posted within a reasonable time except those parts, if any, which are subject to approval under Section 1684 of the Vehicle and Traffic Law of the State of New York.

Any part or parts of these amendments which are subject to approval under Section 1684 of the Vehicle and Traffic Law of the State of New York shall take effect from and after the day on which approval in writing is received from the New York State Traffic Commission.

Section 3. Territorial Application

These amendments shall apply to all of the Town of Cheektowaga, Erie County, New York outside of the villages of Depew and Sloan.

Section 4. Publication

That these amendments to Chapter 235 (formerly Chapter 76) of the Code of the Town of Cheektowaga shall be entered into the minutes of the Town Board and shall be published in the CHEEKTOWAGA BEE, a newspaper published in this Town, and affidavits of such publication shall be filed with the Town Clerk and the Town Clerk shall likewise enter in the Ordinance Book a copy of said amendments specifying the date of adoption thereof.

RESULT:	ADOPTED [UNANIMOUS]
MOVER:	Timothy J. Meyers, Councilmember
SECONDER:	James P. Rogowski, Councilmember
AYES:	Holtz, Rogowski, Markel, Kaminski, Wozniak, Benczkowski, Meyers



4. RESOLUTION 2014-79

Negative SEQR Declaration - Part of 1669 Walden Avenue

Sponsored By: Councilmember Meyers, Councilmember Markel

WHEREAS, pursuant to the Environmental Impact Review Ordinance of the Town of Cheektowaga, the Environmental Advisory Committee ("EAC") reviews various applications for site plans, rezonings, special permits, etc. and renders its recommendation concerning the environmental significance of such application, AND

WHEREAS, the Town Board, pursuant to the Environmental Impact Review Ordinance of the Town of Cheektowaga, is designated the Lead Agency in most instances, AND

WHEREAS, since the Town Board is the Lead Agency, it must affirm, modify or reject any recommendations submitted to it by the Advisory Committee, AND

WHEREAS, an application was submitted by Benderson Development Co., LLC for the construction rezoning of a part of 1669 Walden Avenue from CM- General Commercial to MS- Motor Services for the construction of a 15,000 s.f. motor vehicle repair facility with collision services, AND

WHEREAS, the Environmental Advisory Committee at its meetings held on January 8, 2014 recommended a determination of non-significance as shown on the attached memorandum dated January 8, 2014, AND

WHEREAS, the Town of Cheektowaga Planning Board recommended approval of the site plan at their meeting of January 9, 2014, AND

WHEREAS, this Town Board has reviewed the application submitted and the recommendations made by the Environmental Advisory Committee and the Planning Board NOW, THEREFORE, BE IT

RESOLVED, that this Town Board determines that the project will not have a significant effect on the environment and therefore issues a Negative Declaration for purposes of the State Environmental Quality Review Act (SEQRA).

RESULT:	ADOPTED [UNANIMOUS]
MOVER:	Timothy J. Meyers, Councilmember
SECONDER:	Charles Markel, Councilmember
AYES:	Holtz, Rogowski, Markel, Kaminski, Wozniak, Benczkowski, Meyers



5. RESOLUTION 2014-80

Accept Site Plan- Part of 1669 Walden Avenue

Sponsored By: Councilmember Markel, Councilmember Rogowski

WHEREAS, pursuant to the Zoning Law of the Town of Cheektowaga, the Planning Board reviews various development review applications for site plans, rezonings, special permits and realty subdivisions and renders its recommendation concerning the compatibility of such application with the zoning regulations, the Town Master Plan and neighborhood character, AND

WHEREAS, the Town Board, pursuant to section 260-47.1C of the Zoning Law of the Town of Cheektowaga is vested with the authority to approve site plans and modify or reject any recommendation submitted to it by its advisory committees, AND

WHEREAS, Benderson Development Co., LLC submitted a development review application for the construction of a 15,000 s.f. motor repair facility at 1669 Walden Avenue, AND

WHEREAS, the Town of Cheektowaga Planning Board, reviewed and commented on the Application at their meeting of January 9, 2014 and have recommended approval thereof, NOW THEREFORE BE IT,

RESOLVED, that pursuant to Section 260-47-1 of the Code of the Town of Cheektowaga and Section 274-a of New York State Town Law that this Town Board approves the proposed site plan subject to:

1. The Town Engineer reviewing and approving the drainage/grading plan.
2. The Applicant installing a public sidewalk along his /her frontage along Dale Road. Said walk shall be installed upon the completion of a public walk connection by the adjacent land owner to the east.

Attachments:

site plan (PDF)

Architectural Character (PDF)

RESULT:	ADOPTED [UNANIMOUS]
MOVER:	Charles Markel, Councilmember
SECONDER:	James P. Rogowski, Councilmember
AYES:	Holtz, Rogowski, Markel, Kaminski, Wozniak, Benczkowski, Meyers



6. RESOLUTION 2014-81

Approval of Rezoning of a Portion of 1669 Walden Avenue

Sponsored By: Councilmember Markel, Councilmember Meyers

WHEREAS, Benderson Development Co., LLC petitioned for a rezoning from CM-General Commercial District to MS-Motor Services District for property owned by it and identified as a portion of 1669 Walden Avenue, Cheektowaga, New York, which property is described in the attached legal description, for the construction of a vehicle repair facility with collision services, and

WHEREAS, a public hearing on such petition was held before this Town Board on the 18th day of November, 2013 at 6:45 P.M., after publication and service of the notices required by the provisions of the Code of the Town of Cheektowaga ("Zoning Law"), and the Town Law; and all interested parties were given an opportunity to be heard at such hearing, and

WHEREAS, the Cheektowaga Planning Board has reviewed such application and has recommended approval thereof, and

WHEREAS, this Town Board previously issued a Negative Declaration under SEQRA and the Town Environmental Impact Review Ordinance for this rezoning, NOW, THEREFORE, BE IT

RESOLVED, that the application of Benderson Development Co., LLC for the rezoning from CM-General Commercial District to MS-Motor Services District of the property described in the attached legal description for the construction of a vehicle repair facility with collision services be and the same is hereby approved, and BE IT FURTHER

RESOLVED, that any future additions to the development or site plan must be resubmitted to the Town Board to determine whether the addition is substantially in agreement with the intent of this rezoning and site plan approval, and BE IT FURTHER

RESOLVED, that the Zoning Map and Law of the Town Of Cheektowaga be amended in accordance with the above.

LEGAL DESCRIPTION

All that tract or parcel of land situate in the Town of Cheektowaga, County of Erie and State of New York, being part of Lot No. 24, Township 11, Range 7 of the Holland Land Company's Survey, described as follows;

Commencing at a point in the northerly line of Dale Road at the intersection of the said northerly line of Dale Road and the Easterly line of map cover 372, thence easterly along said northerly line of Dale road a distance of one hundred eighty and fifty-six hundredths feet (180.56') to the point or place of beginning;

Thence continuing easterly along said northerly line of Dale road a distance of two

hundred thirty-one and fourteen hundredths feet (231.14') to a point in the easterly line of Randall Benderson 1993-1 Trust by Liber 10904 and Page 8690;

Thence northerly and forming an interior angle of 71°58'27" and along said easterly line of Randall Benderson 1993-1 trust a distance of two hundred thirty-six and forty-nine hundredths feet (236.49') to a point;

Thence westerly forming an interior angle of 91°32'52" a distance of two hundred nineteen and eighty-five hundredths feet (219.85') to a point;

Thence southerly forming an interior angle of 88°27'29" a distance of one hundred seventy and ninety hundredths feet (170.90') to the point or place of beginning. Containing 1.03 acres of land more or less.

RESULT:	ADOPTED [UNANIMOUS]
MOVER:	Charles Markel, Councilmember
SECONDER:	Timothy J. Meyers, Councilmember
AYES:	Holtz, Rogowski, Markel, Kaminski, Wozniak, Benczkowski, Meyers



7. RESOLUTION 2014-82

Award of Bid - Baseball & Softball (Bid 2014-2)

Sponsored By: Councilmember Wozniak, Councilmember Rogowski

WHEREAS, sealed bids were duly received by the Town Board at a bid opening (Bid # 2014-2) on January 22, 2014 for the furnishing of baseball and softball equipment as a result of advertising thereof, and such bids were referred to the Department of Youth & Recreational Services for analysis, tabulation and report, and

WHEREAS, such analysis, tabulation and report have been completed, BE IT

RESOLVED that bids be awarded to the lowest responsible bidder meeting specifications, and to be in the best interest of the Town of Cheektowaga for the calendar year February 2014 - February 2015:

Jim Ludtka Sporting Goods
2500 Walden Avenue
Cheektowaga, New York 14225

Laux Sporting Goods Inc
25 Pineview Drive
Amherst, New York 14228

Anaconda Sports
85 Katrine Lane
Lake Katrine, NY 12449

BE IT FURTHER RESOLVED that the costs resulting from the awarding of this bid are funded through 7140; 7180 and 7310 accounts for cost centering purposes.

RESULT:	ADOPTED [UNANIMOUS]
MOVER:	Angela M. Wozniak, Councilmember
SECONDER:	James P. Rogowski, Councilmember
AYES:	Holtz, Rogowski, Markel, Wozniak, Benczkowski, Meyers
ABSENT:	Gerald Kaminski



8. RESOLUTION 2014-83

Notice to Bidders - Work Uniforms (Bid #2014-7)

Sponsored By: Supervisor Holtz, Councilmember Meyers

WHEREAS, it is in order that bids be advertised for the purchase of Work Uniforms for the year of 2014 for the Town of Cheektowaga (Bid 2014-7), AND

WHEREAS, the Engineering Department has prepared specifications for same, NOW, THEREFORE, BE IT

RESOLVED, that the Town Clerk be directed to publish a Notice to Bidders for the furnishing of Work Uniforms to the Town of Cheektowaga for the year of 2014, said notice to be published in the CHEEKTOWAGA BEE, AND, BE IT FURTHER

RESOLVED, that sealed bids will be received on the 19th day of February, 2014 at 11:00 am at a public bid opening to be held in the Council Chambers in the Cheektowaga Town Hall.



NOTICE TO BIDDERS

Sealed proposals will be received and considered by the Town Board of the Town of Cheektowaga on February 19, 2014 at 11:00 am at the Town Hall, corner of Broadway and Union Roads, for the furnishing of Work Uniforms for the 2014 calendar year (Bid 2014-7).

Information for bidders and specifications may be obtained from the Town Clerk at her office in said Town.

The Town Board reserves the right to consider informal any bid not prepared and submitted in accordance with the provisions of the specifications and contract documents and may waive any informalities, make an award to other than the low bidder, should it be in the best interest of the Town, or reject any and all bids.

By order of the Town Board of the Town of Cheektowaga, Erie County, New York.

Alice Magierski, Town Clerk

DATED: February 3, 2014

RESULT:	ADOPTED [UNANIMOUS]
MOVER:	Mary Holtz, Supervisor
SECONDER:	Timothy J. Meyers, Councilmember
AYES:	Holtz, Rogowski, Markel, Wozniak, Benczkowski, Meyers
ABSENT:	Gerald Kaminski



9. RESOLUTION 2014-84

Notice to Bidders - 2014 Chevrolet Tahoe Vehicles for Police Department (Bid 2014-08)

Sponsored By: Councilmember Benczkowski, Councilmember Kaminski

BE IT RESOLVED, that the Town Clerk is hereby directed to publish a Notice to Bidders for the for the purchase of Two (2) New and Unused 2014 or newer Chevrolet Tahoe 4WD 4-door LS Vehicles (or Equivalent), for the Cheektowaga Police Department (Bid 2014-8); and BE IT FURTHER

RESOLVED, that sealed bids will be received by the Town Clerk on the 12th day of February, 2014 at 11:00 A.M., at a public bid opening to be held in the Council Chambers in the Cheektowaga Town Hall, 3301 Broadway, Cheektowaga, New York, 14227.



NOTICE TO BIDDERS (BID 2014-08 PD)

Sealed proposals will be received and opened by the Town Clerk of the Town of Cheektowaga on Wednesday, February 12, 2014 at 11:00 A.M. in the Council Chambers, First Floor, Cheektowaga Town Hall, 3301 Broadway, Cheektowaga, New York, for the purchase of Two (2) New and Unused 2014 or newer Chevrolet Tahoe 4WD 4-door LS Vehicles (or Equivalent), for the Cheektowaga Police Department (Bid 2014-8) as specified.

Information for bidders and specifications may be obtained from the Town Clerk at her office in said Town. One bid is to be submitted for the purchase Two (2) New and Unused 2014 or newer Chevrolet Tahoe 4WD 4-door LS Vehicles (or Equivalent), as listed in the Bid Specifications.

The Town Board reserves the right to consider informal any bid not prepared and submitted in accordance with the provisions of the specifications and contract documents, and may waive any informalities, make an award to other than the low bidder should it be in the best interest of the Town, or reject any or all bids.

By order of the Town Board of the Town of Cheektowaga, Erie County, New York.

Alice Magierski, Town Clerk

Dated: February 3, 2014

RESULT:	ADOPTED [UNANIMOUS]
MOVER:	Diane Benczkowski, Councilmember
SECONDER:	Timothy J. Meyers, Councilmember
AYES:	Holtz, Rogowski, Markel, Wozniak, Benczkowski, Meyers
ABSENT:	Gerald Kaminski



10. RESOLUTION 2014-85

Notice to Bidders - Street Light Standards (Bid # 2014-9)

Sponsored By: Councilmember Kaminski, Supervisor Holtz

WHEREAS, it is in order that bids be advertised for the purchase of round tapered aluminum street light standards with tapered elliptical arms (Bid 2014-9), AND

WHEREAS, the Engineering Department has prepared specifications for same, NOW, THEREFORE, BE IT

RESOLVED, that the Town Clerk be directed to publish a Notice to Bidders for the furnishing of round tapered aluminum street light standards with tapered elliptical arms, said notice to be published in THE CHEEKTOWAGA BEE, AND, BE IT FURTHER

RESOLVED, that sealed bids will be received on the 19th day of February, 2014 at 11:00 am, at a public bid opening to be held in the Council Chambers at the Cheektowaga Town Hall.



NOTICE TO BIDDERS

Sealed proposals will be received and considered by the Town Board of the Town of Cheektowaga on February 19, 2014 at 11:00 am, at the Town Hall, corner of Broadway and Union Roads, for the furnishing of round tapered aluminum street light standards and tapered elliptical arms for the Town Sign Maintenance Division of the Highway Department (Bid 2014-9).

Information for bidders and specifications may be obtained from the Office of the Town Clerk in Town Hall.

The Town Board reserves the right to consider informal any bid not prepared and submitted in accordance with the provisions of the specifications and contract documents, and may waive any informalities, make an award to other than the low bidder, should it be in the best interest of the Town, or reject any and all bids.

By order of the Town Board of the Town of Cheektowaga, Erie County, New York.

Alice Magierski, Town Clerk

DATED: February 3, 2014

RESULT: **ADOPTED [UNANIMOUS]**
MOVER: Mary Holtz, Supervisor
SECONDER: James P. Rogowski, Councilmember
AYES: Holtz, Rogowski, Markel, Wozniak, Benczkowski, Meyers
ABSENT: Gerald Kaminski



11. RESOLUTION 2014-86

Call for Public Hearing for Rezoning - SBL 114.04-5-27.1

Sponsored By: Councilmember Markel, Councilmember Rogowski

WHEREAS, 4968 Transit Road, LLC has made application and requested the rezoning of vacant land along Transit Road, north of 4968 Transit Road, identified as SBL No. 114.04-5-27.1 from NS- Neighborhood Services to C- Retail Business and MS- Motor Services to permit the construction of a 19,800 s.f. retail building and a 6,258 s.f. motor repair facility building, NOW, THEREFORE BE IT

RESOLVED, that a Public Hearing be held regarding said request under the provisions of the Zoning Law on February 19, 2014 at 6:45 P.M., at the Cheektowaga Town Hall, 3301 Broadway at the corner of Union Road.



Notice of Public Hearing

NOTICE IS HEREBY GIVEN that a Public Hearing will be held by the Town Board of the Town of Cheektowaga, Erie County, New York at the Town Hall in the said Town of Cheektowaga, 3301 Broadway corner of Union Road on the 19th day of February, 2014 at 6:45 P.M., of said day for the purpose of considering the application of:

4968 Transit Road, LLC

for the rezoning of of vacant land along Transit Road, north of 4968 Transit Road, identified as SBL No. 114.04-5-27.1 from NS- Neighborhood Services to C- Retail Business and MS- Motor Services to permit the construction of a 19,800 s.f. retail building and a 6,258 s.f. motor repair facility building

All parties in interest and citizens will be given an opportunity to be heard in regard to such proposed application.



LEGAL DESCRIPTION

ALL THAT TRACT OR PARCEL OF LAND, situate in the Town of Cheektowaga, County of Erie and State of New York, being part of Lot No, 46, Township 10, Range 7 of the Buffalo Creek Reservation, bounded and described as follows:

Beginning at the point of intersection of the south line of Strasmer Road (66 feet wide) with the line of Transit Road (1 00 feet wide); running thence south along said west line of Transit Road, 400 feet to the principal point or place of beginning, said point of beginning also being the

southeast corner of lands conveyed to NY Chiropractic College by deed recorded in the Erie County Clerk's Office in Liber 10945 of Deeds at page 5613; thence south and continuing along said west line of Transit Road, a distance of 353.64 feet more or less to the northeast corner of lands conveyed to Pay A. Josefiak and Pearl A. his wife by deed recorded in the Erie County Clerk's Office in Liber 3684 of Deeds at page 218; thence west along said Josefiak's north line a distance of 383 feet to a point in the east line of lands conveyed to Ludwig Zellner and Grace his wife by deed recorded in the Erie County Clerk's Office in Liber 3243 of Deeds at page 161; thence north along said Zellner's east line, a distance of 359.46 feet more or less to the southwest corner of lands conveyed to NY Chiropractic College by deed first above mentioned; thence east along said NY Chiropractic College's south line, a distance of 383 feet to the point of beginning.

RESULT:	ADOPTED [UNANIMOUS]
MOVER:	Charles Markel, Councilmember
SECONDER:	James P. Rogowski, Councilmember
AYES:	Holtz, Rogowski, Markel, Kaminski, Wozniak, Benczkowski, Meyers



12. RESOLUTION 2014-87

Notice of Hearing for Demolition of 42 Avery Place

Sponsored By: Councilmember Markel, Supervisor Holtz

WHEREAS, the Supervising Code Enforcement Officer has received information that the building located at 42 Avery Place in the Town of Cheektowaga (S.B.L. No. 101.28-11-21) has become dangerous and unsafe to the general public and unfit for the purposes for which it may lawfully be used; and

WHEREAS, said building has been inspected and a written report of the condition has been completed by Nussbaumer & Clarke, Inc., duly authorized agent of the Town of Cheektowaga, setting forth its findings and recommendations in regard to the repair or demolition and removal of the building, and said written report describes extensive deterioration and damage to the building and premises and recommends that the building be demolished and removed; and

WHEREAS, the Town Board has fully considered such written report and has determined that the building is dangerous and unsafe to the general public and unfit for the purposes for which it may lawfully be used; NOW THEREFORE BE IT

RESOLVED, that this Town Board accepts the findings and recommendations of Nussbaumer & Clarke, Inc., dated November 6, 2013; and BE IT FURTHER

RESOLVED, that a notice shall be served, pursuant to Section 75-7 of the Cheektowaga Town Code, upon the owner, executor, administrator, agent, lessee or any person having a vested or contingent interest in such unsafe building as shown by the records of the Receiver of Taxes or of the County Clerk, which notice shall have the contents prescribed by Section 75-6 of said Town Code, including, but not limited to, a date, time and place for a hearing before the Town Board in relation to such dangerous and unsafe building, which hearing shall be scheduled not less than five business days from the date of service of the notice, and BE IT FURTHER

RESOLVED, that a hearing before this Board in relation to this dangerous and unsafe building shall be held on the 19th day of February, 2014, at 6:45 P.M. at the Cheektowaga Town Hall, 3301 Broadway, Cheektowaga, New York, and BE IT FURTHER

RESOLVED, that the Code Enforcement Office and/or the Town Attorney's Office be and hereby are directed to serve notice of said hearing on all interested parties.

RESULT:	ADOPTED [UNANIMOUS]
MOVER:	Charles Markel, Councilmember
SECONDER:	Mary Holtz, Supervisor
AYES:	Holtz, Rogowski, Markel, Kaminski, Wozniak, Benczkowski, Meyers



13. RESOLUTION 2014-88

Authorize Supervisor to Execute State Archives Grant Application

Sponsored By: Supervisor Holtz, Councilmember Benczkowski

WHEREAS, the Town of Cheektowaga seeks grant monies from New York State Education Department State Archives Local Government Records Management Improvement Fund to improve management of electronic records, and THEREFORE BE IT

RESOLVED, that Lisa Bolognese, the Town's Record Manager, be authorized and directed to complete the necessary application, forms, etc. to be submitted to the New York State Education Department State Archives for the purpose of securing this grant, and BE IT FURTHER

RESOLVED, that the Supervisor and Town Clerk be and hereby are authorized and directed to execute all documents pertaining to the application and acquisition of said funding.

RESULT:	ADOPTED [UNANIMOUS]
MOVER:	Mary Holtz, Supervisor
SECONDER:	Diane Benczkowski, Councilmember
AYES:	Holtz, Rogowski, Markel, Kaminski, Wozniak, Benczkowski, Meyers



14. RESOLUTION 2014-89

Authorize Supervisor to Execute Music License Agreement

Sponsored By: Councilmember Wozniak, Supervisor Holtz

WHEREAS, the Town uses thousands of copyrighted musical works at Town sponsored festivals, concerts, parades, parks, swimming pools, ice rinks, Senior Center activities and other events; and

WHEREAS, rather than obtaining permission to perform music from individual copyright holders, it is more cost-effective for the Town to obtain a blanket license agreement granting the Town permission to perform such copyrighted musical works in compliance with applicable law; and

WHEREAS, BMI, Inc., ("BMI") representing thousands of songwriters, lyricists, and music publishers, has offered a blanket license agreement to the Town that will authorize the performance of all copyrighted musical compositions in their repertoire for a license fee of \$783.00, with annual rate adjustments in accordance with any percentage increase in the Consumer Price Index-All Urban Consumers (CPI-U), as more fully detailed in the license agreement; and

WHEREAS, the Town Attorney recommends that the Town enter into this Agreement with BMI; NOW, THEREFORE, BE IT

RESOLVED, that the Supervisor be and hereby is authorized and directed to execute a License Agreement with BMI, subject to approval by the Town Attorney's Office; and BE IT FURTHER

FURTHER RESOLVED, that any fees associated with said license shall be appropriated from account number 100-7310-4601.

RESULT:	ADOPTED [UNANIMOUS]
MOVER:	Angela M. Wozniak, Councilmember
SECONDER:	Mary Holtz, Supervisor
AYES:	Holtz, Rogowski, Markel, Kaminski, Wozniak, Benczkowski, Meyers



15. RESOLUTION 2014-90

Authorize Agreement with Bluenail Management Solutions

Sponsored By: Councilmember Benczkowski, Councilmember Kaminski

WHEREAS, the Town of Cheektowaga Police Department ("Police Department") is interested in retaining an individual or company to provide Microsoft SharePoint and Access Database Programming and Microsoft SharePoint and Access Database Training (hereinafter referred to as "Programming and Training"); and

WHEREAS, Bluenail Management Solutions, LLC ("Bluenail") has the expertise and qualifications to program and train personnel to efficiently utilize its custom built Microsoft SharePoint and Access Database; and

WHEREAS, the Police Department interviewed Joseph Sabol of Bluenail and is confident that Bluenail can program and train personnel of the Police Department and,

WHEREAS, an agreement between the Town and Bluenail has been reviewed by the Town Attorney; NOW, THEREFORE, BE IT

RESOLVED, that the Supervisor be and hereby is authorized and directed to execute said agreement with Bluenail; and BE IT FURTHER

RESOLVED, that funding for the services to be provided shall be appropriated from budget line item number 0100-3120-4321.

RESULT:	ADOPTED [UNANIMOUS]
MOVER:	Diane Benczkowski, Councilmember
SECONDER:	Gerald Kaminski, Councilmember
AYES:	Holtz, Rogowski, Markel, Kaminski, Wozniak, Benczkowski, Meyers



16. RESOLUTION 2014-91

Unsafe Tree Limbs/13 Donlen Drive

Sponsored By: Councilmember Markel, Supervisor Holtz

WHEREAS, Town of Cheektowaga Law for the Administration and Enforcement of the Codes of New York State; and the Property Maintenance Code of New York State require that all vacant structures and premises shall be maintained in clean, safe, secure and sanitary conditions so as not to cause a blighting problem or adversely affect the public health or safety and all nuisances abated, AND

WHEREAS, the Town of Cheektowaga has received notification of an unsafe structure and premises located at 13 Donlen Drive, Cheektowaga, New York SBL# 91.14-9-46 that is a danger to the safety of others, and records kept by the Assessors Office identify Donald Stoklosa and Wife, 8243 Katie Lane, Williamsville, New York 14221, as the owner AND

WHEREAS, an inspection of such premises was conducted at 13 Donlen Drive, by the Housing and Neighborhood Preservation Office, AND

WHEREAS, such inspection found the premises to be deteriorated, vacant, a hazard, and a danger to the safety and well being of others, AND

WHEREAS, the Town of Cheektowaga Housing and Neighborhood Preservation Office properly notified the property owner in accordance with the Town of Cheektowaga Law for the Administration and Enforcement of the Codes of New York State, and the owner failed to take actions to safeguard the premises, AND

WHEREAS, these conditions require the Town of Cheektowaga Housing and Neighborhood Preservation Office to take immediate steps to safeguard the premises to protect the health and safety of others and abate all nuisances, NOW, THEREFORE BE IT

RESOLVED, that pursuant to Section 70-7A.(5) and Section 70-8 of the Town of Cheektowaga Law for the Administration and Enforcement of the Codes of New York State that the vacant structure premises be safeguarded and all nuisances abated; and all costs incurred be assessed against the property hereinbefore described.

RESULT:	ADOPTED [UNANIMOUS]
MOVER:	Charles Markel, Councilmember
SECONDER:	Mary Holtz, Supervisor
AYES:	Holtz, Rogowski, Markel, Kaminski, Wozniak, Benczkowski, Meyers



17. RESOLUTION 2014-92

Unsafe-Unsecured/16A-D Glenwood

Sponsored By: Councilmember Markel, Supervisor Holtz

WHEREAS, Town of Cheektowaga Law for the Administration and Enforcement of the Codes of New York State; and the Property Maintenance Code of New York State require that all vacant structures and premises shall be maintained in clean, safe, secure and sanitary conditions so as not to cause a blighting problem or adversely affect the public health or safety and all nuisances abated, AND

WHEREAS, the Town of Cheektowaga has received notification of an unsafe structure and premises located at 16A-D Glenwood Court, Cheektowaga, New York SBL# 91.15-1-15 that is a danger to the safety of others, and records kept by the Assessors Office identify Louis Migliore, 1034 Amherst Street, Buffalo, New York 14216, as the owner AND

WHEREAS, an inspection of such premises was conducted at 16A-D Glenwood Court, by the Housing and Neighborhood Preservation Office, AND

WHEREAS, such inspection found the premises to be deteriorated, vacant, a hazard, and a danger to the safety and well being of others, AND

WHEREAS, the Town of Cheektowaga Housing and Neighborhood Preservation Office properly notified the property owner in accordance with the Town of Cheektowaga Law for the Administration and Enforcement of the Codes of New York State, and the owner failed to take actions to safeguard the premises, AND

WHEREAS, these conditions require the Town of Cheektowaga Housing and Neighborhood Preservation Office to take immediate steps to safeguard the premises to protect the health and safety of others and abate all nuisances, NOW, THEREFORE BE IT

RESOLVED, that pursuant to Section 70-7A.(5) and Section 70-8 of the Town of Cheektowaga Law for the Administration and Enforcement of the Codes of New York State that the vacant structure premises be safeguarded and all nuisances abated; and all costs incurred be assessed against the property hereinbefore described.

RESULT:	ADOPTED [UNANIMOUS]
MOVER:	Charles Markel, Councilmember
SECONDER:	Mary Holtz, Supervisor
AYES:	Holtz, Rogowski, Markel, Kaminski, Wozniak, Benczkowski, Meyers



18. RESOLUTION 2014-93

Youth & Recreation Hiring

Sponsored By: Councilmember Wozniak, Councilmember Rogowski

BE IT RESOLVED that the individuals listed below be and hereby are hired, as indicated, in the Department of Youth & Recreational Services, effective as indicated:

Effective immediately

Recreation Aide - 7140.1630 - \$8.00 - Part-time

Verliddia Jones 14211

Retro to 1/22/14

Lifeguard "Level I" - 7180.1903 - \$9.00 - Regular Part-time

Jacob Radlich 14225

RESULT:	ADOPTED [UNANIMOUS]
MOVER:	Angela M. Wozniak, Councilmember
SECONDER:	James P. Rogowski, Councilmember
AYES:	Holtz, Rogowski, Markel, Kaminski, Wozniak, Benczkowski, Meyers



19. RESOLUTION 2014-94

Hiring/Termination of Part Time/Seasonal Employees

Sponsored By: Councilmember Kaminski, Supervisor Holtz

BE IT RESOLVED, that the following individuals be and hereby are hired as **PART-TIME EMPLOYEES** in the departments listed, not to exceed nineteen (19) hours on a weekly basis, in compliance with Civil Service Laws and Regulations as well as the provisions of the Town's collective bargaining agreement between the Town of Cheektowaga and the Town of Cheektowaga Employees Association:

POLICE DEPARTMENT School Crossing Guard \$9.75/hour effective 1/22/14
Patricia H. Cwiklinski, Cheektowaga, New York

SENIOR SERVICES Van Driver \$9.25/hour effective 2/3/14
Eugene J. Wrotecki, Cheektowaga, New York

BE IT RESOLVED, that the following seasonal and/or part-time employees be and hereby are terminated as listed:

SANITATION DEPARTMENT
Patricia J. Krzemien effective 5/26/12

OFFICE OF THE TOWN ASSESSOR
Mariesa R. Almorabi effective 9/11/13

SANITATION DEPARTMENT
Brandon Ashraf effective 1/27/14

FACILITIES DEPARTMENT
David D. Dankowski effective 1/18/14
Tyler M. Pocobello effective 12/3/13
John E. Gluszek effective 9/13/13
Karol J. Szymczuk effective 12/2/13
Mark D. Superczynski effective 11/2/13

RESULT:	ADOPTED [UNANIMOUS]
MOVER:	Gerald Kaminski, Councilmember
SECONDER:	Mary Holtz, Supervisor
AYES:	Holtz, Rogowski, Markel, Kaminski, Wozniak, Benczkowski, Meyers



20. RESOLUTION 2014-95

Authorization of Student Interns (Police Department)/Derek J. Accurso, Alexis C. Clune and Ashley M. Becker

Sponsored By: Councilmember Kaminski, Supervisor Holtz

WHEREAS, Ashley M. Becker, a student at Bryant & Stratton College, Derek J. Accurso and Alexis C. Clune, students at Hilbert College, have requested to participate in the student internship program at the Police Department; AND

WHEREAS, these individuals have been interviewed by the Police Department and the Police Department is willing to afford them the opportunity to intern in the Police Department; NOW, THEREFORE, BE IT

RESOLVED, that Ashley M. Becker of West Seneca, New York, Derek J. Accurso of Elma, New York, and Alexis C. Clune of Tonawanda, New York, be and hereby are authorized to participate as unpaid interns in the Police Department, subject to their execution of a Waiver of Liability and Agreement of Confidentiality; AND, BE IT FURTHER

RESOLVED, that Ms. Becker's, Mr. Accurso's and Ms. Clune's internships be and hereby are effective January 1, 2014 through May 31, 2014; AND, BE IT FURTHER

RESOLVED, that the Supervisor be and hereby is authorized and directed to execute the Agreement of Confidentiality, and all other documents necessary to effectuate these student internships in the Police Department.

RESULT:	ADOPTED [UNANIMOUS]
MOVER:	Gerald Kaminski, Councilmember
SECONDER:	Mary Holtz, Supervisor
AYES:	Holtz, Rogowski, Markel, Kaminski, Wozniak, Benczkowski, Meyers



21. RESOLUTION 2014-96

Authorization of Student Intern (Justice Court)/Lynn Imiola

Sponsored By: Councilmember Kaminski, Supervisor Holtz

WHEREAS, Lynn Imiola, a student at Bryant & Stratton College, has requested to participate in the student internship program at the Justice Court; AND

WHEREAS, this individual has been interviewed by the Justice Court and the Justice Court is willing to afford her the opportunity to intern in the Justice Court; NOW, THEREFORE, BE IT

RESOLVED, that Lynn Imiola of Cheektowaga, New York, be and hereby is authorized to participate as an unpaid intern in the Justice Court, subject to her execution of a Waiver of Liability and Agreement of Confidentiality; AND, BE IT FURTHER

RESOLVED, that Ms. Imiola's internship be and hereby is effective January 1, 2014 through May 31, 2014; AND, BE IT FURTHER

RESOLVED, that the Supervisor be and hereby is authorized and directed to execute the Agreement of Confidentiality, and all other documents necessary to effectuate this student internship in the Justice Court.

RESULT:	ADOPTED [UNANIMOUS]
MOVER:	Gerald Kaminski, Councilmember
SECONDER:	Mary Holtz, Supervisor
AYES:	Holtz, Rogowski, Markel, Kaminski, Wozniak, Benczkowski, Meyers



22. RESOLUTION 2014-97

Transfer of Motor Equipment Operator - B to Laborer - Highway Department (Roy W. Baer, Jr.)

Sponsored By: Councilmember Kaminski, Supervisor Holtz

BE IT RESOLVED, that Roy W. Baer, Jr. be and hereby is transferred from the position of Motor Equipment Operator - B to the position of Laborer in the Highway Department effective January 16, 2014.

RESULT:	ADOPTED [UNANIMOUS]
MOVER:	Gerald Kaminski, Councilmember
SECONDER:	Mary Holtz, Supervisor
AYES:	Holtz, Rogowski, Markel, Kaminski, Wozniak, Benczkowski, Meyers



23. RESOLUTION 2014-98

Reappointment of Library Board Member

Sponsored By: Councilmember Wozniak, Councilmember Rogowski

WHEREAS, the term of Judith Mietlicki as Member of the Cheektowaga Public Library Board expires on December 31, 2013, and

WHEREAS, Judith Mietlicki has requested reappointment to the Cheektowaga Library Board, and

WHEREAS, the Cheektowaga Library Board has recommended that Judith Mietlicki be reappointed as member of the Cheektowaga Library Board, NOW, THEREFORE, BE IT

RESOLVED, that Judith Mietlicki, of Cheektowaga, New York be and hereby is reappointed to the position of Member of the Cheektowaga Public Library Board, effective January 1, 2014 and terminating on December 31, 2018.

RESULT:	ADOPTED [UNANIMOUS]
MOVER:	Angela M. Wozniak, Councilmember
SECONDER:	James P. Rogowski, Councilmember
AYES:	Holtz, Rogowski, Markel, Kaminski, Wozniak, Benczkowski, Meyers



24. RESOLUTION 2014-99

Appointment of Planning Board Chairman

Sponsored By: Councilmember Markel, Councilmember Kaminski

WHEREAS, the term of the Chairman of the Planning Board expired as of December 31, 2013, and

WHEREAS, Stanley J. Kaznowski III has expressed an interest in serving as Chairman of the Planning Board, and

WHEREAS, Stanley J. Kaznowski III meets the qualifications for said position and merits appointment, NOW, THEREFORE, BE IT

RESOLVED, that Stanley J. Kaznowski III, of Cheektowaga, New York be and hereby is appointed to the position of Chairman of the Planning Board, effective immediately and terminating on December 31, 2018.

RESULT:	TABLED [UNANIMOUS] Next: 2/19/2014 6:45 PM
MOVER:	James P. Rogowski, Councilmember
SECONDER:	Timothy J. Meyers, Councilmember
AYES:	Holtz, Rogowski, Markel, Kaminski, Wozniak, Benczkowski, Meyers



25. RESOLUTION 2014-100

Appointment of Assistant Police Chief (Competitive/Permanent)/James J. Speyer Jr.

Sponsored By: Councilmember Kaminski, Supervisor Holtz

WHEREAS, a vacancy exists in the title of Assistant Police Chief in the Police Department; AND

WHEREAS, said job title is in the competitive class of civil service; AND

WHEREAS, an interview was conducted and work performance reviews studied; AND

WHEREAS, James J. Speyer, Jr., currently employed as a Police Captain in the Police Department, appears on the existing civil service list and meets the necessary qualifications for appointment; NOW, THEREFORE, BE IT

RESOLVED, that Police Captain James J. Speyer, Jr., of Depew, New York, be and hereby is appointed to the position of Assistant Police Chief in the Police Department at the annual rate of \$111,000 effective February 4, 2014.

RESULT:	ADOPTED [UNANIMOUS]
MOVER:	Gerald Kaminski, Councilmember
SECONDER:	Mary Holtz, Supervisor
AYES:	Holtz, Rogowski, Markel, Kaminski, Wozniak, Benczkowski, Meyers



26. RESOLUTION 2014-101

Assistant Police Chief James J. Speyer, Jr. - Employment Benefits

Sponsored By: Councilmember Kaminski, Supervisor Holtz

BE IT RESOLVED, that Assistant Police Chief James J. Speyer, Jr., receive the stipulated employment benefits outlined in the following sections of the collective bargaining agreement between the Town of Cheektowaga and the Town of Cheektowaga Captains and Lieutenants Association effective February 4, 2014 until modified by the Town Board:

- Section 04.01 Uniform Maintenance Allowance
- Section 06.07 Longevity Pay
- Section 06.08 Redemption of Accumulated Time
- Section 06.09 Education Incentive Pay
- Section 06.11 Off-Duty Authority
- Section 06.12 Jury Duty Pay
- Section 09.01 Holidays
- Section 10.01 Vacations
- Section 10.02 Unused Benefits
- Section 10.03 Vacation Pay Advance
- Section 10.04 Redemption of Time upon Retirement or Separation from Employment
- Section 11.01 Bereavement Leave
- Section 12.01 Personal Leave
- Section 13.01 Sick Leave
- Section 13.05 Work-Related Disability
- Section 13.06 Sick Leave upon Termination
- Section 14.01 Expenses
- Section 15.01 Life Insurance
- Section 15.02 Health Insurance
- Section 15.03 Indemnification
- Section 16.01 Retirement Benefits
- Section 19.02 Tuition

RESULT:	ADOPTED [UNANIMOUS]
MOVER:	Gerald Kaminski, Councilmember
SECONDER:	Mary Holtz, Supervisor
AYES:	Holtz, Rogowski, Markel, Kaminski, Wozniak, Benczkowski, Meyers



27. RESOLUTION 2014-102

Travel Authorization Emergency Services/Natural Disaster Coordinator Earl Loder

Sponsored By: Councilmember Kaminski, Supervisor Holtz

WHEREAS, the New York State Emergency Managers Association Winter Conference is being held February 11 through February 13, 2014 in Syracuse, New York; AND

WHEREAS, Natural Disaster Coordinator Earl Loder has submitted a request for travel authorization along with the proper paperwork in a timely manner; AND

WHEREAS, the total cost to the Town shall not exceed \$387; AND

WHEREAS, these expenses have been budgeted by the Department; NOW, THEREFORE, BE IT

RESOLVED, that Natural Disaster Coordinator Earl Loder be and hereby is authorized to attend the New York State Emergency Managers Association Winter Conference being held February 11 through February 13, 2014 in Syracuse, New York.

RESULT:	ADOPTED [UNANIMOUS]
MOVER:	Gerald Kaminski, Councilmember
SECONDER:	Mary Holtz, Supervisor
AYES:	Holtz, Rogowski, Markel, Kaminski, Wozniak, Benczkowski, Meyers



28. RESOLUTION 2014-103

Travel Authorization Facilities Department/General Crew Chief John Jaroszewski, Jr.

Sponsored By: Councilmember Kaminski, Supervisor Holtz

WHEREAS, the WTC Thirty-Hour Pesticide Certification and Re-Certification (Applicator License/Emerald Ash) is being held February 3 through February 6, 2014 in Tonawanda, New York; AND

WHEREAS, General Crew Chief John Jaroszewski, Jr. has submitted a request for travel authorization along with the proper paperwork in a timely manner; AND

WHEREAS, the total cost to the Town shall not exceed \$460; AND

WHEREAS, these expenses have been budgeted by the Department; NOW, THEREFORE, BE IT

RESOLVED, that General Crew Chief John Jaroszewski, Jr., be and hereby is authorized to attend the WTC Thirty-Hour Pesticide Certification and Re-Certification (Applicator License/Emerald Ash) being held February 3 through February 6, 2014 in Tonawanda, New York.

RESULT:	ADOPTED [UNANIMOUS]
MOVER:	Gerald Kaminski, Councilmember
SECONDER:	Mary Holtz, Supervisor
AYES:	Holtz, Rogowski, Markel, Kaminski, Wozniak, Benczkowski, Meyers



29. RESOLUTION 2014-104

Travel Authorization Justice Court/Town Justice Paul Piotrowski

Sponsored By: Councilmember Kaminski, Supervisor Holtz

WHEREAS, the Association of Towns Conference is being held February 16 through February 17, 2014 in New York City; AND

WHEREAS, Town Justice Paul Piotrowski has submitted a request for travel authorization along with the proper paperwork in a timely manner; AND

WHEREAS, the total cost to the Town shall not exceed \$1,032; AND

WHEREAS, these expenses have been budgeted by the Department; NOW, THEREFORE, BE IT

RESOLVED, that Town Justice Paul Piotrowski be and hereby is authorized to attend the Association of Towns Conference being held February 16 through February 17, 2014 in New York City.

RESULT:	ADOPTED [UNANIMOUS]
MOVER:	Gerald Kaminski, Councilmember
SECONDER:	Mary Holtz, Supervisor
AYES:	Holtz, Rogowski, Markel, Kaminski, Wozniak, Benczkowski, Meyers



30. RESOLUTION 2014-105

Travel Authorization Police Department/Lieutenant Brian Gould

Sponsored By: Councilmember Kaminski, Supervisor Holtz

WHEREAS, the Hazard Assessment and Response Management for CBRNE Incidents (HARM) is being held March 31 through April 5, 2014 in Anniston, Alabama; AND

WHEREAS, Lieutenant Brian Gould has been recommended to attend said conference; AND

WHEREAS, Police Chief David Zack has submitted a request for travel authorization along with the proper paperwork in a timely manner; AND

WHEREAS, the total cost to the Town shall not exceed \$156; AND

WHEREAS, these expenses have been budgeted by the Department; NOW, THEREFORE, BE IT

RESOLVED, that Lieutenant Brian Gould be and hereby is authorized to attend the Hazard Assessment and Response Management for CBRNE Incidents (HARM) being held March 31 through April 5, 2014 in Anniston, Alabama.

RESULT:	ADOPTED [UNANIMOUS]
MOVER:	Gerald Kaminski, Councilmember
SECONDER:	Mary Holtz, Supervisor
AYES:	Holtz, Rogowski, Markel, Kaminski, Wozniak, Benczkowski, Meyers



31. RESOLUTION 2014-106

Travel Authorization Police Department/Lieutenant Brian Coons, Sergeant Lawrence Bauer, Sergeant Jeffrey Schmidt, Police Officer Dennis Kusak

Sponsored By: Councilmember Kaminski, Supervisor Holtz

WHEREAS, the International Law Enforcement Educators and Trainers Association Annual Conference (ILEETA) is being held March 23 through March 29, 2014 in Lombard, Illinois; AND

WHEREAS, Lieutenant Brian Coons, Sergeant Lawrence Bauer, Sergeant Jeffrey Schmidt, and Police Officer Dennis Kusak have been recommended to attend said conference; AND

WHEREAS, Police Chief David Zack has submitted a request for travel authorization along with the proper paperwork in a timely manner; AND

WHEREAS, the total cost to the Town shall not exceed \$5,070; AND

WHEREAS, these expenses have been budgeted by the Department; NOW, THEREFORE, BE IT

RESOLVED, that Lieutenant Brian Coons, Sergeant Lawrence Bauer, Sergeant Jeffrey Schmidt, and Police Officer Dennis Kusak, be and hereby are authorized to attend the International Law Enforcement Educators and Trainers Association Annual Conference (ILEETA) being held March 23 through March 29, 2014 in Lombard, Illinois.

RESULT:	ADOPTED [UNANIMOUS]
MOVER:	Gerald Kaminski, Councilmember
SECONDER:	Mary Holtz, Supervisor
AYES:	Holtz, Rogowski, Markel, Kaminski, Wozniak, Benczkowski, Meyers

V. Communications

A. Departmental Communications

1. **Supervisor's Statement of Funds - November 2013**
2. **Building Permits - January 2014**
3. **Minutes: Cheektowaga Conservation Advisory Council - December 5, 2013**

4. **Minutes: Cheektowaga Traffic Safety Commission - December 13, 2013**
5. **Minutes: Cheektowaga Traffic Safety Commission - December 17, 2013**
6. **Minutes: Town Environmental Advisory Committee - January 8, 2014**
7. **Minutes: Cheektowaga Public Library Board of Trustees - January 15, 2014**

B. General Communications

1. **Summons & Order: Wells Fargo Bank, NA vs. Marie Osika aka Maria T. Osika, Town of Cheektowaga & Etal Premises: 116 Autumn Lea Rd., Depew**
2. **Notice of Claim: Paul & Sharon Crabtree vs. Town of Cheektowaga**
3. **Notice of Claim: EPK Properties, LLC vs. Town of Cheektowaga**
4. **Notice of Claim: Roxanne Morgan vs. Town of Cheektowaga**
5. **Notice of Claim: Brian D. Scotch vs. Town of Cheektowaga**
6. **Notice of Claim: Leanne Wagner vs. Town of Cheektowaga**
7. **Notice of Claim: Mary Watson vs. Town of Cheektowaga**

VI. Comments

A. Supervisor's Comments

A Moment of Silence for Eugene Dudek, husband of Joan E. Dudek, retired Receiver of Taxes.

B. Councilmember's Comments

C. Public Comments

- VII. Motion To:** Enter Into Executive Session

RESULT: **ADOPTED [UNANIMOUS]**
MOVER: Mary Holtz, Supervisor
SECONDER: Timothy J. Meyers, Councilmember
AYES: Holtz, Rogowski, Markel, Kaminski, Wozniak, Benczkowski, Meyers

- VIII. Motion To:** Exit Executive Session at 8:25 PM

RESULT: **ADOPTED [UNANIMOUS]**
MOVER: Charles Markel, Councilmember
SECONDER: James P. Rogowski, Councilmember
AYES: Holtz, Rogowski, Markel, Kaminski, Wozniak, Benczkowski, Meyers

IX. Motion To: Adjourn at 8:26 PM

RESULT: **ADOPTED [UNANIMOUS]**
MOVER: James P. Rogowski, Councilmember
SECONDER: Timothy J. Meyers, Councilmember
AYES: Holtz, Rogowski, Markel, Kaminski, Wozniak, Benczkowski, Meyers

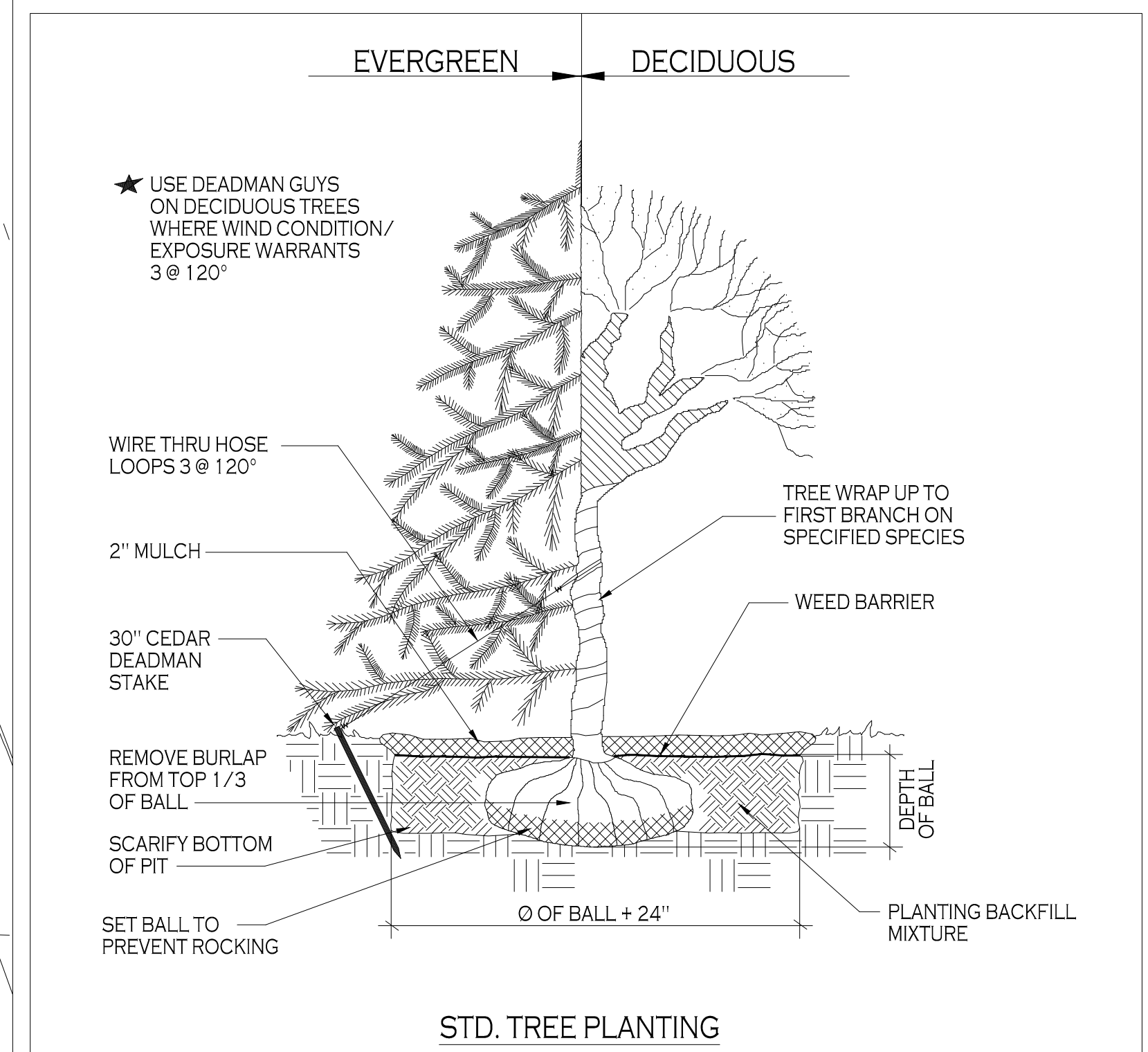
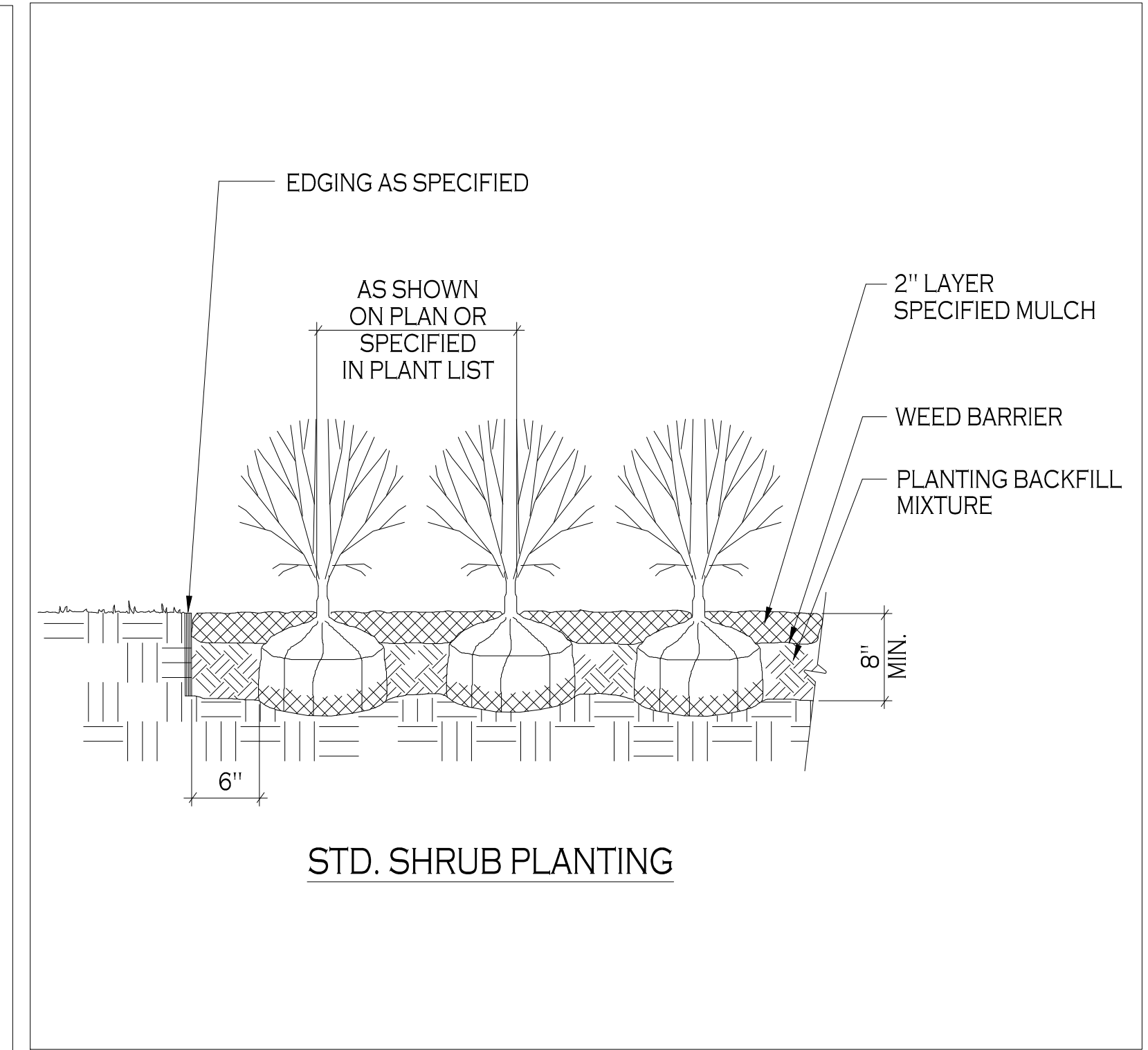
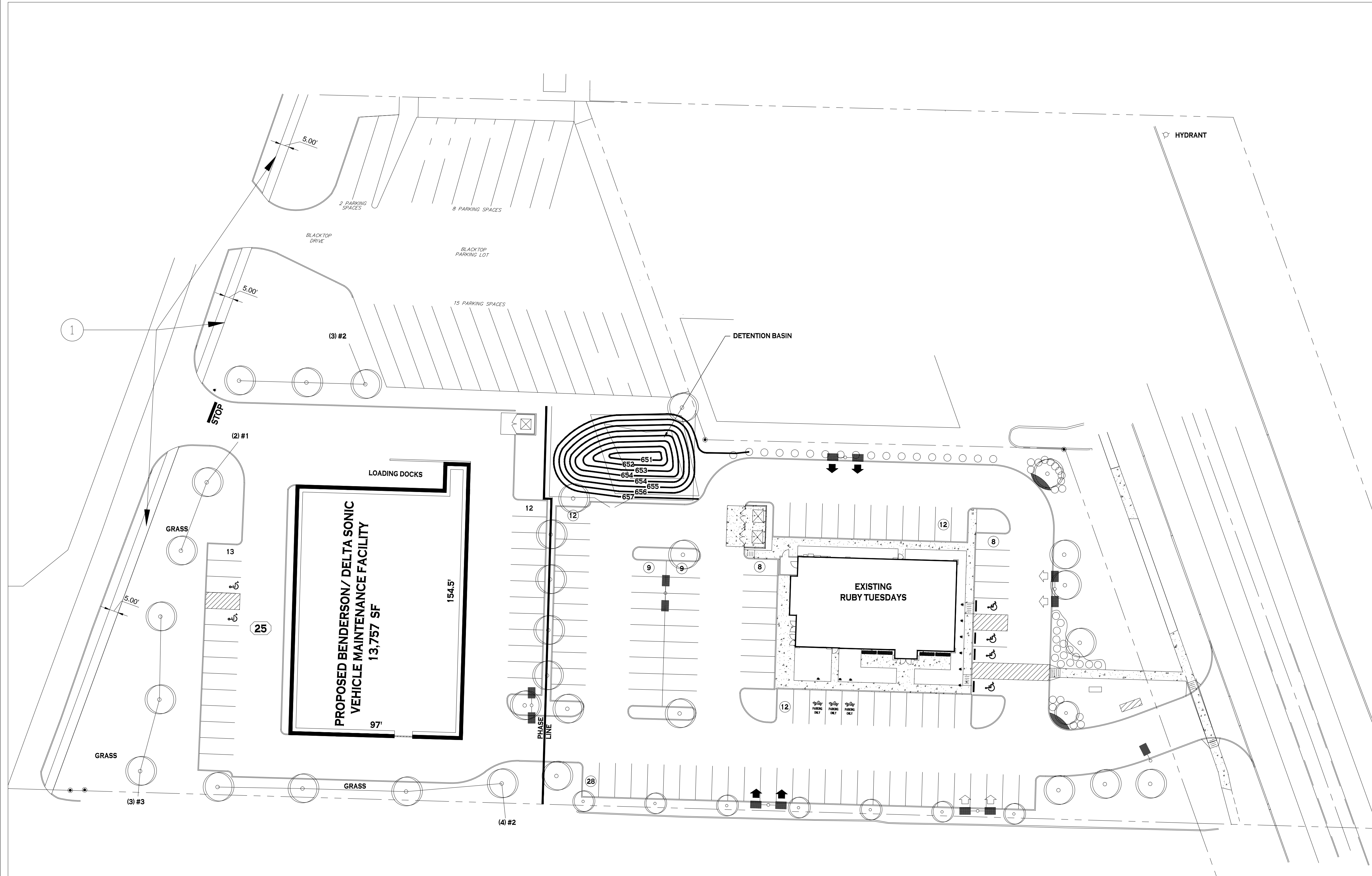

LANDSCAPE PLAN

SCALE 1"=30'

SIDEWALK NOTES:
 1. PROPOSED 5' WIDE SIDEWALK TO BE INSTALLED AT SUCH A TIME AS CONNECTION IS MADE TO UPSTATE MILK PROPERTY BY ALDI'S OR FUTURE OWNER

PLANTING SCHEDULE				
ITEM	BOTANICAL	COMMON	SIZE	QUANTITY
1.	GLEDITSIA TRIACANTHOS INERMIS "SKYCOLE"	SKYLINE HONEYLOCUST	2 1/2" CAL.	4
2.	ACER RUBRUM "RED SUNSET"	RED SUNSET MAPLE	2 1/2" CAL.	7
3.	FRAXIMUS PENN. "SUMMIT"	SUMMIT ASH	2 1/2" CAL.	3

PROPOSED DELTA
 DALE RD.
 CHEEKTOWAGA, NY 14225

2256 PROPOSED DELTA GARAGE 12-24-2013 DECEMBER 24, 2013

1400 W. BOND ST. SUITE 100 CHEEKTOWAGA, NY 14225
 Phone: (716) 858-6300 Fax: (716) 858-1814
 www.benderson.com

LANDSCAPE PLAN

DRAWN BY: DMN CHECKED BY: MAO SCALE: 1:30

Special Information: THIS DRAWING PREPARED FOR TENANT IMPROVEMENTS TO AN EXISTING BUILDING OR BUILDING CONSTRUCTED BY OTHERS IT IS UNDERSTOOD THAT ANY WARRANTY INFORMATION CONCERNING EQUIPMENT INSTALLED MUST BE FORWARDED TO THE OWNER AND THAT AN AND ALL CONTRACTORS SHALL GUARANTEE THEIR WORK FOR A PERIOD OF ONE YEAR FROM THE DATE OWNERS ACCEPTANCE.

NOTICE

UNAUTHORIZED ALTERATIONS OF THIS DOCUMENT ARE IN VIOLATION OF SECTION #7209 OF THE STATE EDUCATION LAW.

SITE LOCATION MAP

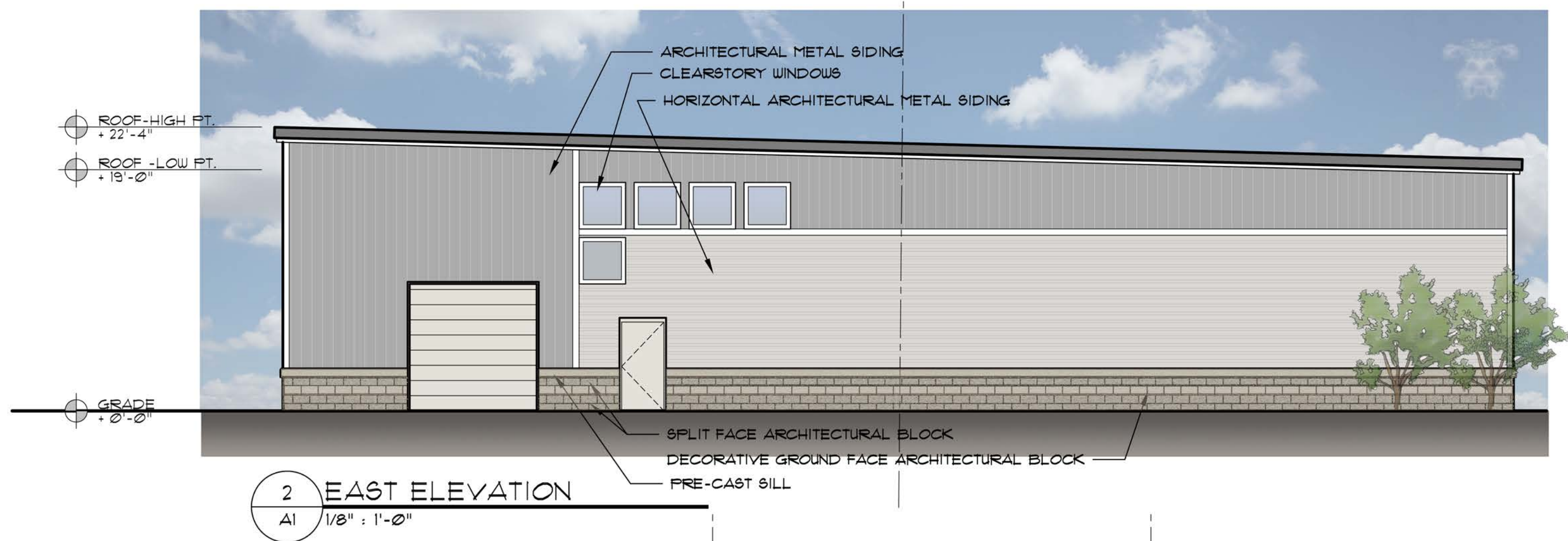
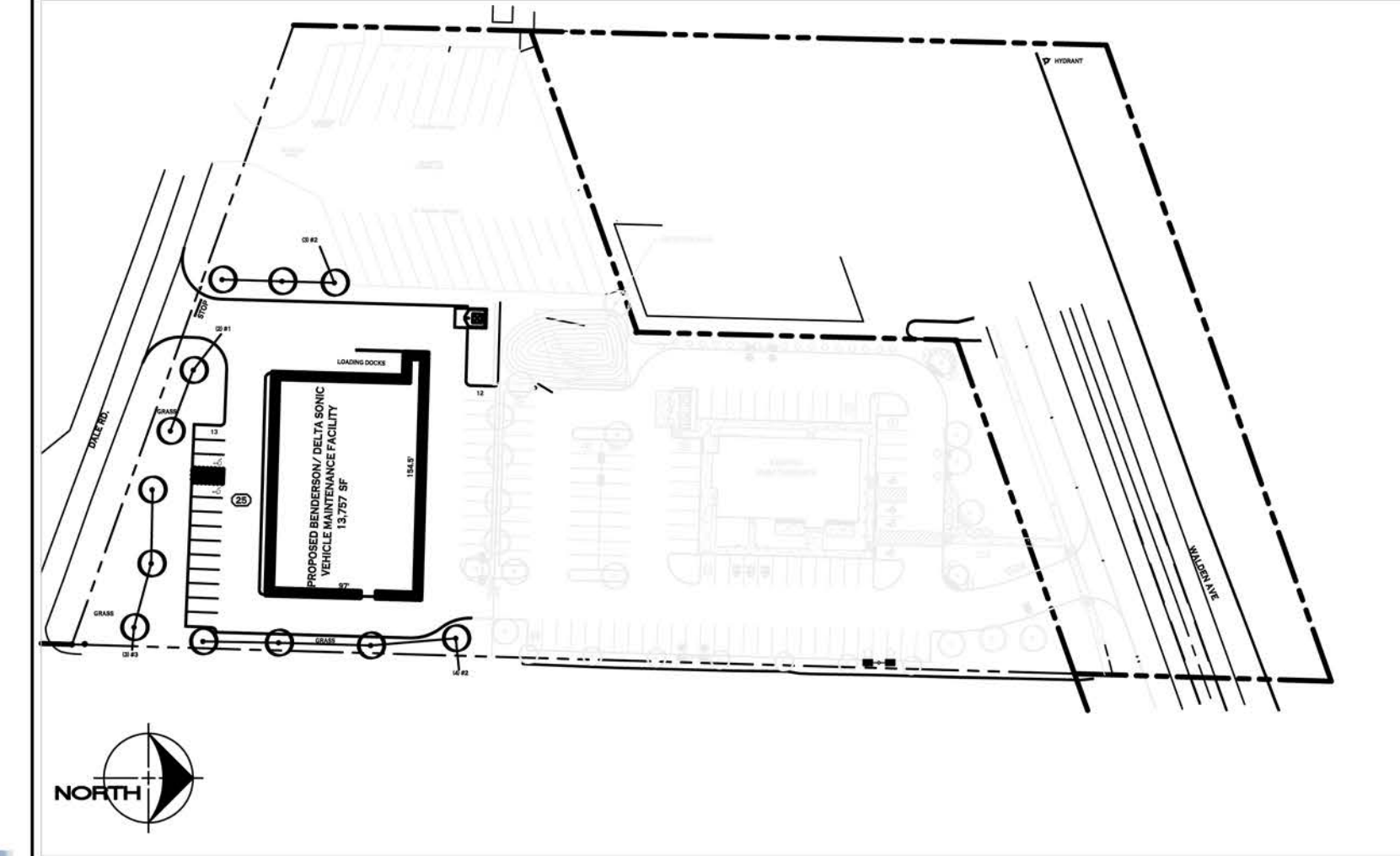

2 EAST ELEVATION
AI 1/8" : 1'-0"

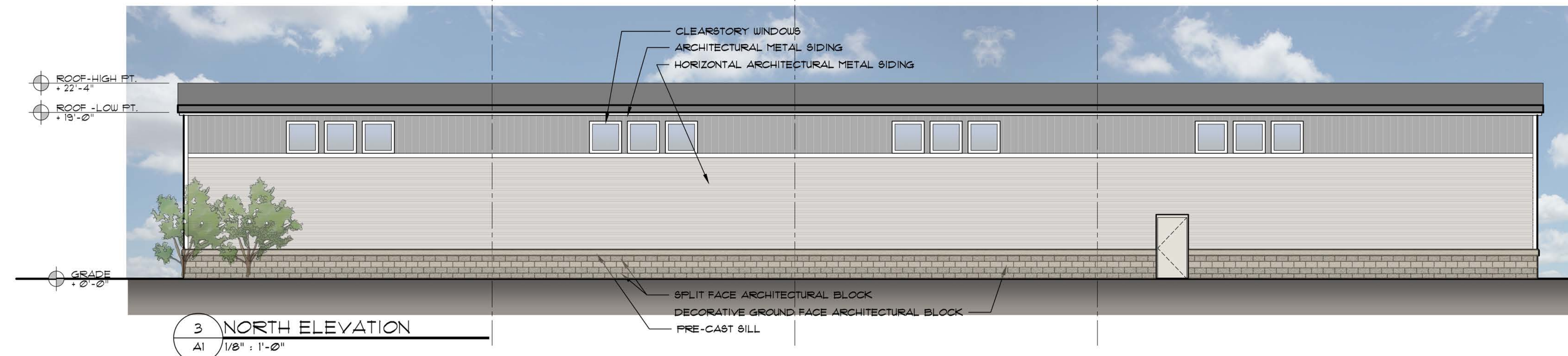

3 NORTH ELEVATION
AI 1/8" : 1'-0"

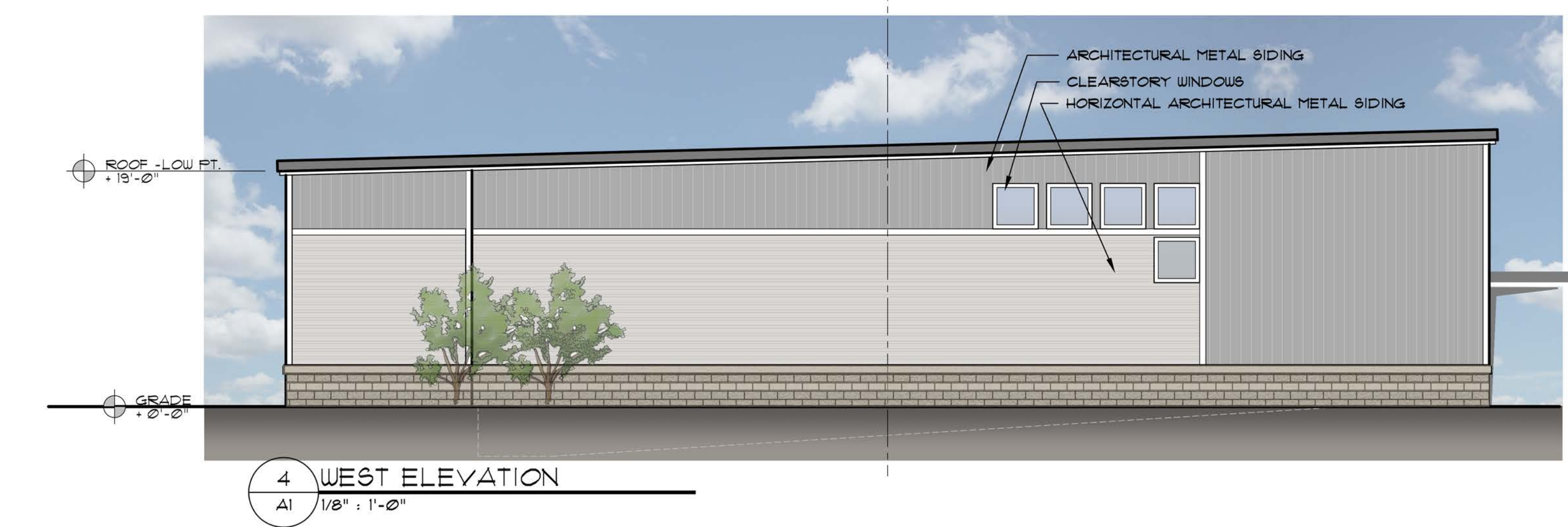

4 WEST ELEVATION
AI 1/8" : 1'-0"

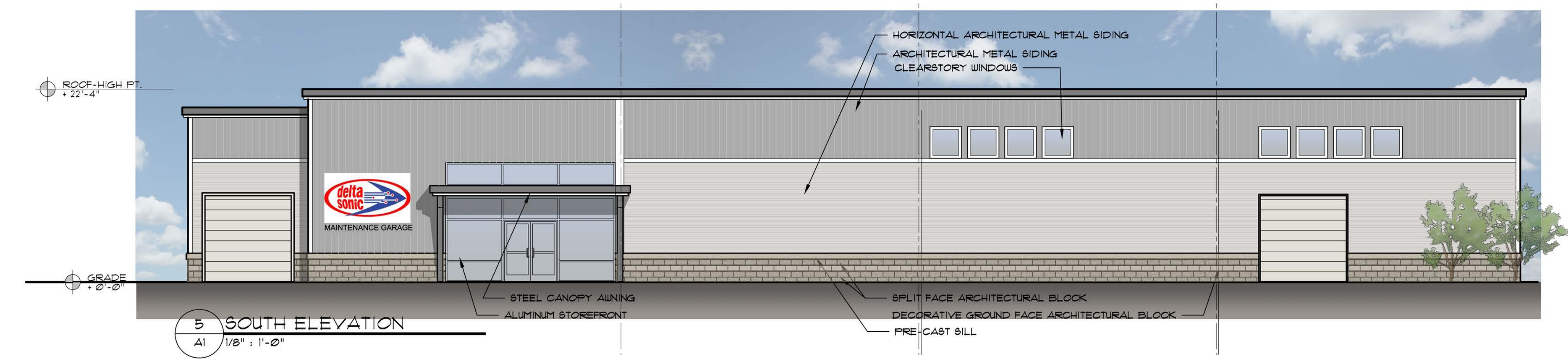

5 SOUTH ELEVATION
AI 1/8" : 1'-0"

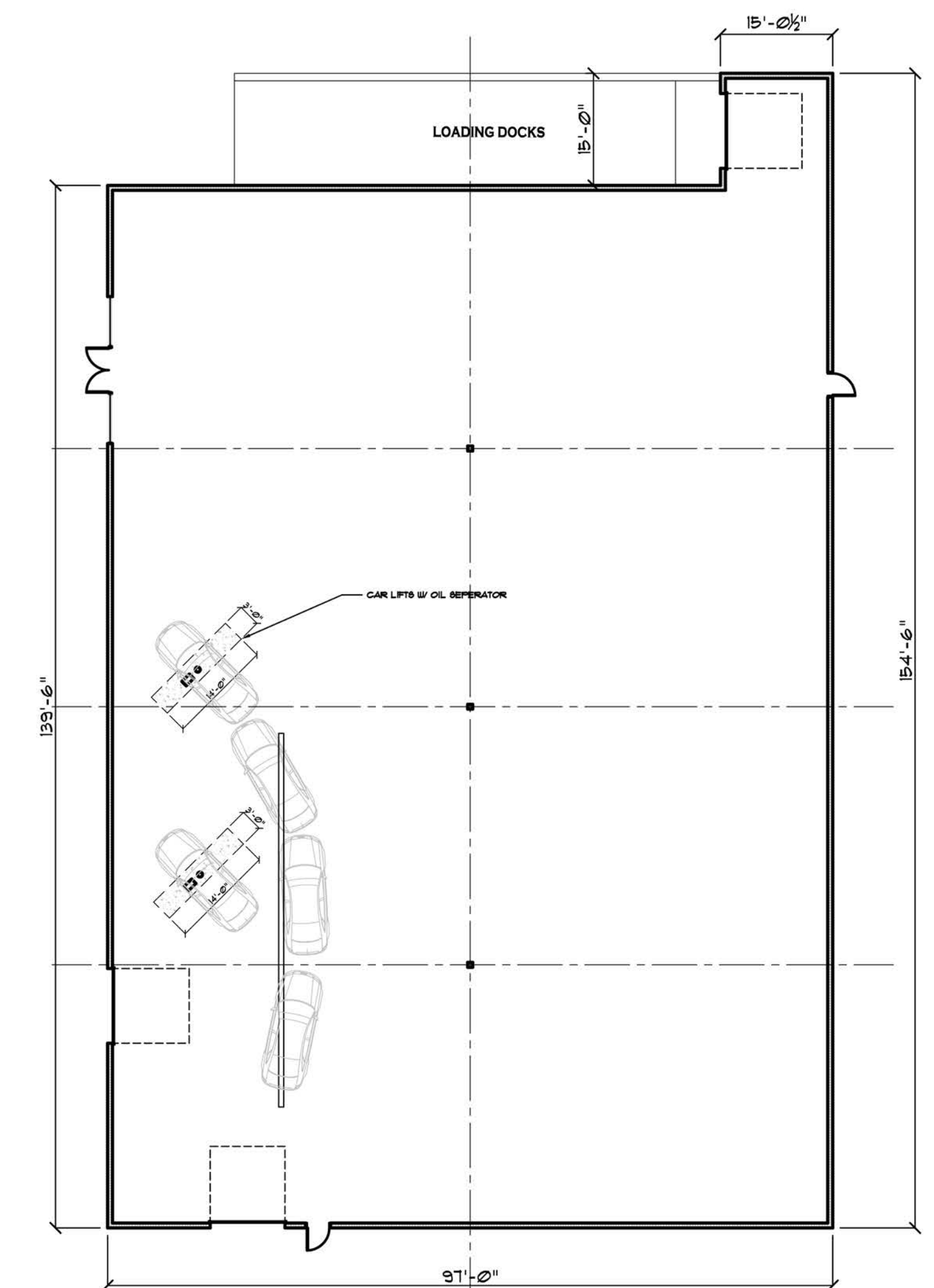

1 FLOOR PLAN
AI 1/16" : 1'-0"

Table with columns: No., DATE, BY, REMARKS

Property No: 2256 Area: 13,757 GSF

PROPOSED GARAGE
WALDEN AVE.
CHEEKTOWAGA, NEW YORK
BENDERSON GARAGE

Title:

James Allen Rumsey
ARCHITECT
BENDERSON
DEVELOPMENT
COMPANY, LLC.
570 Delaware Ave. Buffalo, N.Y. 14202
(716) 865-0211

SEAL

Drawn By: CAR
Checked By:
Date: 12.10.13
Drawing No.
Packet Pg. 44



Town of Cheektowaga

Regular Meeting

~ Minutes ~

3301 Broadway
Cheektowaga, NY 14227
<http://www.town.cheektowaga.ny.us>

Alice Magierski
716-686-3400

Wednesday, February 19, 2014

6:45 PM

Council Chambers

I. Call to Order

6:45 PM Meeting called to order on February 19, 2014 at Council Chambers, 3301 Broadway St, Cheektowaga, NY.

Attendee Name	Organization	Title	Status	Arrived
Mary Holtz	Town of Cheektowaga	Supervisor	Present	
James P. Rogowski	Town of Cheektowaga	Councilmember	Present	
Charles Markel	Town of Cheektowaga	Councilmember	Present	
Gerald Kaminski	Town of Cheektowaga	Councilmember	Present	
Angela M. Wozniak	Town of Cheektowaga	Councilmember	Present	
Diane Benczkowski	Town of Cheektowaga	Councilmember	Present	
Timothy J. Meyers	Town of Cheektowaga	Councilmember	Present	

2. Additional Attendees

Patrick Bowen, Assistant Town Engineer
Ellen Fischer, Executive Director - Youth Board
Carla A. Kosmerl, Director of Community Development
Brian Krause, Director of Finance and Administration

II. Public Comment Period

III. Public Hearings

1. Rezoning - SBL 114.04-5-27.1 - North of 4968 Transit Rd.

COMMENTS - Current Meeting:

This being the time and place advertised for a Public Hearing, the Supervisor directed the Town Clerk to present that such notice has been duly published and posted; upon the order of the Supervisor such proof was duly filed.

The Supervisor announced that the Town Board would hear all persons interested in the subject of the hearing. Comments were heard, after which the Supervisor declared the hearing closed, decision was reserved.

RESULT:	CLOSED [UNANIMOUS]
MOVER:	Charles Markel, Councilmember
SECONDER:	James P. Rogowski, Councilmember
AYES:	Holtz, Rogowski, Markel, Kaminski, Wozniak, Benczkowski, Meyers

2. Demolition of 42 Avery Place

COMMENTS - Current Meeting:

This being the time and place advertised for a Public Hearing, the Supervisor directed the Town Clerk to present that such notice has been duly published and posted; upon the order of the Supervisor such proof was duly filed.

The Supervisor announced that the Town Board would hear all persons interested in the subject of the hearing. Comments were heard, after which the Supervisor declared the hearing closed, decision was reserved.

RESULT: **CLOSED [UNANIMOUS]**
MOVER: Charles Markel, Councilmember
SECONDER: Mary Holtz, Supervisor
AYES: Holtz, Rogowski, Markel, Kaminski, Wozniak, Benczkowski, Meyers

IV. From the Table



1. RESOLUTION 2014-99

Appointment of Planning Board Chairman

Sponsored By: Councilmember Markel, Councilmember Kaminski

WHEREAS, the term of the Chairman of the Planning Board expired as of December 31, 2013, and

WHEREAS, Stanley J. Kaznowski III has expressed an interest in serving as Chairman of the Planning Board, and

WHEREAS, Stanley J. Kaznowski III meets the qualifications for said position and merits appointment, NOW, THEREFORE, BE IT

RESOLVED, that Stanley J. Kaznowski III, of Cheektowaga, New York be and hereby is appointed to the position of Chairman of the Planning Board, effective immediately and terminating on December 31, 2018.

RESULT:	ADOPTED [4 TO 3]
MOVER:	Charles Markel, Councilmember
SECONDER:	Gerald Kaminski, Councilmember
AYES:	Mary Holtz, Charles Markel, Gerald Kaminski, Diane Benczkowski
NAYS:	James P. Rogowski, Angela M. Wozniak, Timothy J. Meyers

V. Resolutions



1. RESOLUTION 2014-107

Transfer of Funds-2013

Sponsored By: Councilmember Kaminski, Supervisor Holtz

BE IT RESOLVED, that the following transfer is hereby approved and made part hereof;

GENERAL

FROM:	100.1010.1901	Regular Payroll	\$1,200.00
	100.1110.1901	Regular Payroll	1,984.00
	100.1110.4082	Business Travel	1,388.00
	100.1220.4088	Travel, Training & Conferences	1,454.00
	100.1910.4711	Contingency	13,787.00
	100.1315.1902	Overtime Payroll	2,063.00
	100.1315.2201	Office Equipment	1,200.00
	100.1315.4011	Printed Forms	2,445.00
	100.1315.4001	Office Supplies	478.00
	100.1315.4088	Travel, Training & Conferences	1,152.00
	100.1355.4323	Assessor Contracted	18,854.00
	100.1355.1971	Part Time Regular	3,300.00
	100.1410.1901	Regular Payroll	1,551.00
	100.1410.1931	Vacation Sellback	1,500.00
	100.1420.1971	PT Regular	811.00
	100.1420.4014	Misc. Filing Fees	25.00
	100.1430.1901	Regular Payroll	1,760.00
	100.1430.4088	Travel, Training & Conferences	1,108.00
	100.1910.4711	Contingency	48,893.00
	100.1440.1901	Regular Payroll	1,573.00
	100.1625.1951	Seasonal Regular	2,325.00
	100.1625.1901	Regular Payroll	16,052.00
	100.1625.1902	Overtime Payroll	4,618.00
	100.1625.1951	Seasonal Regular	14,350.00
	100.1640.1901	Regular Payroll	17,541.00
	100.1640.1902	Overtime Payroll	1,157.00
	100.1640.1914	Shift Differential	2,148.00
	100.1640.4167	Diesel Allocated	128,699.00
	100.1640.4021	Maintenance Supplies	1,882.00
	100.3310.1971	Part Time Regular	12,354.00
	100.3510.1902	Overtime Payroll	3,200.00
	100.3510.1917	Clothing Allowance	88.00
	100.5132.4221	Gas Highway	4,010.00
	100.1220.4001	Office Supplies	2,017.00
	100.1910.4711	Contingency	3,246.00
	100.6510.4301	Room Rental	27.00
	100.7110.1901	Regular Payroll	7,853.00
	100.7140.1914	Shift Differential	1,050.00
	100.7140.1971.1611	Part Time Regular	3,793.00
	100.7140.1971.1614	Part Time Regular	2,458.00
	100.7140.1971.1630	Part Time Regular	2,702.00
	100.7180.1971.1902	Part Time Regular	805.00
	100.7180.1971.1903	Part Time Regular	5,983.00

	100.7310.1902	Overtime Payroll	2,043.00
	100.7310.1971.1803	Part Time Regular	3,158.00
	100.7310.1971.1804	Part Time Regular	3,857.00
	100.7310.1971.1814	Part Time Regular	1,210.00
	100.7310.4693	Dev. Dis.	3,397.00
	100.7550.2039	Polish Festival	17,027.00
	100.7550.2040	Crabapple Festival	5,086.00
	100.1910.4711	Contingency	19,378.00
	100.7620.1931	Vacation Sellback	107.00
	100.1685.1971	Part Time Regular	3,894.00
	100.1685.2000	Equipment	618.00
	100.1320.4145	Professional Services	1,760.00
	100.1910.4082	Gov't Business Travel	2,297.00
	100.1910.4709	Management Studies	5,000.00
	100.1910.4785	Neighborhood Emergency Assistance	13,944.00
	100.3020.1914	Shift Differential	2,367.00
	100.3020.1932	Sick Sellback	1,207.00
	100.3020.4022	Maintenance Contract	15,939.00
	100.3020.4093	Training	2,392.00
	100.3020.4203	Cellular Phones	17,900.00
	100.3020.4431	Equipment Repairs	140.00
	100.3120.1902	Overtime Payroll	56,758.00
	100.3120.1907	Court Time	103,727.00
	100.3120.1908	Training	82,193.00
	100.3120.1911	Longevity	7,300.00
	100.3120.1914	Shift Differential	3,592.00
	100.3120.1917	Clothing Allowance	8,000.00
	100.3120.1931	Vacation Sellback	107,737.00
	100.3120.1971	Part Time Regular	5,835.00
	100.3120.1989	Comp Time Sellback	16,908.00
	100.3120.4007	Emergency Response	347.00
	100.3120.4031	Meals to Prisoners	899.00
	100.9010.8141	Medical Insurance Employee	197,912.00
	100.9010.8143	Retiree Medical Insurance	197,911.00
TO:	100.1010.1990	Other pay	\$1,200.00
	100.1110.1902	Overtime Payroll	784.00
	100.1110.1990	Other Pay	1,200.00
	100.1110.4321	Data Processing Services	1,388.00
	100.1220.1901	Regular Payroll	1,454.00
	100.1220.4008	Disaster Coord. Expense	2,728.00
	100.1220.4957	Grant Development	2,748.00
	100.1315.1901	Regular Payroll	6,103.00
	100.1315.1931	Vacation Sellback	1.00
	100.1315.4431	Maintenance Agreement	1,234.00
	100.1355.1901	Regular Payroll	18,854.00
	100.1355.1990	Other Pay	3,300.00
	100.1410.1902	Overtime Payroll	173.00
	100.1410.2201	Office Equipment	27.00
	100.1410.4055	Ordinance Code	2,067.00
	100.1410.4593	Contracted Steno	784.00
	100.1420.1931	Vacation Sellback	811.00
	100.1420.4013	Law Books	25.00
	100.1420.4501	Contracted Legal	8,311.00

100.1430.1931	Vacation Sellback	1,760.00
100.1430.1932	Sick Sellback	915.00
100.1430.4001	Office Supplies	35.00
100.1430.4011	Printing Contracts	655.00
100.1430.4502	Legal Personnel	20,932.00
100.1440.1931	Vacation Sellback	799.00
100.1440.4325	Copy Machine Supplies	774.00
100.1625.1914	Shift Differential	2,088.00
100.1625.1931	Vacation Sellback	26.00
100.1625.1971	Part Time Regular	211.00
100.1625.4021	Maintenance Supplies	1,433.00
100.1625.4202	Telephone Townwide	5,766.00
100.1625.4205	Telephone System Maintenance	22,190.00
100.1625.4217	Utilities	31,261.00
100.1625.4432	Repairs & Maintenance	1,834.00
100.1640.1931	Vacation Sellback	1,299.00
100.1640.1971	Part Time Regular	247.00
100.1640.2509	Cargo Van	20,850.00
100.1640.4163	Diesel Purchases	128,699.00
100.1640.4449	Senior Citizens Repairs	332.00
100.3310.1902	Overtime Payroll	12,354.00
100.3510.1932	Sick Sellback	996.00
100.3510.1971	Part Time Regular	1,437.00
100.3510.4432	Repairs & Maintenance	855.00
100.5010.1931	Vacation Sellback	4,010.00
100.6410.4194	Media Publicity	2,723.00
100.6410.4195	Events	2,540.00
100.6510.4311	Veterans Affairs Committee	27.00
100.7110.1902	Overtime Payroll	7,707.00
100.7110.2201	Office Equipment	35.00
100.7110.4191	Misc. Expense	111.00
100.7140.1901	Regular Payroll	2,078.00
100.7140.1971.1631	Part Time Regular	362.00
100.7140.4999	Credit Card Expense	329.00
100.7180.1971.1901	Part Time Regular	2,756.00
100.7180.2055	Pool	12,000.00
100.7310.1901	Regular Payroll	12,500.00
100.7310.2501	Other Equipment	296.00
100.7310.4689	Conservation Corp	135.00
100.7550.4374	Polish Festival	33,288.00
100.7550.4375	Crabapple Festival	8,203.00
100.7620.1911	Longevity	100.00
100.7620.1914	Shift Differential	7.00
100.1685.1901	Regular Payroll	1,993.00
100.1685.1902	Overtime Payroll	3,797.00
100.1685.4001	Office Supplies	3.00
100.1685.4051	Records Management	479.00
100.1910.4261	Postage	8,417.00
100.1910.4322	Contracted Services HEAP	10,166.00
100.1910.4706	Real Property Taxes	2,758.00
100.3020.1901	Regular Payroll	89,548.00
100.3020.1902	Overtime Payroll	52,272.00
100.3020.1911	Longevity	4,800.00
100.3020.1931	Vacation Sellback	26.00

	100.3020.2513	Communication Equipment	2,833.00
	100.3120.1901	Regular Payroll	654,384.00
	100.3120.1918	Education	1,500.00
	100.3120.1932	Sick Sellback	11,151.00
	100.3120.1936	Holiday Sellback	3,632.00
	100.3120.2205	Grant Expenditures	5,711.00
	100.3120.2501	Police Other Equipment	247.00
	100.3120.4001	Office Supplies	223.00
	100.3120.4005	Community Service Supplies	9.00
	100.3120.4008	Awards	20.00
	100.3120.4009	Scientific Investigation	444.00
	100.3120.4081	Membership Dues	170.00
	100.3120.4091	Ammunition	1,994.00
HIGHWAY			
FROM:	300.5141.1901	Regular Payroll	\$84,811.00
	300.5150.4177	Receivers Pipe	6,324.00
	300.9010.8141	Medical Insurance Employees	25,284.00
	300.9010.8143	Medical Insurance Retirees	19,006.00
TO:	300.5130.4087	Conferences & Seminars	\$320.00
	300.5140.4291	Shade Trees	19,150.00
	300.5141.1902	Overtime Payroll	78,448.00
	300.5141.1932	Sick Sellback	1,733.00
	300.5141.1951	Seasonal Regular	13,328.00
	300.5141.1971	Part Time Regular	251.00
	300.5142.4029	Salt	22,195.00
PART-TOWN			
FROM:	800.3620.1901	Regular Payroll	\$14,636.00
	800.3620.4191	Misc. Expense	6,258.00
	800.3620.1971	Part Time Regular	1,717.00
	800.3620.4514	Acquisition of Properties	3,000.00
	800.3620.4561	Contracted Services	3,620.00
	800.9010.8141	Medical Insurance Employees	9,865.00
	800.9010.8143	Medical Insurance Retirees	9,865.00
TO:	800.3620.1902	Overtime Payroll	\$15,122.00
	800.3620.1990	Other Pay	1,200.00
	800.3620.2201	Office Equipment	1,280.00
	800.3620.4321	Computer Expense	24,637.00
	800.3620.4411	Refunds of Permits	6,472.00
	800.3620.4581	Consulting Fees	250.00

SPECIAL DISTRICTS

FROM:	150.8160.1901	Regular Payroll	\$70,624.00
	150.8160.1911	Longevity	3,250.00
	150.8160.1931	Vacation Sellback	1,266.00
	150.8160.1971	Part Time Regular	5,832.00
	150.8160.8141	Medical Insurance Employee	126,505.00
	150.8160.8143	Medical Insurance Retiree	126,505.00
	150.8160.8151	Group Insurance	277.00
	255.8125.1901	Regular Payroll	11,983.00
	255.8135.1901	Regular Payroll	3,714.00
TO:	150.8160.1902	Overtime Payroll	\$9,890.00
	150.8160.1932	Sick Sellback	56.00
	150.8160.1951	Seasonal Regular	37,323.00
	150.8160.2501	Misc. Equipment	194,810.00
	150.8160.4160	Diesel	91,613.00
	150.8160.4186	Tolls	290.00
	150.8160.8121	Social Security	277.00
	255.8125.1902	Overtime Payroll	4,575.00
	255.8125.1931	Vacation Sellback	80.00
	255.8125.4163	Gas, Oil & Grease	7,328.00
	255.8135.1931	Vacation Sellback	54.00
	255.8135.1932	Sick Sellback	3,040.00
	255.8135.4164	Gas, Oil & Grease	373.00
	255.8135.8121	Social Security	247.00

RESULT:	ADOPTED [UNANIMOUS]
MOVER:	Gerald Kaminski, Councilmember
SECONDER:	Mary Holtz, Supervisor
AYES:	Holtz, Rogowski, Markel, Kaminski, Wozniak, Benczkowski, Meyers



2. RESOLUTION 2014-108

Transfer of Funds-2014

Sponsored By: Councilmember Kaminski, Supervisor Holtz

BE IT RESOLVED, that the following transfer is hereby approved and made part hereof;

CDBG

FROM:	700.1013.0600	Housing Rehab.- Single Family	\$20,264.19
	700.1012.0680	Dom. Violence Investigation Program	4,625.66
	700.1013.0680	Dom. Violence Investigation Program	9,000.00
TO:	700.1013.0752	Rehab Activity Delivery Costs	\$20,264.19
	700.1013.0600	Housing Rehab.- Single Family	13,625.66

RESULT:	ADOPTED [UNANIMOUS]
MOVER:	Gerald Kaminski, Councilmember
SECONDER:	Mary Holtz, Supervisor
AYES:	Holtz, Rogowski, Markel, Kaminski, Wozniak, Benczkowski, Meyers



3. RESOLUTION 2014-109

Warrant

Sponsored By: Councilmember Kaminski, Supervisor Holtz

BE IT RESOLVED, that the following Vouchers & Warrants submitted to the Town of Cheektowaga prior to February 19, 2014 are hereby approved and made part hereof;

GENERAL FUND	\$3,173,382.96
RISK RETENTION FUND	1,099,254.09
NYS HOME PROGRAM	
DEBT	756,968.50
HUD HOUSING REHABILITATION FUND	
SPECIAL DISTRICTS FUND	3,055,474.26
HIGHWAY FUND	838,131.25
CAPITAL FUND	7,101.83
TRUST & AGENCY FUND	2,939.00
HUD CDBG FUND	399.00
PART TOWN FUND	163,729.60
NYS AFFORDABLE HOUSING	
	\$9,097,380.49

RESULT:	ADOPTED [UNANIMOUS]
MOVER:	Gerald Kaminski, Councilmember
SECONDER:	Mary Holtz, Supervisor
AYES:	Holtz, Rogowski, Markel, Kaminski, Wozniak, Benczkowski, Meyers



4. RESOLUTION 2014-110

Adopt Local Law No. 1 of 2014 - A Local Law to Amend the Zoning Law

Sponsored By: Councilmember Markel, Councilmember Rogowski

WHEREAS, by resolution dated January 21, 1992, Local Law No. 1 of the Year 1992 of the Town of Cheektowaga, entitled "A Local Law Relating to Zoning" was adopted, and

WHEREAS, the Petitions Committee has recommended that the Zoning Law be amended:

- 1. to amend Section 260-23.A.(d) to eliminate the Town Zoning Law requirement for fencing around a yard where a pool exists;
2. to amend Section 260-37.(1)(i) to allow by means of special permits in the M2-General Manufacturing District:
a. Compressed Natural Gas filling stations;
b. Biomass Energy Conversion Facilities;
3. to amend Section 260-37.A.(2) to permit concrete crushing operations as an accessory use in a M2-General Manufacturing District;
4. to amend Section 260-44.B. and to enact a new section, Section 260-48, to regulate site lighting for non-residential and multifamily projects;
5. to add a new section, Section 260-454.B. to permit the temporary use of an automobile use area which is accessory to a permitted non-residential use, for the storage of deicing salts between November 1st and April 1st.
6. to amend Section 260-64 in relation to the restoration of damaged structures require commercial business signs to be removed within 30 days after a business leaves the premises.

, and

WHEREAS, a draft of such amendments has been prepared by the Town Building Inspections Department, and

WHEREAS, a public hearing was held on the 3rd day of February, 2014 at 6:45 P.M. at the Town Hall, 3301 Broadway, Cheektowaga, New York to consider the advisability of adopting "A Local Law to Amend the Zoning Law", and

WHEREAS, it is in the public interest to adopt said local law, NOW, THEREFORE, BE IT

RESOLVED, that Local Law No. 1 of the Year 2014, entitled "A Local Law to Amend the Zoning Law", which is attached hereto and made a part hereof, be and the same is hereby enacted, and BE IT FURTHER

RESOLVED, that Local Law No. 1 of the Year 2014 shall be effective upon filing with the Secretary of State, and BE IT FURTHER

RESOLVED, that the Town Clerk shall file one (1) certified copy of this local law in her office and one (1) certified copy with the Secretary of State.

**LOCAL LAW INTRO NO. 2014-1
A LOCAL LAW TO AMEND THE ZONING LAW**

1. Section 260- 23.A.(2)(d) of the Town Code (Zoning Law), which relates to permitted accessory uses in the R-Residence District, shall be amended to read as follows:

(d) Private swimming pool or pool deck, provided that it is located in the rear of the front setback line, is a minimum of five feet from the rear lot line and side lot line and does not occupy any part of a required exterior side yard.

2. Section 260-37.A.(1)(i) of the Town Code (Zoning Law) shall be amended to add a new subsection [5] to permit compressed natural gas filling station, by special permit, in the M2-General Manufacturing District. Said subsection [5] shall read as follows:

[5] Compressed Natural Gas (CNG) filling station as a principal use or, as accessory to a permitted use in the M2- General Manufacturing District, subject to the following limitations:

- (a) All installations shall be consistent with the latest National Fire Protection Association (NFPA) standards for compressed natural gas facilities.
- (b) Storage vessels may be above ground. The limits of section 260-52G of this chapter do not apply to compressed natural gas. The other provisions of section 260-52 shall still apply to a CNG filling station.
- (c) Storage vessels may not exceed a cumulative volume of 70,000 scfm for an initial installation. Additional volume may be considered by the Town Board upon the filing of a second special permit application for a facility expansion if the applicant can show that demand warrants additional volume and that fire safety considerations will not be compromised.
- (d) Appurtenances that support a CNG filling station, including but not limited to the compressor, dryer and storage vessels must be a minimum of (50) fifty feet from the fueling island and shall not be permitted in any required yard.
- (e) The compressor, dryer and storage vessels must be constructed in a permanent fashion and placed on a concrete pad. Mobile installations shall not be permitted.
- (f) The compressor, dryer and storage vessel area shall be screened from public view, and shall include at minimum the following design components:
 - 1. A black chain link fence with black p.v.c. slatting. The fence shall be of sufficient height to provide a security

barrier and hide the ancillary equipment. All components of the fence shall be black in color or have a black vinyl coating. Such fencing may also contain a security topping. The limitations on security topping

2. Vehicle impact protection shall be required around the perimeter of the compressor/dryer, storage vessel area, utilizing vehicle impact bollards. The use of precast jersey barriers shall not be permitted. Poured in place concrete barriers/ extended barrier curbing may be utilized if part of an integral design for the ancillary storage area.
3. In lieu of a fence screen, a non-combustible building meeting the minimum requirements of N.F.P.A may be constructed to screen the ancillary equipment/storage vessel area.

3. Section 260-37.A.(1)(i) of the Town Code (Zoning Law) shall be amended to add a new subsection [6] to permit a biomass energy conversion station, by special permit, in the M2-General Manufacturing District. Said subsection (i) shall read as follows:

[6] Biomass Energy Conversion Facility.

A facility which processes food waste and /or plant material into renewable energy.

4. Section 260-37.A.(2) of the Town Code (Zoning Law) shall be amended to add a new subsection, (e) to allow, as an accessory use in the M2-General Manufacturing District, a concrete crushing operation. Said subsection (e) shall read as follows:

- (e) Crushing concrete as an accessory use to a contractors storage yard for equipment and materials, providing the following conditions are met:
1. The height of the piles of material will not exceed (25) feet off of existing grade.
 2. The crushing operations will be done only during the period of October 1 through March 31.
 3. The crushing unit and operation will meet all requirements of NYS Department of Environmental Conservation and E.P.A.
 4. The crushing unit will be located at least 50 feet from any property line.
 5. Concrete, crushed and uncrushed shall be at least twenty-five (25) feet from any property line.
 6. Hours of operation will be normal business hours of 8:30 AM to 5:00PM, Monday through Friday only.

5. Section 260-44 of the Town Code (Zoning Law), entitled "Limitations on automotive use areas", shall be amended to delete subsection B, which relates to lighting.

6. **Section 260-44.C. of the Town Code (Zoning Law) shall be re-numbered Section 260-44.B .**
7. **Section 260-44.D. of the Town Code (Zoning Law) shall be re-numbered Section 260-44.C.**
8. **Section 260-45 of the Town Code (Zoning Law), entitled “Restriction on use for all existing and new automotive use areas”, shall be amended to add a new subsection B, to read as follows:**
 - A. The temporary use of an automotive use area which is accessory to a permitted non residential use, for the storage of deicing salts used in the maintenance of the accessory automotive use area is permitted between the consecutive months of November 1st through April 1st, providing the following conditions are met:
 1. The salt storage area is not within a required yard,
 2. The area is limited to a maximum volume of 40 cubic yards
 3. Any retaining walls shall be temporary in nature and not exceed 5 feet in height
 4. The storage area shall be disassembled by April 1st and the area shall be broom clean.
 5. All storage areas shall be provided with tarpaulin covers secured tightly and completely covering the salt storage area.

9. **A new section, 260-48 of the Town Code (Zoning Law), entitled “Site Lighting”, shall be added, to read as follows:**

§260-48 Site Lighting

A. Legislative intent/Purpose:

Nonresidential and multifamily buildings and projects shall be designed to provide safe, convenient, and efficient lighting for pedestrians and vehicles. Lighting shall be designed in a consistent and coordinated manner for the entire site and done in such a manner to minimize light pollution. The lighting and lighting fixtures shall be integrated and designed so as to enhance the visual impact of the project on the community and/or should be designed to blend into the surrounding landscape. Lighting fixtures shall be designed, sized and located so as not to cast direct rays of light upon adjoining premises or cause glare hazardous to pedestrians or persons using adjacent public streets. Illumination shall not be used for the purpose of advertising or attracting attention to the principal use, except as permitted by Section 260-50 of the Sign Regulations.

B. Applicability

A site lighting plan shall be required during review of any nonresidential or multifamily development plan submittal pursuant to section 260-29, {Site Plan Approval} of this chapter. The contents of the site lighting plan shall be established during the site plan submission. Site lighting plans shall also be required for the establishment of new exterior lighting on existing facilities which do not require site plan approval. Such plans shall be reviewed by the Office of Building Inspections for consistency with the provisions of this section.

C. Site Lighting Design Requirements

Lighting shall be used to provide safety while accenting key architectural elements and to emphasize landscape features. Light fixtures shall be designed as an integral design element that complements the design of the project. This can be accomplished through style, material or color. All lighting fixtures designed or placed so as to illuminate any portion of a site shall meet the following requirements:

1. Fixture (Luminaire)

The light source shall be concealed and shall not be visible from any street right-of-way or adjacent properties. In order to direct light downward and minimize the amount of light spillage into the night sky and onto adjacent properties, all lighting fixtures shall be cutoff fixtures (dark sky compliant). Only architectural lighting may be directed upward provided that all other provisions of this Section are met.

2. Fixture Height

Lighting fixtures shall be a maximum of 25 feet in height within parking lots and shall be a maximum of 15 feet in height within non-vehicular pedestrian areas.

3. Limit Lighting to Periods of Activity

The use of sensor technologies, timers or other means to activate lighting during times when it will be needed may be required by the Town of Cheektowaga to promote compatibility between different land uses, and mitigate for any potential light nuisances.

4. Illumination Level. Illumination levels shall be measured in footcandles.

5. All site lighting shall be designed so that the level of illumination, as measured in footcandles at any one point, meets the standards in the table below.

6. Minimum and maximum levels are measured on the pavement within the lighted area. Average level is the overall, generalized ambient light level, and is measured as a not-to-exceed value. The average level shall be calculated using only the area of the site intended to receive illumination.

Lighting Type	Lighting Level (footcandles)		
	Minimum	Average	Maximum
Architectural	0.0	1.0	5.0
Canopy Area	2.0	10.0	15.0
Multifamily Parking Lots	0.20	1.0	8.0
Nonresidential and Multifamily Entrances and Exits	1.0	5.0	15.0
Nonresidential Parking Lots	0.2	1.5	10.0
Security	0.2	1.0	10.0
Vehicle Sales, Rental and Leasing	0.2	3.0	15.0
Walkways, Landscape or Decorative	0.2	0.8	5.0

7. All outdoor lighting shall be designed and located such that the maximum illumination measured in footcandles at the property line does not exceed 0.2 on

adjacent residential use, and 0.5 on adjacent commercial sites and public rights-of-way.

8. Lighting shall not be oriented so as to direct glare or excessive illumination onto streets in a manner that may distract or interfere with the vision of drivers on such streets.

D. Lighting Required for Specific Uses

1. Sites Adjacent to Residential Uses

All lights shall be shielded so as to deflect light away from any residential use.

Illumination at the public right-of-way line when a nonresidential use is across the public right-of-way from a residential use shall not exceed one footcandle.

All light fixtures located within 50 feet of any residential use shall not exceed 15 feet in height.

Unless properly shielded, security lighting fixtures such as wall packs shall not face a residential use.

2. Canopy Area Lighting

All development that incorporates a canopy area over fuel sales, automated bank machines, or similar installations shall use a recessed lens cover flush with the bottom surface of the canopy that provides a cutoff or shielded light distribution. Areas under a vehicular canopy shall have an average of 10 foot candles as measured at ground level at the inside of the outside edge of the canopy.

3. Automated Teller Machines

An automated teller machine (ATM) shall be illuminated in accordance with the ATM Safety Act (NYS Banking Law, Article II-AA).

E. Prohibited Light Sources

Except as otherwise provided in this Section, the following light sources, light fixtures and /or lighting methods shall not be used for exterior lighting.

1. Wooden utility poles, with or without overhead electric.
2. Cobra-head-type fixtures or fixtures with a convex lens.
3. Searchlights and other high-intensity narrow-beam fixtures.
4. Lighting fixtures that have flashing, rotating, moving, pulsing or alternating colored sources, except between Thanksgiving Day and January 15th.

10. Section 260-64 of the Town Code (Zoning Law), entitled "Restoration of damaged structures", shall be amended, to add the following language at the end of said section:

This provision shall not affect the restoration of lawful nonconforming multifamily dwellings originally constructed on land parcels of 1.0 acre or greater in land area. Prior to such restoration, the provisions of section 260-47.1 (site plan approval) shall be required when 75% or more of the buildings within a multifamily development are destroyed.

RESULT:	ADOPTED [UNANIMOUS]
MOVER:	Charles Markel, Councilmember
SECONDER:	James P. Rogowski, Councilmember
AYES:	Holtz, Rogowski, Markel, Kaminski, Wozniak, Benczkowski, Meyers



5. RESOLUTION 2014-111

Award of Bid (#2014-1) - Youth & Recreation Clothing

Sponsored By: Councilmember Wozniak, Councilmember Rogowski

WHEREAS, sealed bids were duly received by the Town Board at a bid opening on January 22, 2014 for the furnishing of clothing as a result of advertising thereof, and such bids were referred to the Department of Youth and Recreational Services for analysis, tabulation and report, and

WHEREAS, such analysis, tabulation and report have been complete, BE IT

RESOLVED that bids be awarded to the lowest responsible bidder meeting specifications, and to be in the best interest of the Town of Cheektowaga for the 2014, 2015, 2016 calendar years:

Laux Sporting Goods Inc
25 Pineview Drive
Amherst, NY 14228

Jim Ludtka Sporting Goods
3950 Broadway
Depew, NY 14043

Great Idea Promotions
10057 Greiner Road Suite 7
Clarence, NY 14031

ADPRO Sports
55 Amherst Vila Road
Buffalo, NY 14225

C* Shore Design
37 South Shore Drive
Alden, NY 14004

BE IT FURTHER RESOLVED that the costs resulting from the awarding of this bid are funded through 7140, 7180 and 7310 accounts for cost centering purposes.

RESULT:	ADOPTED [UNANIMOUS]
MOVER:	Angela M. Wozniak, Councilmember
SECONDER:	James P. Rogowski, Councilmember
AYES:	Holtz, Rogowski, Markel, Kaminski, Wozniak, Benczkowski, Meyers



6. RESOLUTION 2014-112

Award of Bid for Demolition and Asbestos Abatement of 137 David Avenue (BID 2014-06 LAW)

Sponsored By: Councilmember Markel, Supervisor Holtz

WHEREAS, a Notice to Bidders was advertised for the Demolition and Asbestos Abatement of structures at 137 David Avenue (BID 2014-06 LAW); and

WHEREAS, bid proposals were received and opened on February 5, 2014 for said demolition and asbestos abatement; and

WHEREAS, the proposals were reviewed by the Town Attorney and, based on proposals submitted, the Town Attorney has recommended that this Town Board award the bid for the demolition and asbestos abatement of the structures at 137 David Avenue to Regional Environmental Demolition, Inc.; NOW, THEREFORE, BE IT

RESOLVED, that this Town Board hereby awards the bid for the demolition and asbestos abatement of structures located at 137 David Avenue to:

Regional Environmental Demolition, Inc.
3695 Pine Avenue
Niagara Falls, New York

for the bid price of \$23,800.00, being the lowest responsible bid meeting specifications; and BE IT FURTHER

RESOLVED, that the Supervisor be and hereby is directed to execute an agreement with Regional Environmental Demolition, Inc., for the aforesaid services, and BE IT FURTHER

RESOLVED, that moneys for said services shall be appropriated from budget line item number 0800-800-0440.

RESULT:	ADOPTED [UNANIMOUS]
MOVER:	Charles Markel, Councilmember
SECONDER:	Mary Holtz, Supervisor
AYES:	Holtz, Rogowski, Markel, Kaminski, Wozniak, Benczkowski, Meyers



7. RESOLUTION 2014-113

Notice to Bidders for Demolition with Asbestos Abatement of 19 Euclid Avenue (BID 2014-10 LAW)

Sponsored By: Councilmember Markel, Supervisor Holtz

WHEREAS, it is in order that bids be advertised for the demolition and asbestos abatement of structures located at 19 Euclid Avenue, Cheektowaga, New York; and

WHEREAS, specifications for same have been prepared by Nussbaumer & Clarke, Inc.;
NOW, THEREFORE, BE IT

RESOLVED, that the Town Clerk be and hereby is directed to publish a Notice to Bidders (BID 2014-10 LAW) for the demolition and asbestos abatement of structures located at 19 Euclid Avenue, said notice to be published in the CHEEKTOWAGA BEE, and BE IT FURTHER

RESOLVED, that sealed bids will be received and opened by the Town Clerk at a public bid opening to be held in the Council Chambers at the Cheektowaga Town Hall on Wednesday, March 5, 2014 at 11:00 A.M.



NOTICE TO BIDDERS

Sealed proposals will be received by the Town Clerk of the Town of Cheektowaga on Wednesday, March 5, 2014 at 11:00 A.M. at the Cheektowaga Town Hall, 3301 Broadway, Cheektowaga, New York, for the demolition and asbestos abatement of structures located at 19 Euclid Avenue (BID 2014-10 LAW), situate in the Town of Cheektowaga, New York.

Information for bidders and specifications may be obtained from the Town Clerk at her office in said Town.

The Town Board reserves the right to consider informal any bid not prepared and submitted in accordance with the provisions of the specification and contract documents, and may waive any informalities, make an award to other than the low bidder, or reject any or all bids should it be in the best interest of the Town.

BY ORDER OF THE TOWN BOARD OF THE TOWN OF CHEEKTOWAGA, ERIE COUNTY, NEW YORK.

Alice Magierski, Town Clerk

Dated: 19 February 2014

RESULT: **ADOPTED [UNANIMOUS]**
MOVER: Charles Markel, Councilmember
SECONDER: Mary Holtz, Supervisor
AYES: Holtz, Rogowski, Markel, Kaminski, Wozniak, Benczkowski, Meyers



8. RESOLUTION 2014-114

Notice to Bidders - Sewer Maintenance Building Addition & Renovations (Bid #2014-11)

Sponsored By: Councilmember Meyers, Supervisor Holtz

WHEREAS, the architectural firm of Aurora Architectural Design, PC, has completed Construction Documents (Plans & Specifications) for the Town of Cheektowaga Sewer Maintenance Building Addition and Renovations Project (Bid 2014-11) located at 200 Southern Parkway, AND

WHEREAS, the completion of said Construction Documents enables the solicitation of competitive bids in the field of General Construction (to include Electrical, HVAC and Plumbing Work) NOW, THEREFORE, BE IT

RESOLVED, that the Town Clerk be directed to publish a Notice to Bidders for the Cheektowaga Sewer Maintenance Building Addition and Renovations Project located at 200 Southern Parkway, Cheektowaga, New York 14225, said notice to be published in the CHEEKTOWAGA BEE, AND BE IT FURTHER

RESOLVED, that sealed bids will be received on the 19th day of March, 2014 at 11:00 am at a public bid opening to be held in the Council Chambers in the Cheektowaga Town Hall, 3301 Broadway, Cheektowaga, New York 14227.



NOTICE TO BIDDERS

Notice is hereby given that sealed proposals will be received and considered by the Town Board of the Town of Cheektowaga, County of Erie, State of New York, on the 19th day of March, 2014 at 11:00 am in the Town Hall Council Chambers, 3301 Broadway, Cheektowaga, New York for furnishing all labor, materials, tools, equipment and incidentals required for General Construction Work including Electrical Work, HVAC Work and Plumbing Work for the Addition and Renovations Project for the Sewer Maintenance Building (Bid 2014-11) located at 200 Southern Parkway, Cheektowaga, New York 14225, complete in place and ready for use in accordance with the Contract Documents, therefore, including Plans, Specifications, Instructions to Bidders, etc. prepared by Aurora Architectural Design PC, Consulting Architect.

All proposals shall be submitted on the forms furnished herein and the entire volume, including any addenda, shall be submitted in a sealed envelope and addressed to the Town Board of the Town of Cheektowaga, 3301 Broadway, Cheektowaga, New York 14227 to the attention of Alice Magierski, Town Clerk.

Copies of the Contract Documents (Plans, Specifications and Instructions to Bidders) may be examined at the Office of the Town Clerk, Town Hall, 3301 Broadway, Cheektowaga, New York 14227; copies may be purchased from the Town Clerk's Office and can be obtained upon payment of \$50.00 in the form of one (1) check made payable to the Town of Cheektowaga for each copy requested. Neither the Owner nor the Engineer will be responsible

for full or partial sets of Contract Documents, including any addenda obtained from any other source.

Any bidder returning Plans and Specifications in good condition within ten (10) days following the award of the contract or the rejection of the bids will be refunded the full amount of the deposit. Deposits will not be refunded for non-bidders. Material suppliers and anyone returning the Plans and Specifications before the bid opening will also be classed as non-bidders. Any bidders requesting more than one (1) set of Plans and Specifications may purchase the excess, but it is understood that they are non-refundable.

The work shall be completed within 210 consecutive calendar days; to begin five (5) days after the "Order to Commence Work" has been issued.

A pre-bid inspection for the project will be held at the site at 10:00 am, Wednesday, March 5, 2014.

The right to reject any and all bids, to waive any informalities in, or to make an award to other than the low bidder, should it be deemed to be in the best interest of the Town of Cheektowaga and in accordance with the law, are herewith reserved.

BY ORDER OF: THE TOWN BOARD OF THE TOWN OF CHEEKTOWAGA, COUNTY OF ERIE, STATE OF NEW YORK

Alice Magierski, Town Clerk

DATED: February 19, 2014

RESULT:	ADOPTED [UNANIMOUS]
MOVER:	Timothy J. Meyers, Councilmember
SECONDER:	Mary Holtz, Supervisor
AYES:	Holtz, Rogowski, Markel, Kaminski, Wozniak, Benczkowski, Meyers



9. RESOLUTION 2014-115

Negative SEQR Declaration- 2055 Walden Avenue

Sponsored By: Councilmember Meyers, Councilmember Markel

WHEREAS, pursuant to the Environmental Impact Review Ordinance of the Town of Cheektowaga, the Environmental Advisory Committee ("EAC") reviews various applications for site plans, rezonings, special permits, etc. and renders its recommendation concerning the environmental significance of such application, AND

WHEREAS, the Town Board, pursuant to the Environmental Impact Review Ordinance of the Town of Cheektowaga, is designated the Lead Agency in most instances, AND

WHEREAS, since the Town Board is the Lead Agency, it must affirm, modify or reject any recommendations submitted to it by the Advisory Committee, AND

WHEREAS, an application was submitted by Randall Benderson 1993-1 Trust for the construction of an 8,586 s.f. restaurant and an, 18,124 s.f. mixed use retail building at 2055 Walden Avenue, AND

WHEREAS, the Environmental Advisory Committee at its meetings held on February 5, 2014 recommended a determination of non-significance as shown on the attached memorandum dated February 6, 2014, AND

WHEREAS, the Town of Cheektowaga Planning Board recommended approval of the site plan at their meeting of February 13, 2014, AND

WHEREAS, the Town of Cheektowaga Traffic Safety Commission has reviewed the subject project and is recommending its approval, AND

WHEREAS, this Town Board has reviewed the application submitted and the recommendations made by the Environmental Advisory Committee, the Planning Board and the Traffic Safety Commission, NOW, THEREFORE, BE IT

RESOLVED, that this Town Board determines that the project will not have a significant effect on the environment and therefore issues a Negative Declaration for purposes of the State Environmental Quality Review Act (SEQRA).

Attachments:

SITE PLAN WITH LANDSCAPING 2-6-2014 (PDF)

RESULT:	ADOPTED [UNANIMOUS]
MOVER:	Timothy J. Meyers, Councilmember
SECONDER:	Charles Markel, Councilmember
AYES:	Holtz, Rogowski, Markel, Kaminski, Wozniak, Benczkowski, Meyers



10. RESOLUTION 2014-116

Negative SEQR Declaration -3381 Genesee Street

Sponsored By: Councilmember Meyers, Councilmember Markel

WHEREAS, pursuant to the Environmental Impact Review Ordinance of the Town of Cheektowaga, the Environmental Advisory Committee ("EAC") reviews various applications for site plans, rezonings, special permits, etc. and renders its recommendation concerning the environmental significance of such application, AND

WHEREAS, the Town Board, pursuant to the Environmental Impact Review Ordinance of the Town of Cheektowaga, is designated the Lead Agency in most instances, AND

WHEREAS, since the Town Board is the Lead Agency, it must affirm, modify or reject any recommendations submitted to it by the Advisory Committee, AND

WHEREAS, an application was submitted by Patricia M. Krall-Dwyer for the conversion of an existing dwelling into an administrative office/training facility with an accessory apartment at 3381 Genesee Street, AND

WHEREAS, the Environmental Advisory Committee at its meetings held on February 5, 2013 recommended a determination of non-significance as shown on the attached memorandum dated February 6, 2014, AND

WHEREAS, the Town of Cheektowaga Planning Board recommended approval of the site plan at their meeting of February 13, 2014, AND

WHEREAS, the Town of Cheektowaga Traffic Safety Commission has reviewed the subject project and is recommending its approval, AND

WHEREAS, this Town Board has reviewed the application submitted and the recommendations made by the Environmental Advisory Committee, the Planning Board and the Traffic Safety Commission NOW, THEREFORE, BE IT

RESOLVED, that this Town Board determines that the project will not have a significant effect on the environment and therefore issues a Negative Declaration for purposes of the State Environmental Quality Review Act (SEQRA).

RESULT:	ADOPTED [UNANIMOUS]
MOVER:	Timothy J. Meyers, Councilmember
SECONDER:	Charles Markel, Councilmember
AYES:	Holtz, Rogowski, Markel, Kaminski, Wozniak, Benczkowski, Meyers



11. RESOLUTION 2014-117

Accept Site Plan- 2055 Walden Avenue

Sponsored By: Councilmember Markel, Councilmember Rogowski

WHEREAS, pursuant to the Zoning Law of the Town of Cheektowaga, the Planning Board reviews various development review applications for site plans, rezonings, special permits and realty subdivisions and renders its recommendation concerning the compatibility of such application with the zoning regulations, the Town Master Plan and neighborhood character, AND

WHEREAS, the Town Board, pursuant to section 260-47.1C of the Zoning Law of the Town of Cheektowaga is vested with the authority to approve site plans and modify or reject any recommendation submitted to it by its advisory committees, AND

WHEREAS, Randall Benderson 1993-1 Trust submitted a development review application for the construction of an 8,586 s.f. restaurant and an, 18,124 s.f. mixed use retail building at 2055 Walden Avenue, AND

WHEREAS, the Town of Cheektowaga Planning Board, reviewed and commented on the Application at their meeting of February 13, 2014 and have recommended approval thereof, NOW THEREFORE BE IT,

RESOLVED, that pursuant to Section 260-47-1 of the Code of the Town of Cheektowaga and Section 274-a of New York State Town Law that this Town Board approves the proposed site plan subject to:

1. The Town Engineer reviewing and approving the drainage /grading plan.

Attachments:

SITE PLAN WITH LANDSCAPING 2-6-2014 (PDF)

RESULT:	ADOPTED [UNANIMOUS]
MOVER:	Charles Markel, Councilmember
SECONDER:	James P. Rogowski, Councilmember
AYES:	Holtz, Rogowski, Markel, Kaminski, Wozniak, Benczkowski, Meyers



12. RESOLUTION 2014-118

Accept Site Plan- 3381 Genesee Street

Sponsored By: Councilmember Markel, Councilmember Rogowski

WHEREAS, pursuant to the Zoning Law of the Town of Cheektowaga, the Planning Board reviews various development review applications for site plans, rezonings, special permits and realty subdivisions and renders its recommendation concerning the compatibility of such application with the zoning regulations, the Town Master Plan and neighborhood character, AND

WHEREAS, the Town Board, pursuant to section 260-47.1C of the Zoning Law of the Town of Cheektowaga is vested with the authority to approve site plans and modify or reject any recommendation submitted to it by its advisory committees, AND

WHEREAS, Patricia Krall-Dwyer submitted a development review application for the conversion of an existing dwelling into an administrative office/training facility with an accessory apartment at 3381 Genesee Street, AND

WHEREAS, the Town of Cheektowaga Planning Board, reviewed and commented on the Application at their meeting of February 13, 2014 and have recommended approval thereof, NOW THEREFORE BE IT,

RESOLVED, that pursuant to Section 260-47-1 of the Code of the Town of Cheektowaga and Section 274-a of New York State Town Law that this Town Board approves the proposed site plan subject to:

1. The Town Engineer reviewing /approving the drainage/grading plan.

Attachments:

Site Plan (PDF)

RESULT:	ADOPTED [UNANIMOUS]
MOVER:	Charles Markel, Councilmember
SECONDER:	James P. Rogowski, Councilmember
AYES:	Holtz, Rogowski, Markel, Kaminski, Wozniak, Benczkowski, Meyers



13. RESOLUTION 2014-119

Authorize Purchase of Copy Machine for Records Center

Sponsored By: Supervisor Holtz, Councilmember Benczkowski

WHEREAS, due to heavy usage and age, a copy machine in the Records Center is experiencing many breakdowns requiring frequent service calls and maintenance; and

WHEREAS, Erie 1 Board of Cooperative Educational Services ("BOCES") solicited bids for the purchase of photocopiers for use by them, school districts and municipalities in the Western New York area; and

WHEREAS, the New York State General Municipal Law, Section 103, authorizes the purchase by the Town of said photocopiers under contracts let by any other agency of the State, provided said contract was let in a manner that constituted competitive bidding consistent with State Law, and further that provision was made in the bid documents enabling municipalities to utilize said bid award, thereby eliminating the need for competitive bidding by the Town thus allowing "piggybacking" off the BOCES' bid; and

WHEREAS, the BOCES' bid documents and award contained such provisions; and

WHEREAS, a local vendor, Eagle Systems, Inc., was a successful bidder and was awarded the bid by BOCES (BOCES Bid #CE060713C) and is an authorized dealer for Toshiba copiers under said contract; and

WHEREAS, the Town of Cheektowaga solicited a quotation from Eagle Systems to purchase a copy machine for the Records Center; NOW, THEREFORE, BE IT

RESOLVED, that this Town Board agrees to purchase a Toshiba eStudio 3055c copy machine through the contract awarded by Erie 1 Board of Cooperative Educational Services ("BOCES"), Bid #CE060713C, utilizing a local vendor/authorized dealer, Eagle Systems, Inc., 2421 Harlem Road, Cheektowaga, New York 14225, at a total cost not to exceed \$4,552.00, said cost including delivery, surge protector, installation on servers or workstations, and removal and return of the hard drive on the present copier to the Town of Cheektowaga for destruction; and BE IT FURTHER

RESOLVED, that the cost per copy for maintenance and supplies for said copier for a guaranteed two-year period, commencing on the date of installation of said copier, will be \$0.008 per black and white copy and \$0.06 per color copy; and BE IT FURTHER

RESOLVED, that moneys for said purchase shall be appropriated from equipment line items in said department's budget; and BE IT FURTHER

RESOLVED, that the Supervisor be and hereby is authorized and directed to execute all documents and maintenance agreements with Eagle Systems, Inc., to effectuate the purchase subject to the review and approval of same by the Town Attorney.

RESULT: **ADOPTED [UNANIMOUS]**
MOVER: Mary Holtz, Supervisor
SECONDER: Diane Benczkowski, Councilmember
AYES: Holtz, Rogowski, Markel, Kaminski, Wozniak, Benczkowski, Meyers



14. RESOLUTION 2014-120

Approval of Public Improvement Permit for the Installation of Curbing at 83 Anderson Road

Sponsored By: Councilmember Kaminski, Councilmember Markel

WHEREAS, Kabir's LLC, as part of the development of a project at #83 Anderson Road, has submitted a Public Improvement Permit Application, plans and specifications, and permit fee for the installation of approximately 300 L.F. of curbing fronting its parcel within the Anderson Road highway right-of-way, the design of which is acceptable to the Town Highway Superintendent and Town Engineer as detailed on design drawings prepared by Optima Design and Engineering PLLC, NOW, THEREFORE, BE IT

RESOLVED, that the Public Improvement Permit be and hereby is approved for the aforesaid curb installation project, AND, BE IT FURTHER

RESOLVED, that the permit fee in the amount of \$288.00 shall be deposited in the Public Improvement Permit Account established for the receipt and disbursement of such fees.

RESULT:	ADOPTED [UNANIMOUS]
MOVER:	Gerald Kaminski, Councilmember
SECONDER:	Charles Markel, Councilmember
AYES:	Holtz, Rogowski, Markel, Kaminski, Wozniak, Benczkowski, Meyers



15. RESOLUTION 2014-121

Agreement with Public Library

Sponsored By: Councilmember Wozniak, Councilmember Rogowski

WHEREAS, the Cheektowaga Department of Youth and Recreational Services is desirous of continuing the operation of a joint program with the Cheektowaga Public Library System at Cheektowaga's two branch libraries, to provides special activities that encourage children to read and become more familiar with the library, and

WHEREAS, said program is open to all Cheektowaga youth regardless of race, color or creed, NOW, THEREFORE, BE IT

RESOLVED that the Supervisor be and hereby is authorized to execute an agreement between the Town of Cheektowaga and the Cheektowaga Public Library System to continue said program for a twelve (12) month period, January 1, 2014 through December 31, 2014 with a total cost not to exceed \$2,200.00.

CONTRACT # (BUDGET LINE ITEM) 01-7310-4675

RESULT:	ADOPTED [UNANIMOUS]
MOVER:	Angela M. Wozniak, Councilmember
SECONDER:	James P. Rogowski, Councilmember
AYES:	Holtz, Rogowski, Markel, Kaminski, Wozniak, Benczkowski, Meyers



16. RESOLUTION 2014-122

Agreement with Catholic Charities (YES)

Sponsored By: Councilmember Wozniak, Councilmember Rogowski

WHEREAS, the Cheektowaga Department of Youth and Recreational Services is desirous of continuing the operation of the Youth Engaged in Service (Y.E.S.) program with Catholic Charities of Buffalo Metropolitan Services Department, 525 Washington Street, Buffalo, New York, AND

WHEREAS, said program, which prepares and provides teenagers with opportunities to assist their community in various projects that have a need for volunteers and is open to all Cheektowaga youth regardless of race, color, or creed, NOW, THEREFORE, BE IT

RESOLVED that the Supervisor of the Town of Cheektowaga be and hereby is directed to execute an agreement between the Town of Cheektowaga and Catholic Charities of Buffalo Metropolitan Services Department to continue said program for a twelve month period, January 1, 2014 through December 31, 2014 with a total payment to Catholic Charities not to exceed the sum of \$56,040.00 and the New York State Office of Children and Family services will reimburse the Town \$35,891.35 leaving the actual cost to the Town at \$20,148.65.

CONTRACT # (BUDGET LINE ITEM) 01-7310-4685

RESULT:	ADOPTED [UNANIMOUS]
MOVER:	Angela M. Wozniak, Councilmember
SECONDER:	James P. Rogowski, Councilmember
AYES:	Holtz, Rogowski, Markel, Kaminski, Wozniak, Benczkowski, Meyers



17. RESOLUTION 2014-123

Agreement with Catholic Charities (SIS)

Sponsored By: Councilmember Wozniak, Councilmember Rogowski

WHEREAS, the Cheektowaga Department of Youth and Recreational Services is desirous of continuing the operation of a joint program with Catholic Charities of Buffalo Metropolitan Services Department, 525 Washington Street, Buffalo, New York, 14203, whereby high risk youth within the Town will receive individual and family counseling through the School Intervention Service, AND

WHEREAS, said program is open to all Cheektowaga youth regardless of race, color, or creed, NOW, THEREFORE, BE IT

RESOLVED that the Supervisor of the Town of Cheektowaga be and hereby is directed to execute an agreement between the Town of Cheektowaga and Catholic Charities Metropolitan Services Department, to continue said program for a twelve month period, January 1, 2014 through December 31, 2014 with a total cost not to exceed the sum of \$176,845.00 and BE IT FURTHER

RESOLVED that Catholic Charities Metropolitan Services will reimburse the Town \$35,900.00 of the total budget for said program leaving the actual cost to the Town at \$140,945.00

CONTRACT # (BUDGET LINE ITEM) 01-7310-4677

RESULT:	ADOPTED [UNANIMOUS]
MOVER:	Angela M. Wozniak, Councilmember
SECONDER:	James P. Rogowski, Councilmember
AYES:	Holtz, Rogowski, Markel, Kaminski, Wozniak, Benczkowski, Meyers



18. RESOLUTION 2014-124

Special Event - Infant of Prague Church 5k Run

Sponsored By: Councilmember Meyers, Councilmember Rogowski

WHEREAS, by resolution dated May 1, 1995, this Town Board adopted a Special Events policy, which requires anyone wishing to hold a special event in the Town to file an application and supporting documentation, fees, etc. to the Town Clerk prior to the special event, AND

WHEREAS, Infant of Prague Church has made application to hold its " 5K Race" on Saturday, April 5, 2014 beginning at 11:00 A.M. for approximately forty minutes along the following route: Foisset, Mapleview, Yeager, Union, Clearvale, Beach, Huth; AND

WHEREAS, this Board has reviewed the aforementioned application, which application has been approved by the Police Department and Highway Department and has no objection to same, AND

WHEREAS, due to the nature of the event, this Town Board hereby waives the following requirements:

- 1) Submittal of plan for sanitary facilities;
- 2) Submittal of site plan;
- 3) Requirement that application be made at least 60 days prior to the date of the special event;
- 4) Submittal of Security Plan;
- 5) Submittal of Fire Prevention/Emergency Services Plan; NOW, THEREFORE, BE

IT

RESOLVED, that this Town Board hereby approves the aforementioned application of Infant of Prague Church for the said 5K Race on Saturday, April 5, 2014 beginning at 11:00 a.m.; AND BE IT FURTHER

RESOLVED, that the Chief of Police be and hereby is directed to provide traffic safety and escort services for such run and to ensure compliance with Section 1600(a)(6) of the Vehicle and Traffic Law; AND BE IT FURTHER

RESOLVED, that the Town Clerk shall forward a copy of this resolution to the Chief of Police Dave Zack.

RESULT:	ADOPTED [UNANIMOUS]
MOVER:	Timothy J. Meyers, Councilmember
SECONDER:	James P. Rogowski, Councilmember
AYES:	Holtz, Rogowski, Markel, Kaminski, Wozniak, Benczkowski, Meyers



19. RESOLUTION 2014-125

Retain Wendel to Provide Professional Services for the Town's GIS System

Sponsored By: Supervisor Holtz, Councilmember Meyers

WHEREAS, the Town previously engaged the firm of Wendel to provide professional services to develop and support a web based GIS System including asset management and mapping tools for the Town's storm and sanitary sewer infrastructure for use by the Town Engineering, Sewer Maintenance and Highway Departments, AND

WHEREAS, the Town Engineer has recommended that Wendel be retained for 2014 in accordance with their proposal dated January 23, 2014 to provide hosting and maintenance services for the Town's web based GIS System to include annual updates of parcel information, aerial imagery and GPS data management, NOW, THEREFORE, BE IT

RESOLVED, that Wendel be and hereby is retained to provide the above referenced professional services at a cost not to exceed \$2,600.00, AND, BE IT FURTHER

RESOLVED, that the Supervisor be and hereby is authorized and directed to execute the professional services proposal with Wendel for the above services, AND, BE IT FURTHER

RESOLVED, that moneys for said services shall be appropriated from the Town-Wide Drainage District Account No. 400-8140-4581 in the amount of \$1,300.00 and the Consolidated Sanitary Sewer District Account No. 255-8125-4581 in the amount of \$1,300.00.

RESULT:	ADOPTED [UNANIMOUS]
MOVER:	Mary Holtz, Supervisor
SECONDER:	Timothy J. Meyers, Councilmember
AYES:	Holtz, Rogowski, Markel, Kaminski, Wozniak, Benczkowski, Meyers



20. RESOLUTION 2014-126

Authorization of Student Interns (Police Department)/Bridget A. Smith, Jonathan R. Tirado, John O'Donnell, Brittany Yasow

Sponsored By: Councilmember Kaminski, Supervisor Holtz

WHEREAS, Bridget A. Smith of Buffalo, New York (a student at Medaille College), Jonathan R. Tirado of Cheektowaga, New York (a student at Medaille College), John O'Donnell of Cheektowaga, New York (a student at Bryant & Stratton College) and Brittany Yasow of Buffalo, New York (a student at Erie Community College), have requested to participate in the student internship program at the Police Department; AND

WHEREAS, these individuals have been interviewed by the Police Department and the Police Department is willing to afford them the opportunity to intern in the Police Department; NOW, THEREFORE, BE IT

RESOLVED, that Bridget A. Smith of Buffalo, New York, Jonathan R. Tirado of Cheektowaga, New York, John O'Donnell of Cheektowaga, New York and Brittany Yasow of Buffalo, New York, be and hereby are authorized to participate as unpaid interns in the Police Department, subject to their execution of a Waiver of Liability and Agreement of Confidentiality; AND, BE IT FURTHER

RESOLVED, that their internships be and hereby are effective February 20, 2014 through May 31, 2014; AND, BE IT FURTHER

RESOLVED, that the Town Supervisor be and hereby is authorized and directed to execute the Agreement of Confidentiality, and all other documents necessary to effectuate these student's internships in the Police Department.

RESULT:	ADOPTED [UNANIMOUS]
MOVER:	Gerald Kaminski, Councilmember
SECONDER:	Mary Holtz, Supervisor
AYES:	Holtz, Rogowski, Markel, Kaminski, Wozniak, Benczkowski, Meyers



21. RESOLUTION 2014-127

Youth & Recreation Termination

Sponsored By: Councilmember Wozniak, Councilmember Rogowski

BE IT RESOLVED that the individuals listed below be and herby are terminated in the Department of Youth & Recreational Services effective as indicated:

Timothy Baumgart	Never worked	14225
Kelly Mayer	Never worked	14225
Randall Szymkowiak	8/28/13	14227
Nicholas Schuler	Never Worked	14227
Aaron Tymorek	12/15/13	14225
Jacqueline Tymorek	12/15/13	14225

Motion by Councilmember Rogowski; seconded by Councilmember Benczkowski to waive the reading of names for the following two (2) resolutions: 2014-127 and 2014-128. Motion carried.

RESULT: **ADOPTED [UNANIMOUS]**
MOVER: Angela M. Wozniak, Councilmember
SECONDER: James P. Rogowski, Councilmember
AYES: Holtz, Rogowski, Markel, Kaminski, Wozniak, Benczkowski, Meyers



22. RESOLUTION 2014-128

Hiring/Termination of Part Time/Seasonal Employees

Sponsored By: Councilmember Kaminski, Supervisor Holtz

BE IT RESOLVED, that the following individuals be and hereby are hired as PART-TIME EMPLOYEES in the departments listed, not to exceed nineteen (19) hours on a weekly basis, in compliance with Civil Service Laws and Regulations as well as the provisions of the Town's collective bargaining agreement between the Town of Cheektowaga and the Town of Cheektowaga Employees Association:

POLICE DEPARTMENT Police Attendant \$15.00/hour effective 2/20/14
Rachel L. Kandefor, Cheektowaga, New York

BE IT RESOLVED, that the following individuals be and hereby are hired as **SEASONAL EMPLOYEES**, not to exceed five (5) months in a calendar year, in the various departments listed and in compliance with Civil Service Laws and Regulations as well as the provisions of the Town's collective bargaining agreement between the Town of Cheektowaga and the Town of Cheektowaga Employees Association:

FACILITIES DEPARTMENT (Buildings and Grounds) Laborer \$8.50/hour effective 2/20/14
Tyler M. Pocobello, Cheektowaga, New York

BE IT RESOLVED, that the following seasonal and/or part-time employees be and hereby are terminated as listed:

TOWN CLERK'S OFFICE
Chelsea A. Dawe effective 2/20/14

BE IT FURTHER RESOLVED, that the following salaries be amended as listed:

TOWN CLERK'S OFFICE Clerk \$11.00/hour effective 2/10/14
Melissa A. Dabb, Depew, New York

TOWN CLERK'S OFFICE Clerk \$10.00/hour effective 2/20/14
Patricia M. Miller, Cheektowaga, New York
Nancy A. Paner, Depew, New York

ASSESSOR'S OFFICE Clerk \$9.00 effective 1/1/14
Kristen M. Murphy, Sloan, New York
Paula R. Murphy, Sloan, New York
Kimberly D. Gervase, Depew, New York
Kara N. Oxley, Cheektowaga, New York

HIGHWAY DEPARTMENT Clerk \$9.25/hour effective 1/1/14
Genevieve Fronczak, Cheektowaga, New York
Leeann Stachura, Depew, New York

HIGHWAY DEPARTMENT Laborer \$9.25/hour effective 1/1/14
Jacob R. Havernick, Cheektowaga, New York

RESULT:	ADOPTED [UNANIMOUS]
MOVER:	Gerald Kaminski, Councilmember
SECONDER:	Mary Holtz, Supervisor
AYES:	Holtz, Rogowski, Markel, Kaminski, Wozniak, Benczkowski, Meyers



23. RESOLUTION 2014-129

Appointment of Senior Engineering Assistant (Engineering Department) (Competitive/Permanent) (Gail A. Milburth)

Sponsored By: Councilmember Kaminski, Supervisor Holtz

WHEREAS, Gail A. Milburth was appointed provisionally by this Town Board to the position of Senior Engineering Assistant in the Engineering Department effective March 28, 2011; AND

WHEREAS, a list has been established by Erie County Civil Service for said title; AND

WHEREAS, Ms. Milburth is eligible for permanent appointment; NOW, THEREFORE, BE IT

RESOLVED, that Gail A. Milburth of Cheektowaga, New York, be and hereby is appointed to the permanent position of Senior Engineering Assistant in the Engineering Department effective February 20, 2014.

RESULT:	ADOPTED [UNANIMOUS]
MOVER:	Gerald Kaminski, Councilmember
SECONDER:	Mary Holtz, Supervisor
AYES:	Holtz, Rogowski, Markel, Kaminski, Wozniak, Benczkowski, Meyers



24. RESOLUTION 2014-130

Travel Authorization Youth & Recreational Services/Recreation Supervisor Lynn Koszuta

Sponsored By: Councilmember Kaminski, Supervisor Holtz

WHEREAS, the New York State Recreation and Park Society 74th Annual Conference is being held March 23-25, 2014 in Saratoga Springs, New York; AND

WHEREAS, Recreation Supervisor Lynn Koszuta has been recommended to attend said training; AND

WHEREAS, Executive Director of Youth and Recreation Ellen Fischer has submitted a request for travel authorization along with the proper paperwork in a timely manner; AND

WHEREAS, the total cost to the Town shall not exceed \$942.00; AND

WHEREAS, these expenses have been budgeted by the Department; NOW, THEREFORE, BE IT

RESOLVED, that Recreation Supervisor Lynn Koszuta be and hereby is authorized to attend the New York State Recreation and Park Society 74th Annual Conference being held March 23-25, 2014 in Saratoga Springs, New York.

RESULT:	ADOPTED [UNANIMOUS]
MOVER:	Gerald Kaminski, Councilmember
SECONDER:	Mary Holtz, Supervisor
AYES:	Holtz, Rogowski, Markel, Kaminski, Wozniak, Benczkowski, Meyers



25. RESOLUTION 2014-131

Travel Authorization Police Department/Police Officer Michael McDonough, Scott Scharlau

Sponsored By: Councilmember Kaminski, Supervisor Holtz

WHEREAS, the New York State Truck Safety and Education Symposium and Safety Exhibition is being held March 25-26, 2014 in Albany, New York; AND

WHEREAS, Police Officers Michael McDonough and Scott Scharlau have been recommended to attend said training; AND

WHEREAS, Chief David Zack has submitted a request for travel authorization along with the proper paperwork in a timely manner; AND

WHEREAS, the total cost to the Town shall not exceed \$836.00; AND

WHEREAS, these expenses have been budgeted by the Department; NOW, THEREFORE, BE IT

RESOLVED, that Police Officers Michael McDonough and Scott Scharlau be and hereby are authorized to attend the New York State Truck Safety and Education Symposium and Safety Exhibition being held March 25-26, 2014 in Albany, New York.

RESULT:	ADOPTED [UNANIMOUS]
MOVER:	Gerald Kaminski, Councilmember
SECONDER:	Mary Holtz, Supervisor
AYES:	Holtz, Rogowski, Markel, Kaminski, Wozniak, Benczkowski, Meyers



26. RESOLUTION 2014-132

Travel Authorization Police Department/Public Safety Dispatchers John Charvat, Robert Rackl

Sponsored By: Councilmember Kaminski, Supervisor Holtz

WHEREAS, Navigator 2014 is being held April 30 - May 2, 2014 in Orlando, Florida;
AND

WHEREAS, Public Safety Dispatchers John Charvat and Robert Rackl have been recommended to attend said training; AND

WHEREAS, Chief David Zack has submitted a request for travel authorization along with the proper paperwork in a timely manner; AND

WHEREAS, the total cost to the Town shall not exceed \$2,187.00; AND

WHEREAS, these expenses have been budgeted by the Department; NOW,
THEREFORE, BE IT

RESOLVED, that Public Safety Dispatchers John Charvat and Robert Rackl be and hereby are authorized to attend Navigator 2014 being held April 30 - May 2, 2014 in Orlando, Florida.

RESULT:	ADOPTED [UNANIMOUS]
MOVER:	Gerald Kaminski, Councilmember
SECONDER:	Mary Holtz, Supervisor
AYES:	Holtz, Rogowski, Markel, Kaminski, Wozniak, Benczkowski, Meyers



27. RESOLUTION 2014-133

Travel Authorization Police Department/Police Officers James Rottger, Jacob Gawronski, Jonathan Ober, Thomas Rogers, Kurt Spieler

Sponsored By: Councilmember Kaminski, Supervisor Holtz

WHEREAS, the International Law Enforcement Educators and Trainers Association Annual Conference is being held March 23-29, 2014 in Lombard, Illinois; AND

WHEREAS, Police Officers James Rottger, Jacob Gawronski, Jonathan Ober, Thomas Rogers and Kurt Spieler have been recommended to attend said training; AND

WHEREAS, Chief David Zack has submitted a request for travel authorization along with the proper paperwork in a timely manner; AND

WHEREAS, the total cost to the Town shall not exceed \$5,334.00; AND

WHEREAS, these expenses have been budgeted by the Department; NOW, THEREFORE, BE IT

RESOLVED, that Police Officers James Rottger, Jacob Gawronski, Jonathan Ober, Thomas Rogers and Kurt Spieler be and hereby are authorized to attend the International Law Enforcement Educators and Trainers Association Annual Conference being held March 23-29, 2014 in Lombard, Illinois.

RESULT:	ADOPTED [UNANIMOUS]
MOVER:	Gerald Kaminski, Councilmember
SECONDER:	Mary Holtz, Supervisor
AYES:	Holtz, Rogowski, Markel, Kaminski, Wozniak, Benczkowski, Meyers

VI. Suspension of Rules

Motion by Councilmember Markel; seconded by Councilmember Rogowski to waive the Rules to Include the following Four (4) Resolutions: 2014-134; 2014-135; 2014-136 and 2014-137. Motion Carried.



1. RESOLUTION 2014-134

Award of Bid - One Used Fork Lift (Bid #2014-4)

Sponsored By: Councilmember Kaminski, Supervisor Holtz

WHEREAS, a Notice to Bidders was duly published for the receipt of bids for the furnishing of one (1) used Fork Lift for use by the Central Garage, which bids were duly received and opened by the Office of the Town Clerk at a public bid opening on February 5, 2014, AND

WHEREAS, said bids were referred to the Town Engineer for analysis, tabulation and report, AND

WHEREAS, said report recommends that the bid for the furnishing of one (1) used Fork Lift be awarded to E.D. Farrell Company, Inc. for their bid proposal, being the lowest bid meeting the requirements of the specifications, NOW, THEREFORE, BE IT

RESOLVED, that the bid for the furnishing of one (1) used Fork Lift is hereby awarded to:

E.D. Farrell Company, Inc.
105 Empire Drive
West Seneca, New York 14224

for their bid in the amount of \$18,300.00 which shall be chargeable to Account No:100-1640-2502.

RESULT:	ADOPTED [UNANIMOUS]
MOVER:	Gerald Kaminski, Councilmember
SECONDER:	Mary Holtz, Supervisor
AYES:	Holtz, Rogowski, Markel, Kaminski, Wozniak, Benczkowski, Meyers



2. RESOLUTION 2014-135

Award of Bid - 2014 Chevrolet Tahoes (Bid 2014-8)

Sponsored By: Councilmember Benczkowski, Councilmember Kaminski

WHEREAS, a Notice to Bidders was duly published for the receipt of bids for the furnishing of Two (2) New and Unused 2014 Chevrolet Tahoe 4WD 4-door LS Vehicles (or Equivalent); for the Police Department and, which bids were duly received and opened at a public bid opening called for that purpose, AND,

WHEREAS, said bids were referred to the Police Department for analysis and tabulation, NOW, THEREFORE, BE IT

RESOLVED, that the contract for the furnishing of Two (2) New and Unused 2014 Chevrolet Tahoe 4WD 4-door LS Vehicles (or Equivalent) be awarded to Joe Basil Chevrolet Inc., 5111 Transit Road, Depew, NY 14043, with said vendor meeting all set bidding conditions of the specifications, AND, BE IT

RESOLVED, that the purchase price will be \$72,258.00, AND, BE IT FURTHER

RESOLVED, that funds are available and will be procured from the Police Vehicle Line 100-3120-2303.

RESULT:	ADOPTED [UNANIMOUS]
MOVER:	Diane Benczkowski, Councilmember
SECONDER:	Gerald Kaminski, Councilmember
AYES:	Holtz, Rogowski, Markel, Kaminski, Wozniak, Benczkowski, Meyers



3. RESOLUTION 2014-136

Award Contract for Removal of Snow & Ice on Various Town-Owned Properties in the Town of Cheektowaga

Sponsored By: Councilmember Markel, Supervisor Holtz

WHEREAS, the Town of Cheektowaga Office Neighborhood Preservation has been requested to procure snow and ice removal services for sidewalks on ten specified non-governmental properties owned by the Town of Cheektowaga; And

WHEREAS, in accordance with the Procurement Policy of the Town of Cheektowaga, the Office Neighborhood Preservation issued a verbal/fax request for Bidders for Furnishing Equipment and Operators for the Removal of Snow & Ice on Various Town-Owned Properties for the Year 2014; And

WHEREAS, responses to said request were referred to the Director of Community Development and Town Attorney for analysis, tabulation and report; and

WHEREAS, based on the proposals submitted, the Director of Community Development has recommended that this Town Board award the contract to K.A.P. Landscaping and Snowplowing LLC, for its submission of a proposal to perform said services; NOW, THEREFORE, BE IT

RESOLVED, that the contract for Furnishing Equipment and Operators for the Removal of Snow & Ice on Various Properties in the Town of Cheektowaga for the Year 2014 be awarded to K.A.P. Landscaping and Snowplowing LLC, 11 Wellworth Place, Cheektowaga, New York, 14225, for the prices listed in its proposal, said amount being the lowest responsible bid meeting the requirements of the specifications for said services; and BE IT FURTHER

RESOLVED, that the Supervisor be and hereby is directed and authorized to execute a contract with K.A.P. Landscaping and Snowplowing LLC for the aforesaid services, subject to approval by the Town Attorney.

RESULT:	ADOPTED [UNANIMOUS]
MOVER:	Charles Markel, Councilmember
SECONDER:	Mary Holtz, Supervisor
AYES:	Holtz, Rogowski, Markel, Kaminski, Wozniak, Benczkowski, Meyers



4. RESOLUTION 2014-137

Authorize Purchase of Vehicles for Police Department

Sponsored By: Councilmember Benczkowski, Councilmember Kaminski

WHEREAS, the Police Department has requested authorization to purchase six (6) 2014 Ford AWD, 4-door police vehicles; AND

WHEREAS, DeLacy Ford is an authorized dealer of said vehicles under New York State Contract No. PC64893; AND

WHEREAS, DeLacy Ford has submitted a proposal for the cost of said vehicles to the Town in the amount of \$159,306.00, said cost being New York State Contract pricing; AND

WHEREAS, funds for said purchase have been budgeted and are available from account number 100-3120-2303, NOW, THEREFORE, BE IT

RESOLVED, that this Town Board hereby approves the purchase of said vehicles above referenced for use by the Police Department from DeLacy Ford, 3061 Transit Road, Elma, New York 14059, for the sum of \$159,306.00; AND, BE IT FURTHER

RESOLVED, that the Supervisor be and hereby is authorized and directed to execute all documents required to effectuate the purchase of said vehicles; AND BE IT FURTHER

RESOLVED, that the funds for this purchase shall be appropriated from budget line item number 100-3120-2303.

RESULT:	ADOPTED [UNANIMOUS]
MOVER:	Diane Benczkowski, Councilmember
SECONDER:	Gerald Kaminski, Councilmember
AYES:	Holtz, Rogowski, Markel, Kaminski, Wozniak, Benczkowski, Meyers

VII. Communications

A. Departmental Communications

1. **Supervisor's Statement of Funds - December 2013**
2. **Minutes: Town Environmental Advisory Council - February 5, 2014**

B. General Communications

1. **Summons & Complaint: Buffalo Erie Niagara Land Improvement Corp. vs. Jacob Bullis & Etal Tax Foreclosure for Premises: 44A Windwood Court**
2. **Summons & Complaint: Buffalo Erie Niagara Land Improvement Corp. vs. Cherie A. Ksiaskiewicz & Etal Tax Foreclosure for Premises: 3048 William St.**
3. **Notice of Claim: Roy Marciniak vs. Town of Cheektowaga**
4. **Notice of Claim: Melissa Oryszak vs. Town of Cheektowaga**
5. **Notice of Claim: Erin E Davis vs. Town of Cheektowaga**

VIII. Comments***A. Supervisor's Comments******B. Councilmember's Comments******C. Public Comments*****IX. Adjournment**

Motion by Councilmember Rogowski; Seconded by Supervisor Holtz to adjourn the meeting at 7:40 PM.

Alice Magierski, Town Clerk

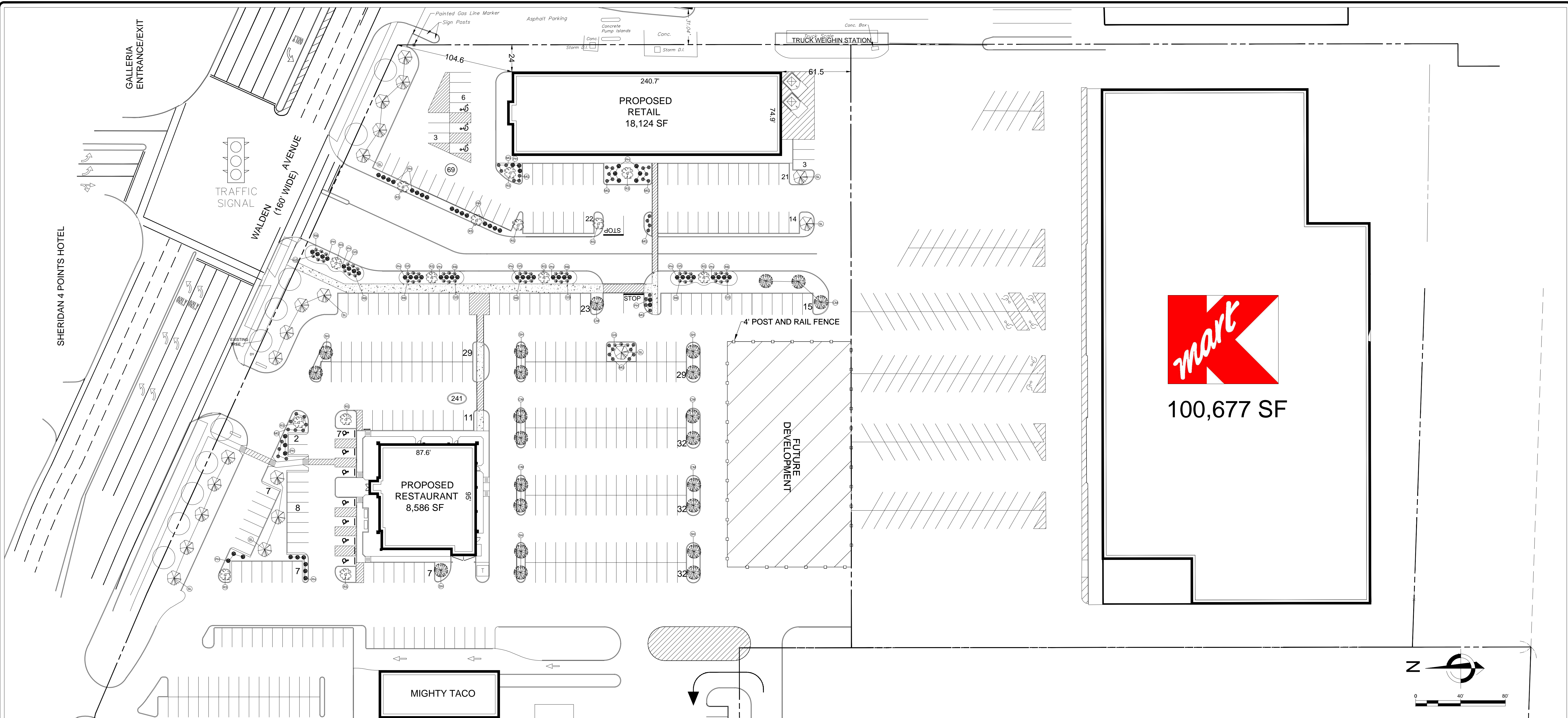

SITE AERIAL

ZONING MAP KEY PLAN

ZONING DATA					
ZONING	REQUIRED	PROVIDED	PARKING REQUIREMENTS	REQUIRED	PROVIDED
MINIMUM LOT WIDE	C	C	RESTAURANT (2 SPACES/ 5 SEATS)	158	
SITE ACREAGE	50'	536.66'	RETAIL (1 SPACE/ 300 SF)	61	
MAXIMUM BUILDING HEIGHT	30'	TBD	TOTAL	219	310
BUILDING SETBACKS			STALL SIZE	9' X 19'	9' X 19'
FRONT	50'	104.6'	OVERALL LANDSCAPED AREA	15%	18.6%
SIDE	10' *	24'	INTERIOR LANDSCAPED AREA	5%	9.2%
REAR	10'	61.5'	ADDITIONAL INFORMATION		
			* 30' REQUIRED IF THERE IS A DRIVE		
PARKING LOT SETBACKS					
FRONT	25'	25'			
SIDES	10'	0'			
REAR	10'	0'			

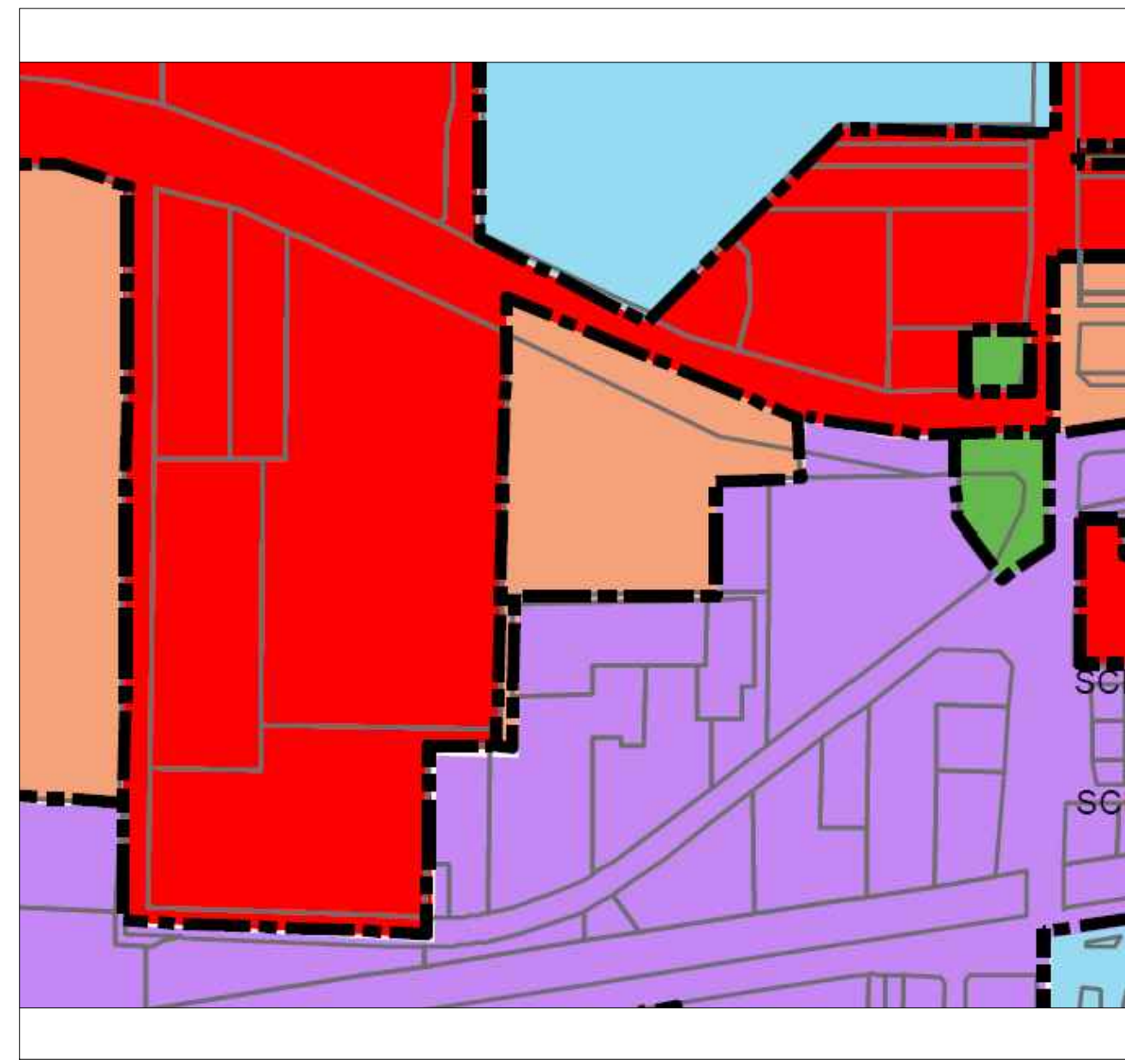

PLANT SCHEDULE				
KEY	BOTANICAL NAME	COMMON NAME	SIZE	QUANTITY
TREES				
RS	HIBISCUS SYRIACUS	ROSE SHARON STANDARD	#10	14
SL	SYRINGA RETICULATA	IVORY SILK LILAC	2"	20
SH	GLEDITSIA TRIACANTHOS INERMIS	SKYLINE HONEYLOCUST	2 1/2"	11
CM	ACER PLATANOIDES	CRIMSON SENTRY MAPLE	2 1/2"	12
SHRUBS				
RB	BERBERIS THUNBERGII	ROSY GLOW BARBERRY	#3	24
MG	MISCANTHUS SINESIS	MORNING LIGHT GRASS	#3	43
PH	ILEX CRENATA	SKY PENCIL HOLLY	#3	71
GS	SPIRAEA JAPONICA	GOLD MOUND SPIRAEA	#3	27

PROPOSED RETAIL-RESTUARANT
2055 WALDEN AVENUE
CHEEKTOWAGA, NY 14225

2130 PROPOSED SITE PLAN W/ LANDSCAPING 2-6-2014 FEBRUARY 6, 2014

BENDERSON DEVELOPMENT COMPANY, LLC
570 DELAWARE AVENUE, BUFFALO, NY 14202
Phone: (716) 886-0211 Fax: (716) 856-7791
www.benderson.com

PROPOSED SITE PLAN

DRAWN BY: DMN CHECKED BY: MAO SCALE: 1:40

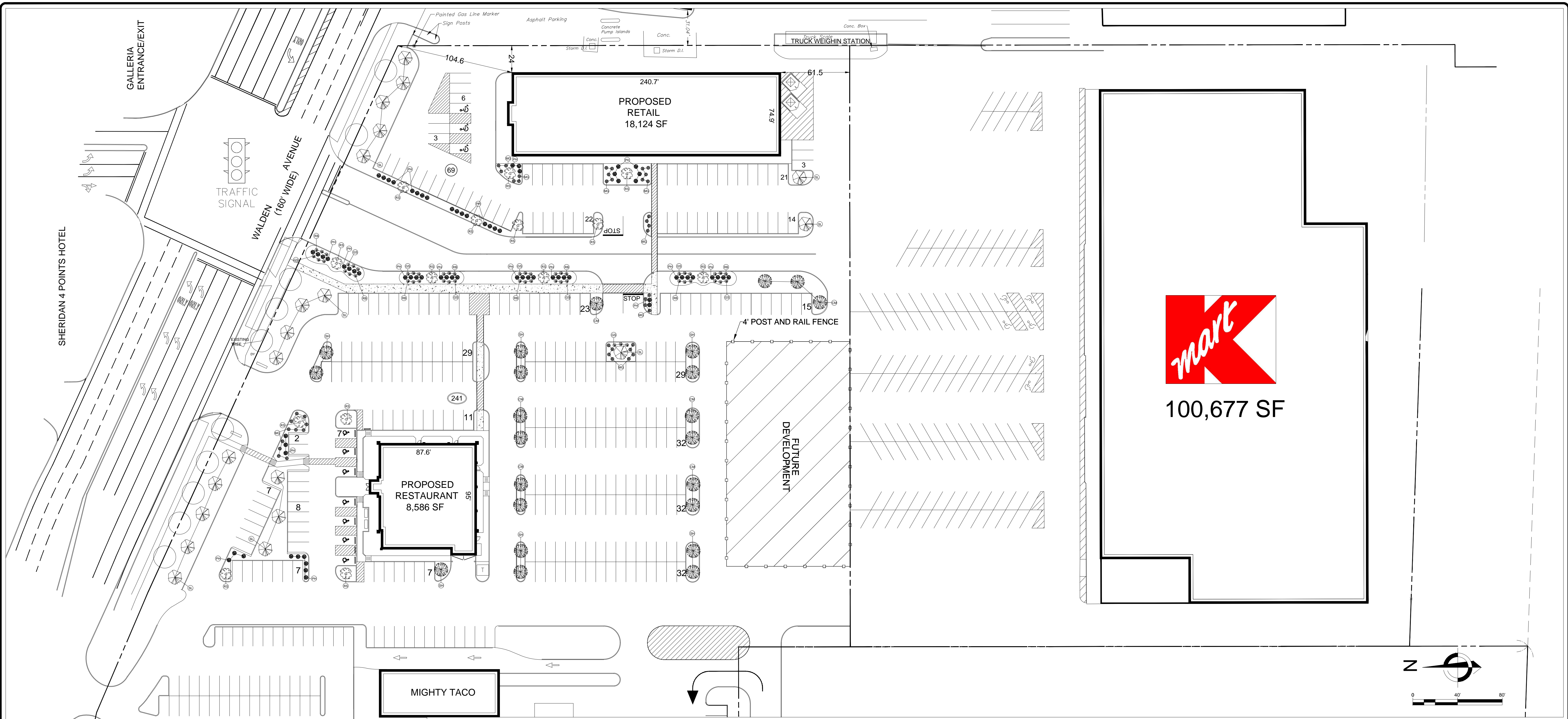

100,677 SF

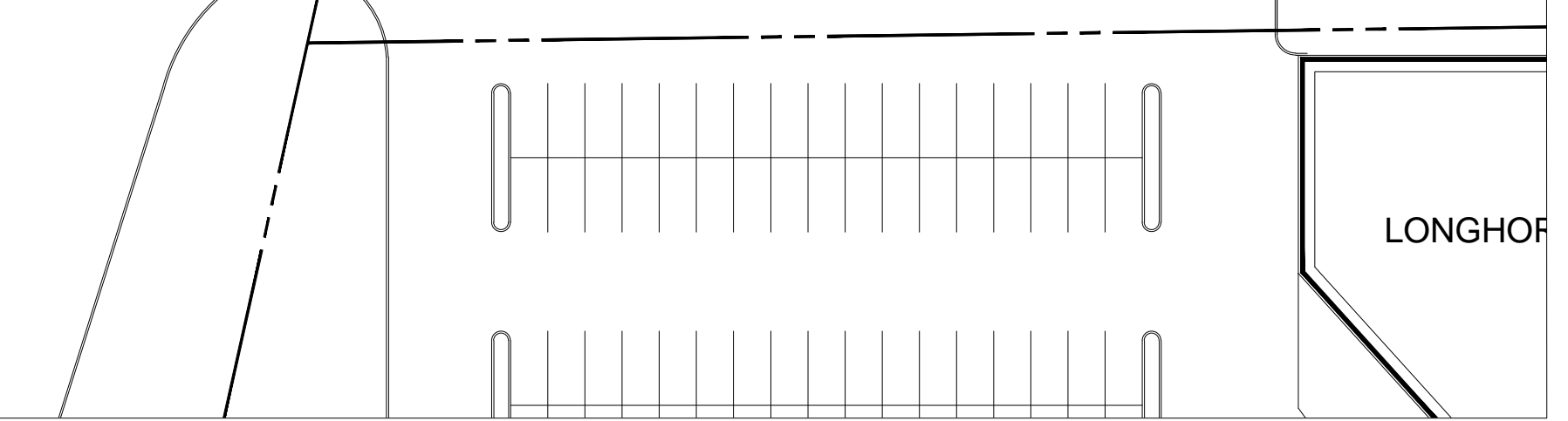
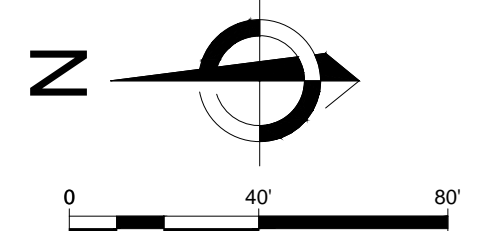

SITE AERIAL

ZONING MAP KEY PLAN

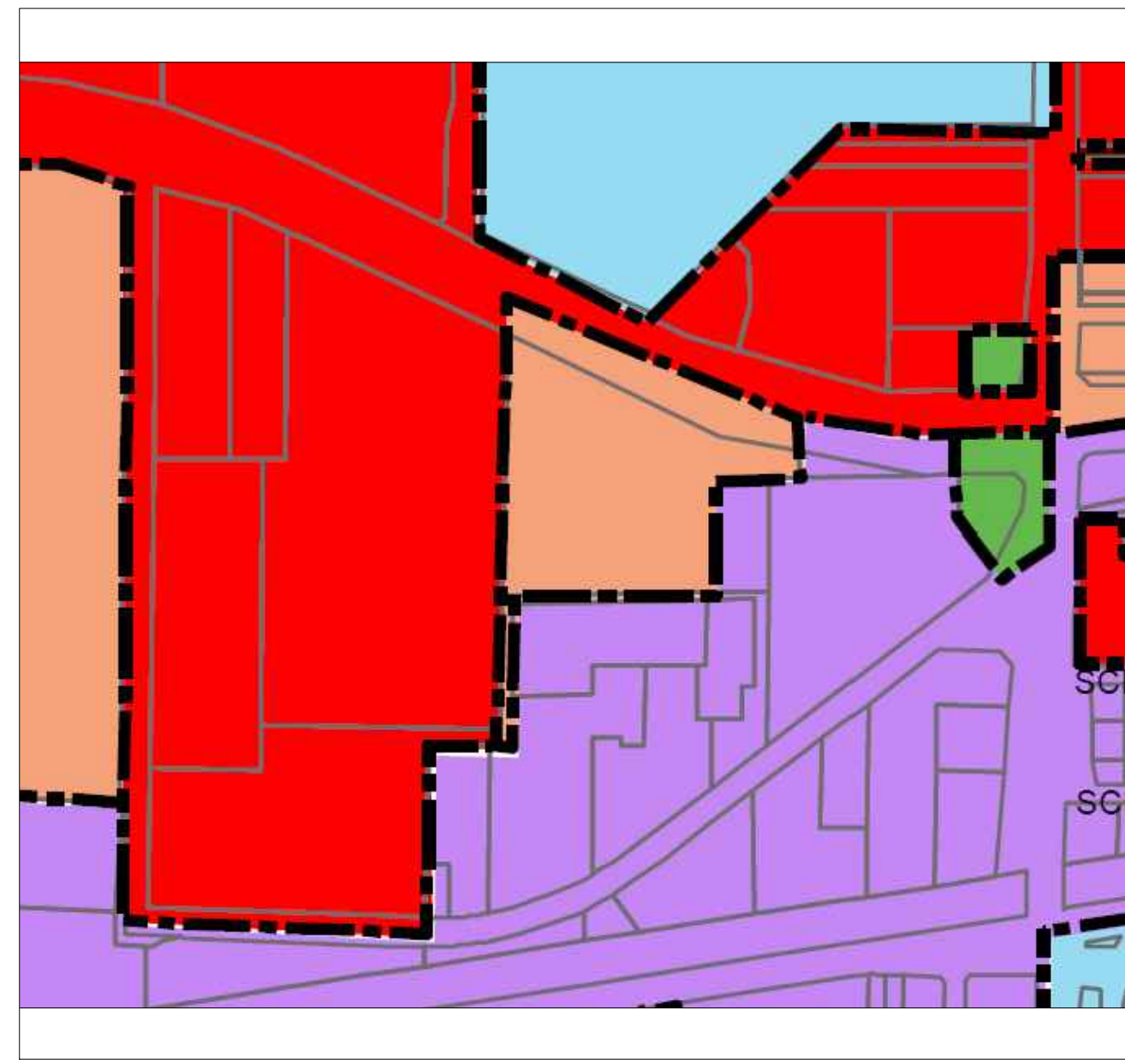

ZONING DATA					
ZONING	REQUIRED	PROVIDED	PARKING REQUIREMENTS	REQUIRED	PROVIDED
MINIMUM LOT WIDE	C	C	RESTAURANT (2 SPACES/ 5 SEATS)	158	
SITE ACREAGE	50'	536.66'	RETAIL (1 SPACE/ 300 SF)	61	
MAXIMUM BUILDING HEIGHT	30'	TBD	TOTAL	219	310
BUILDING SETBACKS			STALL SIZE	9' X 19'	9' X 19'
FRONT	50'	104.6'	OVERALL LANDSCAPED AREA	15%	18.6%
SIDE	10' *	24'	INTERIOR LANDSCAPED AREA	5%	9.2%
REAR	10'	61.5'	ADDITIONAL INFORMATION		
			* 30' REQUIRED IF THERE IS A DRIVE		
PARKING LOT SETBACKS					
FRONT	25'	25'			
SIDES	10'	0'			
REAR	10'	0'			

PLANT SCHEDULE				
KEY	BOTANICAL NAME	COMMON NAME	SIZE	QUANTITY
TREES				
RS	HIBISCUS SYRIACUS	ROSE SHARON STANDARD	#10	14
SL	SYRINGA RETICULATA	IVORY SILK LILAC	2"	20
SH	GLEDITSIA TRIACANTHOS INERMIS	SKYLINE HONEYLOCUST	2 1/2"	11
CM	ACER PLATANOIDES	CRIMSON SENTRY MAPLE	2 1/2"	12
SHRUBS				
RB	BERBERIS THUNBERGII	ROSY GLOW BARBERRY	#3	24
MG	MISCANTHUS SINESIS	MORNING LIGHT GRASS	#3	43
PH	ILEX CRENATA	SKY PENCIL HOLLY	#3	71
GS	SPIRAEA JAPONICA	GOLD MOUND SPIRAEA	#3	27

PROPOSED RETAIL-RESTUARANT
2055 WALDEN AVENUE
CHEEKTOWAGA, NY 14225

2130 PROPOSED SITE PLAN W/ LANDSCAPING 2-6-2014 FEBRUARY 6, 2014

570 DELAWARE AVENUE, BUFFALO, NY 14202
Phone: (716) 886-0211 Fax: (716) 856-7791
www.benderson.com

PROPOSED SITE PLAN

DRAWN BY: DMN CHECKED BY: MAO SCALE: 1:40

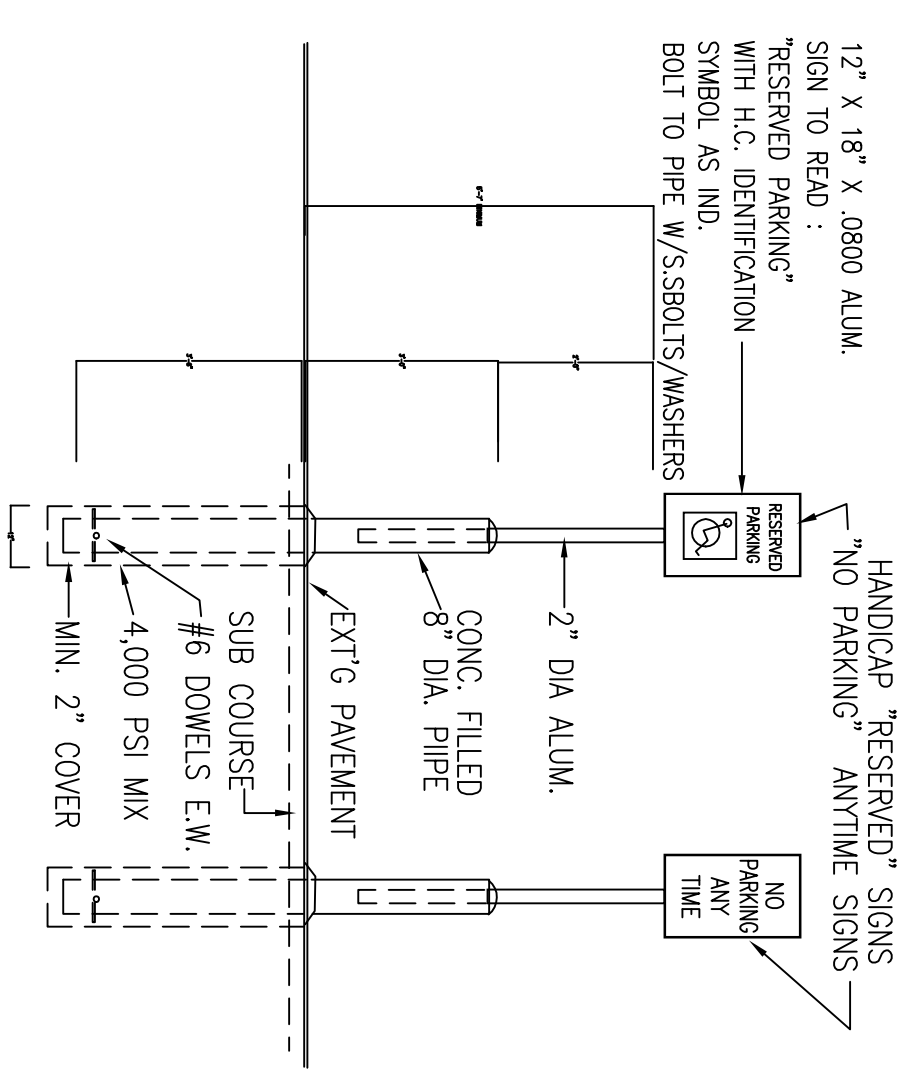

02 HANDICAP OR NO PARKING SIGNS

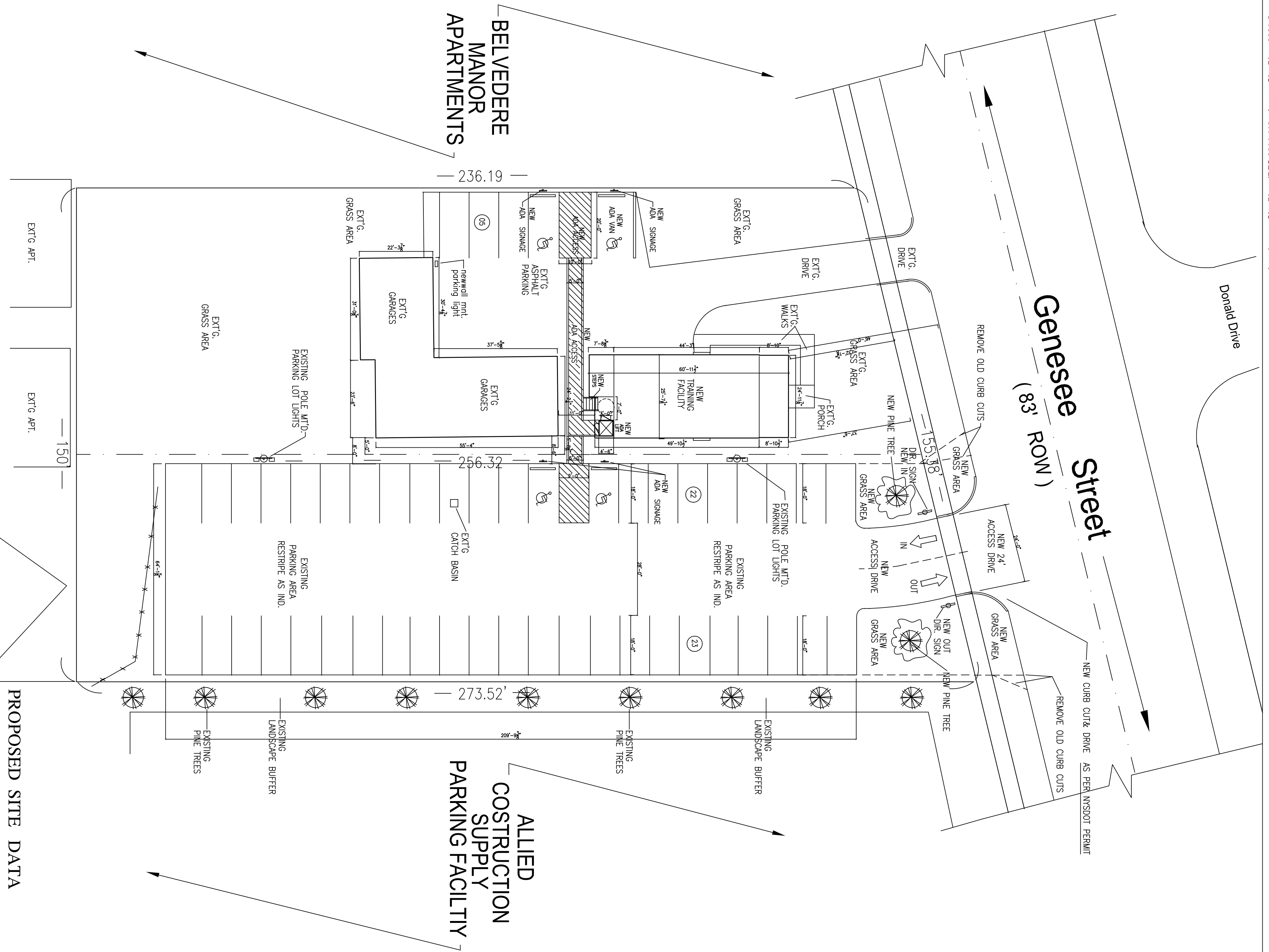

01 MASTER SITE PLAN

- 50 SPACES 9' X 18' - EXISTING
- 3 ADA COMP. SPACES
- 1 ADA COMP. VAN SPACE

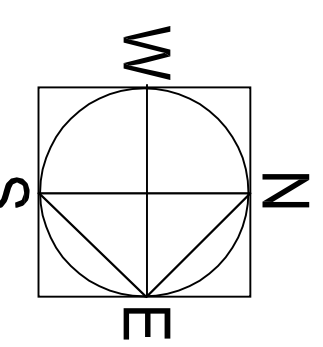

PROPOSED SITE DATA

DESCRIPTION	SF AREA	SF	ACRE	%
TOTAL SITE	38,786	0.89	AC	100
EXT'G. BUILDING	1,586	0.03	AC	4.10
EXT'G. GARAGES	2,100	0.05	AC	5.40
PARKING/WALKS	13,650	0.05	AC	35.20
REV. GREEN SPACE	21,450	1.03	AC	55.30

HEALTH FORCE
 MASTER SITE PLAN
 3881 GENESEE STREET
 TOWN OF CHEEKTOWAGA, NEW YORK

HEALTH FORCE
 MASTER SITE PLAN
 ADDITIONS & IMPROVEMENTS

PROJECT NO. 12-18-13
 SHEET NO. C1

NO.	DATE	REVISION	BY
1	02-11-14	ADDED TREES IN NEW GREEN AREAS PER REQUEST TOWN ENV. MTG.	RP

HEALTH FORCE
 Master Site Plan
 3881 GENESEE STREET
 TOWN OF CHEEKTOWAGA, NEW YORK

MS. PATRICIA M. KRALL-DWYER - PRESIDENT

WYLLIER & ASSOCIATES
 ARCHITECTS - ARCHITECTURE
 3072 Open Meadows Road
 716-844-6644 - MOBILE
 EMAIL: WYLLIER@WYLLIERCO.COM

WARNING:
 THIS IS A VIOLATION OF ARTICLE 147, SECTION 2 OF THE NEW YORK STATE GOVERNMENT EMPLOYERS' LIABILITY LAW, WHICH PROVIDES THAT ANY PARTY, ON THIS DOCUMENT, WHOSE NUMBER IS NOT IN THE LISTED ABOVE, IS NOT TO BE CONSIDERED AS A PARTY TO THIS DOCUMENT UNLESS INDICATED OTHERWISE BY THE DIRECTION OF A LICENSED ARCHITECT.



Town of Cheektowaga

Regular Meeting

~ Minutes ~

3301 Broadway
Cheektowaga, NY 14227
<http://www.town.cheektowaga.ny.us>

Alice Magierski
716-686-3400

Monday, March 3, 2014

6:45 PM

Council Chambers

I. Call to Order

6:45 PM Meeting called to order on March 3, 2014 at Council Chambers, 3301 Broadway St, Cheektowaga, NY.

Attendee Name	Organization	Title	Status	Arrived
Mary Holtz	Town of Cheektowaga	Supervisor	Present	
James P. Rogowski	Town of Cheektowaga	Councilmember	Present	
Charles Markel	Town of Cheektowaga	Councilmember	Present	
Gerald Kaminski	Town of Cheektowaga	Councilmember	Present	
Angela M. Wozniak	Town of Cheektowaga	Councilmember	Present	
Diane Benczkowski	Town of Cheektowaga	Councilmember	Present	
Timothy J. Meyers	Town of Cheektowaga	Councilmember	Absent	

2. Additional Attendees

Thomas Adamczak, Supervising Building and Plumbing Inspector
Brian Krause, Director of Finance and Administration
Stanley Kaznowski, Planning Board Chairman
William Pugh, Town Engineer
Kevin Schenk, Town Attorney

II. Public Comment Period

III. Resolutions



1. RESOLUTION 2014-138

Transfer of Funds-2013

Sponsored By: Supervisor Holtz, Councilmember Kaminski

BE IT RESOLVED, that the following transfer is hereby approved and made part hereof;
PART TOWN

FROM:	800.3620.2770	Permits & Inspections	\$2,680.00
TO:	800.3620.4411	Refunds of Permits	\$2,680.00
GENERAL			
FROM:	100.9010.8111	Police Retirement	\$189,789.00
	100.1440.1902	Overtime Payroll	4,724.00
TO:	100.1680.1901	Regular Payroll	\$5,188.00
	100.1680.1902	Overtime Payroll	35,477.00
	100.1680.1914	Shift Differential	190.00
	100.1680.2202	Network Hardware	63,052.00
	100.1680.2204	Computer Hardware	84,225.00
	100.1680.4001	Office Supplies	8.00
	100.1680.4088	Travel, Training & Conferences	249.00
	100.1680.4206	Internet Services	139.00
	100.1680.4431	Hardware Maintenance	107.00
	100.1680.4434	Software Maintenance	387.00
	100.1680.4437	Pooled Maintenance Costs	567.00
	100.3120.4433	Genesee Storefront	200.00
	100.1440.2501	Engineering Misc. Office Equipment	4,724.00

RESULT:	ADOPTED [UNANIMOUS]
MOVER:	Mary Holtz, Supervisor
SECONDER:	Gerald Kaminski, Councilmember
AYES:	Holtz, Rogowski, Markel, Kaminski, Wozniak, Benczkowski
ABSENT:	Timothy J. Meyers



2. RESOLUTION 2014-139

Warrant

Sponsored By: Supervisor Holtz, Councilmember Kaminski

BE IT RESOLVED, that the following Vouchers & Warrants submitted to the Town of Cheektowaga prior to March 3, 2013 are hereby approved and made part hereof;

GENERAL FUND	\$330,616.64
RISK RETENTION FUND	100,489.29
NYS HOME PROGRAM	
DEBT	
HUD HOUSING REHABILITATION FUND	
SPECIAL DISTRICTS FUND	241,974.22
HIGHWAY FUND	56,467.37
CAPITAL FUND	6,767.85
TRUST & AGENCY FUND	4,052.39
HUD CDBG FUND	28,941.14
PART TOWN FUND	4,272.84
NYS AFFORDABLE HOUSING	
	\$773,581.74

RESULT:	ADOPTED [UNANIMOUS]
MOVER:	Mary Holtz, Supervisor
SECONDER:	Gerald Kaminski, Councilmember
AYES:	Holtz, Rogowski, Markel, Kaminski, Wozniak, Benczkowski
ABSENT:	Timothy J. Meyers



3. RESOLUTION 2014-140

Award of Bid - Work Uniforms (Bid #2014-7)

Sponsored By: Supervisor Holtz, Councilmember Kaminski

WHEREAS, a Notice to Bidders was duly published for the receipt of bids for the furnishing of Work Uniforms for calendar year 2014, which bids were duly received and opened by the Office of the Town Clerk at a public bid opening on February 19, 2014, AND

WHEREAS, said bids were referred to the Town Engineer for analysis, tabulation and report, AND

WHEREAS, said report recommends that the bid for the furnishing of Work Uniforms be awarded to The Liberty Store for their bid proposal, being the lowest bid meeting the requirements of the specifications, NOW, THEREFORE, BE IT

RESOLVED, that the bid for the furnishing of Work Uniforms for calendar year 2014 is hereby awarded to:

The Liberty Store
5 East Genesee Street
Auburn, New York 13021

for the unit prices for individual bid items as stated below:

BID ITEM I

Item 1A	Work Pants (sizes to 44)	\$18.00
Item 1B	Work Pants (sizes 46-50)	\$19.74
Item 1C	Work Pants (sizes 52-60)	\$19.74
Item 2A	Shirts (long sleeve, sizes up to 17-1/2)	\$15.87
Item 2B	Shirts (long sleeve, sizes 18 and up)	\$17.37
Item 3A	Chambray Shirts (long sleeve, sizes up to 17-1/2)	\$14.88
Item 3B	Chambray Shirts (long sleeve, sizes 18 and up)	\$16.12
Item 4A	Shirts (short sleeve, sizes up to 17-1/2)	\$14.88
Item 4B	Shirts (short sleeve, sizes 18 and up)	\$16.12
Item 5A	Chambray Shirts (short sleeve, sizes up to 17-1/2)	\$13.12
Item 5B	Chambray Shirts (short sleeve, sizes 18 and up)	\$14.37

Item 6A	Coveralls (long sleeve, sizes 36-46, short - X-long)	\$28.63
Item 6B	Coveralls (long sleeve, sizes 48-50, short - X-long)	\$28.63
Item 6C	Coveralls (long sleeve, sizes 52-60, short - X-long)	\$32.54
Item 7A	Denim Jeans (sizes 28-42)	\$13.30
Item 7B	Denim Jeans (sizes 44-50)	\$14.88
Item 7C	Denim Jeans (sizes 52-56)	\$16.05
Item 8A	Bib Overalls (sizes to 44)	\$23.05
Item 8B	Bib Overalls (sizes 46-50)	\$24.87
Item 8C	Bib Overalls (sizes 52-60)	\$27.12
Item 9A	Women's Work Pants (sizes 4-20)	\$14.37
Item 9B	Women's Work Pants (sizes 22-28)	\$16.19

BID ITEM II

Item 1A	High Visibility Jacket (sizes S-XL)	\$48.85
Item 1B	High Visibility Jacket (size 2XL)	\$48.85
Item 1C	High Visibility Jacket (size 3XL)	\$48.85
Item 1D	High Visibility Jacket (size 4XL)	\$48.85
Item 1E	High Visibility Jacket (size 5XL)	\$48.85
Item 1F	High Visibility Jacket (size 6XL)	\$48.85

BID ITEM III

Item 1A	Hooded Pullover Sweatshirt (sizes S-XL)	\$16.08
Item 1B	Hooded Pullover Sweatshirt (size 2XL)	\$21.26
Item 1C	Hooded Pullover Sweatshirt (size 3XL)	\$21.26
Item 1D	Hooded Pullover Sweatshirt (size 4XL)	\$21.26
Item 2A	Hooded Zipper Sweatshirt (sizes S-XL)	\$23.56
Item 2B	Hooded Zipper Sweatshirt (size 2XL)	\$26.53

Item 2C	Hooded Zipper Sweatshirt (size 3XL)	\$26.53
Item 2D	Hooded Zipper Sweatshirt (size 4XL)	\$26.53
Item 3A	Heavy Duty Sweatshirt (sizes S-XL)	\$ 9.75
Item 3B	Heavy Duty Sweatshirt (size 2XL)	\$13.15
Item 3C	Heavy Duty Sweatshirt (size 3XL)	\$13.15
Item 3D	Heavy Duty Sweatshirt (size 4XL)	\$13.15

BID ITEM IV

Item 1A	Carhartt Bib Overall (sizes 34-48)	\$79.93
Item 2A	Carhartt Bib Overall (size 50)	\$79.93

BID ITEM V

Item 1A	Tee Shirt (sizes M-XL)	\$ 3.80
Item 1B	Tee Shirt (size 2XL)	\$ 5.85
Item 1C	Tee Shirt (size 3XL)	\$ 5.85
Item 1D	Tee Shirt (size 4/5XL)	\$ 5.85
Item 2A	Pocket Tee Shirt (size M-XL)	\$ 5.32
Item 2B	Pocket Tee Shirt (size 2XL)	\$ 6.41
Item 2C	Pocket Tee Shirt (size 3XL)	\$ 6.41
Item 2D	Pocket Tee Shirt (size 4/5XL)	\$ 6.41
Item 3A	Long Sleeve Tee Shirt (size M-XL)	\$ 6.84
Item 3B	Long Sleeve Tee Shirt (size 2XL)	\$ 9.24
Item 3C	Long Sleeve Tee Shirt (size 3XL)	\$ 9.24
Item 3D	Long Sleeve Tee Shirt (size 4/5XL)	\$ 9.24
Item 4A	Long Sleeve Tee Shirt W/Pocket (size M-XL)	\$ 8.11
Item 4B	Long Sleeve Tee Shirt W/Pocket (size 2XL)	\$10.03

Item 4C	Long Sleeve Tee Shirt W/Pocket (size 3XL)	\$10.03
Item 4D	Long Sleeve Tee Shirt W/Pocket (size 4/5XL)	\$10.03

RESULT: ADOPTED [UNANIMOUS]
MOVER: Mary Holtz, Supervisor
SECONDER: Gerald Kaminski, Councilmember
AYES: Holtz, Rogowski, Markel, Kaminski, Wozniak, Benczkowski
ABSENT: Timothy J. Meyers



4. RESOLUTION 2014-141

Award of Bid - Street Light Standards (Bid #2014-9)

Sponsored By: Councilmember Markel, Supervisor Holtz

WHEREAS, a Notice to Bidders was duly published for the receipt of bids for the purchase of round tapered aluminum street light standards with elliptical arms, which bids were duly opened on February 19, 2014, AND

WHEREAS, said bids were referred to the Town Engineer for analysis, tabulation and report, AND

WHEREAS, said report recommends that the bid for the furnishing of round tapered aluminum street light standards with elliptical arms be awarded to Shanor Electric Supply, Inc. for their bid proposal, being the lowest bid meeting the requirements of the specifications, NOW, THEREFORE, BE IT

RESOLVED, that the bid for the furnishing of round tapered aluminum street light standards with elliptical arms is hereby awarded to:

Shanor Electric Supply, Inc.
285 Hinman Avenue
Buffalo, New York 14216

for their unit price bid of \$775.10 each and total bid for a quantity of twenty-five (25) in the amount of \$19,377.50 to be chargeable to the Town's General Lighting District Budget.

RESULT:	ADOPTED [UNANIMOUS]
MOVER:	Charles Markel, Councilmember
SECONDER:	Mary Holtz, Supervisor
AYES:	Holtz, Rogowski, Markel, Kaminski, Wozniak, Benczkowski
ABSENT:	Timothy J. Meyers



5. RESOLUTION 2014-142

Accept Site Plan-1601 Walden Avenue

Sponsored By: Councilmember Markel, Councilmember Rogowski

WHEREAS, pursuant to the Zoning Law of the Town of Cheektowaga, the Planning Board reviews various development review applications for site plans, rezonings, special permits and realty subdivisions and renders its recommendation concerning the compatibility of such application with the zoning regulations, the Town Master Plan and neighborhood character, AND

WHEREAS, the Town Board, pursuant to section 260-47.1C of the Zoning Law of the Town of Cheektowaga is vested with the authority to approve site plans and modify or reject any recommendation submitted to it by its advisory committees, AND

WHEREAS, Autozone, Inc. Submitted a development review application for the a parking area expansion at 1601 Walden Avenue, AND

WHEREAS, the Town of Cheektowaga Planning Board, reviewed and commented on the Application at their meeting of January 9, 2014 and have recommended approval thereof, NOW THEREFORE BE IT,

RESOLVED, that pursuant to Section 260-47-1 of the Code of the Town of Cheektowaga and Section 274-a of New York State Town Law that this Town Board approves the proposed site plan subject to:

1. The Town Engineer reviewing/approving the grading and drainage plan.

Attachments:

finalAUTOZONE C-1 SITE PLAN (PDF)
landscape plan (PDF)

RESULT:	ADOPTED [UNANIMOUS]
MOVER:	Charles Markel, Councilmember
SECONDER:	James P. Rogowski, Councilmember
AYES:	Holtz, Rogowski, Markel, Kaminski, Wozniak, Benczkowski
ABSENT:	Timothy J. Meyers



6. RESOLUTION 2014-143

**Call for Public Hearing for District Improvements -
Replacement of Sanitary Sewers**

Sponsored By: Supervisor Holtz, Councilmember Kaminski

At a regular meeting of the Town Board of the Town of Cheektowaga, in the County of Erie, New York, held at the Town Hall, 3301 Broadway, Cheektowaga, New York, on the 3rd day of March, 2014.

PRESENT:

- Hon. Mary F. Holtz, Supervisor
- James P. Rogowski, Councilmember
- Charles C. Markel, Councilmember
- Gerald P. Kaminski, Councilmember
- Angela M. Wozniak, Councilmember
- Diane M. Benzckowski, Councilmember

Absent: Timothy J. Meyers, Councilmember

In the Matter

of the

Increase and Improvement of Facilities of the Consolidated Sewer District, in the Town of Cheektowaga, in the County of Erie, New York, pursuant to Section 202-b of the Town Law

Offered by: Mary F. Holtz, Supervisor

Seconded by: Gerald P. Kaminski Sr., Councilmember

ORDER CALLING FOR A PUBLIC HEARING TO BE HELD ON MARCH 17, 2014

WHEREAS, the Town Board of the Town of Cheektowaga (herein called the

“Town”), in the County of Erie, New York, on behalf of the Consolidated Sewer District, in the Town (herein referred to as the “District”), has proposed an increase and improvement of facilities of the District, consisting of the replacement of various sanitary sewers at the estimated maximum cost of \$700,000; and

WHEREAS, the Town Board, as lead agency, has given due consideration to the impact that such increase and improvement of facilities may have on the environment and has determined that the proposed project is a Type II action pursuant to the State Environmental Quality Review Act (SEQRA), constituting Article 8 of the Environmental Conservation Law, and 6 N.Y.C.R.R., Regulations Part 617 and no further environmental review is required pursuant to SEQRA;

NOW, THEREFORE, BE IT

ORDERED, that a meeting of the Town Board of the Town be held at the Town Hall, 3301 Broadway, Cheektowaga, New York, on the 17th day of March, 2014 at 6:45 o'clock P.M. (Prevailing Time) to consider said proposed increase and improvement of facilities of the District and to hear all persons interested in the subject thereof concerning the same and for such other action on the part of the Town Board with relation thereto as may be required by law; and be it,

FURTHER ORDERED, that the Town Clerk publish at least once in the “*Cheektowaga Bee*,” hereby designated as the official newspaper of the Town for such publication, and post on the sign board of the Town maintained pursuant to subdivision 6 of Section 30 of the Town Law, a Notice of such public hearing, substantially in the form attached hereto as Exhibit A, the first publication thereof and said posting to be not less than ten (10) nor more than twenty (20) days before the date of such public hearing.

DATED: March 3, 2014

TOWN BOARD OF THE TOWN OF
CHEEKTOWAGA

(SEAL)

The adoption of the foregoing Order was seconded by Gerald P. Kaminski and duly put to a vote on roll call, which resulted as follows:

Supervisor Mary F. Holtz	voting_AYE
Councilmember James P. Rogowski	voting_AYE
Councilmember Charles C. Markel	voting_AYE
Councilmember Gerald P. Kaminski	voting_AYE
Councilmember Angela M. Wozniak	voting_AYE
Councilmember Diane M. Benczkowski	voting_AYE
Councilmember Timothy J. Meyers	voting_Absent

The Order was declared adopted.

* * * * *

CERTIFICATE

I, ALICE MAGIERSKI, Town Clerk of the Town of Cheektowaga, in the County of Erie, State of New York, DO HEREBY CERTIFY that I have compared the preceding Order Calling for a Public Hearing with the original thereof filed in the office of the Town Clerk on the 3rd day of March, 2014, and that the same is a true and correct copy of said original and of the whole thereof.

IN WITNESS WHEREOF, I have hereunto set my hand and affixed the corporate seal of said Town on this 3rd day of March, 2014.

(SEAL)

Alice Magierski, Town Clerk
Town of Cheektowaga

Exhibit A

NOTICE OF PUBLIC HEARING

NOTICE IS HEREBY GIVEN that the Town Board of the Town of Cheektowaga, in the County of Erie, State of New York, will meet at the Town Hall, 3301 Broadway, Cheektowaga, New York, on March 17, 2014, at 6:45 o'clock P.M. (Prevailing Time), for the purpose of conducting a public hearing in relation to the proposed increase and improvement of facilities of the Consolidated Sewer District, consisting of the replacement of various sanitary sewers, at the estimated maximum cost of \$700,000.

At said public hearing, the Town Board will hear all persons interested in said subject matter thereof.

Dated: March 3, 2014
Cheektowaga, New York

BY ORDER OF THE TOWN BOARD OF THE
TOWN OF CHEEKTOWAGA, COUNTY OF ERIE,
STATE OF NEW YORK

By _____

Alice Magierski, Town Clerk

Town of Cheektowaga

RESULT:	ADOPTED [UNANIMOUS]
MOVER:	Mary Holtz, Supervisor
SECONDER:	Gerald Kaminski, Councilmember
AYES:	Holtz, Rogowski, Markel, Kaminski, Wozniak, Benczkowski
ABSENT:	Timothy J. Meyers



7. RESOLUTION 2014-144

Bond Resolution for Acquisition of Recycling Totes

Sponsored By: Supervisor Holtz, Councilmember Kaminski

EXTRACT OF MINUTES

Meeting of the Town Board of the

Town of Cheektowaga, in the

County of Erie, New York

March 3, 2014

* * *

A regular meeting of the Town Board of the Town of Cheektowaga, in the County of Erie, New York, was held at the Town Hall, 3301 Broadway, Cheektowaga, New York, on March 3, 2014.

There were present: Hon. Mary F. Holtz, Supervisor; and

Board Members: James P. Rogowski
Charles C. Markel
Gerald P. Kaminski Sr.
Angela M. Wozniak
Diane M. Benczkowski

There were absent: Timothy J. Meyers

Also present: Alice Magierski, Town Clerk

* * *

Hon. Mary F. Holtz offered the following resolution and moved its adoption:

BOND RESOLUTION OF THE TOWN OF CHEEKTOWAGA,

NEW YORK, ADOPTED MARCH 3, 2014, AUTHORIZING THE ACQUISITION OF RECYCLING TOTES, STATING THE ESTIMATED MAXIMUM COST THEREOF IS \$1,000,000, APPROPRIATING SAID AMOUNT FOR SUCH PURPOSE, AND AUTHORIZING THE ISSUANCE OF BONDS IN THE PRINCIPAL AMOUNT OF \$1,000,000 TO FINANCE SAID APPROPRIATION

THE TOWN BOARD OF THE TOWN OF CHEEKTOWAGA, IN THE COUNTY OF ERIE, NEW YORK, HEREBY RESOLVES (by the favorable vote of not less than two-thirds of all the members of said Town Board) AS FOLLOWS:

Section 1. The Town of Cheektowaga, in the County of Erie, New York (herein called the "Town"), is hereby authorized to acquire recycling totes. The estimated maximum cost thereof, including preliminary costs and costs incidental thereto and the financing thereof, is \$1,000,000 and said amount is hereby appropriated for such purpose. The plan of financing includes the issuance of \$1,000,000 serial bonds of the Town to finance said appropriation, and the levy and collection of taxes on all the taxable real property in the Town to pay the principal of said bonds and the interest thereon as the same shall become due and payable.

Section 2. Serial bonds of the Town in the principal amount of \$1,000,000 are hereby authorized to be issued pursuant to the provisions of the Local Finance Law, constituting Chapter 33-a of the Consolidated Laws of the State of New York (herein called the "Law"), to finance a part of said appropriation.

Section 3. The following additional matters are hereby determined and declared:

(a) The period of probable usefulness applicable to the object or purpose for

which said bonds are authorized to be issued, within the limitations of Section 11.00 a. 35 of the Law, is five (5) years.

(b) The proceeds of the bonds herein authorized and any bond anticipation notes issued in anticipation of said bonds may be applied to reimburse the Town for expenditures made after the effective date of this resolution for the purpose for which said bonds are authorized. The foregoing statement of intent with respect to reimbursement is made in conformity with Treasury Regulation Section 1.150-2 of the United States Treasury Department.

(c) The proposed maturity of the bonds authorized by this resolution will not exceed five (5) years.

Section 4. Each of the bonds authorized by this resolution and any bond anticipation notes issued in anticipation of the sale of said bonds shall contain the recital of validity as prescribed by Section 52.00 of the Law and said bonds and any notes issued in anticipation of said bonds shall be general obligations of the Town, payable as to both principal and interest by general tax upon all the taxable real property within the Town. The faith and credit of the Town are hereby irrevocably pledged to the punctual payment of the principal of and interest on said bonds and any notes issued in anticipation of the sale of said bonds and provision shall be made annually in the budget of the Town by appropriation for (a) the amortization and redemption of the bonds and any notes in anticipation thereof to mature in such year and (b) the payment of interest to be due and payable in such year.

Section 5. Subject to the provisions of this resolution and of the Law and pursuant to the provisions of Section 21.00 relative to the authorization of bonds with substantially level or declining annual debt service, Section 30.00 relative to the authorization of the issuance of bond anticipation notes and Section 50.00 and Sections 56.00 to 60.00 and Section 168.00 of the Law, the powers and duties of the Town Board relative to authorizing bond

anticipation notes and prescribing the terms, form and contents and as to the sale and issuance of the bonds herein authorized, and of any bond anticipation notes issued in anticipation of said bonds, and the renewals of said bond anticipation notes, and as to the execution of agreements for credit enhancements, are hereby delegated to the Supervisor, the chief fiscal officer of the Town.

Section 6. The validity of the bonds authorized by this resolution, and of any notes issued in anticipation of the sale of said bonds, may be contested only if:

- (a) such obligations are authorized for an object or purpose for which the Town is not authorized to expend money, or
- (b) the provisions of law which should be complied with at the date of the publication of such resolution, or a summary thereof, are not substantially complied with,

and an action, suit or proceeding contesting such validity is commenced within twenty days after the date of such publication, or

- (c) such obligations are authorized in violation of the provisions of the constitution.

Section 7. This bond resolution shall take effect immediately, and the Town Clerk is hereby authorized and directed to publish the foregoing resolution, in summary, together with a Notice attached in substantially the form prescribed by Section 81.00 of the Law in the "*Cheektowaga Bee*," a newspaper having a general circulation within said Town and hereby designated as the official newspaper of the Town for such publication.

* * *

The adoption of the foregoing resolution was seconded by Gerald P. Kaminski

and duly put to a vote on roll call, which resulted as follows:

AYES: Supervisor Holtz; Councilmember James P. Rogowski; Councilmember Charles Markel; Councilmember Gerald P. Kaminski Sr.; Councilmember Angela Wozniak; Councilmember Diane Benczkowski

ABSENT: Councilmember Timothy J. Meyers

The resolution was declared adopted.

CERTIFICATE

I, ALICE MAGIERSKI, Town Clerk of the Town of Cheektowaga, in the County of Erie, State of New York, HEREBY CERTIFY that the foregoing annexed extract from the minutes of a meeting of the Town Board of said Town of Cheektowaga duly called and held on March 3, 2014, has been compared by me with the original minutes as officially recorded in my office in the Minute Book of said Town Board and is a true, complete and correct copy thereof and of the whole of said original minutes so far as the same relate to the subject matters referred to in said extract.

IN WITNESS WHEREOF, I have hereunto set my hand and affixed the corporate seal of said Town of Cheektowaga this 3rd day of March, 2014.

(SEAL)

Alice Magierski Town Clerk

NOTICE

The resolution, a summary of which is published herewith, has been adopted on March 3, 2014 and the validity of the obligations authorized by such resolution may be hereafter contested only if such obligations were authorized for an object or purpose for which the Town of Cheektowaga, in the County of Erie, New York, is not authorized to expend money or if the provisions of law which should have been complied with as of the date of publication of this Notice were not substantially complied with, and an action, suit or proceeding contesting such validity is commenced within twenty days after the publication of this Notice, or such obligations were authorized in violation of the provisions of the constitution.

ALICE MAGIERSKI
Town Clerk

BOND RESOLUTION OF THE TOWN OF CHEEKTOWAGA,
NEW YORK, ADOPTED MARCH 3, 2014, AUTHORIZING
THE ACQUISITION OF RECYCLING TOTES, STATING THE
ESTIMATED MAXIMUM COST THEREOF IS \$1,000,000,
APPROPRIATING SAID AMOUNT FOR SUCH PURPOSE,
AND AUTHORIZING THE ISSUANCE OF BONDS IN THE
PRINCIPAL AMOUNT OF \$1,000,000 TO FINANCE SAID
APPROPRIATION

The object or purpose for which the bonds are authorized is the acquisition of recycling totes, at the estimated maximum cost of \$1,000,000.

The amount of obligations authorized to be issued is \$1,000,000.

The period of probable usefulness is five (5) years.

A complete copy of the bond resolution summarized above shall be available for public inspection during normal business hours at the office of the Town Clerk, Town of Cheektowaga, 3301 Broadway, Cheektowaga, New York.

RESULT:	ADOPTED [UNANIMOUS]
MOVER:	Mary Holtz, Supervisor
SECONDER:	Gerald Kaminski, Councilmember
AYES:	Holtz, Rogowski, Markel, Kaminski, Wozniak, Benczkowski
ABSENT:	Timothy J. Meyers



8. RESOLUTION 2014-145

**Bond Resolution Authorizing Drainage Improvements on
Town Highways**

Sponsored By: Supervisor Holtz, Councilmember Kaminski

EXTRACT OF MINUTES

Meeting of the Town Board of the

Town of Cheektowaga,

in the County of Erie, New York

March 3, 2014

A regular meeting of the Town Board of the Town of Cheektowaga, in the County of Erie, New York, was held at the Town Hall, 3301 Broadway, Cheektowaga, New York, on March 3, 2014.

There were present: Hon. Mary F. Holtz, Supervisor; and

Board Members: James P. Rogowski
Charles C. Markel
Gerald P. Kaminski
Angela M. Wozniak
Diane M. Benczkowski

There were absent: Timothy J. Meyers

Also present: Alice Magierski, Town Clerk

* * *

Hon. Mary F. Holtz, offered the following resolution and moved

its adoption:

BOND RESOLUTION OF THE TOWN OF CHEEKTOWAGA, NEW YORK, ADOPTED MARCH 3, 2014, AUTHORIZING THE CONSTRUCTION OF DRAINAGE IMPROVEMENTS ON TOWN HIGHWAYS, STATING THE ESTIMATED MAXIMUM COST THEREOF IS \$1,150,000, APPROPRIATING SAID AMOUNT FOR SUCH PURPOSE, AND AUTHORIZING THE ISSUANCE OF \$1,150,000 SERIAL BONDS OF SAID TOWN TO FINANCE SAID APPROPRIATION

THE TOWN BOARD OF THE TOWN OF CHEEKTOWAGA, IN THE COUNTY OF ERIE, NEW YORK, HEREBY RESOLVES (by the favorable vote of not less than two-thirds of all the members of said Town Board) AS FOLLOWS:

Section 1. The Town of Cheektowaga, in the County of Erie, New York (herein called the "Town"), is hereby authorized to construct drainage improvements on Town highways. The estimated maximum cost thereof, including preliminary costs and costs incidental thereto and the financing thereof, is \$1,150,000 and said amount is hereby appropriated for such purpose. The plan of financing includes the issuance of \$1,150,000 serial bonds of the Town to finance said appropriation, and the levy and collection of taxes on all the taxable real property in the Town to pay the principal of said bonds and the interest thereon as the same shall become due and payable.

Section 2. Serial bonds of the Town in the principal amount of \$1,150,000 are hereby authorized to be issued pursuant to the provisions of the Local Finance Law, constituting Chapter 33-a of the Consolidated Laws of the State of New York (herein called the "Law"), to finance said appropriation.

Section 3. The following additional matters are hereby determined and declared:

(a) The period of probable usefulness applicable to the object or purpose for which said bonds are authorized to be issued, within the limitations of Section 11.00 a. 4 of the Law, is forty (40) years.

(b) The proceeds of the bonds herein authorized and any bond anticipation notes issued in anticipation of said bonds may be applied to reimburse the Town for expenditures made after the effective date of this resolution for the purpose for which said bonds are authorized. The foregoing statement of intent with respect to reimbursement is made in conformity with Treasury Regulation Section 1.150-2 of the United States Treasury Department.

(c) The proposed maturity of the bonds authorized by this resolution will exceed five (5) years.

Section 4. Each of the bonds authorized by this resolution and any bond anticipation notes issued in anticipation of the sale of said bonds shall contain the recital of validity as prescribed by Section 52.00 of the Law and said bonds and any notes issued in anticipation of said bonds shall be general obligations of the Town, payable as to both principal and interest by general tax upon all the taxable real property within the Town. The faith and credit of the Town are hereby irrevocably pledged to the punctual payment of the principal of and interest on said bonds and any notes issued in anticipation of the sale of said bonds and provision shall be made annually in the budget of the Town by appropriation for (a) the amortization and redemption of the bonds and any notes in anticipation thereof to mature in such year and (b) the payment of interest to be due and payable in such year.

Section 5. Subject to the provisions of this resolution and of the Law and pursuant to the provisions of Section 21.00 relative to the authorization of bonds with substantially level or declining annual debt service, Section 30.00 relative to the authorization of

the issuance of bond anticipation notes and Section 50.00 and Sections 56.00 to 60.00 and Section 168.00 of the Law, the powers and duties of the Town Board relative to authorizing bond anticipation notes and prescribing the terms, form and contents and as to the sale and issuance of the bonds herein authorized, and of any bond anticipation notes issued in anticipation of said bonds, and the renewals of said bond anticipation notes, and as to the execution of agreements for credit enhancements, are hereby delegated to the Supervisor, the chief fiscal officer of the Town.

Section 6. The validity of the bonds authorized by this resolution, and of any notes issued in anticipation of the sale of said bonds, may be contested only if:

- (a) such obligations are authorized for an object or purpose for which the Town is not authorized to expend money, or
- (b) the provisions of law which should be complied with at the date of the publication of such resolution, or a summary thereof, are not substantially complied with,

and an action, suit or proceeding contesting such validity is commenced within twenty days after the date of such publication, or

- (c) such obligations are authorized in violation of the provisions of the constitution.

Section 7. This bond resolution is subject to a permissive referendum and the Town Clerk is hereby authorized and directed, within ten (10) days after the adoption of this resolution, to cause to be published, in full, in the "*Cheektowaga Bee*," a newspaper having a general circulation within said Town and hereby designated the official newspaper of the Town for such publication and posted on the sign board of the Town maintained pursuant to the Town Law, a Notice in substantially the following form:

TOWN OF CHEEKTOWAGA, NEW YORK

PLEASE TAKE NOTICE that on March 3, 2014, the Town Board of the Town of Cheektowaga, in the County of Erie, New York, adopted a bond resolution entitled:

“Bond Resolution of the Town of Cheektowaga, New York, adopted March 3, 2014, authorizing the construction of drainage improvements on Town highways, stating the estimated maximum cost thereof is \$1,150,000, appropriating said amount for such purpose, and authorizing the issuance of \$1,150,000 serial bonds of said Town to finance said appropriation,”

an abstract of which bond resolution concisely stating the purpose and effect thereof, being as follows:

FIRST: AUTHORIZING said Town to construct drainage improvements on Town highways; STATING the estimated maximum cost thereof, including preliminary costs, and costs incidental thereto and the financing thereof, is \$1,150,000; APPROPRIATING said amount for such purpose; and STATING the plan of financing includes the issuance of \$1,150,000 serial bonds of the Town to finance said appropriation, and the levy of a tax upon all the taxable real property within the Town to pay the principal of said bonds and interest thereon;

SECOND: AUTHORIZING the issuance of \$1,150,000 serial bonds of the Town pursuant to the Local Finance Law of the State of New York (the “Law”) to finance said appropriation;

THIRD: DETERMINING and STATING the period of probable usefulness applicable to the purpose for which said serial bonds are authorized to be issued is forty (40) years; the proceeds of said bonds and any bond anticipation notes issued in anticipation thereof may be applied to reimburse the Town for expenditures made after the effective date of this bond resolution for the purpose for which said bonds are authorized; and the proposed maturity of said \$1,150,000 serial bonds will exceed five (5) years;

FOURTH: DETERMINING that said bonds and any bond anticipation notes issued in anticipation of said bonds and the renewals of said bond anticipation notes shall be general obligations of the Town; and PLEDGING to their payment the faith and credit of the Town;

FIFTH: DELEGATING to the Supervisor the powers and duties as to the issuance of said bonds and any bond anticipation notes issued in anticipation of said bonds, or the renewals thereof; and

SIXTH: DETERMINING that the bond resolution is subject to a permissive referendum.

DATED: March 3, 2014

Alice Magierski
Town Clerk

Section 8. The Town Clerk is hereby authorized and directed to cause said bond resolution to be published, in summary, after said bond resolution shall take effect, in the newspaper referred to in Section 7 hereof, and hereby designated the official newspaper for said publication, together with a Notice in substantially the form as provided by Section 81.00 of the Local Finance Law, constituting Chapter 33-a of the Consolidated Laws of the State of New York.

* * *

The adoption of the foregoing resolution was seconded by Gerald P. Kaminski and
duly put to a vote on roll call, which resulted as follows:

AYES: Supervisor Holtz; Councilmember James P. Rogowski; Councilmember
Charles Markel; Councilmember Gerald P. Kaminski Sr.; Councilmember Angela
Wozniak; Councilmember Diane Benczkowski

ABSENT: Councilmember Timothy J. Meyers

The resolution was declared adopted.

CERTIFICATE

I, ALICE MAGIERSKI, Town Clerk of the Town of Cheektowaga, in the County of Erie, State of New York, HEREBY CERTIFY that the foregoing annexed extract from the minutes of a meeting of the Town Board of said Town of Cheektowaga duly called and held on March 3, 2014, has been compared by me with the original minutes as officially recorded in my office in the Minute Book of said Town Board and is a true, complete and correct copy thereof and of the whole of said original minutes so far as the same relate to the subject matters referred to in said extract.

IN WITNESS WHEREOF, I have hereunto set my hand and affixed the corporate seal of said Town of Cheektowaga this 3rd day of March, 2014.

(SEAL)

Town Clerk

RESULT:	ADOPTED [UNANIMOUS]
MOVER:	Mary Holtz, Supervisor
SECONDER:	Gerald Kaminski, Councilmember
AYES:	Holtz, Rogowski, Markel, Kaminski, Wozniak, Benczkowski
ABSENT:	Timothy J. Meyers



9. RESOLUTION 2014-146

Bond Resolution for Reconstruction of Various Sidewalks

Sponsored By: Supervisor Holtz, Councilmember Kaminski

EXTRACT OF MINUTES

Meeting of the Town Board of the

Town of Cheektowaga,

in the County of Erie, New York

March 3, 2014

A regular meeting of the Town Board of the Town of Cheektowaga, in the County of Erie, New York, was held at the Town Hall, 3301 Broadway, Cheektowaga, New York, on March 3, 2014.

There were present: Hon. Mary F. Holtz, Supervisor; and

Board Members: James P. Rogowski
Charles C. Markel
Gerald P. Kaminski Sr.
Angela M. Wozniak
Diane M. Benczkowski

There were absent: Timothy J. Meyers

Also present: Alice Magierski, Town Clerk

* * *

Hon. Mary F. Holtz offered the following resolution and moved its adoption:

BOND RESOLUTION OF THE TOWN OF CHEEKTOWAGA, NEW YORK, ADOPTED MARCH 3, 2014, AUTHORIZING THE RECONSTRUCTION OF VARIOUS SIDEWALKS IN THE TOWN, STATING THE ESTIMATED MAXIMUM COST THEREOF IS \$350,000, APPROPRIATING SAID AMOUNT FOR SUCH PURPOSE, AND AUTHORIZING THE ISSUANCE OF \$350,000 SERIAL BONDS OF SAID TOWN TO FINANCE SAID APPROPRIATION

THE TOWN BOARD OF THE TOWN OF CHEEKTOWAGA, IN THE COUNTY OF ERIE, NEW YORK, HEREBY RESOLVES (by the favorable vote of not less than two-thirds of all the members of said Town Board) AS FOLLOWS:

Section 1. The Town of Cheektowaga, in the County of Erie, New York (herein called the "Town"), is hereby authorized to reconstruct various sidewalks in the Town. The estimated maximum cost thereof, including preliminary costs and costs incidental thereto and the financing thereof, is \$350,000 and said amount is hereby appropriated for such purpose. The plan of financing includes the issuance of \$350,000 serial bonds of the Town to finance said appropriation, and the levy and collection of taxes on all the taxable real property in the Town to pay the principal of said bonds and the interest thereon as the same shall become due and payable.

Section 2. Serial bonds of the Town in the principal amount of \$350,000 are hereby authorized to be issued pursuant to the provisions of the Local Finance Law, constituting Chapter 33-a of the Consolidated Laws of the State of New York (herein called the "Law"), to finance said appropriation.

Section 3. The following additional matters are hereby determined and declared:

(a) The period of probable usefulness applicable to the object or purpose for which said bonds are authorized to be issued, within the limitations of Section 11.00 a. 24 of the Law, is ten (10) years.

(B) The proceeds of the bonds herein authorized and any bond anticipation notes issued in anticipation of said bonds may be applied to reimburse the Town for expenditures made after the effective date of this resolution for the purpose for which said bonds are authorized. The foregoing statement of intent with respect to reimbursement is made in conformity with Treasury Regulation Section 1.150-2 of the United States Treasury Department.

(C) The proposed maturity of the bonds authorized by this resolution will exceed five (5) years.

Section 4. Each of the bonds authorized by this resolution and any bond anticipation notes issued in anticipation of the sale of said bonds shall contain the recital of validity as prescribed by Section 52.00 of the Law and said bonds and any notes issued in anticipation of said bonds shall be general obligations of the Town, payable as to both principal and interest by general tax upon all the taxable real property within the Town. The faith and credit of the Town are hereby irrevocably pledged to the punctual payment of the principal of and interest on said bonds and any notes issued in anticipation of the sale of said bonds and provision shall be made annually in the budget of the Town by appropriation for (a) the amortization and redemption of the bonds and any notes in anticipation thereof to mature in such year and (b) the payment of interest to be due and payable in such year.

Section 5. Subject to the provisions of this resolution and of the Law and pursuant to the provisions of Section 21.00 relative to the authorization of bonds with substantially level or declining annual debt service, Section 30.00 relative to the authorization of

the issuance of bond anticipation notes and Section 50.00 and Sections 56.00 to 60.00 and Section 168.00 of the Law, the powers and duties of the Town Board relative to authorizing bond anticipation notes and prescribing the terms, form and contents and as to the sale and issuance of the bonds herein authorized, and of any bond anticipation notes issued in anticipation of said bonds, and the renewals of said bond anticipation notes, and as to the execution of agreements for credit enhancements, are hereby delegated to the Supervisor, the chief fiscal officer of the Town.

Section 6. The validity of the bonds authorized by this resolution, and of any notes issued in anticipation of the sale of said bonds, may be contested only if:

- (a) such obligations are authorized for an object or purpose for which the Town is not authorized to expend money, or
- (b) the provisions of law which should be complied with at the date of the publication of such resolution, or a summary thereof, are not substantially complied with,

and an action, suit or proceeding contesting such validity is commenced within twenty days after the date of such publication, or

- (c) such obligations are authorized in violation of the provisions of the constitution.

Section 7. This bond resolution is subject to a permissive referendum and the Town Clerk is hereby authorized and directed, within ten (10) days after the adoption of this resolution, to cause to be published, in full, in the "*Cheektowaga Bee*," a newspaper having a general circulation within said Town and hereby designated the official newspaper of the Town for such publication and posted on the sign board of the Town maintained pursuant to the Town Law, a Notice in substantially the following form:

TOWN OF CHEEKTOWAGA, NEW YORK

PLEASE TAKE NOTICE that on March 3, 2014, the Town Board of the Town of Cheektowaga, in the County of Erie, New York, adopted a bond resolution entitled:

“Bond Resolution of the Town of Cheektowaga, New York, adopted March 3, 2014, authorizing the reconstruction of various sidewalks in the Town, stating the estimated maximum cost thereof is \$350,000, appropriating said amount for such purpose, and authorizing the issuance of \$350,000 serial bonds of said Town to finance said appropriation,”

an abstract of which bond resolution concisely stating the purpose and effect thereof, being as follows:

FIRST: AUTHORIZING said Town to reconstruct various sidewalks in the Town; STATING the estimated maximum cost thereof, including preliminary costs, and costs incidental thereto and the financing thereof, is \$350,000; APPROPRIATING said amount for such purpose; and STATING the plan of financing includes the issuance of \$350,000 serial bonds of the Town to finance said appropriation, and the levy of a tax upon all the taxable real property within the Town to pay the principal of said bonds and interest thereon;

SECOND: AUTHORIZING the issuance of \$350,000 serial bonds of the Town pursuant to the Local Finance Law of the State of New York (the “Law”) to finance said appropriation;

THIRD: DETERMINING and STATING the period of probable usefulness applicable to the purpose for which said serial bonds are authorized to be issued is ten (10) years; the proceeds of said bonds and any bond anticipation notes issued in anticipation thereof may be applied to reimburse the Town for expenditures made after the effective date of this bond resolution for the purpose for which said bonds are authorized; and the proposed maturity of said \$350,000 serial bonds will exceed five (5) years;

FOURTH: DETERMINING that said bonds and any bond anticipation notes issued in anticipation of said bonds and the renewals of said bond anticipation notes shall be general obligations of the Town; and PLEDGING to their payment the faith and credit of the Town;

FIFTH: DELEGATING to the Supervisor the powers and duties as to the issuance of said bonds and any bond anticipation notes issued in anticipation of said bonds, or the renewals thereof; and

SIXTH: DETERMINING that the bond resolution is subject to a permissive referendum.

DATED: March 3, 2014

Alice Magierski
Town Clerk

Section 8. The Town Clerk is hereby authorized and directed to cause said bond resolution to be published, in summary, after said bond resolution shall take effect, in the newspaper referred to in Section 7 hereof, and hereby designated the official newspaper for said publication, together with a Notice in substantially the form as provided by Section 81.00 of the Local Finance Law, constituting Chapter 33-a of the Consolidated Laws of the State of New York.

* * *

The adoption of the foregoing resolution was seconded by Gerald P. Kaminski and
duly put to a vote on roll call, which resulted as follows:

AYES: Supervisor Holtz; Councilmember James P. Rogowski; Councilmember
Charles Markel; Councilmember Gerald P. Kaminski Sr.; Councilmember Angela
Wozniak; Councilmember Diane Benczkowski

ABSENT: Councilmember Timothy J. Meyers

The resolution was declared adopted.

CERTIFICATE

I, ALICE MAGIERSKI, Town Clerk of the Town of Cheektowaga, in the County of Erie, State of New York, HEREBY CERTIFY that the foregoing annexed extract from the minutes of a meeting of the Town Board of said Town of Cheektowaga duly called and held on March 3, 2014, has been compared by me with the original minutes as officially recorded in my office in the Minute Book of said Town Board and is a true, complete and correct copy thereof and of the whole of said original minutes so far as the same relate to the subject matters referred to in said extract.

IN WITNESS WHEREOF, I have hereunto set my hand and affixed the corporate seal of said Town of Cheektowaga this 3rd day of March, 2014.

(SEAL)

Town Clerk

RESULT:	ADOPTED [UNANIMOUS]
MOVER:	Mary Holtz, Supervisor
SECONDER:	Gerald Kaminski, Councilmember
AYES:	Holtz, Rogowski, Markel, Kaminski, Wozniak, Benczkowski
ABSENT:	Timothy J. Meyers



10. RESOLUTION 2014-147

Bond Resolution for Reconstruction and Resurfacing of Various Town Highways

Sponsored By: Supervisor Holtz, Councilmember Kaminski

BOND RESOLUTION OF THE TOWN OF CHEEKTOWAGA, NEW YORK, ADOPTED MARCH 3, 2014, AUTHORIZING THE PARTIAL RECONSTRUCTION AND RESURFACING OF VARIOUS TOWN HIGHWAYS, STATING THE ESTIMATED MAXIMUM COST THEREOF IS \$2,350,000, APPROPRIATING SAID AMOUNT FOR SUCH PURPOSE, AND AUTHORIZING THE ISSUANCE OF \$2,350,000 SERIAL BONDS OF SAID TOWN TO FINANCE SAID APPROPRIATION

THE TOWN BOARD OF THE TOWN OF CHEEKTOWAGA, IN THE COUNTY OF ERIE, NEW YORK, HEREBY RESOLVES (by the favorable vote of not less than two-thirds of all the members of said Town Board) AS FOLLOWS:

Section 1. The Town of Cheektowaga, in the County of Erie, New York (herein called the "Town"), is hereby authorized to partially reconstruct and resurface various Town highways. The estimated maximum cost thereof, including preliminary costs and costs incidental thereto and the financing thereof, is \$2,350,000 and said amount is hereby appropriated for such purpose. The plan of financing includes the issuance of \$2,350,000 serial bonds of the Town to finance said appropriation, and the levy and collection of taxes on all the taxable real property in the Town to pay the principal of said bonds and the interest thereon as

the same shall become due and payable.

Section 2. Serial bonds of the Town in the principal amount of \$2,350,000 are hereby authorized to be issued pursuant to the provisions of the Local Finance Law, constituting Chapter 33-a of the Consolidated Laws of the State of New York (herein called the "Law"), to finance said appropriation.

Section 3. The following additional matters are hereby determined and declared:

(a) The period of probable usefulness applicable to the object or purpose for which said bonds are authorized to be issued, within the limitations of Section 11.00 a. 20 (c) of the Law, is fifteen (15) years.

(b) The proceeds of the bonds herein authorized and any bond anticipation notes issued in anticipation of said bonds may be applied to reimburse the Town for expenditures made after the effective date of this resolution for the purpose for which said bonds are authorized. The foregoing statement of intent with respect to reimbursement is made in conformity with Treasury Regulation Section 1.150-2 of the United States Treasury Department.

(c) The proposed maturity of the bonds authorized by this resolution will exceed five (5) years.

Section 4. Each of the bonds authorized by this resolution and any bond anticipation notes issued in anticipation of the sale of said bonds shall contain the recital of validity as prescribed by Section 52.00 of the Law and said bonds and any notes issued in anticipation of said bonds shall be general obligations of the Town, payable as to both principal and interest by general tax upon all the taxable real property within the Town. The faith and credit of the Town are hereby irrevocably pledged to the punctual payment of the principal of and interest on said bonds and any notes issued in anticipation of the sale of said bonds and provision shall be made annually in the budget of the Town by appropriation for (a) the

amortization and redemption of the bonds and any notes in anticipation thereof to mature in such year and (b) the payment of interest to be due and payable in such year.

Section 5. Subject to the provisions of this resolution and of the Law and pursuant to the provisions of Section 21.00 relative to the authorization of bonds with substantially level or declining annual debt service, Section 30.00 relative to the authorization of the issuance of bond anticipation notes and Section 50.00 and Sections 56.00 to 60.00 and Section 168.00 of the Law, the powers and duties of the Town Board relative to authorizing bond anticipation notes and prescribing the terms, form and contents and as to the sale and issuance of the bonds herein authorized, and of any bond anticipation notes issued in anticipation of said bonds, and the renewals of said bond anticipation notes, and as to the execution of agreements for credit enhancements, are hereby delegated to the Supervisor, the chief fiscal officer of the Town.

Section 6. The validity of the bonds authorized by this resolution, and of any notes issued in anticipation of the sale of said bonds, may be contested only if:

- (a) such obligations are authorized for an object or purpose for which the Town is not authorized to expend money, or
- (b) the provisions of law which should be complied with at the date of the publication of such resolution, or a summary thereof, are not substantially complied with,

and an action, suit or proceeding contesting such validity is commenced within twenty days after the date of such publication, or

- (c) such obligations are authorized in violation of the provisions of the constitution.

Section 7. This bond resolution is subject to a permissive referendum and the Town Clerk is hereby authorized and directed, within ten (10) days after the adoption of this resolution, to cause to be published, in full, in the "*Cheektowaga Bee*," a newspaper having a

general circulation within said Town and hereby designated the official newspaper of the Town for such publication and posted on the sign board of the Town maintained pursuant to the Town Law, a Notice in substantially the following form:

TOWN OF CHEEKTOWAGA, NEW YORK

PLEASE TAKE NOTICE that on March 3, 2014, the Town Board of the Town of Cheektowaga, in the County of Erie, New York, adopted a bond resolution entitled:

“Bond Resolution of the Town of Cheektowaga, New York, adopted March 3, 2014, authorizing the partial reconstruction and resurfacing of various Town highways, stating the estimated maximum cost thereof is \$2,350,000, appropriating said amount for such purpose, and authorizing the issuance of \$2,350,000 serial bonds of said Town to finance said appropriation,”

an abstract of which bond resolution concisely stating the purpose and effect thereof, being as follows:

FIRST: AUTHORIZING said Town to partially reconstruct and resurface various Town highways; STATING the estimated maximum cost thereof, including preliminary costs, and costs incidental thereto and the financing thereof, is \$2,350,000; APPROPRIATING said amount for such purpose; and STATING the plan of financing includes the issuance of \$2,350,000 serial bonds of the Town to finance said appropriation, and the levy of a tax upon all the taxable real property within the Town to pay the principal of said bonds and interest thereon;

SECOND: AUTHORIZING the issuance of \$2,350,000 serial bonds of the Town pursuant to the Local Finance Law of the State of New York (the “Law”) to finance said appropriation;

THIRD: DETERMINING and STATING the period of probable usefulness applicable to the purpose for which said serial bonds are authorized to be issued is fifteen (15) years; the proceeds of said bonds and any bond anticipation notes issued in anticipation thereof may be applied to reimburse the Town for expenditures made after the effective date of this bond resolution for the purpose for which said bonds are authorized; and the proposed maturity of said \$2,350,000 serial bonds will exceed five (5) years;

FOURTH: DETERMINING that said bonds and any bond anticipation notes issued in anticipation of said bonds and the renewals of said bond anticipation notes shall be general obligations of the Town; and PLEDGING to their payment the faith and credit of the Town;

FIFTH: DELEGATING to the Supervisor the powers and duties as to the issuance of said bonds and any bond anticipation notes issued in anticipation of said bonds, or the renewals thereof; and

SIXTH: DETERMINING that the bond resolution is subject to a permissive referendum.

DATED: March 3, 2014

Alice Magierski
Town Clerk

Section 8. The Town Clerk is hereby authorized and directed to cause said bond resolution to be published, in summary, after said bond resolution shall take effect, in the newspaper referred to in Section 7 hereof, and hereby designated the official newspaper for said publication, together with a Notice in substantially the form as provided by Section 81.00 of the Local Finance Law, constituting Chapter 33-a of the Consolidated Laws of the State of New York.

* * *

The adoption of the foregoing resolution was seconded by Gerald P. Kaminski and
duly put to a vote on roll call, which resulted as follows:

AYES: Supervisor Holtz; Councilmember James P. Rogowski; Councilmember
Charles Markel; Councilmember Gerald P. Kaminski Sr.; Councilmember Angela
Wozniak; Councilmember Diane Benczkowski

ABSENT: Councilmember Timothy J. Meyers

The resolution was declared adopted.

CERTIFICATE

I, ALICE MAGIERSKI, Town Clerk of the Town of Cheektowaga, in the County of Erie, State of New York, HEREBY CERTIFY that the foregoing annexed extract from the minutes of a meeting of the Town Board of said Town of Cheektowaga duly called and held on March 3, 2014, has been compared by me with the original minutes as officially recorded in my office in the Minute Book of said Town Board and is a true, complete and correct copy thereof and of the whole of said original minutes so far as the same relate to the subject matters referred to in said extract.

IN WITNESS WHEREOF, I have hereunto set my hand and affixed the corporate seal of said Town of Cheektowaga this 3rd day of March, 2014.

(SEAL)

Alice Magierski, Town Clerk

RESULT:	ADOPTED [UNANIMOUS]
MOVER:	Mary Holtz, Supervisor
SECONDER:	Gerald Kaminski, Councilmember
AYES:	Holtz, Rogowski, Markel, Kaminski, Wozniak, Benczkowski
ABSENT:	Timothy J. Meyers



11. RESOLUTION 2014-148

Authorization for Purchase - Ammunition

Sponsored By: Councilmember Benczkowski, Councilmember Kaminski

WHEREAS, the Cheektowaga Police Department, in an effort to best prepare our police officers to serve the public while insulating the Town from liability, AND

WHEREAS, police officers are required to train and qualify yearly with the three (3) weapons systems that they use in the performance of their duties, AND

WHEREAS, the Police Department is in need of replenishing their ammunition supply for the SWAT and Patrol Divisions, AND

WHEREAS, Eagle Point Gun/TJ Morris & Son offers ammunition under New York State Contract #PC66334, AND

WHEREAS, money has been appropriated for this purchase out of budget line 100-3120-4091, NOW, THEREFORE, BE IT

RESOLVED, that the Town Board hereby authorizes the purchase of ammunition at a total cost of \$34,231.12 from:

Eagle Point Gun/TJ Morris & Son
1707 Third Street
Thorofare, New Jersey 08086

RESULT:	ADOPTED [UNANIMOUS]
MOVER:	Diane Benczkowski, Councilmember
SECONDER:	Gerald Kaminski, Councilmember
AYES:	Holtz, Rogowski, Markel, Kaminski, Wozniak, Benczkowski
ABSENT:	Timothy J. Meyers



12. RESOLUTION 2014-149

Unsafe-Unsecured/39 Wayne Terr

Sponsored By: Councilmember Markel, Supervisor Holtz

WHEREAS, Town of Cheektowaga Law for the Administration and Enforcement of the Codes of New York State; and the Property Maintenance Code of New York State require that all vacant structures and premises shall be maintained in clean, safe, secure and sanitary conditions so as not to cause a blighting problem or adversely affect the public health or safety and all nuisances abated, AND

WHEREAS, the Town of Cheektowaga has received notification of an unsafe structure and premises located at 39 Wayne Terr, Cheektowaga, New York SBL# 80.17-4-54 that is a danger to the safety of others, and records kept by the Assessors Office identify Megan A. Tennent, 39 Wayne Terr., Cheektowaga, New York 14225, as the owner AND

WHEREAS, an inspection of such premises was conducted at 39 Wayne Terr., by the Housing and Neighborhood Preservation Office, AND

WHEREAS, such inspection found the premises to be deteriorated, vacant, a hazard, and a danger to the safety and well being of others, AND

WHEREAS, the Town of Cheektowaga Housing and Neighborhood Preservation Office properly notified the property owner in accordance with the Town of Cheektowaga Law for the Administration and Enforcement of the Codes of New York State, and the owner failed to take actions to safeguard the premises, AND

WHEREAS, these conditions require the Town of Cheektowaga Housing and Neighborhood Preservation Office to take immediate steps to safeguard the premises to protect the health and safety of others and abate all nuisances, NOW, THEREFORE BE IT

RESOLVED, that pursuant to Section 70-7A.(5) and Section 70-8 of the Town of Cheektowaga Law for the Administration and Enforcement of the Codes of New York State that the vacant structure premises be safeguarded and all nuisances abated; and all costs incurred be assessed against the property hereinbefore described.

RESULT:	ADOPTED [UNANIMOUS]
MOVER:	Charles Markel, Councilmember
SECONDER:	Mary Holtz, Supervisor
AYES:	Holtz, Rogowski, Markel, Kaminski, Wozniak, Benczkowski
ABSENT:	Timothy J. Meyers



13. RESOLUTION 2014-150

Youth & Recreation Termination

Sponsored By: Councilmember Wozniak, Councilmember Rogowski

BE IT RESOLVED that the individuals listed below be and herby are terminated in the Department of Youth & Recreational Services effective as indicated:

Hilary Peacock

3/16/13

14225

Motion by Councilmember Markel; Seconded by Councilmember Rogowski to waive the reading of names for the following three (3) resolutions: 2014-150, 2014-151 and 2014-152. Motion carried.

RESULT: **ADOPTED [UNANIMOUS]**

MOVER: Angela M. Wozniak, Councilmember

SECONDER: James P. Rogowski, Councilmember

AYES: Holtz, Rogowski, Markel, Kaminski, Wozniak, Benczkowski

ABSENT: Timothy J. Meyers



14. RESOLUTION 2014-151

Youth & Recreation Hiring

Sponsored By: Councilmember Wozniak, Councilmember Rogowski

BE IT RESOLVED that the individuals listed below be and hereby are hired, as indicated, in the Department of Youth & Recreational Services, effective immediately:

Recreation Attendant - 7140.1611 - \$8.00 - Regular Part-time

Jenna Brewer

14206

RESULT:	ADOPTED [UNANIMOUS]
MOVER:	Angela M. Wozniak, Councilmember
SECONDER:	James P. Rogowski, Councilmember
AYES:	Holtz, Rogowski, Markel, Kaminski, Wozniak, Benczkowski
ABSENT:	Timothy J. Meyers



15. RESOLUTION 2014-152

Hiring/Termination of Part Time Employees

Sponsored By: Councilmember Kaminski, Supervisor Holtz

BE IT RESOLVED, that the following individuals be and hereby are hired as **PART-TIME EMPLOYEES** in the departments listed, not to exceed nineteen (19) hours on a weekly basis, in compliance with Civil Service Laws and Regulations as well as the provisions of the Town's collective bargaining agreement between the Town of Cheektowaga and the Town of Cheektowaga Employees Association:

SANITATION DEPARTMENT Clerk \$10.00/hour effective 2/18/14
Geoffrey C. Schall, Cheektowaga, New York

POLICE DEPARTMENT Police Attendant \$15.00/hour effective 3/4/13
Melanie A. Dingeldey, Sloan, New York

BE IT RESOLVED, that the following employees' salaries be adjusted as follows:

POLICE DEPARTMENT Police Attendant (from \$14.00/hour to \$15.00/hour) effective 1/7/14
Susan Bull, Cheektowaga, New York

JUSTICE COURT Clerk (from \$8.50/hour to \$9.00/hour) effective 3/3/14
Jill M. Baszczynski, Cheektowaga, New York
Faye H. Delano, Cheektowaga, New York
Lynn M. Imiola, Cheektowaga, New York
William V. Matalonis, Cheektowaga, New York
Christine A. Witkowski, Cheektowaga, New York

BE IT RESOLVED, that the following employee be transferred as follows:

CENTRAL RECORDS Clerk (Grant) (from Seasonal to Part Time) \$15.00/hour effective 4/1/14
Carol Bruner, Cheektowaga, New York

BE IT RESOLVED, that the following employee's department be and hereby is amended as follows:

HIGHWAY DEPARTMENT to BUILDING & PLUMBING Clerk \$9.25/hour effective 1/1/14
Genevieve Fronczak, Cheektowaga, New York

RESULT:	ADOPTED [UNANIMOUS]
MOVER:	Gerald Kaminski, Councilmember
SECONDER:	Mary Holtz, Supervisor
AYES:	Holtz, Rogowski, Markel, Kaminski, Wozniak, Benczkowski
ABSENT:	Timothy J. Meyers



16. RESOLUTION 2014-153

Student Intern's Name (Police Department) Corrected from Bridget A. Smith to Bridget A. Stith

Sponsored By: Councilmember Kaminski, Supervisor Holtz

WHEREAS, Bridget A. Stith of Buffalo, New York, (a student at Medaille College) was to be approved to participate in an internship within the Town of Cheektowaga Police Department at the February 19, 2014 Town Board Meeting; AND

WHEREAS, said intern's name appeared incorrectly on the resolution as Bridget A. Smith and must be corrected; NOW, THEREFORE, BE IT

RESOLVED, that Bridget A. Stith of Buffalo, New York, be and hereby is authorized to participate as an unpaid intern in the Police Department, subject to her execution of a Waiver of Liability and Agreement of Confidentiality; AND, BE IT FURTHER

RESOLVED, that her internship be and hereby is effective February 20, 2014 through May 31, 2014; AND, BE IT FURTHER

RESOLVED, that the Town Supervisor be and hereby is authorized and directed to execute the Agreement of Confidentiality, and all other documents necessary to effectuate this student's internship in the Police Department.

RESULT:	ADOPTED [UNANIMOUS]
MOVER:	Gerald Kaminski, Councilmember
SECONDER:	Mary Holtz, Supervisor
AYES:	Holtz, Rogowski, Markel, Kaminski, Wozniak, Benczkowski
ABSENT:	Timothy J. Meyers



17. RESOLUTION 2014-154

Travel Authorization Police Department - Empire State Law Enforcement Traffic Safety Conference - Police Officers Michael McDonough and Scott Scharlau

Sponsored By: Councilmember Kaminski, Supervisor Holtz

WHEREAS, the Empire State Law Enforcement Traffic Safety Conference is being held April 8 through April 9, 2014 in Albany, New York; AND

WHEREAS, Police Officers Michael McDonough and Scott Scharlau have been recommended to attend said conference; AND

WHEREAS, Police Chief David Zack has submitted a request for travel authorization along with the proper paperwork in a timely manner; AND

WHEREAS, the total cost to the Town shall not exceed \$402; AND

WHEREAS, these expenses have been budgeted by the Department; NOW, THEREFORE, BE IT

RESOLVED, that Police Officers Michael McDonough and Scott Scharlau be and hereby are authorized to attend the Empire State Law Enforcement Traffic Safety Conference being held April 8 through April 9, 2014 in Albany, New York.

RESULT:	ADOPTED [UNANIMOUS]
MOVER:	Gerald Kaminski, Councilmember
SECONDER:	Mary Holtz, Supervisor
AYES:	Holtz, Rogowski, Markel, Kaminski, Wozniak, Benczkowski
ABSENT:	Timothy J. Meyers



18. RESOLUTION 2014-155

Travel Authorization Police Department - 2014 Child Abuse Conference - Captain Michael Isbrandt and Lieutenant Kenneth Rusin

Sponsored By: Councilmember Kaminski, Supervisor Holtz

WHEREAS, the 2014 Child Abuse Conference is being held March 19 through March 21, 2014 in Niagara Falls, Ontario, Canada; AND

WHEREAS, Captain Michael Isbrandt and Lieutenant Kenneth Rusin have been recommended to attend said conference; AND

WHEREAS, Police Chief David Zack has submitted a request for travel authorization along with the proper paperwork in a timely manner; AND

WHEREAS, the total cost to the Town shall not exceed \$734; AND

WHEREAS, these expenses have been budgeted by the Department; NOW, THEREFORE, BE IT

RESOLVED, that Captain Michael Isbrandt and Lieutenant Kenneth Rusin be and hereby are authorized to attend the 2014 Child Abuse Conference being held March 19 through March 21, 2014 in Niagara Falls, Ontario, Canada.

RESULT:	ADOPTED [UNANIMOUS]
MOVER:	Gerald Kaminski, Councilmember
SECONDER:	Mary Holtz, Supervisor
AYES:	Holtz, Rogowski, Markel, Kaminski, Wozniak, Benczkowski
ABSENT:	Timothy J. Meyers



19. RESOLUTION 2014-156

Travel Authorization Police Department - Supervising Patrol Critical Incidents - Sergeant Laurie Ucasz

Sponsored By: Councilmember Kaminski, Supervisor Holtz

WHEREAS, a Supervising Patrol Critical Incidents Seminar is being held April 7 through April 8, 2014 in Poughkeepsie, New York; AND

WHEREAS, Sergeant Laurie Ucasz has been recommended to attend said seminar; AND

WHEREAS, Police Chief David Zack has submitted a request for travel authorization along with the proper paperwork in a timely manner; AND

WHEREAS, the total cost to the Town shall not exceed \$853; AND

WHEREAS, these expenses have been budgeted by the Department; NOW, THEREFORE, BE IT

RESOLVED, that Sergeant Laurie Ucasz be and hereby is authorized to attend the Supervising Patrol Critical Incidents Seminar being held April 7 through April 8, 2014 in Poughkeepsie, New York.

RESULT:	ADOPTED [UNANIMOUS]
MOVER:	Gerald Kaminski, Councilmember
SECONDER:	Mary Holtz, Supervisor
AYES:	Holtz, Rogowski, Markel, Kaminski, Wozniak, Benczkowski
ABSENT:	Timothy J. Meyers

IV. Suspension of Rules

Motion by Councilmember Markel; Seconded by Councilmember Rogowski to Suspend the Rules to Include the Following (1) Resolution: 2014-157. Motion Carried.



1. RESOLUTION 2014-157

Award of Demolition Contract for 1007 Walden Avenue

Sponsored By: Councilmember Markel, Supervisor Holtz

WHEREAS, the Town is the owner of property located at 1007 Walden, and

WHEREAS, the above said property was deemed to be in a dilapidated condition, and

WHEREAS, federal Community Development Block Grant Program funds were awarded to the Town by the U.S. Department of Housing and Urban Development to assist with various community development and rehabilitation projects, including the acquisition and demolition of dilapidated property, and

WHEREAS, a Notice to Bidders was published for the asbestos abatement and demolition of the above said property, and

WHEREAS, as a result of said Notice to Bidders, bids were received and duly opened on January 29, 2014 for the furnishing of equipment, operators and laborers for asbestos abatement and demolition of said property, and

WHEREAS, said bids were reviewed by the Director of Community Development and the Town Attorney, and it has been recommended that contracts be awarded to the lowest responsible bidders indicated below, NOW, THEREFORE, BE IT

RESOLVED, that ARIA Contracting Corp, Inc., 3907 North Buffalo Road, Orchard Park, New York 14127, be and hereby is awarded a contract for asbestos abatement and demolition of 1007 Walden Avenue for the amount of \$13,692.00; and, BE IT FURTHER

RESOLVED, that the Supervisor, on behalf of this Town Board, be and hereby is directed and authorized to execute any and all documents in connection with same, and, BE IT FURTHER

RESOLVED, that said asbestos abatement and demolition costs shall be chargeable to the CDBG Clearance/Demolition Account Number 700-1012-0602.

RESULT:	ADOPTED [UNANIMOUS]
MOVER:	Charles Markel, Councilmember
SECONDER:	Mary Holtz, Supervisor
AYES:	Holtz, Rogowski, Markel, Kaminski, Wozniak, Benczkowski
ABSENT:	Timothy J. Meyers

V. Communications

A. Departmental Communications

1. **Building Permit List - February 2014**
2. **Minutes: Cheektowaga Traffic Safety Commission - January 21, 2014**

B. General Communications

1. **Summons & Complaint: Ghazanfar Iqbal vs. Town of Cheektowaga**
2. **Notice of Claim: Daniel Sieber vs. Town of Cheektowaga**
3. **Notice of Claim: Lyn Clark vs. Town of Cheektowaga**

VI. Comments

A. Supervisor's Comments

B. Councilmember's Comments

C. Public Comments

VII. Adjournment

Motion by Councilmember Rogowski; Seconded by Supervisor Holtz to adjourn the meeting at 7:12 PM

Alice Magierski, Town Clerk

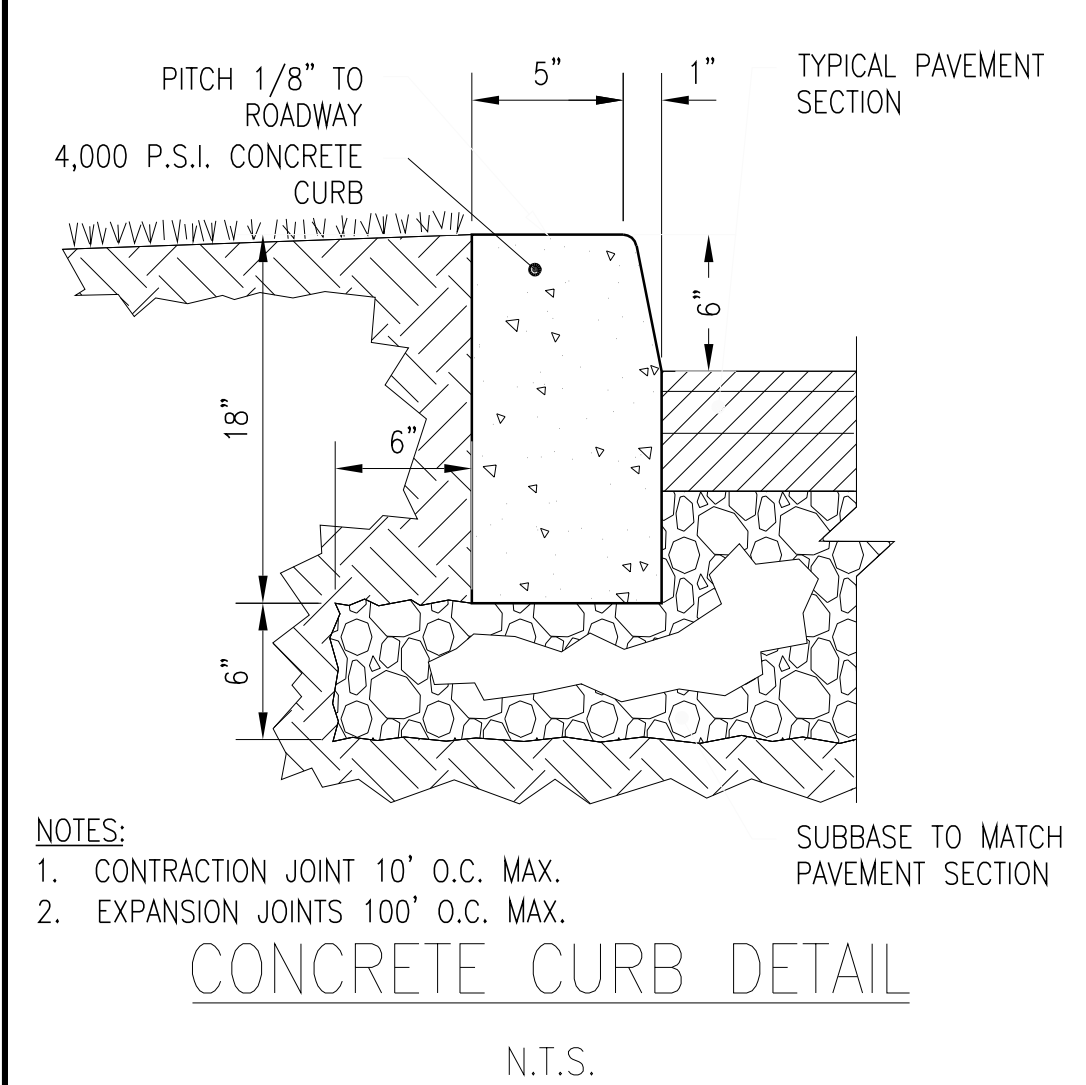
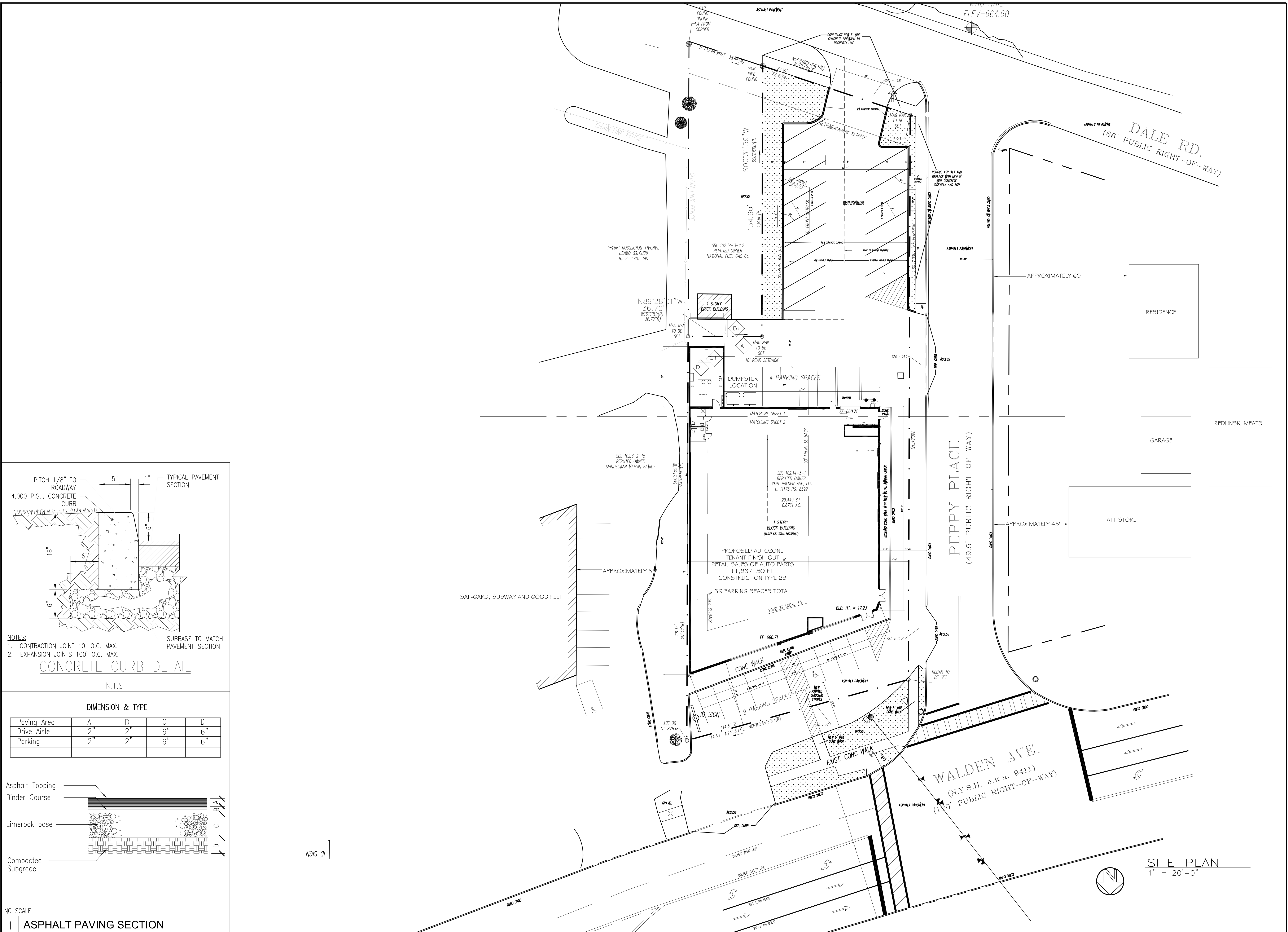

DIMENSION & TYPE

Paving Area	A	B	C	D
Drive Aisle	2"	2"	6"	6"
Parking	2"	2"	6"	6"

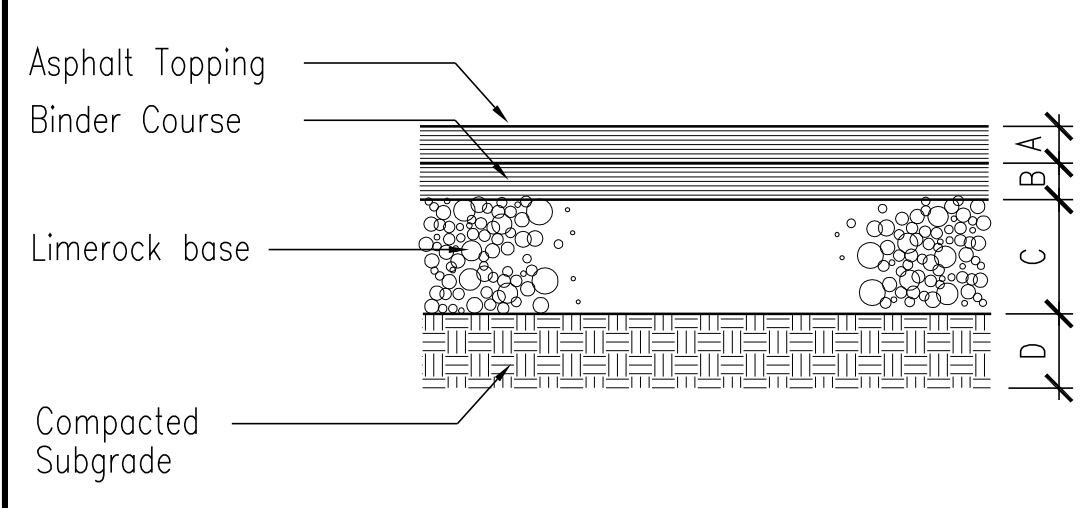

NO SCALE
1 ASPHALT PAVING SECTION

REVISIONS

NO.	DESCRIPTION	DATE
1	12-11-13 planning submittal	4
2	12-20-13 planning comments sidewalks	5
3		6

AutoZone Store No. 4759
1601 WALDEN AVE
CHEEKTOWAGA NY 14225
SITE PLAN / NOTES / DETAILS

Architect: LEW ELLIS
123 South Front Street
Memphis, Tennessee 38103
TEL: 901-495-8994 FAX: (901) 495-8969
For Bidding & Contractor Information Contact:
McGraw - Hill Construction Tel. 615-884-1017
www.construction.com

11-22-13
7N
C-1

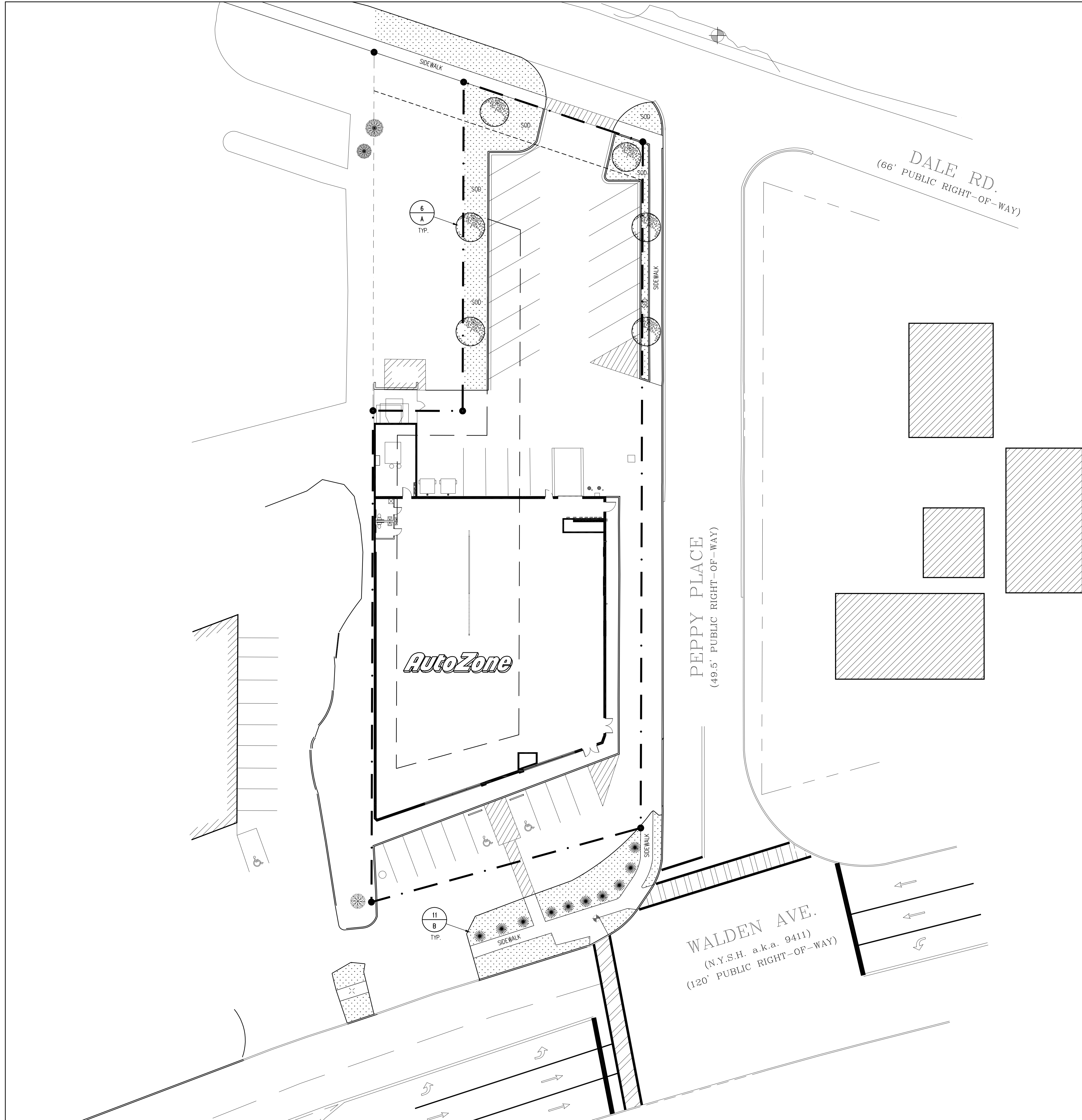

LANDSCAPE LEGEND

Ivory Silk Lilac 2.5" Calip. -Type 'A'

Sea Green Juniper 3-5' Height x 5-6' Spread -Type 'B'

Sod See specifications

Quantity 1
Type A

GENERAL NOTES

- All landscape areas to be sod common to region except where other plant material is called for.
- All trees and shrubs to be planted in mulch beds with edge strips to separate turf grass areas.
- Sod to extend from property lines to back of city sidewalks and/or curbs.
- For any landscape area so designated to remain whether on or off site, remove weeds, rocks, construction items, etc., then scarify area, reseed, and fertilize. R.O.W. curb and gutters are to be cleaned of debris.
- Finished grades in landscape islands shall be installed so that they are 1" lower than the top of the surrounding curb.
- PROVIDE A WEED MAT FOR ALL PLANTING AREAS!!!

PLANT LIST

QUANTITY	KEY	BOTANICAL / COMMON NAME	SIZE	ROOT TYPE	REMARKS
6	A	BOTANICAL - SYRINGA RETICULATA COMMON NAME - Ivory Silk Lilac	2.5" CAL.	B & B	
10	B	BOTANICAL - JUNIPERUS CHINENSIS COMMON NAME - Sea Green Juniper	3-5' Height 5-6' Spread	B & B	

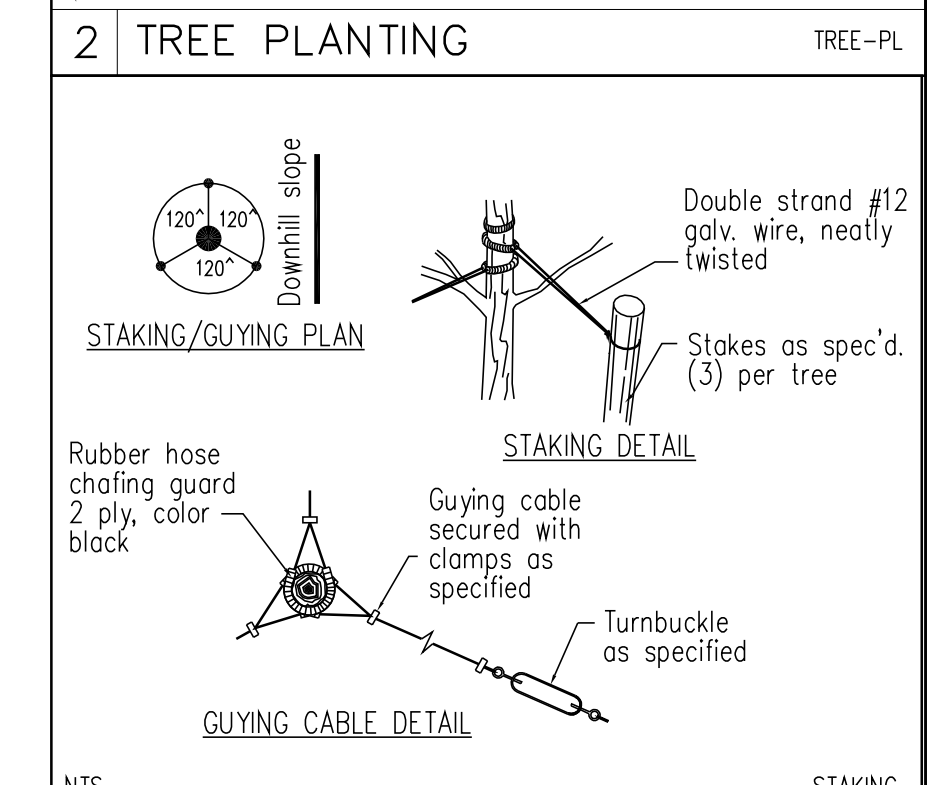
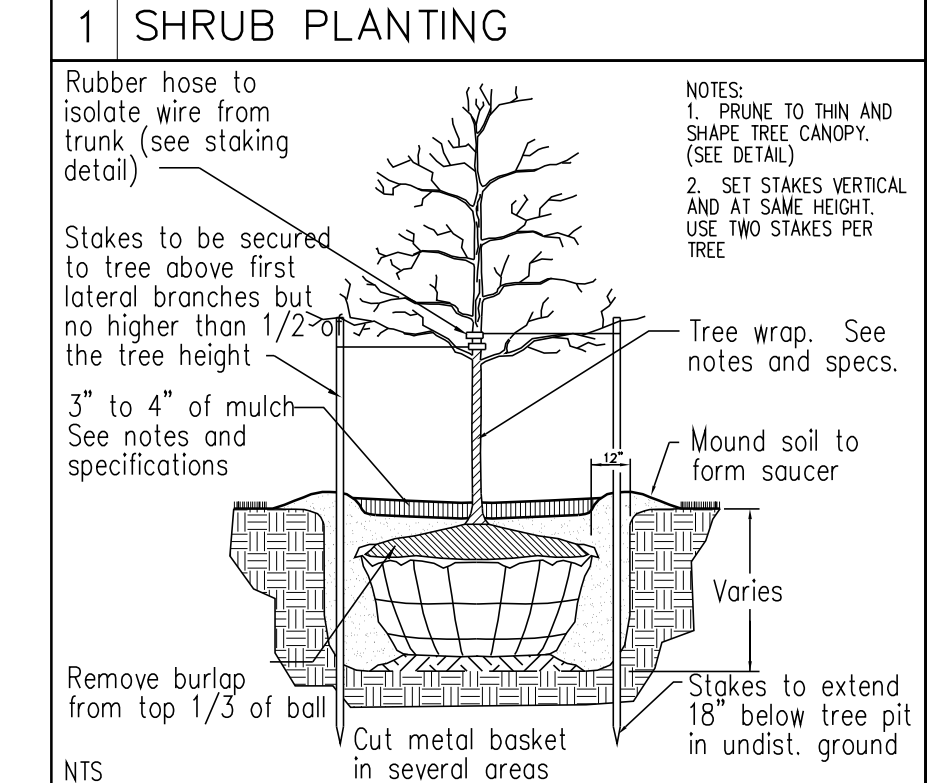
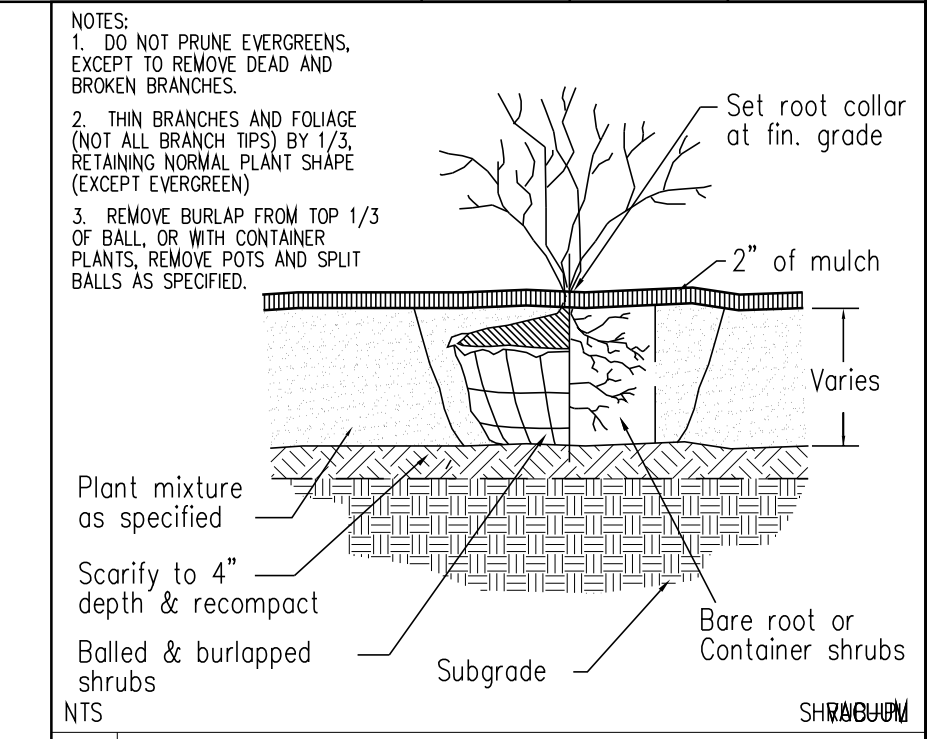

OWNER: **AutoZone, Inc.**
123 S. FRONT STREET, 3rd FLOOR
MEMPHIS, TENNESSEE 38103

PREPARED FOR: **AutoZone STORE DEVELOPMENT**
Store No.: 4759
1601 WALDEN AVENUE
CHEEKTOWAGA NY 14225

SCALE: 1" = 20'-0"

REVISIONS

1.	
2.	
3.	
4.	
5.	
6.	
7.	

ARCHITECT: L.E.
DRAFTSMAN: S.W.
CHECKED BY: C.T.
DATE: 12-17-13
PROTOTYPE SIZE: 7N

L1.0



Town of Cheektowaga

Work Session

~ Minutes ~

3301 Broadway
Cheektowaga, NY 14227
<http://www.town.cheektowaga.ny.us>

Alice Magierski
716-686-3400

Tuesday, March 11, 2014

6:00 PM

Council Office

I. Call to Order

6:00 PM Meeting called to order on March 11, 2014 at Council Office, Conference Room, Cheektowaga, NY.

Attendee Name	Organization	Title	Status	Arrived
Mary Holtz	Town of Cheektowaga	Supervisor	Absent	
James P. Rogowski	Town of Cheektowaga	Councilmember	Present	
Charles Markel	Town of Cheektowaga	Councilmember	Present	
Gerald Kaminski	Town of Cheektowaga	Councilmember	Present	
Angela M. Wozniak	Town of Cheektowaga	Councilmember	Present	
Diane Benczkowski	Town of Cheektowaga	Councilmember	Present	
Timothy J. Meyers	Town of Cheektowaga	Councilmember	Present	

II. Motion To: Enter Into Executive Session

COMMENTS - Current Meeting:

To discuss Personnel matters.

RESULT: ADOPTED [UNANIMOUS]
MOVER: Charles Markel, Councilmember
SECONDER: Timothy J. Meyers, Councilmember
AYES: Rogowski, Markel, Kaminski, Wozniak, Benczkowski, Meyers
ABSENT: Mary Holtz

III. Motion To: Exit Executive Session

RESULT: ADOPTED [UNANIMOUS]
MOVER: James P. Rogowski, Councilmember
SECONDER: Gerald Kaminski, Councilmember
AYES: Rogowski, Markel, Kaminski, Wozniak, Benczkowski, Meyers
ABSENT: Mary Holtz

IV. Resolutions



1. RESOLUTION 2014-158

Authorize Supervisor to Execute Agreement

Sponsored By: Councilmember Benczkowski, Councilmember Kaminski

WHEREAS, the Town is desirous of retaining an outside firm to perform an audit and related testing of the Town's computer networks; and

WHEREAS, said work and testing have previously been recommended by outside auditors to assure the integrity of the Town's electronic data; and

WHEREAS, UberGuard Information Security Consulting, LLC ("UberGuard") has submitted a proposal for said services; and

WHEREAS, moneys are available for said services; NOW, THEREFORE, BE IT

RESOLVED, that the Town hereby retains UberGuard Information Security Consulting, LLC for the aforesaid services pursuant to an agreement between the Town and UberGuard, and BE IT FURTHER

RESOLVED, that the Supervisor is hereby authorized to execute said agreement with UberGuard, subject to approval by the Town Attorney; and BE IT FURTHER

RESOLVED, that funds shall be allocated from budget line item number 100.1680.2204.

RESULT:	ADOPTED [UNANIMOUS]
MOVER:	Diane Benczkowski, Councilmember
SECONDER:	Gerald Kaminski, Councilmember
AYES:	Rogowski, Markel, Kaminski, Wozniak, Benczkowski, Meyers
ABSENT:	Mary Holtz

V. Work Session Ends at 7:25 PM



Town of Cheektowaga

Regular Meeting

~ Minutes ~

3301 Broadway
Cheektowaga, NY 14227
<http://www.town.cheektowaga.ny.us>

Alice Magierski
716-686-3400

Monday, March 17, 2014

6:45 PM

Council Chambers

I. Call to Order

6:45 PM Meeting called to order on March 17, 2014 at Council Chambers, 3301 Broadway St, Cheektowaga, NY.

Attendee Name	Organization	Title	Status	Arrived
Mary Holtz	Town of Cheektowaga	Supervisor	Present	
James P. Rogowski	Town of Cheektowaga	Councilmember	Present	
Charles Markel	Town of Cheektowaga	Councilmember	Present	
Gerald Kaminski	Town of Cheektowaga	Councilmember	Present	
Angela M. Wozniak	Town of Cheektowaga	Councilmember	Present	
Diane Benczkowski	Town of Cheektowaga	Councilmember	Present	
Timothy J. Meyers	Town of Cheektowaga	Councilmember	Present	

2. Additional Attendees

Robert Brandon, Zoning Board Chairman
Brian Krause, Director of Finance and Administration
William Pugh, Town Engineer
Kevin Schenk, Town Attorney

II. Public Comment Period

III. Public Hearing

1. Bond Hearing for District Improvements - Replacement of Sanitary Sewers

RESULT: CLOSED [UNANIMOUS]
MOVER: Mary Holtz, Supervisor
SECONDER: Gerald Kaminski, Councilmember
AYES: Holtz, Rogowski, Markel, Kaminski, Wozniak, Benczkowski, Meyers

IV. Resolutions



1. RESOLUTION 2014-159

Transfer of Funds-2013

Sponsored By: Councilmember Kaminski, Supervisor Holtz

BE IT RESOLVED, that the following transfer is hereby approved and made part hereof;

GENERAL

FROM:	100.9010.8141	Medical Insurance	\$4,018,829.00
	100.9010.8143	Retiree Medical Insurance	3,104,589.00
	100.1315.4001	Office Supplies	32.00
	100.1910.4591	NSP Program	41,671.00
	100.9010.8101	Employee Retirement	3,912.00
	100.3020.1908	Training	7,051.00
	100.3510.4093	Training	641.00
	100.7110.4001	Office Supplies	27.00
	100.7310.4674	Teen Center Expense	342.00
TO:	100.9903.8141	Transfer-Medical Insurance	\$4,018,829.00
	100.9903.8143	Transfer-Retiree Medical Insurance	3,104,589.00
	100.1685.2000	Equipment	32.00
	100.1910.4721	NSP Program	41,671.00
	100.3020.4022	Maintenance Contract	1,037.00
	100.3020.4203	Cellular Phones	7,654.00
	100.3020.4431	Equipment Repairs	2,272.00
	100.3510.4432	Repairs & Maintenance	641.00
	100.7110.2201	Office Equipment	27.00
	100.7310.4001	Office Supplies	342.00

SANITATION

FROM:	150.8160.8141	Medical Insurance	\$464,805.00
	150.8160.8143	Retiree Medical Insurance	435,449.00
	150.8160.4469	Landfill Costs	73,481.00
TO:	150.9903.8141	Transfer-Medical Insurance	\$530,819.00
	150.9903.8143	Transfer-Retiree Medical Insurance	442,916.00

SPECIAL DISTRICTS

FROM:	255.8125.8141	Medical Insurance	\$251,497.00
	255.8125.8143	Retiree Medical Insurance	242,175.00
	255.8135.8141	Medical Insurance	142,877.00
	255.8135.8143	Retiree Medical Insurance	49,069.00
TO:	255.9903.8141.8125	Transfer-Medical Insurance	\$251,497.00
	255.9903.8143.8125	Transfer-Retiree Medical Insurance	242,175.00
	255.9903.8141.8135	Transfer-Medical Insurance	154,708.00
	255.9903.8143.8135	Transfer-Retiree Medical Insurance	37,238.00

HIGHWAY

FROM:	300.9010.8141	Medical Insurance	\$899,801.00
	300.9010.8143	Retiree Medical Insurance	389,496.00

	300.5141.1731	Less Labor Allocation	95,032.45
	300.5130.1701	Highway Machinery	79,673.02
	300.5140.1379	Brush & Weed	233.79
	300.5141.1734	Less Labor Brush & Weed	87,934.95
	300.5142.1701	Snow Removal	140,143.59
	300.5148.1701	Other Governments	19,673.35
	300.5141.1737	Less Labor Improvements	50,500.58
TO:	300.9903.8141	Transfer-Medical Insurance	\$899,801.00
	300.9903.8143	Transfer-Retiree Medical Insurance	389,496.00
	300.5110.1701	Regular Payroll	95,032.45
	300.5141.1733	Overtime Payroll	79,673.02
	300.5141.1734	Network Hardware	88,168.74
	300.5141.1735	Computer Hardware	140,143.59
	300.5141.1736	Office Supplies	19,673.35
	300.5150.1701	Travel, Training & Conferences	50,500.58
CDBG			
FROM:	700.1013.0600	Housing Rehab.- Single Family	\$49,616.12
TO:	700.1013.0752	Rehab Activity Delivery Costs	\$49,616.12
RISK RETENTION			
FROM:	101.1910.2415	Employee Contr. To Health Premium	\$338,578.00
	101.1910.5032	Health Insurance Transfers In	10,399,259.00
TO:	101.1933.4703	Health Insurance Expenses	\$10,737,837.00
PART TOWN			
FROM:	800.3620.2770	Permits & Inspections	\$6,773.00
	800.3620.4001	Office Supplies	338.00
	800.9010.8141	Medical Insurance	243,208.00
	800.9010.8143	Retiree Medical Insurance	83,988.00
TO:	800.3620.1901	Regular Payroll	\$6,773.00
	800.3620.2201	Office Equipment	338.00
	800.9903.8141	Transfer-Medical Insurance	247,383.00
	800.9903.8143	Transfer-Retiree Medical Insurance	79,813.00

RESULT:	ADOPTED [UNANIMOUS]
MOVER:	Gerald Kaminski, Councilmember
SECONDER:	Mary Holtz, Supervisor
AYES:	Holtz, Rogowski, Markel, Kaminski, Wozniak, Benczkowski, Meyers



2. RESOLUTION 2014-160

Warrant

Sponsored By: Supervisor Holtz, Councilmember Kaminski

BE IT RESOLVED, that the following Vouchers & Warrants submitted to the Town of Cheektowaga prior to March 17, 2014 are hereby approved and made part hereof;

GENERAL FUND	\$512,989.79
RISK RETENTION FUND	23,261.49
NYS HOME PROGRAM	
DEBT	
HUD HOUSING REHABILITATION FUND	986.04
SPECIAL DISTRICTS FUND	183,287.64
HIGHWAY FUND	52,110.50
CAPITAL FUND	3,598.99
TRUST & AGENCY FUND	11,844.25
HUD CDBG FUND	208.61
PART TOWN FUND	29,395.00
NYS AFFORDABLE HOUSING	
	\$817,682.31

RESULT:	ADOPTED [UNANIMOUS]
MOVER:	Mary Holtz, Supervisor
SECONDER:	Gerald Kaminski, Councilmember
AYES:	Holtz, Rogowski, Markel, Kaminski, Wozniak, Benczkowski, Meyers



3. RESOLUTION 2014-161

Resolution and Order After Public Hearing for Sewer Bonding

Sponsored By: Supervisor Holtz, Councilmember Kaminski

At a meeting of the Town Board of the Town of Cheektowaga, in the County of Erie, New York, held at the Town Hall, 3301 Broadway, Cheektowaga, New York, on the 17th day of March, 2014.

PRESENT:

- Hon. Mary F. Holtz, Supervisor
- James P. Rogowski, Councilmember
- Charles C. Markel, Councilmember
- Gerald P. Kaminski, Sr. Councilmember
- Angela M. Wozniak, Councilmember
- Diane M. Benczkowski, Councilmember
- Timothy J. Meyers, Councilmember

In the Matter of the

Increase and Improvement of Facilities of the Consolidated Sewer District, in the Town of Cheektowaga, in the County of Erie, New York, pursuant to Section 202-b of the Town Law

Offered by: Supervisor Mary F. Holtz

Seconded by: Councilmember Gerald P. Kaminski, Sr.

RESOLUTION AND
ORDER AFTER PUBLIC
HEARING

WHEREAS, the Town Board of the Town of Cheektowaga (herein called the “Town Board” and the “Town”, respectively), in the County of Erie, New York, on behalf of the

Consolidated Sewer District, in the Town (herein referred to as the “District”), has proposed an increase and improvement of facilities of the District, consisting of the replacement of various sanitary sewers at the estimated maximum cost of \$700,000; and

WHEREAS, the Town Board adopted an Order describing in general terms the proposed increase and improvement of such facilities, specifying the estimated cost thereof, and stating the Town Board would meet to hear all persons interested in said increase and improvement of facilities on March 17, 2014 at 6:45 o’clock P.M. (Prevailing Time) at the Town Hall, 3301 Broadway, Cheektowaga, New York; and

WHEREAS, a Notice of such public hearing was duly published and posted pursuant to the provisions of Article 12 of the Town Law; and

WHEREAS, such public hearing was duly held by the Town Board on this 17th day of March, 2014 at 6:45 o’clock P.M. (Prevailing Time) at the Town Hall, 3301 Broadway, Cheektowaga, New York, with considerable discussion on the matter having been had and all persons desiring to be heard having been heard, including those in favor of and those in opposition to said increase and improvement of such facilities; and

WHEREAS, the Town Board, as lead agency, has given due consideration to the impact that such increase and improvement of facilities may have on the environment and has determined that the proposed project is a Type II action pursuant to the State Environmental Quality Review Act (SEQRA), constituting Article 8 of the Environmental Conservation Law, and 6 N.Y.C.R.R., Regulations Part 617 and no further action is required pursuant to SEQRA;

Now, therefore, it is hereby

DETERMINED, that it is in the public interest to increase and improve the facilities of the District as hereinabove described, at the estimated maximum cost of \$700,000; and it is hereby

ORDERED, that the facilities of the District shall be so increased and improved

and that a careful estimate of the cost of the improvement shall be made and a proposed contract for the improvement shall be prepared and presented to the Town Board as soon as possible; and it is hereby

FURTHER ORDERED, that the expense of said increase and improvement of facilities shall be financed by the issuance of \$700,000 bonds of the Town, and the costs of said increase and improvement of facilities, including payment of principal of and interest on said bonds, shall be paid by the assessment, levy and collection of assessments upon the several lots and parcels of land within the District which the Town Board shall deem especially benefited by said facilities, so much upon and from each as shall be in just proportion to the amount of benefit which the improvement shall confer upon the same; and it is hereby

FURTHER ORDERED, that the Town Clerk record, or cause to be recorded, a certified copy of this Resolution and Order After Public Hearing in the office of the Clerk of Erie County within ten (10) days after adoption thereof.

DATED: March 17, 2014

(SEAL)

TOWN BOARD OF THE TOWN OF CHEEKTOWAGA

The adoption of the foregoing Resolution and Order was duly put to a vote on roll call, which resulted as follows:

Supervisor Mary F. Holtz	Voting <u>AYE</u>
Councilmember James P. Rogowski	Voting <u>AYE</u>
Councilmember Charles C. Markel	Voting <u>AYE</u>
Councilmember Gerald P. Kaminski, Sr.	Voting <u>AYE</u>
Councilmember Angela M. Wozniak	Voting <u>AYE</u>
Councilmember Diane Benczkowski	Voting <u>AYE</u>
Councilmember Timothy J. Meyers	Voting <u>AYE</u>

The Resolution and Order were declared adopted.

RESULT:	ADOPTED [UNANIMOUS]
MOVER:	Mary Holtz, Supervisor
SECONDER:	Gerald Kaminski, Councilmember
AYES:	Holtz, Rogowski, Markel, Kaminski, Wozniak, Benczkowski, Meyers



4. RESOLUTION 2014-162

Bond Resolution Approving District Improvements - Replacement of Sanitary Sewers

Sponsored By: Supervisor Holtz, Councilmember Kaminski

BOND RESOLUTION OF THE TOWN OF CHEEKTOWAGA,
NEW YORK, ADOPTED MARCH 17, 2014, APPROPRIATING
\$700,000 FOR THE INCREASE AND IMPROVEMENT OF
FACILITIES OF THE CONSOLIDATED SEWER DISTRICT, AND
AUTHORIZING THE ISSUANCE OF \$700,000 SERIAL BONDS
OF SAID TOWN TO FINANCE SAID APPROPRIATION

Offered by: Supervisor Mary F. Holtz

Seconded By: Councilmember Gerald Kaminski

Recital

WHEREAS, following a public hearing duly called and held, the Town Board of the Town of Cheektowaga, in the County of Erie, New York (the "Town") has determined that it is in the public interest to increase and improve the facilities of the Consolidated Sewer District (the "District"), and ordered that such facilities be so increased and improved;

Now, therefore, be it

RESOLVED BY THE TOWN BOARD OF THE TOWN OF CHEEKTOWAGA, IN THE COUNTY OF ERIE, NEW YORK (by the favorable vote of not less than two-thirds of all the members of said Board) AS FOLLOWS:

Section 1. The Town hereby appropriates the amount of \$700,000 for the increase and improvement of facilities of the District, consisting of the replacement of various sanitary sewers. The estimated maximum cost thereof, including preliminary costs and costs incidental thereto and the financing thereof, is \$700,000. The plan of financing includes the

issuance of \$700,000 bonds of the Town to finance said appropriation and the assessment, levy and collection of assessments upon the several lots and parcels of land within the District which the Town Board shall deem especially benefited by said facilities, so much upon and from each as shall be in just proportion to the amount of benefit which the improvement shall confer upon the same.

Section 2. Bonds of the Town are hereby authorized to be issued in the principal amount of \$700,000 pursuant to the provisions of the Local Finance Law, constituting Chapter 33-a of the Consolidated Laws of the State of New York (herein called the "Law"), to finance said appropriation.

Section 3. The following additional matters are hereby determined and stated:

(a) The period of probable usefulness of the object or purpose for which said bonds are authorized to be issued, within the limitations of Section 11.00 a. 4 of the Law, is forty (40) years.

(b) The proceeds of the bonds herein authorized and any bond anticipation notes issued in anticipation of said bonds may be applied to reimburse the Town for expenditures made after the effective date of this resolution, or for expenditures made on or before the effective date of this resolution if a prior declaration of intent to issue bonds has been made. The foregoing statement of intent with respect to reimbursement is made in conformity with Treasury Regulation Section 1.150-2 of the United States Treasury Department.

(c) The proposed maturity of the serial bonds authorized by this resolution will exceed five (5) years.

Section 4. Each of the bonds authorized by this resolution and any bond anticipation notes issued in anticipation of said bonds shall contain the recital of validity prescribed by Section 52.00 of the Law and said bonds and any notes issued in anticipation of said bonds shall be general obligations of the Town, payable as to both principal and interest by a general tax upon all the taxable real property within the Town without limitation as to rate or amount. The faith and credit of the Town are hereby irrevocably pledged to the punctual

payment of the principal of and interest on said bonds and any notes issued in anticipation of the sale of said bonds, and provision shall be made annually in the budget of the Town by appropriation for (a) the amortization and redemption of the bonds and any notes issued in anticipation thereof to mature in such year and (b) the payment of interest to be due and payable in such year.

Section 5. Subject to the provisions of this resolution and of the Law and pursuant to the provisions of Section 21.00 relative to the authorization of the issuance of bonds with substantially level or declining annual debt service, Section 30.00 relative to the authorization of the issuance of bond anticipation notes and Section 50.00 and Sections 56.00 to 60.00 and 168.00 of the Law, the powers and duties of the Town Board relative to authorizing bond anticipation notes and prescribing the terms, form and contents and as to the sale and issuance of the bonds herein authorized, and the renewals of said bond anticipation notes, and relative to executing contracts for credit enhancements and providing for substantially level or declining annual debt service, are hereby delegated to the Supervisor, the chief fiscal officer of the Town.

Section 6. The validity of the bonds authorized by this resolution, and of any notes issued in anticipation of said bonds, may be contested only if:

- (a) such obligations are authorized for an object or purpose for which the Town is not authorized to expend money, or
- (b) the provisions of law which should be complied with at the date of the publication of such resolution, or a summary thereof, are not substantially complied with, and

an action, suit or proceeding contesting such validity is commenced within twenty days after the date of such publication, or

- (c) such obligations are authorized in violation of the provisions of the constitution.

Section 7. This resolution shall take effect immediately and the Town Clerk is hereby authorized and directed to publish the foregoing bond resolution, in summary, in the "CHEEKTOWAGA BEE," a newspaper having a general circulation in said Town, which

newspaper is hereby designated as the official newspaper of the Town for such publication, together with the Town Clerk's statutory notice in the form prescribed by Section 81.00 of the Local Finance Law of the State of New York.

The adoption of the foregoing Resolution was duly put to a vote on roll call, which resulted as follows:

Supervisor Mary F. Holtz	Voting	<u> AYE </u>
Councilmember James P. Rogowski	Voting	<u> AYE </u>
Councilmember Charles C. Markel	Voting	<u> AYE </u>
Councilmember Gerald P. Kaminski, Sr.	Voting	<u> AYE </u>
Councilmember Angela M. Wozniak	Voting	<u> AYE </u>
Councilmember Diane Benczkowski	Voting	<u> AYE </u>
Councilmember Timothy J. Meyers	Voting	<u> AYE </u>

The Resolution was declared adopted.

RESULT:	ADOPTED [UNANIMOUS]
MOVER:	Mary Holtz, Supervisor
SECONDER:	Gerald Kaminski, Councilmember
AYES:	Holtz, Rogowski, Markel, Kaminski, Wozniak, Benczkowski, Meyers



5. RESOLUTION 2014-163

Award of Bid for Demolition and Asbestos Abatement of 19 Euclid Avenue (BID 2014-10 LAW)

Sponsored By: Councilmember Markel, Supervisor Holtz

WHEREAS, a Notice to Bidders was advertised for the Demolition and Asbestos Abatement of structures at 19 Euclid Avenue (BID 2014-10 LAW); and

WHEREAS, bid proposals were received and opened on March 5, 2014 for said demolition and asbestos abatement; and

WHEREAS, the proposals were reviewed by the Town Attorney and, based on proposals submitted, the Town Attorney has recommended that this Town Board award the bid for the demolition and asbestos abatement of the structures at 19 Euclid Avenue to United Demolition & Excavating, LLC; NOW, THEREFORE, BE IT

RESOLVED, that this Town Board hereby awards the bid for the demolition and asbestos abatement of structures located at 19 Euclid Avenue to:

United Demolition & Excavating, LLC
10187 Main Street
Clarence, New York 14031

for the bid price of \$25,975.00, being the lowest responsible bid meeting specifications; and BE IT FURTHER

RESOLVED, that the Supervisor be and hereby is directed to execute an agreement with United Demolition & Excavating, LLC, for the aforesaid services, and BE IT FURTHER

RESOLVED, that moneys for said services shall be appropriated from budget line item number 0800-800-0440.

RESULT:	ADOPTED [UNANIMOUS]
MOVER:	Charles Markel, Councilmember
SECONDER:	Mary Holtz, Supervisor
AYES:	Holtz, Rogowski, Markel, Kaminski, Wozniak, Benczkowski, Meyers



6. RESOLUTION 2014-164

Settlement of Claim

Sponsored By: Councilmember Markel, Councilmember Kaminski

WHEREAS, under Chapter 66 of the Code of the Town of Cheektowaga, every owner of any area, lot or parcel shall cut, trim or otherwise remove or cause to be cut, trimmed or otherwise removed all grass, weeds, brush or plant growth in excess of six inches, and

WHEREAS, in the event the owner of property, after proper notification by the Town, does not cut the grass, etc. on its property, the Town can have the grass cut and assess the cost against the property, and

WHEREAS, in June and August of 2013, the Town retained Gardenville Landscape & Nursery, Inc. to cut the grass and remove debris from property located at 3161 Broadway in the Town, and

WHEREAS, the owner of 3161 Broadway passed away in 2008 and the executor of her estate has been attempting to sell the property, and

WHEREAS, a sale is now pending; however the attorney for the executor of the estate of the owner claims it was not timely notified of the grass cutting, etc. by the Town; feels that the charges incurred by the Town are excessive, and alleges that this potential lien will interfere with the sale of the property; the attorney has indicated that, if these charges are not removed from the property, he will have no recourse but to initiate legal proceedings against the Town to remove the charges and to compel the Town to pay for expenses relating to the loss of the sale of the property, and

WHEREAS, the Director of the Office of Community Development and Neighborhood Preservation has indicated that she is willing to waive these charges in exchange for a commitment from the owner that he will not pursue any legal action against the Town, NOW, THEREFORE, BE IT

RESOLVED, that this Town Board hereby agrees to settle this threatened litigation matter by removing the aforementioned charges being assessed against 3161 Broadway by the Office of Community Development and Neighborhood Preservation, and BE IT FURTHER

RESOLVED, that the Supervisor be and hereby is authorized and directed to execute any and all documents necessary to effectuate this settlement.

RESULT:	ADOPTED [UNANIMOUS]
MOVER:	Charles Markel, Councilmember
SECONDER:	Gerald Kaminski, Councilmember
AYES:	Holtz, Rogowski, Markel, Kaminski, Wozniak, Benczkowski, Meyers



7. RESOLUTION 2014-165

Call for Public Hearing - 432 Dingens Street Rezoning Request

Sponsored By: Councilmember Markel, Councilmember Rogowski

WHEREAS, Sunoco , Inc. R&M has made application and requested the rezoning of 432 Dingens Street from C-Retail Business to MS-Motor Services for the re-development of an existing gas station /convenience store at 432 Dingens Street, NOW, THEREFORE BE IT

RESOLVED, that a Public Hearing be held regarding said request under the provisions of the Zoning Law on April 7, 2014 at 6:45 P.M., at the Cheektowaga Town Hall, 3301 Broadway at the corner of Union Road.



Notice of Public Hearing

NOTICE IS HEREBY GIVEN that a Public Hearing will be held by the Town Board of the Town of Cheektowaga, Erie County, New York at the Town Hall in the said Town of Cheektowaga, 3301 Broadway corner of Union Road on the 7th day of April, 2014 at 6:45 o'clock P.M., of said day for the purpose of considering the application of:

Sunoco, Inc. R&M

For the rezoning of 432 Dingens Street from from C-Retail Business to MS-Motor Services for the re-development of an existing gas station /convenience store at 432 Dingens Street.

All parties in interest and citizens will be given an opportunity to be heard in regard to such proposed application.

BY ORDER OF THE TOWN BOARD, Town of Cheektowaga, NY

Alice Magierski, TOWN CLERK



All that tract or parcel of land situate in Town of Cheektowaga, County of Erie, and State of New York, being known as Subdivision Lots 3 and 4 as shown on a map entitled "Shanley Street Extension Subdivision Plat", part of Farm Lots 147 and 148, Township 10 and Range 7, Holland Land Company, filed in the Erie County Clerk's Office on October 9, 1952 under Map cover 1791, and being more particularly bounded and described as follows:

Beginning at the point of intersection of the westerly line of Shanley Street (60 feet wide) and the northerly line of Dingens Street (73.5 feet wide); thence, North 81°13'45" West, on the northerly line of said Dingens Street, a distance of 118.43 feet to a rebar found on the division line between the City of Buffalo on the west and the Town of Cheektowaga on the east; thence, North 08°25'50" East, on said division line, a distance of 118.61 feet to a point; thence, South 81°30'00" East, a distance of 118.57 feet to a point of the westerly line of said

Shanley Street; thence, South 08°30'00" West, on the westerly line of said Shanley Street, a distance of 119.17 feet to the Point of Beginning. Said parcel containing 0.323 acres, more or less, described as Parcel A as filed in Book 9519 of Deeds, Page 551 in the Erie County Clerk's Office, and as shown on a map prepared by Bergmann Associates entitled "Property Map Sunoco, Inc., 422, 424, 428 & 432 Dingens Street", drawing number CM-1, dated August 26, 2013, last revised on September 30, 2013, said map to be filed in the Erie County Clerk's Office.

RESULT:	ADOPTED [UNANIMOUS]
MOVER:	Charles Markel, Councilmember
SECONDER:	James P. Rogowski, Councilmember
AYES:	Holtz, Rogowski, Markel, Kaminski, Wozniak, Benczkowski, Meyers



8. RESOLUTION 2014-166

Notice to Bidders - Cold Milling of Various Town Highways (Bid #2014-12)

Sponsored By: Councilmember Kaminski, Supervisor Holtz

WHEREAS, it is in order that bids be advertised for the Cold Milling of Various Town Highways in the Town of Cheektowaga for the calendar year 2014 (Bid 2014-12), AND

WHEREAS, the Cheektowaga Engineering Department is hereby requested to prepare specifications, NOW, THEREFORE, BE IT

RESOLVED, that this request be granted and that the Town Clerk be directed to publish a Notice to Bidders in connection with the Cold Milling of Various Town Highways, said notice to be published in the CHEEKTOWAGA BEE, AND, BE IT FURTHER

RESOLVED, that sealed bids will be received on the 2nd day of April, 2014 at 11:00 am at a public bid opening to be held in the Council Chambers at the Cheektowaga Town Hall.



NOTICE TO BIDDERS

Sealed proposals will be received and considered by the Town Board of the Town of Cheektowaga on April 2, 2014 at 11:00 A.M., at the Town Hall, corner of Broadway and Union Roads, Cheektowaga, New York, for the Cold Milling of Various Town Highways in the Town of Cheektowaga for the calendar year 2014 (Bid 2014-12).

Information for bidders and specifications may be obtained from the Town Clerk at her office in said Town.

Proposals shall be submitted in a sealed envelope, plainly marked on the outside "Bid for Cold Milling of Various Town Highways" and submitted to the Town Clerk prior to bid opening.

No bidder may withdraw his bid within forty-five (45) days after the actual date of the opening thereof.

The Town Board reserves the right to consider informal any bid not prepared and submitted in accordance with the provisions of the specifications and contract documents, and may waive any informalities, make an award to other than the low bidder, should it be in the best interest of the Town, or reject any and all bids.

By order of the Town Board of the Town of Cheektowaga, Erie County, New York.

Alice Magierski, Town Clerk

DATED: March 17, 2014

RESULT:	ADOPTED [UNANIMOUS]
MOVER:	Gerald Kaminski, Councilmember
SECONDER:	Mary Holtz, Supervisor
AYES:	Holtz, Rogowski, Markel, Kaminski, Wozniak, Benczkowski, Meyers



9. RESOLUTION 2014-167

Notice to Bidders - Manhole/Catch Basin Frames & Covers (Bid #2014-13)

Sponsored By: Councilmember Kaminski, Supervisor Holtz

WHEREAS, it is in order that bids be advertised for the purchase of Manhole/Catch Basin Frames and Covers for the year of 2014 (Bid 2014-13) for the Town of Cheektowaga, AND

WHEREAS, the Engineering Department has prepared specifications for same, NOW, THEREFORE, BE IT

RESOLVED, that the Town Clerk be directed to publish a Notice to Bidders for the furnishing of Manhole/Catch Basin Frames and Covers for the year of 2014, said notice to be published in the CHEEKTOWAGA BEE, AND, BE IT FURTHER

RESOLVED, that sealed bids will be received on the 2nd day of April, 2014 at 11:00 A.M., at a public bid opening to be held in the Council Chambers in the Cheektowaga Town Hall.



NOTICE TO BIDDERS

Sealed proposals will be received and considered by the Town Board of the Town of Cheektowaga on April 2, 2014 at 11:00 A.M., at the Town Hall, corner of Broadway and Union Roads, Cheektowaga, New York, for the furnishing of Manhole/Catch Basin Frames and Covers for the Sewer Maintenance and Highway Departments for the 2014 calendar year (Bid 2014-13).

Information for bidders and specifications may be obtained from the Town Clerk at her office in said Town.

Proposals shall be submitted in a sealed envelope, plainly marked on the outside "Bid for Furnishing Manhole/Catch Basin Frames and Covers" and submitted to the Town Clerk prior to bid opening.

No bidder may withdraw his bid within forty-five (45) days after the actual date of the opening thereof.

The Town Board reserves the right to consider informal any bid not prepared and submitted in accordance with the provisions of the specifications and contract documents, and may waive any informalities, make an award to other than the low bidder, should it be in the best interest of the Town, or reject any and all bids.

By order of the Town Board of the Town of Cheektowaga, Erie County, New York.

Alice Magierski, Town Clerk

DATED: March 17, 2014

RESULT:	ADOPTED [UNANIMOUS]
MOVER:	Gerald Kaminski, Councilmember
SECONDER:	Mary Holtz, Supervisor
AYES:	Holtz, Rogowski, Markel, Kaminski, Wozniak, Benczkowski, Meyers



10. RESOLUTION 2014-168

Notice to Bidders For Asbestos Survey for Property Located At 42 Avery Place (BID 2014-14 LAW)

Sponsored By: Councilmember Markel, Supervisor Holtz

WHEREAS, pursuant to the Town's Unsafe Buildings Law, Nussbaumer & Clarke, Inc., a duly authorized agent of the Town of Cheektowaga, has issued a written report stating that the structure(s) located at 42 Avery Place is unsafe and recommended that such structure(s) be demolished; and

WHEREAS, the owners and/or lienholders of said property were notified to demolish said structure(s) on said property, and no action for demolition has been taken to date; and

WHEREAS, a hearing was held in front of this Board on February 19, 2014 concerning said unsafe structure(s) and the requested demolition; and

WHEREAS, the Town of Cheektowaga needs to take action to demolish the building located on said property in the event the owner of same does not do so; and

WHEREAS, prior to demolition of said property, the Town needs to have an asbestos survey done to determine whether there is asbestos in said structure(s); and

WHEREAS, a Notice to Bidders has been prepared for this matter; NOW, THEREFORE, BE IT

RESOLVED, that this Town Board hereby approves the Notice to Bidders for the Asbestos Survey for property located at 42 Avery Place in the Town of Cheektowaga (Bid 2014-14 LAW); and BE IT FURTHER

RESOLVED, that the Town Clerk's Office be and hereby is directed to publish the attached Notice to Bidders in the CHEEKTOWAGA BEE; and BE IT FURTHER

RESOLVED, that bids for the Asbestos Survey, Specifications and Air Monitoring Services for 42 Avery Place shall be due no later than Wednesday, April 2, 2014 at 11:00 A.M. at the Town Clerk's Office, and BE IT FURTHER

RESOLVED, that the Town Clerk be and hereby is appointed as the officer to open said bids in the Council Chambers of Town Hall on Wednesday, April 2, 2014 at 11:00 a.m.



NOTICE TO BIDDERS

Sealed proposals will be received by the Town of Cheektowaga on Wednesday, April 2, 2014 at 11:00 A.M. at the Town Hall, 3301 Broadway, Cheektowaga, New York, for asbestos surveys, asbestos specifications preparation, and air monitoring services for residential property located at 42 Avery Place, Cheektowaga, New York (BID 2014-14 LAW).

Information for bidders and specifications may be obtained from the Town Clerk at her office in said Town.

The Town Board reserves the right to consider informal any bid not prepared and submitted in accordance with the provisions of the specification and contract documents, and may waive any informalities, make an award to other than the low bidder, or reject any or all bids should it be in the best interest of the Town.

BY ORDER OF THE TOWN BOARD OF THE TOWN OF CHEEKTOWAGA, ERIE COUNTY, NEW YORK.

Alice Magierski, Town Clerk

Dated: 17 March 2014

RESULT:	ADOPTED [UNANIMOUS]
MOVER:	Charles Markel, Councilmember
SECONDER:	Mary Holtz, Supervisor
AYES:	Holtz, Rogowski, Markel, Kaminski, Wozniak, Benczkowski, Meyers



11. RESOLUTION 2014-169

Authorize Supervisor to Execute Agreement with USDA for Geese Control

Sponsored By: Councilmember Rogowski, Councilmember Wozniak

WHEREAS, the Town of Cheektowaga is experiencing a problem with Canadian Geese in Stiglmeier Park and other areas in the Town, AND

WHEREAS, the U.S. Department of Agriculture, Wildlife Services Division ("USDA"), administers a Canada Goose Management Program in certain areas of the United States; in the State of New York, the USDA works in coordination with the New York State Department of Environmental Conservation, AND

WHEREAS, prior to implementation of this program, the USDA, pursuant to the National Environmental Policy Act ("NEPA"), prepared an environmental assessment and issued a Decision of Finding of No Significant Impact, AND

WHEREAS, the Town of Cheektowaga Facilities Department submitted an application for funding and authorization of a Canada Goose Management Program administered by the USDA on lands owned and/or controlled by the Town of Cheektowaga, and on private lands with landowner permission for 2014, AND

WHEREAS, the Town Environmental Advisory Committee previously reviewed this application and its impact on the Town and recommended that a determination of non-significance be issued for this program, and this Town Board rendered a Determination of Non Significance for same, AND

WHEREAS, the USDA requires that anyone wishing to have the USDA implement this program on their behalf execute an agreement with the USDA and commit to remit payment to the USDA for this program, AND

WHEREAS, the cost of the program proposed for the Town of Cheektowaga is approximately \$5,270.00, AND

WHEREAS, this Board wishes to proceed with utilizing the services of the USDA to operate the Canada Goose Management Program for the Town of Cheektowaga in 2014, NOW, THEREFORE, BE IT

RESOLVED, that, subject to review and approval by the Town Attorney's Office, the Supervisor be and hereby is authorized and directed to execute an agreement with the USDA and all other documents necessary to authorize the USDA to administer its Canada Goose Management Program for the Town of Cheektowaga, and BE IT FURTHER

RESOLVED, that moneys not to exceed \$5,270.00 for this program, shall be appropriated from budget line item number 100-7110-4106.

RESULT: **ADOPTED [UNANIMOUS]**
MOVER: James P. Rogowski, Councilmember
SECONDER: Angela M. Wozniak, Councilmember
AYES: Holtz, Rogowski, Markel, Kaminski, Wozniak, Benczkowski, Meyers



12. RESOLUTION 2014-170

Authorize Supervisor to Execute NYSDOT Right-of-Way Clearance Certificate

Sponsored By: Supervisor Holtz, Councilmember Meyers

WHEREAS, by Resolution dated January 6, 2014 (Resolution 2014-45), the Town Supervisor was authorized and directed to execute a contract of sale for the acquisition of a .02 acre parcel and a .04 acre permanent easement required to facilitate the Rein Road Bridge Rehabilitation Project, PIN 5758.38; and

WHEREAS, the necessary right-of-way and easement access rights have been acquired, payment completed, and associated documents have been filed in the Erie County Clerk's Office; NOW, THEREFORE, BE IT

RESOLVED, that the Supervisor be and hereby is authorized and directed to execute the "Right-of-Way Clearance Certificate" for the Rein Road Bridge Rehabilitation Project for submission to the NYSDOT Region 5 Real Estate Officer.

RESULT:	ADOPTED [UNANIMOUS]
MOVER:	Mary Holtz, Supervisor
SECONDER:	Timothy J. Meyers, Councilmember
AYES:	Holtz, Rogowski, Markel, Kaminski, Wozniak, Benczkowski, Meyers



13. RESOLUTION 2014-171

Approve Cultural Group Funding for Various Cultural Groups

Sponsored By: Councilmember Wozniak, Councilmember Markel

WHEREAS, the Town, in its 2014 budget, allocated moneys to certain cultural and not-for-profit organizations which are involved in activities which benefit the Town, and

WHEREAS, agreement(s) between the Town and these cultural and not-for-profit organizations have been prepared and forwarded to such groups, and

WHEREAS, the organization(s) listed below have completed and returned signed agreement(s) and their accounting report(s) from the 2013 funding to the Town, NOW, THEREFORE, BE IT

RESOLVED that this Town Board hereby approves agreement(s) with the cultural and not-for-profit organization(s) listed below for the amount(s) listed, and BE IT FURTHER

RESOLVED that the Supervisor be and hereby is authorized and directed to execute agreement(s) with the following referenced cultural and not-for-profit organization(s) for the following respective amount(s):

<u>Cultural/Not-For-Profit Organization</u>	<u>Funding Approved</u>
Cheektowaga Community Symphony Orchestra	\$18,000.00
Friends of the Woods, Ltd.	\$800.00
Cheektowaga Community Chorus, Inc.	\$12,000.00

And BE IT FURTHER

RESOLVED that the aforementioned moneys shall be paid to the respective cultural/not-for-profit organization(s) out of the respective cultural group budget line item(s) in the 2014 Town budget, subject to audit and approval of a properly signed Town voucher.

RESULT:	ADOPTED [UNANIMOUS]
MOVER:	Angela M. Wozniak, Councilmember
SECONDER:	Charles Markel, Councilmember
AYES:	Holtz, Rogowski, Markel, Kaminski, Wozniak, Benczkowski, Meyers



14. RESOLUTION 2014-172

Approve Purchase of Two (2) New and Unused 2014 Caterpillar 938K Wheel Loaders

Sponsored By: Councilmember Kaminski, Supervisor Holtz

WHEREAS, the Town Board authorized the purchase of two (2) new and unused 2013 Caterpillar 938K Wheel Loaders from Milton Cat, 4610 East Saile Drive, Batavia, New York 14020, as specified under New York State OSG Contract PC 65318 at a regular board meeting on December 17, 2012 AND

WHEREAS, said New York State OSG Contract PC 65318 runs through October 31, 2015, AND

WHEREAS, Milton Cat offers a one year trade in program for said equipment as long as the New York State OSG Contract remains in effect, AND

WHEREAS, said trade in program is based on the hours of use of equipment and any price increase in the New York State OSG Contract, AND

WHEREAS, the Highway Department has requested authorization to Trade-in two (2) 2013 Milton Cat 938K Caterpillar Wheel Loaders for two (2) new and unused 2014 Caterpillar 938K wheel loaders as specified under the terms of the Milton Cat's trade in program and New York State OSG Contract PC 65318, AND

WHEREAS, funds for said purchase have been budgeted and are available under account number 300-5130-2407, NOW THEREFORE BE IT,

RESOLVED, that the Town Board hereby authorized to trade-in two (2) 2013 Milton Cat 938K Caterpillar Wheel Loaders for two (2) new and unused 2014 Caterpillar 938K Wheel Loaders in the amount of \$22,862.00 from:

Milton Cat
4610 East Saile Drive
Batavia, New York 14020

RESULT:	ADOPTED [UNANIMOUS]
MOVER:	Gerald Kaminski, Councilmember
SECONDER:	Mary Holtz, Supervisor
AYES:	Holtz, Rogowski, Markel, Kaminski, Wozniak, Benczkowski, Meyers



15. RESOLUTION 2014-173

Opposition to Closing of Amherst Social Security Office

Sponsored By: Holtz, Rogowski, Markel, Kaminski, Wozniak, Benczkowski, Meyers

WHEREAS, the Social Security Administration is planning on closing their Amherst office; and

WHEREAS, this Social Security Office services approximately 269 square miles of northern Erie County, including portions of Cheektowaga; and

WHEREAS, the Amherst office covers a population of 384,515 according to the 2010 census and is expected to grow to 387,815 by 2018; and

WHEREAS, approximately 16.77% of the served population is age 65 and over as of 2013, and 18.74% of the served population is projected to be over 65 by 2018; and

WHEREAS, included in the Amherst office's service area are 17 of the 36 nursing homes in Erie County; and

WHEREAS, People, Inc., a not-for-profit agency serving families and people with disabilities, as well as assisting seniors to live more healthy, independent and productive lives, opened an office in the same building as the Amherst Social Security Office so that the 200 employees could work closer with the 22 employees of the Amherst Office to help manage the cases of some 900 individuals receiving assistance, some of whom include residents of Cheektowaga; and

WHEREAS, the next nearest offices are in the City of Buffalo (9.1 miles away) and West Seneca (14 Miles away); and

WHEREAS, the elderly, poor and disabled who rely on Social Security Retirement Income and Disability Benefits who most need access to the office are the least likely able to utilize the internet or be able to travel to the next nearest office should this office be closed;
NOW, THEREFORE, BE IT

RESOLVED, that the Town of Cheektowaga opposes the closing of the Amherst office of the Security Administration and supports the Social Security Administration Accountability Act which would require the Social Security Administration to halt field office closings until they can report on caseload data, service population, and staffing levels at the field offices along with the process by which the offices were selected for closing; and BE IT FURTHER

RESOLVED, that this Town Board directs the Town Clerk to forward this Resolution to Rep. Brian M. Higgins, Sen. Charles E. Schumer, Sen. Kirsten E. Gillibrand, Erie County Legislators Patrick B. Burke and Ted B. Morton, as well as to the Town/Village Boards of Amherst, Clarence, Grand Island, Lancaster, Newstead, Tonawanda, Kenmore, and Williamsville.

RESULT:	ADOPTED [UNANIMOUS]
MOVER:	Mary Holtz, Supervisor
SECONDER:	James P. Rogowski, Councilmember
AYES:	Holtz, Rogowski, Markel, Kaminski, Wozniak, Benczkowski, Meyers



16. RESOLUTION 2014-174

Salary of Clerk to Town Justice (Non-Union)

Sponsored By: Councilmember Kaminski, Councilmember Benczkowski

BE IT RESOLVED, that the Clerk to Town Justice (Non-Union) be and hereby is to receive the annual salary of \$47,980 effective March 18, 2014.

RESULT:	ADOPTED [UNANIMOUS]
MOVER:	Gerald Kaminski, Councilmember
SECONDER:	Diane Benczkowski, Councilmember
AYES:	Holtz, Rogowski, Markel, Kaminski, Wozniak, Benczkowski, Meyers



17. RESOLUTION 2014-175

Establish Salaries for Zoning Board Officials

Sponsored By: Councilmember Benczkowski, Councilmember Markel

WHEREAS, salaries were previously established for the Chairman and Members of the Town of Cheektowaga Zoning Board of Appeals, and

WHEREAS, due to the fact that the Town no longer retains a court reporter to take the minutes of the Zoning Board of Appeals meetings, one of the members now has the added responsibility as Secretary to prepare the minutes, and

WHEREAS, the salary for the Member designated as Secretary needs to be established, NOW, THEREFORE, BE IT

RESOLVED, that the salaries for the Chairman, three (3) Members and the Member assigned as Secretary shall be as follows, effective immediately:

Zoning Board of Chairman	\$5,574.00
Zoning Board Member Designated as Secretary	\$5,043.00
Other Zoning Board Members (3)	\$4,115.00

RESULT:	ADOPTED [UNANIMOUS]
MOVER:	Diane Benczkowski, Councilmember
SECONDER:	Charles Markel, Councilmember
AYES:	Holtz, Rogowski, Markel, Kaminski, Wozniak, Benczkowski, Meyers



18. RESOLUTION 2014-176

Hiring/Termination of Part-Time/Seasonal Employees

Sponsored By: Councilmember Kaminski, Supervisor Holtz

BE IT RESOLVED, that the following individual be and hereby is hired as a **PART-TIME EMPLOYEE** in the department listed, not to exceed nineteen (19) hours on a weekly basis, in compliance with Civil Service Laws and Regulations as well as the provisions of the Town's collective bargaining agreement between the Town of Cheektowaga and the Town of Cheektowaga Employees Association:

POLICE DEPARTMENT Student Assistant \$8.00/hour effective 3/18/14
Katherine E. Lipczynski, Cheektowaga, New York

BE IT RESOLVED, that the following be and hereby are amended as follows:

POLICE DEPARTMENT Police Attendant \$15.00/hour effective 3/14/14
Melanie A. Dingeldey, Sloan, New York

CENTRAL RECORDS from Senior Clerk Typist (Grant) to Clerk (Part Time) \$9.00/hour effective 4/1/14
Carol Brunner, Cheektowaga, New York

BE IT RESOLVED, that the following employee be transferred as follows:

CENTRAL RECORDS to JUSTICE COURT Clerk \$9.25/hour effective 3/18/14
Kaitlyn M. Gallagher, Cheektowaga, New York

Motion by Councilmember Rogowski; Seconded by Councilmember Markel to waive the reading of names for this resolution. Motion Carried.

RESULT:	ADOPTED [UNANIMOUS]
MOVER:	Gerald Kaminski, Councilmember
SECONDER:	Mary Holtz, Supervisor
AYES:	Holtz, Rogowski, Markel, Kaminski, Wozniak, Benczkowski, Meyers



19. RESOLUTION 2014-177

Appointment of Laborer (Temporary)/Sewer Maintenance/Joseph G. Rohloff

Sponsored By: Councilmember Kaminski, Supervisor Holtz

WHEREAS, a temporary vacancy exists in the title of Laborer in Sewer Maintenance;
AND

WHEREAS, Joseph G. Rohloff applied for said vacancy and meets the necessary qualifications for appointment; NOW, THEREFORE, BE IT

RESOLVED, that Joseph G. Rohloff of Cheektowaga, New York, be and hereby is appointed to the temporary position of Laborer in Sewer Maintenance in accordance with the terms and conditions of the Town's collective bargaining agreement with the Town of Cheektowaga Employees Association effective March 18, 2014.

RESULT:	ADOPTED [UNANIMOUS]
MOVER:	Gerald Kaminski, Councilmember
SECONDER:	Mary Holtz, Supervisor
AYES:	Holtz, Rogowski, Markel, Kaminski, Wozniak, Benczkowski, Meyers



20. RESOLUTION 2014-178

Travel Authorization Police Department/International Association of Auto Theft Investigators/Detective Mark Jedd

Sponsored By: Councilmember Kaminski, Councilmember Benczkowski

WHEREAS, the International Association of Auto Theft Investigators Conference is being held May 12 through May 15, 2014 in Cleveland, Ohio; AND

WHEREAS, Detective Mark Jedd has been recommended to attend said conference; AND

WHEREAS, Police Chief David Zack has submitted a request for travel authorization along with the proper paperwork in a timely manner; AND

WHEREAS, the total cost to the Town shall not exceed \$716; AND

WHEREAS, these expenses have been budgeted by the Department; NOW, THEREFORE, BE IT

RESOLVED, that Detective Mark Jedd be and hereby is authorized to attend the International Association of Auto Theft Investigators Conference being held May 12 through May 15, 2014 in Cleveland, Ohio.

RESULT:	ADOPTED [UNANIMOUS]
MOVER:	Gerald Kaminski, Councilmember
SECONDER:	Diane Benczkowski, Councilmember
AYES:	Holtz, Rogowski, Markel, Kaminski, Wozniak, Benczkowski, Meyers



21. RESOLUTION 2014-179

Travel Authorization Police Department/Background Investigations for Police Applicants/Police Officers Anthony Nazzarett and Michael Curtis

Sponsored By: Councilmember Kaminski, Councilmember Benczkowski

WHEREAS, the Background Investigations for Police Applicants Course is being held April 3 through April 4, 2014 in Cleveland, Ohio; AND

WHEREAS, Police Officers Anthony Nazzarett and Michael Curtis have been recommended to attend said course; AND

WHEREAS, Police Chief David Zack has submitted a request for travel authorization along with the proper paperwork in a timely manner; AND

WHEREAS, the total cost to the Town shall not exceed \$1,012; AND

WHEREAS, these expenses have been budgeted by the Department; NOW, THEREFORE, BE IT

RESOLVED, that Police Officers Anthony Nazzarett and Michael Curtis be and hereby are authorized to attend the Background Investigations for Police Applicants Course being held April 3 through April 4, 2014 in Cleveland, Ohio.

RESULT:	ADOPTED [UNANIMOUS]
MOVER:	Gerald Kaminski, Councilmember
SECONDER:	Diane Benczkowski, Councilmember
AYES:	Holtz, Rogowski, Markel, Kaminski, Wozniak, Benczkowski, Meyers



22. RESOLUTION 2014-180

Travel Authorization Police Department/New York Tactical Officers Association Expo and Conference/Lieutenant Thomas Gerace, Detective Kevin Schmitt, Police Officers David Vogel, Justin Haag, Darryl Leszkowicz and Shawn McAdams

Sponsored By: Councilmember Kaminski, Councilmember Benczkowski

WHEREAS, the New York Tactical Officers Association and Expo Conference is being held April 29 through May 1, 2014 in Verona, New York; AND

WHEREAS, Lieutenant Thomas Gerace, Detective Kevin Schmitt, Police Officers David Vogel, Justin Haag, Darryl Leszkowicz and Shawn McAdams have been recommended to attend said conference; AND

WHEREAS, Police Chief David Zack has submitted a request for travel authorization along with the proper paperwork in a timely manner; AND

WHEREAS, the total cost to the Town shall not exceed \$ 2,932; AND

WHEREAS, these expenses have been budgeted by the Department; NOW, THEREFORE, BE IT

RESOLVED, that Lieutenant Thomas Gerace, Detective Kevin Schmitt, Police Officers David Vogel, Justin Haag, Darryl Leszkowicz and Shawn McAdams be and hereby are authorized to attend the New York Tactical Officers Association and Expo Conference being held April 29 through May 1, 2014 in Verona, New York.

RESULT:	ADOPTED [UNANIMOUS]
MOVER:	Gerald Kaminski, Councilmember
SECONDER:	Diane Benczkowski, Councilmember
AYES:	Holtz, Rogowski, Markel, Kaminski, Wozniak, Benczkowski, Meyers



23. RESOLUTION 2014-181

Travel Authorization Accounting Department/New York State Government Finance Officers Association Annual Conference/Brian Krause

Sponsored By: Councilmember Kaminski, Supervisor Holtz

WHEREAS, the New York State Government Finance Officers Association Annual Conference is being held April 2 through April 4, 2014 in Albany, New York; AND

WHEREAS, Director of Administration and Finance Brian Krause has submitted a request for travel authorization along with the proper paperwork in a timely manner; AND

WHEREAS, the total cost to the Town shall not exceed \$887; AND

WHEREAS, these expenses have been budgeted by the Department; NOW, THEREFORE, BE IT

RESOLVED, that Director of Administration and Finance Brian Krause be and hereby is authorized to attend the New York State Government Finance Officers Association Annual Conference being held April 2 through April 4, 2014 in Albany, New York.

RESULT:	ADOPTED [UNANIMOUS]
MOVER:	Gerald Kaminski, Councilmember
SECONDER:	Mary Holtz, Supervisor
AYES:	Holtz, Rogowski, Markel, Kaminski, Wozniak, Benczkowski, Meyers

V. Suspension of Rules

Motion by Councilmember Markel; Seconded by Councilmember Rogowski to waive the Rules to Include the Following two (2) resolutions: 2014-182 and 2014-183. Motion Carried.
--



1. RESOLUTION 2014-182

Amend Notice to Bidders - Sewer Maintenance Building Addition & Renovations

Sponsored By: Councilmember Meyers, Supervisor Holtz

WHEREAS, by resolution dated February 19, 2014 (Resolution 2014-114) this Town Board authorized and directed the Town Clerk to publish a Notice to Bidders in connection with the Town of Cheektowaga Sewer Maintenance Building Addition and Renovations Project, AND

WHEREAS, the Notice to Bidders needed to be changed to allow bidders additional time in which to submit proposals, NOW, THEREFORE, BE IT

RESOLVED, that the Town Clerk be directed to republish an amended Notice to Bidders in connection with the Sewer Maintenance Building Addition and Renovations Project with sealed bids to be received and opened by the Town Clerk on the 26th day of March 2014 at 11:00 A.M. at a public bid opening to be held in the Council Chambers of the Cheektowaga Town Hall.



NOTICE TO BIDDERS (AMENDED)

Sealed proposals will be received and considered by the Town Board of the Town of Cheektowaga on Wednesday, March 26, 2014 at 11:00 A.M., Local Time, at the Town Hall, corner of Broadway and Union Roads, for the furnishing of all labor, materials, tools, equipment and incidentals required for General Construction Work including Electrical Work, HVAC Work and Plumbing Work for the Sewer Maintenance Building Addition and Renovations Project.

Information for bidders and specifications may be obtained from the Town Clerk at her office in said Town Hall.

This Notice to Bidders shall supersede a previously issued Notice to Bidders for the Sewer Maintenance Building Addition and Renovations Project (Resolution 2014-114), amending the bid opening date from March 19, 2014 to March 26, 2014.

The Town Board reserves the right to consider informal any bid not prepared and submitted in accordance with the provisions of the specifications and contract documents, and may waive any informalities, make an award to other than the low bidder, should it be in the best interest of the Town, or reject any or all bids.

By order of the Town Board of the Town of Cheektowaga, Erie County, New York.

Alice Magierski, Town Clerk

DATED: March 17, 2014

RESULT:	ADOPTED [UNANIMOUS]
MOVER:	Timothy J. Meyers, Councilmember
SECONDER:	Mary Holtz, Supervisor
AYES:	Holtz, Rogowski, Markel, Kaminski, Wozniak, Benczkowski, Meyers



2. RESOLUTION 2014-183

Acceptance of Easements Relating to 4989 Genesee Street

Sponsored By: Councilmember Meyers, Councilmember Markel

WHEREAS, as part of the development of 4989 Genesee Street, the Town of Cheektowaga has requested a storm sewer easement and declaration of easements and restrictions relating to the development of apartment buildings on the site, and

WHEREAS, the said documents have been signed and submitted to the Town for approval; and

WHEREAS, the Town Engineer and Town Attorney have reviewed these documents and have recommended that the Town accept same, NOW, THEREFORE, BE IT

RESOLVED, that this Town Board hereby accepts the above referenced documents; and BE IT FURTHER

RESOLVED, that the Town Attorney's Office be and hereby is directed to arrange for the filing of such documents in the Erie County Clerk's Office.

RESULT:	ADOPTED [UNANIMOUS]
MOVER:	Timothy J. Meyers, Councilmember
SECONDER:	Charles Markel, Councilmember
AYES:	Holtz, Rogowski, Markel, Kaminski, Wozniak, Benczkowski, Meyers

VI. Communications

A. Departmental Communications

1. **Minutes: Cheektowaga Planning Board - February 13, 2014**
2. **Minutes: Cheektowaga Conservation Advisory Council - February 6, 2014**

B. General Communications

1. **Summons & Complaint: Citimortgage, Inc vs. Nancy Vasquez & Town of Cheektowaga
Premises: 68 Cornell Drive**
2. **Notice of Claim: Paul Johnson vs. Town of Cheektowaga**
3. **Notice of Claim: Maryann Kromer vs. Town of Cheektowaga**

4. Notice of Claim: Kenneth Ruof, Jr. vs. Town of Cheektowaga

VII. Comments

A. Supervisor's Comments

B. Councilmember's Comments

C. Public Comments

VIII. Adjournment

Motion by Councilmember Holtz; Seconded by Councilmember Kaminski to adjourn the meeting at 7:27 PM.

Alice Magierski, Town Clerk



Town of Cheektowaga

Regular Meeting

~ Minutes ~

3301 Broadway
Cheektowaga, NY 14227
<http://www.town.cheektowaga.ny.us>

Alice Magierski
716-686-3400

Monday, April 7, 2014

6:45 PM

Council Chambers

I. Call to Order

6:45 PM Meeting called to order on April 7, 2014 at Council Chambers, 3301 Broadway St, Cheektowaga, NY.

Attendee Name	Organization	Title	Status	Arrived
Mary Holtz	Town of Cheektowaga	Supervisor	Present	
James P. Rogowski	Town of Cheektowaga	Councilmember	Present	
Charles Markel	Town of Cheektowaga	Councilmember	Present	
Gerald Kaminski	Town of Cheektowaga	Councilmember	Present	
Angela M. Wozniak	Town of Cheektowaga	Councilmember	Present	
Diane Benczkowski	Town of Cheektowaga	Councilmember	Present	
Timothy J. Meyers	Town of Cheektowaga	Councilmember	Present	

2. Additional Attendees

Patrick Bowen, P.E., Assistant Town Engineer
Ellen Fischer, Executive Director - Youth Board
Brian Krause, Director of Finance and Administration
Kevin Schenk, Town Attorney

II. Public Comment Period

III. Public Hearing

1. Rezoning of 432 Dingens Street - from C-Retail Business to MS-Motor Services

COMMENTS - Current Meeting:

This being the time and place advertised for a Public Hearing, the Supervisor directed the Town Clerk to present that such notice has been duly published and posted; upon the order of the Supervisor such proof was duly filed.

The Supervisor announced that the Town Board would hear all persons interested in the subject of the hearing. Comments were heard, after which the Supervisor declared the hearing closed, decision was reserved.

RESULT:	CLOSED [UNANIMOUS]
MOVER:	Charles Markel, Councilmember
SECONDER:	James P. Rogowski, Councilmember
AYES:	Holtz, Rogowski, Markel, Kaminski, Wozniak, Benczkowski, Meyers

IV. Resolutions



1. RESOLUTION 2014-185

Transfer of Funds-2014

Sponsored By: Supervisor Holtz, Councilmember Kaminski

BE IT RESOLVED, that the following transfer is hereby approved and made part hereof;

CDBG

FROM:	700.9009.0607	Village of Sloan/Smoke Detectors	\$1,000.00
	700.9010.0768	Village of Sloan/Signage	3,500.00
	700.5010.0674	Village of Depew/Narc.&Traffic Enforc.	6,746.15
	700.5012.0676	Village of Depew/Police Foot Patrols	6,010.53
	700.5012.0793	Village of Depew/Sen. Citizen Cen. Staff	3,214.52
TO:	700.9010.0710	Village of Sloan/Rec.Impr.&Facility Equip	\$4,500.00
	700.5013.0500	Village of Depew/Sidewalk Replacement	15,971.20

RESULT: **ADOPTED [UNANIMOUS]**

MOVER: Mary Holtz, Supervisor

SECONDER: Gerald Kaminski, Councilmember

AYES: Holtz, Rogowski, Markel, Kaminski, Wozniak, Benczkowski, Meyers



2. RESOLUTION 2014-186

Warrant

Sponsored By: Supervisor Holtz, Councilmember Kaminski

BE IT RESOLVED, that the following Vouchers & Warrants submitted to the Town of Cheektowaga prior to April 7, 2014 are hereby approved and made part hereof;

GENERAL FUND	\$3,563,984.65
RISK RETENTION FUND	788,260.63
NYS HOME PROGRAM	
DEBT	304,334.00
HUD HOUSING REHABILITATION FUND	1,604.96
SPECIAL DISTRICTS FUND	957,950.02
HIGHWAY FUND	631,627.05
CAPITAL FUND	8,602.80
TRUST & AGENCY FUND	9,324.22
HUD CDBG FUND	69,334.46
PART TOWN FUND	36,753.12
NYS AFFORDABLE HOUSING	113,419.06
	<hr/>
	\$6,485,194.97

RESULT:	ADOPTED [UNANIMOUS]
MOVER:	Mary Holtz, Supervisor
SECONDER:	Gerald Kaminski, Councilmember
AYES:	Holtz, Rogowski, Markel, Kaminski, Wozniak, Benczkowski, Meyers



3. RESOLUTION 2014-187

Award of Bid - Cold Milling of Various Town Highways Bid 2014-12

Sponsored By: Councilmember Kaminski, Supervisor Holtz

WHEREAS, a Notice to Bidders was published for the receipt of bids for the Cold Milling of Various Town Highways within the Town of Cheektowaga (Bid 2014-12), which bids were duly received and opened on April 2, 2014.

WHEREAS, one (1) bid was received and referred to the Town Engineer for analysis and tabulation, NOW, THEREFORE, BE IT

RESOLVED, that the contract for the Cold Milling of Various Town Highways in the Town of Cheektowaga for the year of 2014 be awarded to:

Swank Associated Companies, Inc.
200 Hunt Valley Road
New Kensington, PA. 15068

For the bid price of \$129,250.00, said being the lowest bid meeting the requirements of the specifications.

RESULT:	ADOPTED [UNANIMOUS]
MOVER:	Gerald Kaminski, Councilmember
SECONDER:	Mary Holtz, Supervisor
AYES:	Holtz, Rogowski, Markel, Kaminski, Wozniak, Benczkowski, Meyers



4. RESOLUTION 2014-188

Award of Bid - Manhole/Catch Basin Frames and Covers (Bid 2014-13)

Sponsored By: Councilmember Kaminski, Supervisor Holtz

WHEREAS, a Notice to Bidders was duly published for the receipt of bid for the furnishing of manhole/catch basin frames and covers (Bid 2014-13), which bids were duly received and opened on April 2, 2014, AND

WHEREAS, four (4) bids were received and referred to the Town Engineer for analysis and tabulation, NOW, THEREFORE, BE IT

RESOLVED, that the contract for the furnishing of manhole frames and covers be and hereby is awarded to:

Vellano Brothers, Inc.
10 Lancaster Parkway
Lancaster, New York 14086
684-7222

BID ITEM	FRAME & 24" DIA COVER (SET)	UNIT BID PRICE DELIVERED
I	Frame with 24" diameter self-sealing cover "CHEEKTOWAGA SANITARY"	\$235.00 per set
II	Frame with 24" diameter vented cover "CHEEKTOWAGA SANITARY"	\$219.00 per set

K&S Contractors Supply
1971 Gunnville Road
Lancaster, NY 14086

BID ITEM ALTERNATE

I	Catch Basin Frame with 26" square cover	\$160.00 per set
---	---	------------------

Attachments:
tabulation (PDF)

RESULT:	ADOPTED [UNANIMOUS]
MOVER:	Gerald Kaminski, Councilmember
SECONDER:	Mary Holtz, Supervisor
AYES:	Holtz, Rogowski, Markel, Kaminski, Wozniak, Benczkowski, Meyers



5. RESOLUTION 2014-189

Award of Bid for Asbestos Survey and Air Monitoring Services for Property Located at 42 Avery Place (BID 2014-14 LAW)

Sponsored By: Councilmember Markel, Supervisor Holtz

WHEREAS, pursuant to the Unsafe Buildings Law of the Town of Cheektowaga, this Town Board can require that unsafe buildings be either repaired or demolished; and

WHEREAS, the structures on property located at 42 Avery Place have experienced extensive deterioration and damage, and Nussbaumer & Clarke, Inc. determined that said structures are unsafe and recommended that they be demolished and removed; and

WHEREAS, by resolution adopted February 3, 2014, this Town Board ordered that the structures on said property be either repaired or demolished, and directed that the respective owner(s) or others responsible for the building on said property commence said repair or demolition work within 30 days; and

WHEREAS, more than 30 days have expired and no work has been commenced with respect to said property; and

WHEREAS, pursuant to the Unsafe Buildings Law, this Town Board can provide for the demolition of an unsafe building and assess the cost of same against the property; and

WHEREAS, prior to the demolition of said property, the Town needs to retain a firm to perform an asbestos survey and asbestos abatement plans for same; and

WHEREAS, on March 17, 2014, this Town Board issued a Notice to Bidders (Bid 2014-14 LAW) to various asbestos abatement firms and based on proposals submitted, the Town Attorney has recommended that this Town Board retain Buffalo Environmental Consultants, Inc., d/b/a AFI Environmental, to perform said asbestos survey, specifications and project monitoring work for the sum of \$2,977.25, and if required, a further sum of \$245.00 per day and \$7.00 per sample for additional air monitoring and sampling at the site, said proposal being the lowest responsible bid submitted; NOW, THEREFORE, BE IT

RESOLVED, that this Town Board hereby retains Buffalo Environmental Consultants, Inc., d/b/a AFI Environmental, Post Office Box 4049, Niagara Falls, New York 14304, to perform said asbestos survey and abatement work (if necessary) for 42 Avery Place, for the sum of \$2,977.25 and if required, a further sum of \$245.00 per day and \$7.00 per sample for additional air monitoring and sampling at the site; and BE IT FURTHER

RESOLVED, that the Supervisor be and hereby is directed to execute an agreement with Buffalo Environmental Consultants, Inc., d/b/a AFI Environmental, for said services; and BE IT FURTHER

RESOLVED, that moneys for said services shall be appropriated from budget line item number 0800-800-0440.

RESULT:	ADOPTED [UNANIMOUS]
MOVER:	Charles Markel, Councilmember
SECONDER:	Mary Holtz, Supervisor
AYES:	Holtz, Rogowski, Markel, Kaminski, Wozniak, Benczkowski, Meyers



6. RESOLUTION 2014-190

Retain Grant Consulting Firm

Sponsored By: Supervisor Holtz, Councilmember Kaminski

WHEREAS, the Town of Cheektowaga is in need of a grant consulting firm to assist the Town with obtaining grants from various sources, and

WHEREAS, the Town issued a Request for Proposals for these services and received proposals from several firms, and

WHEREAS, after conducting interviews of grants consulting firms, this Town Board has decided that KHEOPS Architecture and Engineering, DPC will provide the best services at the most reasonable cost, NOW, THEREFORE, BE IT

RESOLVED, that this Town Board hereby retains KHEOPS Architecture and Engineering, DPC to perform grant consulting services for the Town of Cheektowaga for one year at a total cost of \$24,000, and BE IT FURTHER

RESOLVED, that the Supervisor be and hereby is directed to execute an agreement with KHEOPS Architecture and Engineering, DPC for these services for one year, commencing on April 8, 2014 and terminating on April 7, 2015.

RESULT:	ADOPTED [UNANIMOUS]
MOVER:	Mary Holtz, Supervisor
SECONDER:	Gerald Kaminski, Councilmember
AYES:	Holtz, Rogowski, Markel, Kaminski, Wozniak, Benczkowski, Meyers



7. RESOLUTION 2014-191

Amended Call for Public Hearing - 432 Dingens Street Rezoning Request

Sponsored By: Councilmember Markel, Councilmember Rogowski

WHEREAS, Sunoco , Inc. R&M has made application and requested the rezoning of 432 Dingens Street from C-Retail Business to MS-Motor Services for the re-development of an existing gas station /convenience store at 432 Dingens Street, and

WHEREAS, notice of such hearing was duly sent to owners of property within 300 feet as required by Town Law; however, inadvertently, such notice was not published in the CHEEKTOWAGA BEE, NOW, THEREFORE BE IT

RESOLVED, that a further Public Hearing be held regarding said request under the provisions of the Zoning Law on April 21, 2014 at 6:45 P.M., at the Cheektowaga Town Hall, 3301 Broadway at the corner of Union Road.



Notice of Public Hearing

NOTICE IS HEREBY GIVEN that a further Public Hearing will be held by the Town Board of the Town of Cheektowaga, Erie County, New York at the Town Hall in the said Town of Cheektowaga, 3301 Broadway corner of Union Road on the 21st day of April, 2014 at 6:45 o'clock P.M., of said day for the purpose of considering the application of:

Sunoco, Inc. R&M

For the rezoning of 432 Dingens Street from from C-Retail Business to MS-Motor Services for the re-development of an existing gas station /convenience store at 432 Dingens Street.

All parties in interest and citizens will be given an opportunity to be heard in regard to such proposed application.

BY ORDER OF THE TOWN BOARD, Town of Cheektowaga, NY

Alice Magierski, TOWN CLERK



All that tract or parcel of land situate in Town of Cheektowaga, County of Erie, and State of New York, being known as Subdivision Lots 3 and 4 as shown on a map entitled "Shanley Street Extension Subdivision Plat", part of Farm Lots 147 and 148, Township 10 and Range 7, Holland Land Company, filed in the Erie County Clerk's Office on October 9, 1952 under Map cover 1791, and being more particularly bounded and described as follows:

Beginning at the point of intersection of the westerly line of Shanley Street (60 feet wide) and the northerly line of Dingens Street (73.5 feet wide); thence, North 81°13'45" West, on the

northerly line of said Dingens Street, a distance of 118.43 feet to a rebar found on the division line between the City of Buffalo on the west and the Town of Cheektowaga on the east; thence, North 08°25'50" East, on said division line, a distance of 118.61 feet to a point; thence, South 81°30'00" East, a distance of 118.57 feet to a point of the westerly line of said Shanley Street; thence, South 08°30'00" West, on the westerly line of said Shanley Street, a distance of 119.17 feet to the Point of Beginning. Said parcel containing 0.323 acres, more or less, described as Parcel A as filed in Book 9519 of Deeds, Page 551 in the Erie County Clerk's Office, and as shown on a map prepared by Bergmann Associates entitled "Property Map Sunoco, Inc., 422, 424, 428 & 432 Dingens Street", drawing number CM-1, dated August 26, 2013, last revised on September 30, 2013, said map to be filed in the Erie County Clerk's Office.

RESULT:	ADOPTED [UNANIMOUS]
MOVER:	Charles Markel, Councilmember
SECONDER:	James P. Rogowski, Councilmember
AYES:	Holtz, Rogowski, Markel, Kaminski, Wozniak, Benczkowski, Meyers



8. RESOLUTION 2014-192

Notice of Hearing for Demolition of 129 David Avenue

Sponsored By: Councilmember Markel, Supervisor Holtz

WHEREAS, the Supervising Code Enforcement Officer has received information that the building located at 129 David Avenue in the Town of Cheektowaga (S.B.L. No. 102.21-7-23) has become dangerous and unsafe to the general public and unfit for the purposes for which it may lawfully be used; and

WHEREAS, said building has been inspected and a written report of the condition has been completed by Nussbaumer & Clarke, Inc., duly authorized agent of the Town of Cheektowaga, setting forth its findings and recommendations in regard to the repair or demolition and removal of the building, and said written report describes extensive deterioration and damage to the building and premises and recommends that the building be demolished and removed as soon as possible; and

WHEREAS, the Town Board has fully considered such written report and has determined that the building is dangerous and unsafe to the general public and unfit for the purposes for which it may lawfully be used; NOW THEREFORE BE IT

RESOLVED, that this Town Board accepts the findings and recommendations of Nussbaumer & Clarke, Inc., dated March 25, 2014; and BE IT FURTHER

RESOLVED, that a notice shall be served, pursuant to Section 75-7 of the Cheektowaga Town Code, upon the owner, executor, administrator, agent, lessee or any person having a vested or contingent interest in such unsafe building as shown by the records of the Receiver of Taxes or of the County Clerk, which notice shall have the contents prescribed by Section 75-6 of said Town Code, including, but not limited to, a date, time and place for a hearing before the Town Board in relation to such dangerous and unsafe building, which hearing shall be scheduled not less than five business days from the date of service of the notice; and BE IT FURTHER

RESOLVED, that a hearing before this Board in relation to this dangerous and unsafe building shall be held on the 21st day of April 2014 at 6:45 P.M. at the Cheektowaga Town Hall, 3301 Broadway, Cheektowaga, New York, and BE IT FURTHER

RESOLVED, that the Code Enforcement Office and/or the Town Attorney's Office be and hereby are directed to serve notice of said hearing on all interested parties.

RESULT:	ADOPTED [UNANIMOUS]
MOVER:	Charles Markel, Councilmember
SECONDER:	Mary Holtz, Supervisor
AYES:	Holtz, Rogowski, Markel, Kaminski, Wozniak, Benczkowski, Meyers



9. RESOLUTION 2014-193

Notice to Bidders - 2014 Pool Maintenance Chemicals (Bid 2014-16)

Sponsored By: Councilmember Rogowski, Councilmember Wozniak

WHEREAS, the Town of Cheektowaga Facilities Department, Parks Division, annually requires Pool Maintenance Chemicals for 2014 (Bid 2014-16), NOW, THEREFORE BE IT

RESOLVED, that the Town Clerk be directed to publish a Notice To Bidders for the furnishing of Pool Maintenance Chemicals, AND BE IT FURTHER

RESOLVED, that specifications for said Pool Maintenance Chemicals may be obtained from the Town Clerk's Office in Cheektowaga Town Hall, AND BE IT FURTHER

RESOLVED, that sealed bids will be received on the 16th day of April, 2014 at 11:00 AM at a public bid opening to be held in the Council Chambers at Cheektowaga Town Hall.



Notice to Bidders

Sealed proposals will be received by the Town Clerk on April 16, 2014, at 11:00 AM at Town Hall, 3301 Broadway, for the furnishing of Pool Maintenance Chemicals for the year 2014 (Bid 2014-16).

Information for bidders and specifications may be obtained from the Town Clerk at her office in Town Hall.

The Town Board reserves the right to consider informal any bid not prepared and submitted in accordance with the provisions of the specifications and contract documents and may waive any informalities, make an award to other than the low bidder should it be in the best interest of the Town, or reject any or all bids.

By Order of the Town Board of the Town of Cheektowaga, Erie County, New York.

Alice Magierski, Town Clerk

April 7, 2014

RESULT:	ADOPTED [UNANIMOUS]
MOVER:	James P. Rogowski, Councilmember
SECONDER:	Angela M. Wozniak, Councilmember
AYES:	Holtz, Rogowski, Markel, Kaminski, Wozniak, Benczkowski, Meyers



10. RESOLUTION 2014-194

Notice to Bidders - 2014 Athletic White Stripe (Bid 2014-17)

Sponsored By: Councilmember Rogowski, Councilmember Wozniak

WHEREAS, the Town of Cheektowaga Facilities Department, Parks Division requires Athletic White Stripe for the purpose of lining athletic fields for 2014 (Bid 2014-17), NOW, THEREFORE, BE IT

RESOLVED, that the Town of Cheektowaga be directed to publish a Notice to Bidders for the purchase of Athletic White Stripe, AND BE IT FURTHER

RESOLVED, that specifications for said Athletic White Stripe may be obtained from the Town Clerks Office in Cheektowaga Town Hall, AND BE IT FURTHER

RESOLVED, that sealed bids will be received on the 16th day of April, 2014 at 11:00AM at a public bid opening to be held in the Council Chambers at Cheektowaga Town Hall



Notice to Bidders

Sealed proposals will be received by the Town clerk on April 16, 2014, at 11:00 AM at the Town Hall, 3301 Broadway, for the supplying of Athletic White Stripe for the year 2014 (Bid 2014-17).

Information for bidders and specifications may be obtained from the Town Clerk at her office in Town Hall.

The Town Board reserves the right to consider informal any bid not prepared and submitted in accordance with the provisions of the specifications and contract documents and may waive any informalities, make an award to other than the low bidder should it be in the best interest of the Town, or reject any or all bids.

Alice Magierski, Town Clerk

April 7, 2014

RESULT:	ADOPTED [UNANIMOUS]
MOVER:	James P. Rogowski, Councilmember
SECONDER:	Angela M. Wozniak, Councilmember
AYES:	Holtz, Rogowski, Markel, Kaminski, Wozniak, Benczkowski, Meyers



11. RESOLUTION 2014-195

Notice to Bidders - Topsoil (Bid #2014-18)

Sponsored By: Councilmember Kaminski, Supervisor Holtz

WHEREAS, it is in order that bids be advertised for the purchase of Topsoil for the 2014 (Bid 2014/18) calendar year for use by the Cheektowaga Highway Department and various other departments in the Town, AND

WHEREAS, the Cheektowaga Engineering Department was hereby requested to prepare specifications, NOW, THEREFORE, BE IT

RESOLVED, that this request be granted and that the Town Clerk be directed to publish a Notice to Bidders in connection with the purchase of Topsoil, said notice to be published in the CHEEKTOWAGA BEE, AND, BE IT FURTHER

RESOLVED, that sealed bids will be received on the 16th day of April, 2014 at 11:00 am at a public bid opening to be held in the Council Chambers at the Cheektowaga Town Hall.



NOTICE TO BIDDERS

Sealed proposals will be received and considered by the Town Board of the Town of Cheektowaga on April 16, 2014 at 11:00 am at the Town Hall, corner of Broadway and Union Roads, Cheektowaga, New York, for the purchase of Topsoil (Bid 2014-18) by the Town of Cheektowaga for the calendar year 2014.

Information for bidders and specifications may be obtained from the Town Clerk at her office in said Town.

Proposals shall be submitted in a sealed envelope, plainly marked on the outside "Topsoil" and submitted to the Town Clerk prior to bid opening.

No bidder may withdraw his bid within forty-five (45) days after the actual date of the opening thereof.

The Town Board reserves the right to consider informal any bid not prepared and submitted in accordance with the provisions of the specifications and contract documents, and may waive any informalities, make an award to other than the low bidder, should it be in the best interest of the Town, or reject any and all bids.

By order of the Town Board of the Town of Cheektowaga, Erie County, New York.

Alice Magierski, Town Clerk

DATED: April 7, 2014

RESULT:	ADOPTED [UNANIMOUS]
MOVER:	Gerald Kaminski, Councilmember
SECONDER:	Mary Holtz, Supervisor
AYES:	Holtz, Rogowski, Markel, Kaminski, Wozniak, Benczkowski, Meyers



12. RESOLUTION 2014-196

Notice to Bidders - Sidewalk Replacement / ADA Ramp Installation (Bid #2014-19)

Sponsored By: Councilmember Kaminski, Supervisor Holtz

WHEREAS, it is in order that bids be advertised for Sidewalk Replacement / ADA Ramp Installation in various locations in the Town of Cheektowaga for the year 2014 (Bid 2014-19), AND

WHEREAS, the Cheektowaga Engineering Department has prepared specifications for the aforesaid project, NOW, THEREFORE, BE IT

RESOLVED, that the Town Clerk be directed to publish a Notice to Bidders for Sidewalk Replacement / ADA Ramp Installation, said notice to be published in the CHEEKTOWAGA BEE, AND, BE IT FURTHER

RESOLVED, that sealed bids will be received on the 16th day of April, 2014 at 11:00 am at a public bid opening to be held in the Council Chambers in the Cheektowaga Town Hall.



NOTICE TO BIDDERS

Sealed proposals will be received and considered by the Town Board of the Town of Cheektowaga on April 16, 2014 at 11:00 am at the Town Hall, corner of Broadway & Union Roads, Cheektowaga, New York, for Sidewalk Replacement / ADA Ramp Installation in the Town of Cheektowaga for the calendar year 2014 (Bid 2014-19)

Information for bidders and specifications may be obtained from the Town Clerk at her office in said Town.

Proposals shall be submitted in a sealed envelope, plainly marked on the outside "Bid for Sidewalk Replacement / ADA Ramp Installation" and submitted to the Town Clerk prior to bid opening.

No bidder may withdraw his bid within forty-five (45) days after the actual date of the opening thereof.

The Town Board reserves the right to consider informal any bid not prepared and submitted in accordance with the provisions of the specifications and contract documents, and may waive any informalities, make an award to other than the low bidder, should it be in the best interest of the Town, or reject any and all bids.

By order of the Town Board of the Town of Cheektowaga, Erie County, New York.

Alice Magierski, Town Clerk

DATED: April 7, 2014

RESULT:	ADOPTED [UNANIMOUS]
MOVER:	Gerald Kaminski, Councilmember
SECONDER:	Mary Holtz, Supervisor
AYES:	Holtz, Rogowski, Markel, Kaminski, Wozniak, Benczkowski, Meyers



13. RESOLUTION 2014-197

Notice to Bidders - Equipment & Operators for Public Works Projects (Bid #2014-20)

Sponsored By: Councilmember Meyers, Supervisor Holtz

WHEREAS, it is in order that bids be advertised for the furnishing of Equipment and Operators for Public Works Projects (Bid 2014-20) in the Town of Cheektowaga for the period of April 21, 2014 to April 20, 2015, AND

WHEREAS, the Cheektowaga Engineering Department was hereby requested to prepare specifications, NOW, THEREFORE, BE IT

RESOLVED, that this request be granted and that the Town Clerk be directed to publish a Notice to Bidders in connection with the furnishing of Equipment & Operators for Public Works Projects, said notice to be published in the CHEEKTOWAGA BEE, AND, BE IT FURTHER

RESOLVED, that sealed bids will be received on the 16th day of April, 2014 at 11:00 am at a public bid opening to be held in the Council Chambers at the Cheektowaga Town Hall.



NOTICE TO BIDDERS

Sealed proposals will be received and considered by the Town Board of the Town of Cheektowaga on April 16, 2014 at 11:00 am, at the Town Hall, corner of Broadway and Union Roads, Cheektowaga, New York, for the furnishing of Equipment and Operators for Public Works Projects (Bid 2014-20) in the Town of Cheektowaga, effective April 21, 2014 to April 20, 2015.

Information for bidders and specifications may be obtained from the Town Clerk at her office in said Town.

Proposals shall be submitted in a sealed envelope, plainly marked on the outside "Bid for Furnishing of Equipment and Operators for Public Works Projects" and submitted to the Town Clerk prior to bid opening.

No bidder may withdraw his bid within forty-five (45) days after the actual date of the opening thereof.

The Town Board reserves the right to consider informal any bid not prepared and submitted in accordance with the provisions of the specifications and contract documents, and may waive any informalities, make an award to other than the low bidder, should it be in the best interest of the Town, or reject any and all bids.

By order of the Town Board of the Town of Cheektowaga, Erie County, New York.

Please be advised that in accordance with a resolution adopted by the Cheektowaga

Town Board on December 23, 2008, effective December 24, 2008, contractors on all construction contracts with a value in excess of \$1,000,000 and up to \$3,000,000 **must** have apprenticeship agreements appropriate for the type and scope of work to be performed that have been registered with and approved by the New York State Commissioner of Labor in accordance with Article 23 of the New York Labor Law.

Alice Magierski, Town Clerk

DATED: April 7, 2014

RESULT:	ADOPTED [6 TO 0]
MOVER:	Timothy J. Meyers, Councilmember
SECONDER:	Mary Holtz, Supervisor
AYES:	Holtz, Rogowski, Markel, Kaminski, Benczkowski, Meyers
ABSTAIN:	Angela M. Wozniak



14. RESOLUTION 2014-198

Authorize Supervisor to Execute Agreement for Pick-Up of Brush, Grindings, and Other Debris

Sponsored By: Councilmember Kaminski, Supervisor Holtz

WHEREAS, the Town Highway Department is responsible for the pickup and disposition of brush grindings, logs, leaves, and soil from various locations within the Town; and

WHEREAS, Zoladz Construction Co., Inc., ("Zoladz") has contacted the Superintendent of Highways with a proposal wherein Zoladz would pick up all brush grindings, logs, leaves, and soil collected by the Highway Department from Highway Department property and dispose of same at no cost to the Town; and

WHEREAS, the Superintendent of Highways has recommended that the Town accept the Contractor's proposal; and

WHEREAS, the Town Attorney's Office has prepared an Agreement regarding said proposal; NOW THEREFORE, BE IT

RESOLVED, that the Supervisor be and hereby is authorized and directed to execute the aforesaid Agreement with Zoladz Construction Co., Inc., under the terms and conditions set forth therein.

RESULT:	ADOPTED [UNANIMOUS]
MOVER:	Gerald Kaminski, Councilmember
SECONDER:	Mary Holtz, Supervisor
AYES:	Holtz, Rogowski, Markel, Kaminski, Wozniak, Benczkowski, Meyers



15. RESOLUTION 2014-199

Authorize Supervisor to Execute Agreement with Chamber of Commerce

Sponsored By: Supervisor Holtz, Councilmember Kaminski

WHEREAS, the Cheektowaga Chamber of Commerce performs many activities which promote the Town of Cheektowaga to businesses, visitors and residents, and

WHEREAS, Section 64(14) of the Town Law permits the Town of Cheektowaga to supply publicity fund moneys to the Cheektowaga Chamber of Commerce based on these services provided by the Chamber to the Town, NOW, THEREFORE, BE IT

RESOLVED, that this Town Board hereby approves publicity funding in the amount of \$10,000.00 to the Cheektowaga Chamber of Commerce for calendar year 2014, and BE IT FURTHER

RESOLVED, that the Supervisor be and hereby is authorized and directed to execute an agreement with the Cheektowaga Chamber of Commerce, which agreement will detail the services to be performed by the Chamber of Commerce for the benefit of the Town in 23014.

RESULT:	ADOPTED [UNANIMOUS]
MOVER:	Mary Holtz, Supervisor
SECONDER:	Gerald Kaminski, Councilmember
AYES:	Holtz, Rogowski, Markel, Kaminski, Wozniak, Benczkowski, Meyers



16. RESOLUTION 2014-200

Authorize Supervisor to Execute License Agreement with True Vine Christian Center Church

Sponsored By: Councilmember Rogowski, Councilmember Wozniak

WHEREAS, the Town of Cheektowaga is the owner of a vacant lot at 2289 Genesee Street (corner of Genesee Street and Avery Place) in the Town of Cheektowaga; and

WHEREAS, True Vine Christian Center Church has requested use of said vacant lot, which is across the street from the church, on Sunday, June 8, 2014 from 1:00 p.m. to 5:00 p.m. for their Children's Day Celebration; and

WHEREAS, True Vine Christian Center Church has offered to mow the grass on the vacant lot in order to accommodate the church festivities on June 8, 2014 and to clean up the property after the event; and

WHEREAS, the Town Attorney's Office has prepared a License Agreement with True Vine Christian Center Church, setting forth the terms and conditions under which the church may use said Town property; NOW, THEREFORE, BE IT

RESOLVED, that the Supervisor be and hereby is authorized and directed to execute a License Agreement with True Vine Christian Center Church on behalf of the Town of Cheektowaga.

RESULT:	ADOPTED [UNANIMOUS]
MOVER:	James P. Rogowski, Councilmember
SECONDER:	Angela M. Wozniak, Councilmember
AYES:	Holtz, Rogowski, Markel, Kaminski, Wozniak, Benczkowski, Meyers



17. RESOLUTION 2014-201

Authorize Municipal Cooperation Agreement with Village of Sloan

Sponsored By: Councilmember Kaminski, Supervisor Holtz

WHEREAS, the Village of Sloan requested that the Town of Cheektowaga Highway Department assist them in the paving of certain streets in said municipalities, and

WHEREAS, the Town of Cheektowaga Superintendent of Highways is willing to assist said municipalities as requested, and

WHEREAS, before the Town Superintendent of Highways can provide said services outside of the jurisdiction of the Town Highway District, the Town Board must authorize same, and

WHEREAS, Article 5-G of the General Municipal Law and Section 142-d of the Highway Law authorize this Town Board to enter into agreements with other municipalities to perform this work, NOW, THEREFORE, BE IT

RESOLVED, that the Supervisor be and hereby is authorized and directed to execute municipal cooperation agreements with the Village of Sloan to pave designated streets in said municipalities, and BE IT FURTHER

RESOLVED, that moneys received from said municipalities for the provision of the requested services shall be deposited into the proper accounts as determined by the Director of Administration and Finance.

RESULT:	ADOPTED [UNANIMOUS]
MOVER:	Gerald Kaminski, Councilmember
SECONDER:	Mary Holtz, Supervisor
AYES:	Holtz, Rogowski, Markel, Kaminski, Wozniak, Benczkowski, Meyers



18. RESOLUTION 2014-202

Authorize Purchase of Copy Machines for Highway, Building, and Employee Relations Departments

Sponsored By: Supervisor Holtz, Councilmember Benczkowski

WHEREAS, due to heavy usage and age, the copy machines in the Highway, Building, and Personnel Departments are experiencing many breakdowns requiring frequent service calls and maintenance; and

WHEREAS, Erie 1 Board of Cooperative Educational Services ("BOCES") solicited bids for the purchase of photocopiers for use by them, school districts and municipalities in the Western New York area; and

WHEREAS, New York State General Municipal Law, Section 103, authorizes the purchase by the Town of photocopiers under contracts let by any other agency of the State, provided said contract was let in a manner that constituted competitive bidding consistent with State Law, and further, that provision was made in the bid documents enabling municipalities to utilize said bid award thereby eliminating the need for competitive bidding by the Town and allowing "piggybacking" off BOCES' bid; and

WHEREAS, BOCES' bid documents and award contained such provisions; and

WHEREAS, a local vendor, Eagle Systems, Inc., was a successful bidder and was awarded the bid by BOCES (BOCES Bid #CE060713C) and is an authorized dealer for Toshiba copiers under said contract; and

WHEREAS, the Town of Cheektowaga solicited quotations from Eagle Systems to purchase copy machines for the Highway, Building, and Employee Relations Departments; NOW, THEREFORE, BE IT

RESOLVED, that this Town Board agrees to purchase copy machines through the contract awarded by Erie 1 Board of Cooperative Educational Services ("BOCES"), Bid #CE060713C, utilizing a local vendor/authorized dealer, Eagle Systems, Inc., 2421 Harlem Road, Cheektowaga, New York 14225 as follows:

Highway Department:	Toshiba eStudio 3055c, price not to exceed \$4,792.00
Building Department	Toshiba eStudio 3055c, price not to exceed \$4,792.00
Employee Relations Dept.:	Toshiba eStudio 3055c, price not to exceed \$4,552.00

said pricing to include delivery, surge protectors, installation on servers and three workstations each, and removal and return of the hard drives on the present copiers to the Town of Cheektowaga for destruction; and BE IT FURTHER

RESOLVED, that the cost per copy for maintenance and supplies for said copiers for a guaranteed two-year period, commencing on the date of installation of said copiers, will be \$0.008 per black and white copy and \$0.06 per color copy; and BE IT FURTHER

RESOLVED, that moneys for said purchase shall be appropriated from equipment line

items of the respective departments; and BE IT FURTHER

RESOLVED, that the Supervisor be and hereby is authorized and directed to execute all documents and maintenance agreements with Eagle Systems, Inc., to effectuate the purchase, subject to the review and approval of same by the Town Attorney.

RESULT:	ADOPTED [UNANIMOUS]
MOVER:	Mary Holtz, Supervisor
SECONDER:	Diane Benczkowski, Councilmember
AYES:	Holtz, Rogowski, Markel, Kaminski, Wozniak, Benczkowski, Meyers



19. RESOLUTION 2014-203

Renewal of Property Insurance

Sponsored By: Supervisor Holtz, Councilmember Kaminski

WHEREAS, the Town's Property Insurance Coverage expires on March 30, 2014; and

WHEREAS, Holfoth Risk Management, the Town's insurance consultant, solicited proposals for the renewal of the Town's property insurance coverage; and

WHEREAS, after review of the proposals received, Holfoth Risk Management recommended that the Town of Cheektowaga accept the proposal from CNA Insurance Company for \$74,973.00 for the following listed options:

<u>Coverage</u>	<u>Limits</u>	<u>Deductible</u>
Buildings, Contents	\$70,672,497	\$25,000
Equipment Floater	\$3,983,063	\$ 2,500
Flood (non Flood Zones)	\$5,000,000	\$25,000
Earthquake	\$1,000,000	\$25,000

, and

WHEREAS, Holfoth Risk Management has also recommended that the Town of Cheektowaga accept the proposal from Allianz Global for the following vehicle physical damage insurance for \$13,690:

<u>Limits</u>	<u>Deductible</u>
\$3,000,000	\$10,000

, and

WHEREAS, this Town Board wishes to award the above referenced Town's property insurance to CNA Insurance Company and Allianz; NOW, THEREFORE, BE IT

RESOLVED, that this Town Board hereby awards the Town's Buildings and Contents property insurance as outlined above to CNA Insurance Company (through Lawley Service, Inc.) for the period from March 30, 2014 to March 30, 2015 for a premium of \$74,973.00; and BE IT FURTHER

RESOLVED, that this Town Board hereby awards the Town's Vehicle Physical Property Damage Insurance to Allianz Global for the period March 30, 2014 to March 30, 2015 to Allianz Global, and BE IT FURTHER

RESOLVED, that the Supervisor be and hereby is authorized and directed to execute any and all documents to effectuate this property insurance coverage.

RESULT:	ADOPTED [UNANIMOUS]
MOVER:	Mary Holtz, Supervisor
SECONDER:	Gerald Kaminski, Councilmember
AYES:	Holtz, Rogowski, Markel, Kaminski, Wozniak, Benczkowski, Meyers



20. RESOLUTION 2014-204

Special Event - Firefighters Recognition Day

Sponsored By: Councilmember Rogowski, Councilmember Meyers

WHEREAS, by resolution dated May 1, 1995, this Town Board adopted a Special Events policy, which requires anyone wishing to hold a special event in the Town to file an application and supporting documentation, fees, etc. to the Town Clerk prior to the special event; and

WHEREAS, Councilmember James Rogowski has made application to hold the Annual Firefighters Recognition Day in the Town of Cheektowaga, Sunday, June 22nd, 2014

WHEREAS, this Board has reviewed the aforementioned application, which application has been approved by the Facilities Department, Police Department, Highway Department and the Department of Recreation & Youth Services, and has no objection to same; and

WHEREAS, due to the nature of the event, this Town Board hereby waives the following requirements:

- Submittal of plan for sanitary facilities;
- Submittal of site plan;
- Submittal of Security Plan;
- Submittal of Fire Prevention/Emergency Services Plan;

NOW, THEREFORE, BE IT

RESOLVED, that this Town Board hereby approves the aforementioned application of Councilmember James Rogowski for the aforementioned Annual Firefighters Recognition Day in the Town of Cheektowaga to be held Sunday, June 22, 2014, at Cheektowaga Town Park from dawn to dusk.

RESULT:	ADOPTED [UNANIMOUS]
MOVER:	James P. Rogowski, Councilmember
SECONDER:	Timothy J. Meyers, Councilmember
AYES:	Holtz, Rogowski, Markel, Kaminski, Wozniak, Benczkowski, Meyers



21. RESOLUTION 2014-205

Special Event - Independence Day Parade and Celebration

Sponsored By: Councilmember Rogowski, Councilmember Meyers

WHEREAS, by resolution dated May 1, 1995, this Town Board adopted a Special Events policy, which requires anyone wishing to hold a special event in the Town to file an application and supporting documentation, fees, etc. to the Town Clerk prior to the special event, and

WHEREAS, the Cheektowaga Patriotic Commission has made application to hold its Independence Day Parade and Celebration on Thursday, July 3rd, 2014 from 5:00 p.m - 11:00 p.m.; and on Friday, July 4th, 2014 from Noon - 11:00 p.m. at Cheektowaga Town Park, and said Parade to be held on July 4th, 2014 starting at 12:00 p.m., beginning on Walden Avenue to Harlem Road and ending at Town Park; and

WHEREAS, this Board has reviewed the aforementioned application, which application has been approved by the Police Department, Highway Department and the Facilities Department, and has no objection to same, and

WHEREAS, due to the nature of the event, this Town Board hereby waives the following requirements:

- . Submittal of plan for sanitary facilities;
- . Submittal of site plan;
- . Submittal of Security Plan;
- . Submittal of Fire Prevention/Emergency Services Plan;

NOW, THEREFORE, BE IT

RESOLVED, that this Town Board hereby approves the aforementioned application of the Cheektowaga Patriotic Commission for said celebration and parade to be held on July 3rd and 4th, 2014; and BE IT FURTHER

RESOLVED, that the Chief of Police be and hereby is directed to provide traffic safety and escort services for such parade and to ensure compliance with Section 1660(a)(6) of the Vehicle and Traffic Law.

RESULT:	ADOPTED [UNANIMOUS]
MOVER:	James P. Rogowski, Councilmember
SECONDER:	Timothy J. Meyers, Councilmember
AYES:	Holtz, Rogowski, Markel, Kaminski, Wozniak, Benczkowski, Meyers



22. RESOLUTION 2014-206

Special Event - Infant of Prague Church Lawn Fete

Sponsored By: Councilmember Meyers, Councilmember Rogowski

WHEREAS, by resolution dated May 1, 1995, this Town Board adopted a Special Events policy, which requires anyone wishing to hold a special event in the Town to file an application and supporting documentation, fees, etc. to the Town Clerk prior to the special event, AND

WHEREAS, Infant of Prague Church has made application to hold its annual Church Lawn Fete on Friday, August 22nd (11:00 a.m. - 12:00 a.m.) and Saturday, August 23rd, 2014 (11:00 a.m. - 12:00 a.m.) on Church grounds; and, as a result of this Lawn Fete, they are also requesting a two (2) block street closing (Foisset Avenue from Cleveland Drive to the end of Church property) from Tuesday, August 19th at 8:00 a.m. until Sunday, August 24th at Midnight, AND

WHEREAS, this Board has reviewed the aforementioned application, which application has been approved by the Police Department, Highway Department and the Facilities Department, and has no objection to same, AND

WHEREAS, due to the nature of the event, this Town Board hereby waives the following requirements:

- 1) Submittal of plan for sanitary facilities;
- 2) Submittal of site plan;
- 3) Requirement that application be made at least 60 days prior to the date of the special event;
- 4) Submittal of Security Plan;
- 5) Submittal of Fire Prevention/Emergency Services Plan; NOW, THEREFORE, BE

IT

RESOLVED, that this Town Board hereby approves the aforementioned application of Infant of Prague Church for the said Lawn Fete and two (2) block street closing, as listed above; AND BE IT FURTHER

RESOLVED, that the Town Clerk shall forward a copy of this resolution to the Chief of Police Dave Zack.

RESULT:	ADOPTED [UNANIMOUS]
MOVER:	Timothy J. Meyers, Councilmember
SECONDER:	James P. Rogowski, Councilmember
AYES:	Holtz, Rogowski, Markel, Kaminski, Wozniak, Benczkowski, Meyers



23. RESOLUTION 2014-207

Special Event - "Walk to Remember"

Sponsored By: Councilmember Rogowski, Councilmember Meyers

WHEREAS, by resolution dated May 1, 1995, this Town Board adopted a Special Events policy, which requires any one wishing to hold a special event in the Town to file an application and supporting documentation, fees, etc. to the Town Clerk prior to the special event, and

WHEREAS, the Perinatal Bereavement Network has made application to hold a "Walk to Remember", dedicated to the thousands of babies that die each year through miscarriage, ectopic pregnancy, stillbirth or early infant death, at the Lions Pavilion in Cheektowaga Town Park on Sunday, October 12, 2014 from 8:00 A.M. to 3:00 P.M.; and

WHEREAS, this Board has reviewed the aforementioned application, which application has been approved by the Police Department, Facilities Department and Youth and Recreational Services Department, and has no objection to same, and

WHEREAS, due to the nature of the event, this Town Board hereby waives the following requirements:

- . Submittal of plan for sanitary facilities;
- . Submittal of site plan;
- . Submittal of Security Plan;
- . Submittal of Fire Prevention/Emergency Services Plan.

NOW, THEREFORE, BE IT

RESOLVED, that this Town Board hereby approves the aforementioned application of Perinatal Bereavement Network for the aforementioned "Walk to Remember" in Cheektowaga Town Park on Sunday, October 12, 2014.

RESULT:	ADOPTED [UNANIMOUS]
MOVER:	James P. Rogowski, Councilmember
SECONDER:	Timothy J. Meyers, Councilmember
AYES:	Holtz, Rogowski, Markel, Kaminski, Wozniak, Benczkowski, Meyers



24. RESOLUTION 2014-208

Special Event - War of 1812 Cemetery Ceremony

Sponsored By: Councilmember Rogowski, Councilmember Meyers

WHEREAS, by resolution dated May 1, 1995, this Town Board adopted a Special Events policy, which requires anyone wishing to hold a special event in the Town to file an application and supporting documentation, fees, etc. to the Town Clerk prior to the special event, and

WHEREAS, the War of 1812 Cemetery Committee has made application to hold a War of 1812 Cemetery Commemoration Ceremony on Sunday, June 8th, 2014 beginning at 11:30 A.M. at the War of 1812 Cemetery on Aero Drive;, AND

WHEREAS, this Board has reviewed the aforementioned application, which application has been approved by the Cheektowaga Police Department, Facilities Department and Highway Department and has no objection to same, and

WHEREAS, due to the nature of the event, this Town Board hereby waives the following requirements:

1. Submittal of plan for sanitary facilities;
2. Submittal of site plan;
3. Submittal of Security Plan;
4. Submittal of Fire Prevention/Emergency Services Plan.

NOW, THEREFORE, BE IT

RESOLVED, that this Town Board hereby approves the aforementioned application of the War of 1812 Cemetery Committee for the aforementioned Ceremony to be held on Sunday, June 8th, 2014.

RESULT:	ADOPTED [UNANIMOUS]
MOVER:	James P. Rogowski, Councilmember
SECONDER:	Timothy J. Meyers, Councilmember
AYES:	Holtz, Rogowski, Markel, Kaminski, Wozniak, Benczkowski, Meyers



25. RESOLUTION 2014-209

Unsafe-Unsecured / 327 Cleveland Drive

Sponsored By: Councilmember Markel, Supervisor Holtz

WHEREAS, Town of Cheektowaga Law for the Administration and Enforcement of the Codes of New York State; and the Property Maintenance Code of New York State require that all vacant structures and premises shall be maintained in clean, safe, secure and sanitary conditions so as not to cause a blighting problem or adversely affect the public health or safety and all nuisances abated, AND

WHEREAS, the Town of Cheektowaga has received notification of an unsafe structure and premises located at 327 Cleveland Drive, Cheektowaga, New York SBL# 80.17-13-2 that is a danger to the safety of others, and records kept by the Assessors Office identify Deborah A. Rodoski, 38 Lorraine Place, West Seneca, NY 14224 and Marion J. Rybzyński, 327 Cleveland Drive, Buffalo, New York 14215, as the owner AND

WHEREAS, an inspection of such premises was conducted at 327 Cleveland Drive, by the Housing and Neighborhood Preservation Office, AND

WHEREAS, such inspection found the premises to be deteriorated, vacant, a hazard, and a danger to the safety and well being of others, AND

WHEREAS, the Town of Cheektowaga Housing and Neighborhood Preservation Office properly notified the property owner in accordance with the Town of Cheektowaga Law for the Administration and Enforcement of the Codes of New York State, and the owner failed to take actions to safeguard the premises, AND

WHEREAS, these conditions require the Town of Cheektowaga Housing and Neighborhood Preservation Office to take immediate steps to safeguard the premises to protect the health and safety of others and abate all nuisances, NOW, THEREFORE BE IT

RESOLVED, that pursuant to Section 70-7A.(5) and Section 70-8 of the Town of Cheektowaga Law for the Administration and Enforcement of the Codes of New York State that the vacant structure premises be safeguarded and all nuisances abated; and all costs incurred be assessed against the property hereinbefore described.

RESULT:	ADOPTED [UNANIMOUS]
MOVER:	Charles Markel, Councilmember
SECONDER:	Mary Holtz, Supervisor
AYES:	Holtz, Rogowski, Markel, Kaminski, Wozniak, Benczkowski, Meyers



26. RESOLUTION 2014-210

Unsafe-Unsecured / 129 David Avenue

Sponsored By: Councilmember Markel, Supervisor Holtz

WHEREAS, Town of Cheektowaga Law for the Administration and Enforcement of the Codes of New York State; and the Property Maintenance Code of New York State require that all vacant structures and premises shall be maintained in clean, safe, secure and sanitary conditions so as not to cause a blighting problem or adversely affect the public health or safety and all nuisances abated, AND

WHEREAS, the Town of Cheektowaga has received notification of an unsafe structure and premises located at 129 David Avenue, Cheektowaga, New York SBL# 102.21-7-23 that is a danger to the safety of others, and records kept by the Assessors Office identify Robin Ann Krzeminski and James O'Brien, 87 Halstead Avenue, Unit 3, Buffalo, New York 14212, as the owner AND

WHEREAS, an inspection of such premises was conducted at 129 David Avenue, by the Housing and Neighborhood Preservation Office, AND

WHEREAS, such inspection found the premises to be deteriorated, vacant, a hazard, and a danger to the safety and well being of others, AND

WHEREAS, the Town of Cheektowaga Housing and Neighborhood Preservation Office properly notified the property owner in accordance with the Town of Cheektowaga Law for the Administration and Enforcement of the Codes of New York State, and the owner failed to take actions to safeguard the premises, AND

WHEREAS, these conditions require the Town of Cheektowaga Housing and Neighborhood Preservation Office to take immediate steps to safeguard the premises to protect the health and safety of others and abate all nuisances, NOW, THEREFORE BE IT

RESOLVED, that pursuant to Section 70-7A.(5) and Section 70-8 of the Town of Cheektowaga Law for the Administration and Enforcement of the Codes of New York State that the vacant structure premises be safeguarded and all nuisances abated; and all costs incurred be assessed against the property hereinbefore described.

RESULT:	ADOPTED [UNANIMOUS]
MOVER:	Charles Markel, Councilmember
SECONDER:	Mary Holtz, Supervisor
AYES:	Holtz, Rogowski, Markel, Kaminski, Wozniak, Benczkowski, Meyers



27. RESOLUTION 2014-211

Unsafe-Unsecured / 22 Gruner Road

Sponsored By: Councilmember Markel, Supervisor Holtz

WHEREAS, Town of Cheektowaga Law for the Administration and Enforcement of the Codes of New York State; and the Property Maintenance Code of New York State require that all vacant structures and premises shall be maintained in clean, safe, secure and sanitary conditions so as not to cause a blighting problem or adversely affect the public health or safety and all nuisances abated, AND

WHEREAS, the Town of Cheektowaga has received notification of an unsafe structure and premises located at 22 Gruner Road, Cheektowaga, New York SBL# 113.01-1-5 that is a danger to the safety of others, and records kept by the Assessors Office identify Robert M. Schultz, 2164 Jefferson Avenue, Naples, FL 34112, as the owner AND

WHEREAS, an inspection of such premises was conducted at 22 Gruner Road, by the Housing and Neighborhood Preservation Office, AND

WHEREAS, such inspection found the premises to be deteriorated, vacant, a hazard, and a danger to the safety and well being of others, AND

WHEREAS, the Town of Cheektowaga Housing and Neighborhood Preservation Office properly notified the property owner in accordance with the Town of Cheektowaga Law for the Administration and Enforcement of the Codes of New York State, and the owner failed to take actions to safeguard the premises, AND

WHEREAS, these conditions require the Town of Cheektowaga Housing and Neighborhood Preservation Office to take immediate steps to safeguard the premises to protect the health and safety of others and abate all nuisances, NOW, THEREFORE BE IT

RESOLVED, that pursuant to Section 70-7A.(5) and Section 70-8 of the Town of Cheektowaga Law for the Administration and Enforcement of the Codes of New York State that the vacant structure premises be safeguarded and all nuisances abated; and all costs incurred be assessed against the property hereinbefore described.

RESULT:	ADOPTED [UNANIMOUS]
MOVER:	Charles Markel, Councilmember
SECONDER:	Mary Holtz, Supervisor
AYES:	Holtz, Rogowski, Markel, Kaminski, Wozniak, Benczkowski, Meyers



28. RESOLUTION 2014-212

Unsafe-Unsecured / 81 Saint Felix Ave

Sponsored By: Councilmember Markel, Supervisor Holtz

WHEREAS, Town of Cheektowaga Law for the Administration and Enforcement of the Codes of New York State; and the Property Maintenance Code of New York State require that all vacant structures and premises shall be maintained in clean, safe, secure and sanitary conditions so as not to cause a blighting problem or adversely affect the public health or safety and all nuisances abated, AND

WHEREAS, the Town of Cheektowaga has received notification of an unsafe structure and premises located at 81 Saint Felix Avenue, Cheektowaga, New York SBL# 113.56-2-5 that is a danger to the safety of others, and records kept by the Assessors Office identify Richard Dycha and Helen T. Dycha, 57 Jones, Buffalo, New York 14206, as the owner AND

WHEREAS, an inspection of such premises was conducted at 81 Saint Felix Avenue, by the Housing and Neighborhood Preservation Office, AND

WHEREAS, such inspection found the premises to be deteriorated, vacant, a hazard, and a danger to the safety and well being of others, AND

WHEREAS, the Town of Cheektowaga Housing and Neighborhood Preservation Office properly notified the property owner in accordance with the Town of Cheektowaga Law for the Administration and Enforcement of the Codes of New York State, and the owner failed to take actions to safeguard the premises, AND

WHEREAS, these conditions require the Town of Cheektowaga Housing and Neighborhood Preservation Office to take immediate steps to safeguard the premises to protect the health and safety of others and abate all nuisances, NOW, THEREFORE BE IT

RESOLVED, that pursuant to Section 70-7A.(5) and Section 70-8 of the Town of Cheektowaga Law for the Administration and Enforcement of the Codes of New York State that the vacant structure premises be safeguarded and all nuisances abated; and all costs incurred be assessed against the property hereinbefore described.

RESULT:	ADOPTED [UNANIMOUS]
MOVER:	Charles Markel, Councilmember
SECONDER:	Mary Holtz, Supervisor
AYES:	Holtz, Rogowski, Markel, Kaminski, Wozniak, Benczkowski, Meyers



29. RESOLUTION 2014-213

Unsafe-Unsecured/67 A-D Windwood Court

Sponsored By: Councilmember Markel, Supervisor Holtz

WHEREAS, Town of Cheektowaga Law for the Administration and Enforcement of the Codes of New York State; and the Property Maintenance Code of New York State require that all vacant structures and premises shall be maintained in clean, safe, secure and sanitary conditions so as not to cause a blighting problem or adversely affect the public health or safety and all nuisances abated, AND

WHEREAS, the Town of Cheektowaga has received notification of an unsafe structure and premises located at 67 A-D Windwood Court, Cheektowaga, New York SBL# 91.14-2-21 that is a danger to the safety of others, and records kept by the Assessors Office identify Fred Leo and Wife, 50 Constitution Avenue, West Seneca, New York 14224, as the owner AND

WHEREAS, an inspection of such premises was conducted at 67 A-D Windwood Court, by the Housing and Neighborhood Preservation Office, AND

WHEREAS, such inspection found the premises to be deteriorated, vacant, a hazard, and a danger to the safety and well being of others, AND

WHEREAS, the Town of Cheektowaga Housing and Neighborhood Preservation Office properly notified the property owner in accordance with the Town of Cheektowaga Law for the Administration and Enforcement of the Codes of New York State, and the owner failed to take actions to safeguard the premises, AND

WHEREAS, these conditions require the Town of Cheektowaga Housing and Neighborhood Preservation Office to take immediate steps to safeguard the premises to protect the health and safety of others and abate all nuisances, NOW, THEREFORE BE IT

RESOLVED, that pursuant to Section 70-7A.(5) and Section 70-8 of the Town of Cheektowaga Law for the Administration and Enforcement of the Codes of New York State that the vacant structure premises be safeguarded and all nuisances abated; and all costs incurred be assessed against the property hereinbefore described.

RESULT:	ADOPTED [UNANIMOUS]
MOVER:	Charles Markel, Councilmember
SECONDER:	Mary Holtz, Supervisor
AYES:	Holtz, Rogowski, Markel, Kaminski, Wozniak, Benczkowski, Meyers



30. RESOLUTION 2014-214

Require Assistant Chief of Police to File Financial Disclosure Statement

Sponsored By: Supervisor Holtz, Councilmember Markel

WHEREAS, the Code of Ethics of the Town of Cheektowaga (Chapter 18 of the Town Code) provides, in part, that certain Town employees must annually file a Financial Disclosure Statement with the Town Board of Ethics, and

WHEREAS, by resolution dated April 4, 2011, the Town Board listed certain individuals who must file this Financial Disclosure Statement, and

WHEREAS, by resolution dated February 3, 2014, this Town Board filled a formerly vacant position of Assistant Chief of Police, and

WHEREAS, this Board feels that the Assistant Chief of Police should be required to annually file a Financial Disclosure Statement with the Town Board of Ethics, NOW, THEREFORE, BE IT

RESOLVED, that, effective immediately, the employee with the job title of Assistant Chief of Police be and hereby is required to annually file a Financial Disclosure Statement with the Town of Cheektowaga Board of Ethics.

RESULT:	ADOPTED [UNANIMOUS]
MOVER:	Mary Holtz, Supervisor
SECONDER:	Charles Markel, Councilmember
AYES:	Holtz, Rogowski, Markel, Kaminski, Wozniak, Benczkowski, Meyers



31. RESOLUTION 2014-215

Hiring/Termination of Part Time/Seasonal Employees

Sponsored By: Councilmember Kaminski, Supervisor Holtz

BE IT RESOLVED, that the following individuals be and hereby are hired as **SEASONAL EMPLOYEES**, not to exceed five (5) months in a calendar year, in the various departments listed and in compliance with Civil Service Laws and Regulations as well as the provisions of the Town's collective bargaining agreement between the Town of Cheektowaga and the Town of Cheektowaga Employees Association:

SANITATION DEPARTMENT Laborer \$9.00/hour effective 3/18/14
Michael J. Cristina, Cheektowaga, New York
Mark P. Mez, Cheektowaga, New York

FACILITIES DEPARTMENT (Parks Division) Laborer \$8.25/hour effective 4/26/14
Michael P. Tomczak, Cheektowaga, New York

FACILITIES DEPARTMENT (Parks Division) Laborer \$8.75/hour effective 4/27/14
Kyle J. Lackie, Cheektowaga, New York

FACILITIES DEPARTMENT (Parks Division) Laborer \$8.50/hour effective 5/20/14
Ryan J. Kowal, Cheektowaga, New York

BE IT RESOLVED, that the following individuals be and hereby are hired as **PART-TIME EMPLOYEES** in the departments listed, not to exceed nineteen (19) hours on a weekly basis, in compliance with Civil Service Laws and Regulations as well as the provisions of the Town's collective bargaining agreement between the Town of Cheektowaga and the Town of Cheektowaga Employees Association:

CENTRAL RECORDS MANAGEMENT Senior Clerk Typist (Grant/Temporary) \$15.00/hour effective 3/26/14
Maria A. Ross, Cheektowaga, New York

POLICE DEPARTMENT Police Attendant \$15.00/hour effective 4/7/14
Christina E. Moore, Depew, New York

CENTRAL RECORDS MANAGEMENT Clerk \$9.00/hour effective 4/7/14
Irene Kmiotek, Depew, New York

FACILITIES DEPARTMENT (Parks Division) Laborer \$8.50/hour effective 4/14/14
John E. Gluszek, Sloan, New York

BE IT RESOLVED, that the following seasonal and/or part-time employees be and hereby are terminated as listed:

POLICE DEPARTMENT
Melanie A. Dingeldej effective 3/14/14
Emily Wachowski effective 2/24/14

SANITATION DEPARTMENT
Andrew P. Babcock effective 3/15/14
Gregory L. Merritt effective 3/15/14

BE IT RESOLVED, that the following are amended as follows:

POLICE DEPARTMENT Police Attendant \$15.00/hour effective 3/4/14
Melanie A. Dingeldey, Sloan, New York

CENTRAL RECORDS MANAGEMENT from Senior Clerk Typist (Seasonal/Grant) to Senior Clerk Typist (Part Time/Grant) \$15.00/hour effective 4/1/14
Carol Brunner, Cheektowaga, New York

Motion by Councilmember Markel; Seconded by Councilmember Rogowski to waive the reading of names for this resolution. Motion Carried.

RESULT: ADOPTED [UNANIMOUS]
MOVER: Gerald Kaminski, Councilmember
SECONDER: Mary Holtz, Supervisor
AYES: Holtz, Rogowski, Markel, Kaminski, Wozniak, Benczkowski, Meyers



32. RESOLUTION 2014-216

Creation of Two (2) Assessment Clerk Positions

Sponsored By: Councilmember Kaminski, Supervisor Holtz

BE IT RESOLVED, that this Town Board hereby create two Assessment Clerk positions pursuant to Civil Service Laws and Rules effective April 8, 2014.

RESULT: WITHDRAWN



33. RESOLUTION 2014-217

Creation of Assistant Field Assessor Position

Sponsored By: Councilmember Kaminski, Supervisor Holtz

BE IT RESOLVED, that this Town Board hereby create an Assistant Field Assessor position pursuant to Civil Service Laws and Rules effective April 8, 2014.

RESULT:	WITHDRAWN
----------------	------------------



34. RESOLUTION 2014-218

Appointment of Sewer Maintenance Worker (Temporary/Saturnino J. Arvelo, Jr.)

Sponsored By: Councilmember Kaminski, Supervisor Holtz

WHEREAS, a temporary vacancy exists in the title of Sewer Maintenance Worker in the Sewer Maintenance Department; AND

WHEREAS, notice of said vacancy has been posted in accordance with the provisions of the Town's collective bargaining agreement with the Town of Cheektowaga Employees Association; AND

WHEREAS, Saturnino J. Arvelo, Jr., currently employed as a Maintenance Worker I in the Facilities Department, bid on said vacancy and meets the qualifications for appointment; NOW, THEREFORE, BE IT

RESOLVED, that Saturnino J. Arvelo, Jr., of Depew, New York, be and hereby is appointed to the temporary position of Sewer Maintenance Worker in the Sewer Maintenance Department in accordance with the terms and conditions of the Town's collective bargaining agreement with the Town of Cheektowaga Employees Association effective April 8, 2014.

RESULT:	ADOPTED [UNANIMOUS]
MOVER:	Gerald Kaminski, Councilmember
SECONDER:	Mary Holtz, Supervisor
AYES:	Holtz, Rogowski, Markel, Kaminski, Wozniak, Benczkowski, Meyers



35. RESOLUTION 2014-219

Travel Authorization (Police Department)/Police Chief David Zack, Captain Michael Isbrandt and Captain Michael Sliwinski

Sponsored By: Councilmember Benczkowski, Councilmember Kaminski

WHEREAS, the PERF National Summit on Illegal Drugs is being held April 16, 2014 in Washington, D.C; AND

WHEREAS, Police Chief David Zack, Captain Michael Isbrandt and Captain Michael Sliwinski have been recommended to attend said summit; AND

WHEREAS, a request for travel authorization along with the proper paperwork has been submitted in a timely manner; AND

WHEREAS, the total cost to the Town shall not exceed \$1,986; AND

WHEREAS, these expenses have been budgeted by the Department; NOW,
THEREFORE, BE IT

RESOLVED, that Police Chief David Zack, Captain Michael Isbrandt and Captain Michael Sliwinski be and hereby are authorized to attend the PERF National Summit on Illegal Drugs being held April 16, 2014 in Washington, D.C.

RESULT:	ADOPTED [UNANIMOUS]
MOVER:	Diane Benczkowski, Councilmember
SECONDER:	Gerald Kaminski, Councilmember
AYES:	Holtz, Rogowski, Markel, Kaminski, Wozniak, Benczkowski, Meyers



36. RESOLUTION 2014-220

Travel Authorization (Police Department)/Police Officers John Duskocz and John Jones

Sponsored By: Councilmember Benczkowski, Councilmember Kaminski

WHEREAS, the 2014 Annual K-9 Seminar is being held May 4 through May 8, 2014 in Penn Yan, New York; AND

WHEREAS, Police Officers John Duskocz and John Jones have been recommended to attend said seminar; AND

WHEREAS, Police Chief David Zack has submitted a request for travel authorization along with the proper paperwork in a timely manner; AND

WHEREAS, the total cost to the Town shall not exceed \$1,255; AND

WHEREAS, these expenses have been budgeted by the Department; NOW, THEREFORE, BE IT

RESOLVED, that Police Officers John Duskocz and John Jones be and hereby are authorized to attend the 2014 Annual K-9 Seminar being held May 4 through May 8, 2014 in Penn Yan, New York.

RESULT:	ADOPTED [UNANIMOUS]
MOVER:	Diane Benczkowski, Councilmember
SECONDER:	Gerald Kaminski, Councilmember
AYES:	Holtz, Rogowski, Markel, Kaminski, Wozniak, Benczkowski, Meyers



37. RESOLUTION 2014-221

Travel Authorization (Police Department)/Sergeant Lawrence Bauer and Police Officer Jacob Gawronski

Sponsored By: Councilmember Benczkowski, Councilmember Kaminski

WHEREAS, the Tactical Shotgun Instructor Course is being held May 5 through May 9, 2014 in Angola, New York; AND

WHEREAS, Sergeant Lawrence Bauer and Police Officer Jacob Gawronski have been recommended to attend said course; AND

WHEREAS, Police Chief David Zack has submitted a request for travel authorization along with the proper paperwork in a timely manner; AND

WHEREAS, the total cost to the Town shall not exceed \$1,320; AND

WHEREAS, these expenses have been budgeted by the Department; NOW, THEREFORE, BE IT

RESOLVED, that Sergeant Lawrence Bauer and Police Officer Jacob Gawronski be and hereby are authorized to attend the Tactical Shotgun Instructor Course being held May 5 through May 9, 2014 in Angola, New York.

RESULT:	ADOPTED [UNANIMOUS]
MOVER:	Diane Benczkowski, Councilmember
SECONDER:	Gerald Kaminski, Councilmember
AYES:	Holtz, Rogowski, Markel, Kaminski, Wozniak, Benczkowski, Meyers

V. Communications

A. Departmental Communications

1. **Supervisor's Statement of Funds - January 2014**
2. **Minutes: Cheektowaga Traffic Safety Commission - February 18, 2014**
3. **Minutes: Town Environmental Advisory Committee - March 5, 2014**
4. **Minutes: Cheektowaga Planning Board - March 13, 2014**
5. **Minutes: Cheektowaga Traffic Safety Commission - March 18, 2014**

B. General Communications

1. **Summons & Complaint: Nationstar Mortgage vs. Margaret Gardinier, Town of Cheektowaga & Etal Premises: 598 Aero Drive**
2. **Notice of Claim: Allstate Insurance Co. a/s/o Mary Watson vs. Town of Cheektowaga**
3. **Notice of Claim: Sharon Hearon vs. Town of Cheektowaga**
4. **Notice of Claim: Stacey Janczak vs. Town of Cheektowaga**
5. **Notice of Claim: Justin Leidolph vs. Town of Cheektowaga**
6. **Notice of Claim: Gary Mangine vs. Town of Cheektowaga**

VI. Comments

A. Supervisor's Comments

B. Councilmember's Comments

C. Public Comments

VII. Enter into Executive Session

1. **Motion To:** discuss Personnel Matters

RESULT:	ADOPTED [UNANIMOUS]
MOVER:	Mary Holtz, Supervisor
SECONDER:	Gerald Kaminski, Councilmember
AYES:	Holtz, Rogowski, Markel, Kaminski, Wozniak, Benczkowski, Meyers

VIII. Exit Executive Session

1. **Motion To:** return to meeting.

RESULT:	ADOPTED [UNANIMOUS]
MOVER:	Mary Holtz, Supervisor
SECONDER:	Charles Markel, Councilmember
AYES:	Holtz, Rogowski, Markel, Kaminski, Wozniak, Benczkowski, Meyers

IX. Suspension of Rules



1. RESOLUTION 2014-222

Prefer Disciplinary Charges Against Police Officer and Appoint Hearing Officer

Sponsored By: Benczkowski, Kaminski, Holtz, Rogowski, Markel, Wozniak, Meyers

WHEREAS, Cheektowaga Chief of Police David J. Zack has recommended disciplinary charges against a certain Town of Cheektowaga Police Officer (the "Officer"); and

WHEREAS, a Notice of Hearing ("Notice") and accompanying Charges and Specifications ("Charges") have been prepared for service upon the Officer; NOW, THEREFORE, BE IT

RESOLVED that the Cheektowaga Town Board hereby issues the prepared Notice and prefers the accompanying Charges, for service upon the Officer at the Officer's address indicated therein; and BE IT FURTHER

RESOLVED that, pursuant to Section 75 of the New York State Civil Service Law and Section 155 of the New York State Town Law, Deputy Town Attorney Jeffrey L. Whiting (the "Deputy Town Attorney") is hereby appointed to act as Hearing Officer to hear charges and report and recommend to the Cheektowaga Town Board proposed disciplinary action, upon the Charges preferred against the Officer; and BE IT FURTHER

RESOLVED that upon service of Notice of Hearing and Charges and Specifications, the Officer shall be suspended with pay pending the hearing and determination of charges; and BE IT FURTHER

RESOLVED that the Hearing to be conducted by the Deputy Town Attorney shall be bifurcated into two separate phases; and BE IT FURTHER

RESOLVED that, pursuant to the first phase of the Hearing, the Deputy Town Attorney shall take testimony to determine only whether the Officer is guilty of any of the Charges preferred; and BE IT FURTHER

RESOLVED that, if and only if the Officer is found guilty of one or more of the Charges preferred, the Hearing shall proceed to a second phase, pursuant to which the Deputy Town Attorney shall take testimony to determine a recommended punishment for the Officer.

RESULT:	ADOPTED [UNANIMOUS]
MOVER:	Diane Benczkowski, Councilmember
SECONDER:	Gerald Kaminski, Councilmember
AYES:	Holtz, Rogowski, Markel, Kaminski, Wozniak, Benczkowski, Meyers

X. Adjournment

Moment of Silence for Stanley Blake, a member of the Town's Veteran's Committee.

This meeting is adjourned at 8:10 PM

Alice Magierski, Town Clerk

**Town of Cheektowaga
Engineering Department**

Bid opening for Manhole / Catch Basin Frames and Covers
Wednesday April 2, 2014 @ 11:00 am

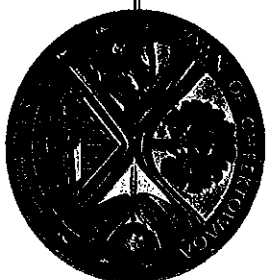

Contractor	Bid Item I Self sealing MH's 25 sets	Bid Item II Vented MH's 25 sets	Bid Item III Alternate Catch Basin US / N. America 250 sets	Bid Item IV Alternate Catch Basin Non US / N. America 250 sets
Neenah Foundry Company	\$6,200.00	\$7,175.00	\$46,250.00	No Bid
HD Supply	\$5,947.00	\$5,631.25	\$91,575.00	\$842,102.50
Vellano Companies	\$5,875.00	\$5,475.00	\$91,500.00	\$40,750.00
K & S Supply	No Bid	No Bid	No Bid	\$40,000.00



Town of Cheektowaga

Regular Meeting

~ Minutes ~

3301 Broadway
Cheektowaga, NY 14227
<http://www.town.cheektowaga.ny.us>

Alice Magierski
716-686-3400

Monday, April 21, 2014

6:45 PM

Council Chambers

I. Call to Order

Attendee Name	Organization	Title	Status	Arrived
Mary Holtz	Town of Cheektowaga	Supervisor	Absent	
James P. Rogowski	Town of Cheektowaga	Councilmember	Present	
Gerald Kaminski	Town of Cheektowaga	Councilmember	Present	
Angela M. Wozniak	Town of Cheektowaga	Councilmember	Present	
Diane Benczkowski	Town of Cheektowaga	Councilmember	Present	
Timothy J. Meyers	Town of Cheektowaga	Councilmember	Present	

2. Additional Attendees

Thomas Adamczak, Supervising Building and Plumbing Inspector
 Brian Krause, Director of Finance and Administration
 William Pugh, Town Engineer
 Kevin Schenk, Town Attorney
 Mark Wegner, Highway Superintendent

II. Public Comment Period

III. Public Hearings

1. 432 Dingens Street Rezoning Request

COMMENTS - Current Meeting:

This being the time and place advertised for a Public Hearing, the Supervisor directed the Town Clerk to present that such notice has been duly published and posted; upon the order of the Supervisor such proof was duly filed.

The Supervisor announced that the Town Board would hear all persons interested in the subject of the hearing. Comments were heard, after which the Supervisor declared the hearing closed, decision was reserved.

RESULT: CLOSED [UNANIMOUS]
MOVER: James P. Rogowski, Councilmember
SECONDER: Gerald Kaminski, Councilmember
AYES: Rogowski, Kaminski, Wozniak, Benczkowski, Meyers
ABSENT: Mary Holtz

2. Demolition of 129 David Avenue

COMMENTS - Current Meeting:

This being the time and place advertised for a Public Hearing, the Supervisor directed the Town Clerk to present that such notice has been duly published and posted; upon the order of the Supervisor such proof was duly filed.

The Supervisor announced that the Town Board would hear all persons interested in the subject of the hearing. Comments were heard, after which the Supervisor declared the hearing closed, decision was reserved.

RESULT: **CLOSED [UNANIMOUS]**
MOVER: James P. Rogowski, Councilmember
SECONDER: Gerald Kaminski, Councilmember
AYES: Rogowski, Kaminski, Wozniak, Benczkowski, Meyers
ABSENT: Mary Holtz

IV. Resolutions



1. RESOLUTION 2014-223

Transfer of Funds-2013

Sponsored By: Councilmember Kaminski, Councilmember Rogowski

BE IT RESOLVED, that the following transfer is hereby approved and made part hereof;

GENERAL

FROM:	100.9501.9211	Bond Interest	\$388,902.00
	100.9499.1902	Overtime	9,218.00
	100.9010.8111	Police Retirement	1,364,296.00
	100.9010.8143	Retiree Medical Insurance	732,089.00
	100.9010.8975	Retirement Buyout	409,552.00
TO:	100.9501.9131	Bond Principal	\$63,896.00
	100.9499.1901	Regular Payroll	1,168.00
	100.9499.1971	Part Time Payroll	8,493.00
	100.9902.9703	Transfer to Risk Retention	980,000.00
	100.9950.8729	Transfer to Capital	1,850,500.00

RISK RETENTION

FROM:	101.1932.4703	General Liability Expense	\$175,709.00
	101.1933.4703	Health Claims Expense	136,381.00
	101.1936.4703	Catastrophe Expense	100,000.00
	101.1710.4525	Work. Comp. Assessments Admin.	41,734.00
TO:	101.1722.4519	W/C Excess Insurance	\$8,998.00
	101.1930.4703	Workers Comp. Expenses	429,996.00
	101.1937.4703	Dental/Vision Expenses	14,830.00

SEWER

FROM:	255.8125.4353	Erie County Sewer District#4	\$175,736.00
	255.8125.9101	Bond Principal	149,972.00
TO:	255.8125.9990	Transfer to Capital	\$325,708.00

HIGHWAY

FROM:	300.5141.1734	Labor Allocated	\$88,168.74
	300.9501.9211	Bond Interest	504,505.00
	300.1910.1120	Sales Tax Revenue	305,495.00
TO:	300.5140.1701	Labor General	\$88,168.74
	300.9950.8000	Transfer to Capital	810,000.00

DRAINAGE

FROM:	400.8140.9201	Bond Interest	\$22,242.00
TO:	400.8140.9101	Bond Principal	\$22,242.00

RESULT:	ADOPTED [UNANIMOUS]
MOVER:	Gerald Kaminski, Councilmember
SECONDER:	James P. Rogowski, Councilmember
AYES:	Rogowski, Kaminski, Wozniak, Benczkowski, Meyers
ABSENT:	Mary Holtz



2. RESOLUTION 2014-224

Transfer of Funds-2014

Sponsored By: Councilmember Kaminski, Councilmember Rogowski

BE IT RESOLVED, that the following transfer is hereby approved and made part hereof;

CDBG

FROM:	700.1010.2200	Acquisition-IDIS #973	\$3,248.72
	700.1012.0603	Environmental Hazard TestingIDIS#1096	6.28
TO:	700.1013.0600	Housing Rehab-Single Family	\$3,255.00

RESULT:	ADOPTED [UNANIMOUS]
MOVER:	Gerald Kaminski, Councilmember
SECONDER:	James P. Rogowski, Councilmember
AYES:	Rogowski, Kaminski, Wozniak, Benczkowski, Meyers
ABSENT:	Mary Holtz



3. RESOLUTION 2014-225

Warrant

Sponsored By: Councilmember Kaminski, Councilmember Rogowski

BE IT RESOLVED, that the following Vouchers & Warrants submitted to the Town of Cheektowaga prior to April 21, 2014 are hereby approved and made part hereof;

GENERAL FUND	\$3,507,729.23
RISK RETENTION FUND	991,669.51
NYS HOME PROGRAM	
DEBT	
HUD HOUSING REHABILITATION FUND	81.20
SPECIAL DISTRICTS FUND	1,446,864.05
HIGHWAY FUND	526,412.23
CAPITAL FUND	21,856.55
TRUST & AGENCY FUND	32,029.33
HUD CDBG FUND	1,156.00
PART TOWN FUND	2,124.58
NYS AFFORDABLE HOUSING	115,044.86
	<hr/>
	\$6,644,967.54

RESULT:	ADOPTED [UNANIMOUS]
MOVER:	Gerald Kaminski, Councilmember
SECONDER:	James P. Rogowski, Councilmember
AYES:	Rogowski, Kaminski, Wozniak, Benczkowski, Meyers
ABSENT:	Mary Holtz



4. RESOLUTION 2014-226

Amend Award of Bid Resolution for Cold Milling of Various Town Highways (Bid #2014-12)

Sponsored By: Councilmember Kaminski, Councilmember Rogowski

WHEREAS, by resolution adopted April 7, 2014 (2014-187), this Town Board awarded a contract for the Cold Milling of Various Town Highways within the Town of Cheektowaga (Bid 2014-12), AND

WHEREAS, the name and address of the entity to whom the contract was awarded was inadvertently stated as "Swank Associated Companies Inc., 200 Hunt Valley Road", AND

WHEREAS, the correct corporate name and address of the entity to whom the contract was awarded is "Swank Construction Company LLC, 632 Hunt Valley Circle" as shown on the bid form submitted by them, NOW, THEREFORE, BE IT

RESOLVED, that the first "RESOLVED" paragraph of Resolution 2014-187 shall be amended to read as follows:

"RESOLVED, that the contract for the Cold Milling of Various Town Highways in the Town of Cheektowaga for the year of 2014 be awarded to:

Swank Construction Company LLC
632 Hunt Valley Circle
New Kensington, PA 15068

for the bid price of \$129,250.00, said being the lowest bid meeting the requirements of the specifications."

RESULT:	ADOPTED [UNANIMOUS]
MOVER:	Gerald Kaminski, Councilmember
SECONDER:	James P. Rogowski, Councilmember
AYES:	Rogowski, Kaminski, Wozniak, Benczkowski, Meyers
ABSENT:	Mary Holtz



5. RESOLUTION 2014-227

Award of Bid - Topsoil (Bid # 2014-18)

Sponsored By: Councilmember Kaminski, Councilmember Meyers

WHEREAS, as a result of advertisement, bids were received on April 16, 2014 for the purchase of Topsoil for the 2014 calendar year for use by the Cheektowaga Highway Department and various other departments in the Town, AND

WHEREAS, said bids were referred to the Engineering Department for analysis and tabulation, NOW, THEREFORE, BE IT

RESOLVED, that the bid for the purchase of Topsoil be awarded to Bengert Greenhouses for their submission of the lowest bid meeting the requirements of the specifications, AND, BE IT FURTHER

RESOLVED, that the bid for the purchase of Topsoil be and hereby is awarded to:

Bengert Greenhouses
230 French Road
West Seneca, New York 14224

for the bid price of:

Item 1	Unscreened/Delivered	\$13.69 per 500 C.Y.
Item 1-A	Unscreened/Pick-Up	\$13.00 per 500 C.Y.
Item 2	Screened/Delivered	\$17.69 per 2,000 C.Y.
Item 2-A	Screened/Pick-Up	\$16.30 per 2,000 C.Y.

AND, BE IT FURTHER

RESOLVED, that payment for said Topsoil shall be chargeable to the appropriate departmental budget line item.

RESULT:	ADOPTED [UNANIMOUS]
MOVER:	Gerald Kaminski, Councilmember
SECONDER:	Timothy J. Meyers, Councilmember
AYES:	Rogowski, Kaminski, Wozniak, Benczkowski, Meyers
ABSENT:	Mary Holtz



6. RESOLUTION 2014-228

Award of Bid - Sidewalk Replacement/ADA Ramp Installation (Bid #2014-19)

Sponsored By: Councilmember Kaminski, Councilmember Meyers

WHEREAS, as a result of advertisement, bids were received on April 16, 2014 for the replacement of sidewalks at various locations within the Town of Cheektowaga for the 2014 calendar year, AND

WHEREAS, said bids were referred to the Engineering Department for analysis and tabulation, NOW, THEREFORE, BE IT

RESOLVED, that the contract for the replacement of sidewalks be awarded to Yarussi Construction, Inc. For their submission of the lowest bid meeting the requirements of the specifications, AND, BE IT FURTHER

RESOLVED, that the bid for the replacement of sidewalks be and hereby is awarded to:

Yarussi Construction, Inc.
5650 Simmons Avenue
Niagara Falls, New York 14304

for the total bid price of \$575,200.00 for Bid Items 1 thru 3 for the year of 2014, AND, BE IT FURTHER

RESOLVED, that payment for said sidewalks shall be chargeable to the appropriate departmental budget line item.

RESULT:	TABLED [UNANIMOUS] Next: 5/5/2014 6:45 PM
MOVER:	Angela M. Wozniak, Councilmember
SECONDER:	Diane Benczkowski, Councilmember
AYES:	Rogowski, Kaminski, Wozniak, Benczkowski, Meyers
ABSENT:	Mary Holtz



7. RESOLUTION 2014-229

Award of Bid - Equipment & Operators for Public Works Projects (Bid #2014-20)

Sponsored By: Councilmember Kaminski, Councilmember Benczkowski

WHEREAS, as a result of advertisement, bids were received on April 16, 2014 for the furnishing of Equipment and Operators for Public Works Projects in the Town of Cheektowaga, AND

WHEREAS, said bids were referred to the Engineering Department for analysis and tabulation, NOW, THEREFORE, BE IT

RESOLVED, that the contract for the furnishing of Equipment and Operators for Public Works Projects in the Town of Cheektowaga for the period of April 21, 2014 to April 20, 2015 be awarded to Nichols, Long & Moore Construction Corporation, 149 Gunnvile Road, Lancaster, New York 14086 for submission of the lowest bid meeting the specifications as per the unit prices of:

April 21, 2014 - April 20, 2015
Per 8 Hour Day

Item 1	Tandem Dump Truck	\$80.00
Item 2	Hydraulic Rubber Tire Backhoe	\$76.00
Item 3	Pavement Saw Cutting Machine	\$100.00
Item 4	Hydraulic Crawler Backhoe (JD-160)	\$110.50
Item 5	Hydraulic Crawler Backhoe (JD-290)	\$95.00
Item 6	Bulldozer	\$90.00
Item 7	Front End Wheel Loader	\$108.00
Item 8	1.5 Ton Vibratory Blacktop Roller	\$75.00
Item 9	Hydraulic Crawler Backhoe W/Hammer	\$75.00
Item 10	Smooth Drum Dirt Roller	\$75.00
Item 11	Skilled Laborer	\$90.00
Item 12	Equipment Truck	\$ 6.00
Item 13	8' x 10' Trench Shield	\$ 1.00
Item 14	Air Compressor W/Hammers	\$ 7.50
Item 15	Sewer Line Repair Crew	\$342.00
Item 16	New Sewer Line Installation Crew	\$484.50

AND, BE IT FURTHER

RESOLVED, that payment for work performed under this contract shall be chargeable to the appropriate departmental budgeted line item.

RESULT: **TABLED [UNANIMOUS] Next: 5/5/2014 6:45 PM**
MOVER: Angela M. Wozniak, Councilmember
SECONDER: Diane Benczkowski, Councilmember
AYES: Rogowski, Kaminski, Wozniak, Benczkowski, Meyers
ABSENT: Mary Holtz



8. RESOLUTION 2014-230

Award Contract for Grass Cutting of Town-Owned Properties (2014)

Sponsored By: Councilmember Kaminski, Councilmember Benczkowski

WHEREAS, the Town of Cheektowaga owns (twelve) 12± residential properties on which the grass needs to be regularly cut; and

WHEREAS, a Request for Proposals ("RFP") was issued to have private contractors perform these services; and

WHEREAS, proposals were received from four (4) firms; and

WHEREAS, the proposal having the lowest cost to the Town was submitted by Grabber & Sons Landscaping & Nursery; NOW, THEREFORE, BE IT

RESOLVED, that the contract for lawn cutting and trimming services for the twelve (12) Town properties shown on the list in the RFP be and hereby is awarded to Grabber & Sons Landscaping & Nursery, 3242 Harlem Road, Cheektowaga, 14225, for lawn cutting and trimming for 12 properties for \$420.00 bi-weekly; and BE IT FURTHER

RESOLVED, that the Supervisor be and hereby is authorized and directed to execute a contract and any and all other documents to effectuate terms of a contract for these services, subject to approval of the Town Attorney; and BE IT FURTHER

RESOLVED, that the fees for said services shall be appropriated from the following Town budget line items:

Account #800-3620-4561

Account #700-1007-0606

RESULT:	ADOPTED [UNANIMOUS]
MOVER:	Gerald Kaminski, Councilmember
SECONDER:	Diane Benczkowski, Councilmember
AYES:	Rogowski, Kaminski, Wozniak, Benczkowski, Meyers
ABSENT:	Mary Holtz



9. RESOLUTION 2014-231

Negative SEQR Declaration - Part of SBL No. 114.04-5-27.1 North of 4968 Transit Road - Goodyear Tire

Sponsored By: Councilmember Meyers, Councilmember Wozniak

WHEREAS, pursuant to the Environmental Impact Review Ordinance of the Town of Cheektowaga, the Environmental Advisory Committee ("EAC") reviews various applications for site plans, rezonings, special permits, etc. And renders its recommendation concerning the environmental significance of such application, AND

WHEREAS, the Town Board, pursuant to the Environmental Impact Review Ordinance of the Town of Cheektowaga, is designated the Lead Agency in most instances, AND

WHEREAS, since the Town Board is the Lead Agency, it must affirm, modify or reject any recommendations submitted to it by the Advisory Committee, AND

WHEREAS, an application was submitted by 4986 Transit Road, LLC for the rezoning of a portion of SBL No. 114.04-5-27.1 from NS- Neighborhood Services to MS- Motor Service for the construction of a 6,258 s.f. motor service facility, AND

WHEREAS, the subject property contains an isolated wetland deemed not to be regulated pursuant to section 404 of the Clean Water Act, and as confirmed by the attached letter of no jurisdiction from the US Army Corps. of Engineers dated April 18, 2012, AND

WHEREAS, a noise assessment was prepared by Aurora Acoustical Consultants, Inc., in which it was determined that the proposed auto repair facility would not exceed the maximum allowable decible limits established by the town's Noise Ordinance, AND

WHEREAS, the Town of Cheektowaga Planning Board recommended approval of the rezoning request and site plan at their meeting of February 13, 2014, AND

WHEREAS, the Town of Cheektowaga Traffic Safety Commission has reviewed the subject project and is recommending its approval, AND

WHEREAS, the Environmental Advisory Committee has recommended a determination of non-significance, AND

WHEREAS, this Town Board has reviewed the application submitted and the recommendations made by the Environmental Advisory Committee, the Planning Board, and the Traffic Safety Commission NOW, THEREFORE, BE IT

RESOLVED, that this Town Board determines that the project will not have a significant effect on the environment and therefore issues a Negative Declaration for purposes of the State Environmental Quality Review Act (SEQRA).

RESULT: **ADOPTED [UNANIMOUS]**
MOVER: Timothy J. Meyers, Councilmember
SECONDER: Angela M. Wozniak, Councilmember
AYES: Rogowski, Kaminski, Wozniak, Benczkowski, Meyers
ABSENT: Mary Holtz



10. RESOLUTION 2014-232

Accept Site Plan- Part of SBL. No. 114.05-5-27.1 North of 4968 Transit Road - Goodyear Tire

Sponsored By: Councilmember Rogowski, Councilmember Wozniak

WHEREAS, pursuant to the Zoning Law of the Town of Cheektowaga, the Planning Board reviews various development review applications for site plans, rezonings, special permits and realty subdivisions and renders its recommendation concerning the compatibility of such application with the zoning regulations, the Town Master Plan and neighborhood character, AND

WHEREAS, the Town Board, pursuant to section 260-47.1C of the Zoning Law of the Town of Cheektowaga is vested with the authority to approve site plans and modify or reject any recommendation submitted to it by its advisory committees, AND

WHEREAS, 4968 Transit Road, LLC submitted a development review application for the rezoning of a portion of SBL No. 114.04-5-27.1 from NS- Neighborhood Services to MS- Motor Service, for the construction of a 6,258 s.f. auto repair facility, AND

WHEREAS, the Town of Cheektowaga Planning Board, reviewed and commented on the application at their meeting of February 13, 2014 and have recommended approval of the site plan and have reserved decision on the landscaping plan, NOW THEREFORE BE IT,

RESOLVED, that pursuant to Section 260-47-1 of the Code of the Town of Cheektowaga and Section 274-a of New York State Town Law that this Town Board approves the proposed site plan subject to:

1. The applicant removing the existing billboard signs on the entire premises.
2. The entire premises of SBL No. 114.05-5-27.1 will be limited to the single driveway along Transit Road as shown on the attached site plan.
3. The applicant providing a perpetual vehicular access easements allowing for the cross circulation of motor vehicles across the north property line and the southerly portion of the undeveloped portion of SBL No. 114.05-5-27.1 as shown on the attached site plan.
4. All proposed exterior lighting shall utilize dark sky compliant light fixtures.
5. The applicant submitting a landscaping plan along with a tree mitigation proposal to meet the requirements of section 229-5 (Replacement Trees) of the Town of Cheektowaga Town Code.
6. The Town Engineer review and approve the drainage/grading plan.
7. The store operator shall maintain bay doors closed, to minimize noise disturbances.

RESULT: **ADOPTED [UNANIMOUS]**
MOVER: James P. Rogowski, Councilmember
SECONDER: Angela M. Wozniak, Councilmember
AYES: Rogowski, Kaminski, Wozniak, Benczkowski, Meyers
ABSENT: Mary Holtz



11. RESOLUTION 2014-233

Approval of Rezoning of a Portion of 4968 Transit Road (Part of SBL No. 114.04-5-27.1)

Sponsored By: Councilmember Rogowski, Councilmember Benczkowski

WHEREAS, 4968 Transit Road, LLC petitioned for a rezoning from C-Retail Business District to MS-Motor Services District for property owned by it and identified as a portion of SBL No. 114.04-5-27.1, north of 4968 Transit Road, Cheektowaga, New York, which property is described in the attached legal description, for the construction of a 19,800 s.f. retail building and a 6,258 s.f. motor repair facility building, and

WHEREAS, a public hearing on such petition was held before this Town Board on the 19th day of February, 2014 at 6:45 P.M., after publication and service of the notices required by the provisions of the Code of the Town of Cheektowaga ("Zoning Law"), and the Town Law; and all interested parties were given an opportunity to be heard at such hearing, and

WHEREAS, the Cheektowaga Planning Board has reviewed such application and has recommended approval thereof, and

WHEREAS, this Town Board previously issued a Negative Declaration under SEQRA and the Town Environmental Impact Review Ordinance for this rezoning, NOW, THEREFORE, BE IT

RESOLVED, that the application of 4968 Transit Road, LLC for the rezoning from C-Retail Business District to MS-Motor Services District of the property described in the attached legal description for the construction of a 19,800 s.f. retail building and 6,258 s.f. motor vehicle repair facility be and the same is hereby approved, and BE IT FURTHER

RESOLVED, that any future additions to the development or site plan must be resubmitted to the Town Board to determine whether the addition is substantially in agreement with the intent of this rezoning and site plan approval, and BE IT FURTHER

RESOLVED, that the Zoning Map and Law of the Town Of Cheektowaga be amended in accordance with the above.

LEGAL DESCRIPTION

EXHIBIT A

ALL THAT TRACT OR PARCEL OF LAND, situate in the Town of Cheektowaga, County of Erie and State of New York, being part of Lot No, 46, Township 10, Range 7 of the Buffalo Creek Reservation, bounded and described as follows:

Commencing at the point of intersection of the south line of Strasmer Road (66 feet wide) with the west line of Transit Road (100 feet wide); running thence south along said west line of

Transit Road, 400 feet to the point or place of beginning, said point of beginning also being the southeast corner of lands conveyed to NY Chiropractic College by deed recorded in the Erie County Clerk's Office in Liber 10945 of Deeds at page 5613; thence south and continuing along said west line of Transit Road, a distance of 105.0 feet to a point, thence west 90 degrees, a distance of 383.0 feet along a line which is parallel to the south line of the aforementioned lands conveyed to the NY Chiropractic College to a point, thence north 90 degrees along the east line of lands conveyed to Ludwig Zellner and Grace, his wife, by deed recorded in the Erie County Clerk's Office in Liber 3243 , page 161 a distance of 105.0 feet to the southwest corner of lands conveyed to NY Chiropractic College aforementioned , then west 90 degrees a distance of 383.0 feet to the point of beginning, containing an area of 0.92+/- acres.

RESULT:	ADOPTED [UNANIMOUS]
MOVER:	James P. Rogowski, Councilmember
SECONDER:	Diane Benczkowski, Councilmember
AYES:	Rogowski, Kaminski, Wozniak, Benczkowski, Meyers
ABSENT:	Mary Holtz



12. RESOLUTION 2014-234

Call for a Public Hearing to Amend the Taxicabs Law

Sponsored By: Councilmember Benczkowski, Councilmember Kaminski

WHEREAS, Chapter 23 of the Code of the Town of Cheektowaga, entitled "Taxicabs" was adopted by the Town Board on October 21, 1985, and

WHEREAS, said law requires anyone who operates a taxicab or similar vehicle-for-hire to obtain a permit from the Town Clerk and to otherwise comply with the other provisions of said law, and

WHEREAS, the Town Clerk and Police Department have recommended that this law be repealed and that a new Taxicabs Law be enacted, and

WHEREAS, on November 18, 2013, a public hearing was held on proposed Local Law Intro No. 2013-4 of the Year 2013, entitled "A Local Law to Amend the Taxicabs Law", and

WHEREAS, after said public hearing, changes were made to said proposed local law, and

WHEREAS, the Petitions Committee has reviewed this revised draft law and has recommended approval of same, THEREFORE, BE IT

RESOLVED, that, in accordance with the provisions of the Town Law/Municipal Home Rule Law of the State of New York, a public hearing shall be held on the 5th day of May, 2014 at 6:45 P.M. at the Town Hall, 3301 Broadway, Cheektowaga, New York, at which hearing all interested parties will be given an opportunity to be heard and at which time and place it may be determined by the Town Board whether Local Law Intro No. 2014-2 of the Year 2014 entitled "A Local Law to Amend the Taxicabs Law" should be enacted, and BE IT FURTHER

RESOLVED, that the Town Clerk shall publish the attached Notice of Hearing in the CHEEKTOWAGA BEE, the official Town newspaper.



LEGAL NOTICE

NOTICE IS HEREBY GIVEN that a public hearing will be held by the Town Board of the Town of Cheektowaga, Erie County, New York at the Town Hall, 3301 Broadway, Cheektowaga, New York, on the 5th day of May, 2014 at 6:45 P.M. on said day for the purpose of considering the adoption of Local Law Intro No. 2014-2 of the Year 2014, entitled "A Local Law to Amend the Taxicabs Law". A summary of such Local Law is as follows:

LOCAL LAW INTRO NO. 2014-2 OF THE YEAR 2014**A LOCAL LAW TO AMEND THE TAXICABS LAW**

This local law would repeal the existing Taxicabs Law and replace it with a new Taxicabs Law which would generally require owners and drivers of taxicabs and/or liveries which operate on public highways located in the Town of Cheektowaga to obtain licenses from the Town Clerk and to pay the requisite fees for said licenses.

Procedures are established in the event of a denial of an owner's or driver's license.

Rules are established for the operation of taximeters in the taxicab/livery.

In addition, general rules are established for the operation of taxicabs/liveries within the corporate limits of the Town of Cheektowaga.

Violations of this law and punishable by fines established in said law.

A copy of the entire text of the proposed new "Taxicabs Law" is on file in the Town Clerk's Office, where same can be viewed during regular business hours.

BY ORDER OF THE TOWN BOARD OF THE TOWN OF CHEEKTOWAGA, ERIE
COUNTY

April 21, 2014

ALICE MAGIERSKI, Town Clerk

RESULT:	ADOPTED [UNANIMOUS]
MOVER:	Diane Benczkowski, Councilmember
SECONDER:	Gerald Kaminski, Councilmember
AYES:	Rogowski, Kaminski, Wozniak, Benczkowski, Meyers
ABSENT:	Mary Holtz



13. RESOLUTION 2014-235

Notice to Bidders for the Acceptance for Disposal of Yard Waste (Excepting Therefrom Highway Debris) Generated in and Collected by the Town of Cheektowaga for Calendar Years 2014-2018 (BID 2014-15 LAW)

Sponsored By: Councilmember Kaminski, Councilmember Rogowski

BE IT RESOLVED, that the Town Clerk is hereby directed to publish a Notice to Bidders for the Acceptance for Disposal of Yard Waste (Excepting Therefrom Highway Debris) Generated in and Collected by the Town of Cheektowaga for Calendar Years 2014-2018 (BID 2014-15 LAW), said notice to be published in the Cheektowaga Bee; and BE IT FURTHER

RESOLVED, that sealed bids will be received on Wednesday, April 30, 2014, at 11:00 A.M. at a public bid opening to be held in the Council Chambers in the Cheektowaga Town Hall.



NOTICE TO BIDDERS

Sealed proposals will be received by the Town Clerk of the Town of Cheektowaga on WEDNESDAY, APRIL 30, 2014, at 11:00 A.M. at the Cheektowaga Town Hall, 3301 Broadway, Cheektowaga, New York, for the Acceptance for Disposal of Yard Waste (*excepting therefrom highway debris*) Generated in and Collected by the Town of Cheektowaga for Calendar Years 2014-2018 (BID 2014-15 LAW).

Information for bidders and specifications may be obtained from the Town Clerk at her office in said Town. Proposals shall be submitted in a sealed envelope, plainly marked on the outside "Bid for Yard Waste Disposal" and submitted to the Town Clerk prior to bid opening.

The Town Board reserves the right to consider informal any bid not prepared and submitted in accordance with the provisions of the specification and contract documents, and may waive any informalities, make an award to other than the low bidder, or reject any or all bids should it be in the best interest of the Town.

BY ORDER OF THE TOWN BOARD OF THE TOWN OF CHEEKTOWAGA, ERIE COUNTY, NEW YORK.

Alice Magierski, Town Clerk

Dated: 21 April 2014

RESULT:	ADOPTED [UNANIMOUS]
MOVER:	Gerald Kaminski, Councilmember
SECONDER:	James P. Rogowski, Councilmember
AYES:	Rogowski, Kaminski, Wozniak, Benczkowski, Meyers
ABSENT:	Mary Holtz



14. RESOLUTION 2014-236

Notice to Bidders for Controlled Demolition with Asbestos in Place Of 129 David Avenue, Cheektowaga, N.Y. (Bid 2014-21 LAW)

Sponsored By: Councilmember Kaminski, Councilmember Rogowski

WHEREAS, it is in order that a bid be advertised for the Controlled Demolition with Asbestos in Place of the structures located at 129 David Avenue in the Town of Cheektowaga; and

WHEREAS, specifications for same have been prepared by the Town Attorney's Office; NOW, THEREFORE, BE IT

RESOLVED, that the Town Clerk be and hereby is directed to publish a Notice to Bidders for the Controlled Demolition with Asbestos in Place of the structures located at 129 David Avenue, Cheektowaga, New York (Bid 2014-21 LAW); and BE IT FURTHER

RESOLVED, that sealed bids will be received and opened by the Town Clerk at a public bid opening to be held in the Council Chambers at the Cheektowaga Town Hall, 3301 Broadway, Cheektowaga, New York, on Wednesday, May 7, 2014 at 11:00 A.M.



NOTICE TO BIDDERS

Sealed proposals will be received by the Town Clerk of the Town of Cheektowaga on WEDNESDAY, MAY 7, 2014, at 11:00 A.M. at the Cheektowaga Town Hall, 3301 Broadway, Cheektowaga, New York, for the Controlled Demolition with Asbestos in Place of structures located at 129 David Avenue in the Town of Cheektowaga, New York (Bid 2014-21 LAW).

Information for bidders and specifications may be obtained from the Town Clerk at her office in said Town.

The Town Board reserves the right to consider informal any bid not prepared and submitted in accordance with the provisions of the specification and contract documents, and may waive any informalities, make an award to other than the low bidder, or reject any or all bids should it be in the best interest of the Town.

BY ORDER OF THE TOWN BOARD OF THE TOWN OF CHEEKTOWAGA, ERIE COUNTY, NEW YORK.

Alice Magierski, Town Clerk

Dated: April 21, 2014

RESULT:	WITHDRAWN
----------------	------------------



15. RESOLUTION 2014-237

Authorize Town Clerk to Issue New/Renewal Vehicle Licenses

Sponsored By: Councilmember Wozniak, Councilmember Benczkowski

WHEREAS, on the 7th day of May, 1984, this Town Board adopted an Ambulance Ordinance. The EMS Board, which was created at that time, has completed a review and evaluation of new/renewal license applications for ambulances and has recommended that the Town Board license such ambulance(s), NOW, THEREFORE, BE IT

RESOLVED, that the Town Board, pursuant to Section A-5 of the Ambulance Ordinance accept the recommendations of the Emergency Medical Services Board, and approve the attached list of vehicles and, BE IT FURTHER

RESOLVED, that the Town Clerk is hereby authorized, directed and empowered to issue ambulance licenses to the applicants set forth below, providing such ambulance(s) so listed meet(s) the insurance requirements set forth in the Ambulance Ordinance.

<u>VEHICLE MAKE & YEAR</u>	<u>LICENSE NO.</u>	<u>CALL NO.</u>
Ford 2005	10209EV	502
International 1998	12910ET	503
GMC 2010	10211EV	559
Chevrolet2010	10210EV	558
Ford 2006	GBA7361	Medic-12
Chevrolet 2004	GAZ9431	Medic-11
Chevrolet 2005	DDG8519	Medic-10
Ford 2001	10602ET	588
Ford 1997	12662ET	584
Ford 1993	12667ET	577
Ford 2006	10613ET	575
Ford 2006	10614ET	574
Ford 2005	10627ET	573
Ford 2005	10628ET	571
Ford 2005	10629ET	570
Ford 1999	16755ET	564
Chevrolet 2013	10273EV	560
Chevrolet 2013	10272EV	557
Chevrolet 2013	10271EV	556
Chevrolet 2012	10270EV	555
Chevrolet 2012	10269EV	554
Ford 1999	10625ET	549
Ford 1999	10268EV	548
Ford 2003	10608ET	547
Ford 2003	10607ET	546
Ford 2000	10267EV	545
GMC 2008	10248EV	540
GMC 2012	10249EV	539
GMC 2012	10265EV	537
Ford 2005	10266EV	538

Ford 1999	10663ET	536
Ford 1999	12509ET	531
Ford 1999	12508ET	530
Chevrolet 2008	12790ET	528
Chevrolet 2008	12791ET	527
Chevrolet 2010	12517ET	261
Chevrolet 2010	12519ET	260
Chevrolet 2010	12518ET	259
Chevrolet 2007	10618ET	516
Chevrolet 2007	10649ET	515
Chevrolet 2007	10615ET	514
Chevrolet 2007	10617ET	512
Chevrolet 2008	12500ET	508
Chevrolet 2008	10619ET	507
Chevrolet 2008	106664ET	506
Ford 1997	10705ET	505
Ford 2005	59009JT	501
Ford 2006	10246EV	500
Ford 2003	10256EV	283
Ford 2005	10245EV	282
Ford 2005	10250EV	280
Chevrolet 2011	10254EV	279
Chevrolet 2011	10255EV	277
GMC 2011	10253EV	276
Ford 2010	10242EV	275
Ford 2010	10244EV	274
Ford 2010	10243EV	273
GMC 2011	10206EV	271
GMC 2011	10205EV	270
GMC 2011	10204EV	269
GMC 2011	10203EV	268
GMC 2011	10201EV	267
GMC 2011	10202EV	266
Chevrolet 2010	12775ET	265
Chevrolet 2010	12776ET	264
Chevrolet 2010	12777ET	263
Chevrolet 2010	12793ET	262
Chevrolet 2006	GDB7892	Medic 9
Chevrolet 2010	FAF1834	Medic 21
Chevrolet 2010	FAF1833	Medic 20
Chevrolet 2010	FAF1832	Medic 19
Chevrolet 2010	FAF1831	Medic 18
Chevrolet 2001	DRM8076	Medic 16
Chevrolet 2003	DNJ1293	Medic 15
Chevrolet 2005	DDG8521	Medic 14
Chevrolet 2005	DDG8518	Medic 13

RESULT: **ADOPTED [UNANIMOUS]**
MOVER: Angela M. Wozniak, Councilmember
SECONDER: Diane Benczkowski, Councilmember
AYES: Rogowski, Kaminski, Wozniak, Benczkowski, Meyers
ABSENT: Mary Holtz



16. RESOLUTION 2014-238

Authorize Supervisor to Execute Agreement with People, Inc. For Stay Fit Nutrition Site at 11 Haley Lane

Sponsored By: Councilmember Kaminski, Councilmember Benczkowski

WHEREAS, the Town of Cheektowaga Senior Services Department operates six (6) Stay Fit Dining programs in conjunction with the Erie County Department of Senior Services, and

WHEREAS, by resolution dated December 2, 2013 (Resolution 2013-608), the Town Board approved agreements with the six (6) nutrition sites for the Stay Fit Dining program, and

WHEREAS, one of the sites, Bell Tower Senior Apartments, has notified the Town that it can no longer accommodate our nutrition program at their location, effective April 30, 2014, and

WHEREAS, People, Inc., which owns the Violet Senior Apartments at 11 Haley Lane, has agreed to permit the Town of Cheektowaga to operate a nutrition program at this location, NOW, THEREFORE, BE IT

RESOLVED, that the Supervisor be and hereby is authorized and directed to execute an agreement with People, Inc. to utilize the Violet Senior Apartment complex at 11 Haley Lane in the Town of Cheektowaga for a site for the Stay Fit Dining Program for the remainder of 2014.

RESULT:	ADOPTED [UNANIMOUS]
MOVER:	Gerald Kaminski, Councilmember
SECONDER:	Diane Benczkowski, Councilmember
AYES:	Rogowski, Kaminski, Wozniak, Benczkowski, Meyers
ABSENT:	Mary Holtz



17. RESOLUTION 2014-239

Authorize Supervisor to Execute Contracts for the 2014 Crabapple Festival

Sponsored By: Councilmember Rogowski, Councilmember Meyers

BE IT RESOLVED, that the Supervisor is hereby authorized to execute contracts and agreements between the Town of Cheektowaga and performers and vendors for the 6th Annual Crabapple Festival, to be held on June 6th, 7th and 8th, 2014, subject to approval by the Town Attorney.

RESULT:	ADOPTED [UNANIMOUS]
MOVER:	James P. Rogowski, Councilmember
SECONDER:	Timothy J. Meyers, Councilmember
AYES:	Rogowski, Kaminski, Wozniak, Benczkowski, Meyers
ABSENT:	Mary Holtz



18. RESOLUTION 2014-240

Authorize Supervisor to Execute Contracts for the 2014 Polish American Arts Festival

Sponsored By: Councilmember Rogowski, Councilmember Wozniak

BE IT RESOLVED, that the Supervisor is hereby authorized to execute contracts and agreements between the Town of Cheektowaga and performers and vendors for the 36th Annual Polish American Arts Festival, to be held on July 17th, 18th, 19th, and 20th, 2014, subject to approval by the Town Attorney.

RESULT:	ADOPTED [UNANIMOUS]
MOVER:	James P. Rogowski, Councilmember
SECONDER:	Angela M. Wozniak, Councilmember
AYES:	Rogowski, Kaminski, Wozniak, Benczkowski, Meyers
ABSENT:	Mary Holtz



19. RESOLUTION 2014-241

Special Event - Crabapple Festival

Sponsored By: Councilmember Rogowski, Councilmember Wozniak

WHEREAS, by resolution dated May 1, 1995, this Town Board adopted a Special Events policy, which requires anyone wishing to hold a special event in the Town to file an application and supporting documentation, fees, etc. to the Town Clerk prior to the special event; and

WHEREAS, Supervisor Mary Holtz has made application to hold the 6th Annual Crabapple Festival - Celebration of the Town of Cheektowaga on June 6th, 7th, and 8th, 2014; and

WHEREAS, this Board has reviewed the aforementioned application, which application has been approved by the Facilities Department, Police Department and the Department of Recreation & Youth Services, and has no objection to same; and

WHEREAS, due to the nature of the event, this Town Board hereby waives the following requirements:

- Submittal of plan for sanitary facilities;
- Submittal of site plan;
- Submittal of Security Plan;
- Submittal of Fire Prevention/Emergency Services Plan;
- Certificate of Insurance from Cheektowaga Patriotic Commission;

NOW, THEREFORE, BE IT

RESOLVED, that this Town Board hereby approves the aforementioned application of Supervisor Mary Holtz for the aforementioned 6th Annual Crabapple Festival - Celebration of the Town of Cheektowaga to be held on June 6th, 7th and 8th, 2014.

RESULT:	ADOPTED [UNANIMOUS]
MOVER:	James P. Rogowski, Councilmember
SECONDER:	Angela M. Wozniak, Councilmember
AYES:	Rogowski, Kaminski, Wozniak, Benczkowski, Meyers
ABSENT:	Mary Holtz



20. RESOLUTION 2014-242

Special Event - Polish Festival

Sponsored By: Councilmember Rogowski, Councilmember Benczkowski

WHEREAS, by resolution dated May 1, 1995, this Town Board adopted a Special Events policy, which requires anyone wishing to hold a special event in the Town to file an application and supporting documentation, fees, etc. to the Town Clerk prior to the special event, and

WHEREAS, the Cheektowaga Polish-American Arts Festival Committee has made application to hold its annual Polish-American Cultural Festival in Cheektowaga Town Park from Friday, July 18th thru Sunday, July 20th, 2014; and

WHEREAS, this Board has reviewed the aforementioned application, which application has been approved by the Facilities Department, the Department of Recreation & Youth Services, Police Department, Highway Department and has no objection to same, and

WHEREAS, due to the nature of the event, this Town Board hereby waives the following requirements:

- . Submittal of plan for sanitary facilities;
- . Submittal of site plan;
- . Requirement that application be made at least 60 days prior to the date of the special event;
- . Submittal of Security Plan;
- . Submittal of Fire Prevention/Emergency Services Plan;

NOW, THEREFORE, BE IT

RESOLVED, that this Town Board hereby approves the aforementioned application of the Cheektowaga Polish-American Arts Festival Committee for the aforementioned Polish-American Cultural Festival to be held in Cheektowaga Town Park from July 18th thru July 20th, 2014.

RESULT:	ADOPTED [UNANIMOUS]
MOVER:	James P. Rogowski, Councilmember
SECONDER:	Diane Benczkowski, Councilmember
AYES:	Rogowski, Kaminski, Wozniak, Benczkowski, Meyers
ABSENT:	Mary Holtz



21. RESOLUTION 2014-243

Special Event - Cheektowaga Girls Fastpitch Softball Parade

Sponsored By: Councilmember Meyers, Councilmember Rogowski

WHEREAS, by resolution dated May 1, 1995, this Town Board adopted a Special Events policy, which requires anyone wishing to hold a special event in the Town to file an application and supporting documentation, fees, etc. to the Town Clerk prior to the special event; and

WHEREAS, Cheektowaga Girls Fastpitch Softball has made application to hold a parade on Saturday, June 7, 2014, from 10:30 a.m. to approximately 11:00 a.m., said parade to begin at ball diamonds (George Urban Blvd at McNaughton), west onto George Urban Boulevard, right on E. Grand, follow onto Grand, left on West Grand, left on George Urban back to softball diamonds; and

WHEREAS, this Board has reviewed the aforementioned application, which application has been approved by the Police Department, the Department of Youth and Recreation, Highway Department and the Facilities Department, and has no objection to same; and

WHEREAS, due to the nature of the event, this Town Board hereby waives the following requirements:

1. Submittal of plan for sanitary facilities;
2. Submittal of site plan;
3. Requirement that application be made at least 60 days prior to the date of the special event;
4. Submittal of Security Plan;
5. Submittal of Fire Prevention/Emergency Services Plan;

NOW, THEREFORE, BE IT

RESOLVED, that this Town Board hereby approves the application of the Cheektowaga Girls Fastpitch Softball for the aforementioned parade, to be held on Saturday, June 7, 2014 ; BE IT FURTHER

RESOLVED, that the Chief of Police be and hereby is directed to provide traffic safety and escort services for such parade and to ensure compliance with Section 1660(a)(6) of the Vehicle and Traffic Law.

RESULT:	ADOPTED [UNANIMOUS]
MOVER:	Timothy J. Meyers, Councilmember
SECONDER:	James P. Rogowski, Councilmember
AYES:	Rogowski, Kaminski, Wozniak, Benczkowski, Meyers
ABSENT:	Mary Holtz



22. RESOLUTION 2014-244

Unsafe-Unsecured/43 Cloverdale Road

Sponsored By: Councilmember Kaminski, Councilmember Rogowski

WHEREAS, Town of Cheektowaga Law for the Administration and Enforcement of the Codes of New York State; and the Property Maintenance Code of New York State require that all vacant structures and premises shall be maintained in clean, safe, secure and sanitary conditions so as not to cause a blighting problem or adversely affect the public health or safety and all nuisances abated, AND

WHEREAS, the Town of Cheektowaga has received notification of an unsafe structure and premises located at 43 Cloverdale Road, Cheektowaga, New York SBL# 91.06-11-12 That is a danger to the safety of others, and records kept by the Assessors Office identify State of New York Mortgage, 2929 Walden Avenue, Depew, New York 14043, as the owner AND

WHEREAS, an inspection of such premises was conducted at 43 Cloverdale Road, by the Housing and Neighborhood Preservation Office, AND

WHEREAS, such inspection found the premises to be deteriorated, vacant, a hazard, and a danger to the safety and well being of others, AND

WHEREAS, the Town of Cheektowaga Housing and Neighborhood Preservation Office properly notified the property owner in accordance with the Town of Cheektowaga Law for the Administration and Enforcement of the Codes of New York State, and the owner failed to take actions to safeguard the premises, AND

WHEREAS, these conditions require the Town of Cheektowaga Housing and Neighborhood Preservation Office to take immediate steps to safeguard the premises to protect the health and safety of others and abate all nuisances, NOW, THEREFORE BE IT

RESOLVED, that pursuant to Section 70-7A.(5) and Section 70-8 of the Town of Cheektowaga Law for the Administration and Enforcement of the Codes of New York State that the vacant structure premises be safeguarded and all nuisances abated; and all costs incurred be assessed against the property hereinbefore described.

RESULT:	ADOPTED [UNANIMOUS]
MOVER:	Gerald Kaminski, Councilmember
SECONDER:	James P. Rogowski, Councilmember
AYES:	Rogowski, Kaminski, Wozniak, Benczkowski, Meyers
ABSENT:	Mary Holtz



23. RESOLUTION 2014-245

Unsafe-Unsecured/31 East End Avenue

Sponsored By: Councilmember Kaminski, Councilmember Rogowski

WHEREAS, Town of Cheektowaga Law for the Administration and Enforcement of the Codes of New York State; and the Property Maintenance Code of New York State require that all vacant structures and premises shall be maintained in clean, safe, secure and sanitary conditions so as not to cause a blighting problem or adversely affect the public health or safety and all nuisances abated, AND

WHEREAS, the Town of Cheektowaga has received notification of an unsafe structure and premises located at 31 East End Avenue, Cheektowaga, New York SBL# 101.28-1-19 that is a danger to the safety of others, and records kept by the Assessors Office identify Norman and Marnie Snead, 31 East End Avenue, Cheektowaga, New York 14225, as the owner AND

WHEREAS, an inspection of such premises was conducted at 31 East End Avenue, by the Housing and Neighborhood Preservation Office, AND

WHEREAS, such inspection found the premises to be deteriorated, vacant, a hazard, and a danger to the safety and well being of others, AND

WHEREAS, the Town of Cheektowaga Housing and Neighborhood Preservation Office properly notified the property owner in accordance with the Town of Cheektowaga Law for the Administration and Enforcement of the Codes of New York State, and the owner failed to take actions to safeguard the premises, AND

WHEREAS, these conditions require the Town of Cheektowaga Housing and Neighborhood Preservation Office to take immediate steps to safeguard the premises to protect the health and safety of others and abate all nuisances, NOW, THEREFORE BE IT

RESOLVED, that pursuant to Section 70-7A.(5) and Section 70-8 of the Town of Cheektowaga Law for the Administration and Enforcement of the Codes of New York State that the vacant structure premises be safeguarded and all nuisances abated; and all costs incurred be assessed against the property hereinbefore described.

RESULT:	ADOPTED [UNANIMOUS]
MOVER:	Gerald Kaminski, Councilmember
SECONDER:	James P. Rogowski, Councilmember
AYES:	Rogowski, Kaminski, Wozniak, Benczkowski, Meyers
ABSENT:	Mary Holtz



24. RESOLUTION 2014-246

Unsafe Gutters-47 Loxley Road

Sponsored By: Councilmember Kaminski, Councilmember Rogowski

WHEREAS, Town of Cheektowaga Law for the Administration and Enforcement of the Codes of New York State; and the Property Maintenance Code of New York State require that all vacant structures and premises shall be maintained in clean, safe, secure and sanitary conditions so as not to cause a blighting problem or adversely affect the public health or safety and all nuisances abated, AND

WHEREAS, the Town of Cheektowaga has received notification of an unsafe structure and premises located at 47 Loxley Road, Cheektowaga, New York SBL# 91.77-2-17 that is a danger to the safety of others, and records kept by the Assessors Office identify Michele Isch, 47 Loxley Road, Cheektowaga, New York 14225, as the owner AND

WHEREAS, an inspection of such premises was conducted at 47 Loxley Road, by the Housing and Neighborhood Preservation Office, AND

WHEREAS, such inspection found the premises to be deteriorated, vacant, a hazard, and a danger to the safety and well being of others, AND

WHEREAS, the Town of Cheektowaga Housing and Neighborhood Preservation Office properly notified the property owner in accordance with the Town of Cheektowaga Law for the Administration and Enforcement of the Codes of New York State, and the owner failed to take actions to safeguard the premises, AND

WHEREAS, these conditions require the Town of Cheektowaga Housing and Neighborhood Preservation Office to take immediate steps to safeguard the premises to protect the health and safety of others and abate all nuisances, NOW, THEREFORE BE IT

RESOLVED, that pursuant to Section 70-7A.(5) and Section 70-8 of the Town of Cheektowaga Law for the Administration and Enforcement of the Codes of New York State that the vacant structure premises be safeguarded and all nuisances abated; and all costs incurred be assessed against the property hereinbefore described.

RESULT:	ADOPTED [UNANIMOUS]
MOVER:	Gerald Kaminski, Councilmember
SECONDER:	James P. Rogowski, Councilmember
AYES:	Rogowski, Kaminski, Wozniak, Benczkowski, Meyers
ABSENT:	Mary Holtz



25. RESOLUTION 2014-247

Youth & Recreation Terminations

Sponsored By: Councilmember Wozniak, Councilmember Rogowski

BE IT RESOLVED that the individuals listed below be and hereby are terminated in the Department of Youth & Recreational Services effective immediately:

Martin Acevedo	5/21/12	14206
Emalee Danner	5/20/13	14225
Scott Ferer	1/15/14	14215
Jacquelyn Reick	1/01/14	14225
Ashley Spencer	8/16/13	14211

Motion by Councilmember Rogowski; Seconded by Councilmember Meyers to waive the reading of names for the following three (3) resolutions: 2014-247, 2014-248 and 2014-249. Motion Carried.

RESULT: ADOPTED [UNANIMOUS]
MOVER: Angela M. Wozniak, Councilmember
SECONDER: James P. Rogowski, Councilmember
AYES: Rogowski, Kaminski, Wozniak, Benczkowski, Meyers
ABSENT: Mary Holtz



26. RESOLUTION 2014-248

Youth & Recreation Hiring/Transfers

Sponsored By: Councilmember Wozniak, Councilmember Rogowski

BE IT RESOLVED that the individuals listed below be and hereby are hired/transferred, as indicated, in the Department of Youth & Recreational Services, effective immediately:

Recreation Attendant - 7140.1633 - \$9.00 - Regular Part-time - Retro to 4/7/14
Slade Miller

Recreation Attendant - 7310.1814 - \$8.00 - Regular Part-time
Amanda Brodfuehrer 14227

Transfer from Adapted Recreation Program to Alexander Day Camp
Recreation Instructor to Recreation Specialist - 7310.1801 - \$11.25 - Regular Part-time
Deyonca Porter

Lifeguard - "Level II" - 7180.1903 - \$9.18 - Seasonal
Ross Bauman 14227
Ariana D'Agostino 14225
Katie Gramlich 14225
Amanda Kiripolsky 14215
Ryan Osswald 14225
Kyle Tobin 14215
Joseph Weber 14225
Alexandria Wnuk 14043

Lifeguard - "Level III" - 7180.1903 - \$9.36 - Seasonal
Samantha Burton 14225
William Dickinson 14225
Julianne Doetterl 14227
Zachary Hermanski 14225
Timothy Petranчук Jr. 14227
Stephanie Reesor 14211

Lifeguard - "Level IV" - 7180.1903 - \$9.55 - Seasonal
Brad Bauman 14227
Kayla Doetterl 14227
Margaret Drzewiecki 14225
Dakota Grantham 14225
Samantha Johnston 14227
Michael Keller 14225
Christopher Kiripolsky 14215
Allison Musial 14225
Katelin Petranчук 14227
Chelsea Waringer 14043
John Zastempowski IV 14227
Michael Zarbo 14227

RESULT: **ADOPTED [UNANIMOUS]**
MOVER: Angela M. Wozniak, Councilmember
SECONDER: James P. Rogowski, Councilmember
AYES: Rogowski, Kaminski, Wozniak, Benczkowski, Meyers
ABSENT: Mary Holtz



27. RESOLUTION 2014-249

Hiring/Termination of Part-Time/Seasonal Employees

Sponsored By: Councilmember Kaminski, Councilmember Benczkowski

BE IT RESOLVED, that the following individuals be and hereby are hired as **SEASONAL EMPLOYEES**, not to exceed five (5) months in a calendar year, in the various departments listed and in compliance with Civil Service Laws and Regulations as well as the provisions of the Town's collective bargaining agreement between the Town of Cheektowaga and the Town of Cheektowaga Employees Association:

MAIN PUMP STATION Laborer \$9.00/hour effective 5/26/14
Samuel W. Wodowski, Cheektowaga, New York

SANITATION DEPARTMENT Laborer \$9.25/hour effective 4/21/14
Derek R. Dalka, Cheektowaga, New York
Allen K. Steltermann, Cheektowaga, New York
William C. J. Merritt, Cheektowaga, New York
Walter W. Szafraniec, Cheektowaga, New York
Dominique Tramaine Pearsall, Cheektowaga, New York

SANITATION DEPARTMENT Laborer \$9.25/hour effective 4/14/14
Mark A. Carlucci, Depew, New York

OFFICE OF THE TOWN ASSESSOR Clerk \$9.00/hour effective 4/16/14
Michael G. Milks, Cheektowaga, New York

FACILITIES DEPARTMENT (Parks Division) Laborer \$8.25/hour
Mark R. Auguglia, Cheektowaga, New York effective 4/22/14
Matthew Rakowski, Cheektowaga, New York effective 6/3/14
Michael W. Kowal, Cheektowaga, New York effective 4/25/14
Michael D. Wawrzyniak, Cheektowaga, New York effective 4/22/14
Michael P. Wierzba, Cheektowaga, New York effective 5/19/14

FACILITIES DEPARTMENT (Parks Division) Laborer \$8.50/hour effective 5/10/14
Bryan C. Haxton, Cheektowaga, New York

FACILITIES DEPARTMENT (Parks Division) Laborer \$9.25/hour
Christian J. Suszek, Cheektowaga, New York effective 4/22/14

BE IT RESOLVED, that the following individual be and hereby is hired as a **PART-TIME EMPLOYEE** in the department listed, not to exceed nineteen (19) hours on a weekly basis, in compliance with Civil Service Laws and Regulations as well as the provisions of the Town's collective bargaining agreement between the Town of Cheektowaga and the Town of Cheektowaga Employees Association:

POLICE DEPARTMENT School Crossing Guard \$9.75/hour effective 4/7/14
Kenneth A. Carlucci, Jr., Cheektowaga, New York

BE IT RESOLVED, that the following seasonal and/or part-time employees be and hereby are terminated as listed:

POLICE DEPARTMENT

Matthew J. Speyer effective 4/12/14

FACILITIES DEPARTMENT

Richard E. Griffin effective 10/4/13

SANITATION DEPARTMENT

Mark A. Carlucci effective 4/15/14

BE IT RESOLVED, that the following employees' status be amended as follows:

SANITATION DEPARTMENT Laborer \$9.00/hour to \$9.25/hour effective 3/18/14

Michael J. Cristina, Cheektowaga, New York

Mark P. Mez, Cheektowaga, New York

JUSTICE COURT Clerk \$10.25/hour to \$15.00/hour effective 4/22/14

Mary Ann A. Szczepanowski, Cheektowaga, New York

FACILITIES DEPARTMENT (Parks Division) \$8.50/hour to \$9.25/hour effective 5/20/14

Ryan J. Kowal, Cheektowaga, New York

RESULT:	ADOPTED [UNANIMOUS]
MOVER:	Gerald Kaminski, Councilmember
SECONDER:	Diane Benczkowski, Councilmember
AYES:	Rogowski, Kaminski, Wozniak, Benczkowski, Meyers
ABSENT:	Mary Holtz



28. RESOLUTION 2014-250

Creation of Two (2) Assessment Clerks and One (1) Assistant Field Assessor Positions

Sponsored By: Councilmember Benczkowski, Councilmember Kaminski

BE IT RESOLVED, that this Town Board hereby create two (2) Assessment Clerks and one (1) Assistant Field Assessor position pursuant to Civil Service Laws and Rules effective April 22, 2014.

RESULT:	ADOPTED [UNANIMOUS]
MOVER:	Diane Benczkowski, Councilmember
SECONDER:	Gerald Kaminski, Councilmember
AYES:	Rogowski, Kaminski, Wozniak, Benczkowski, Meyers
ABSENT:	Mary Holtz



29. RESOLUTION 2014-251

Transfer of Clerk (Temporary) to Clerk (Part Time) Office of the Town Assessor/Amanda J. Murphy

Sponsored By: Councilmember Benczkowski, Councilmember Kaminski

WHEREAS, Amanda J. Murphy was appointed to the temporary position of Clerk in the Office of the Town Assessor; AND

WHEREAS, Ms. Murphy must revert to her former title of part-time Clerk as the temporary position is no longer available to her pursuant to Civil Service Law that limits temporary appointments to ninety (90) days; NOW, THEREFORE, BE IT

RESOLVED, that Amanda J. Murphy of Cheektowaga, New York, be and hereby is transferred from the position of temporary Clerk to her permanent title of part-time Clerk in the Office of the Town Assessor at the hourly rate of \$9.00 effective April 4, 2014.

RESULT:	ADOPTED [UNANIMOUS]
MOVER:	Diane Benczkowski, Councilmember
SECONDER:	Gerald Kaminski, Councilmember
AYES:	Rogowski, Kaminski, Wozniak, Benczkowski, Meyers
ABSENT:	Mary Holtz



30. RESOLUTION 2014-252

Appointment of Maintenance Worker (Temporary) Facilities Department (Buildings and Grounds Division)/Justin P. Borowski

Sponsored By: Councilmember Kaminski, Councilmember Meyers

WHEREAS, a temporary Maintenance Worker position exists in the Facilities Department (Buildings and Grounds Division); AND

WHEREAS, notice of such vacancy has been posted in accordance with the provisions of the Town's collective bargaining agreement with the Town of Cheektowaga Employees Association; AND

WHEREAS, no bargaining unit member bid on the vacancy; AND

WHEREAS, Justin P. Borowski applied for said vacancy and meets the qualifications for appointment; NOW, THEREFORE, BE IT

RESOLVED, that Justin P. Borowski of Cheektowaga, New York be and hereby is appointed to the temporary position of Maintenance Worker in the Facilities Department (Buildings and Grounds Division) in accordance with the terms and conditions of the Town's collective bargaining agreement with the Town of Cheektowaga Employees Association effective April 14, 2014.

RESULT:	ADOPTED [UNANIMOUS]
MOVER:	Gerald Kaminski, Councilmember
SECONDER:	Timothy J. Meyers, Councilmember
AYES:	Rogowski, Kaminski, Wozniak, Benczkowski, Meyers
ABSENT:	Mary Holtz



31. RESOLUTION 2014-253

Appointment of Senior Clerk Typist (Temporary) Justice Court/Andrea L. Spence

Sponsored By: Councilmember Benczkowski, Councilmember Kaminski

WHEREAS, a temporary vacancy exists in the position of Senior Clerk Typist in the Justice Court; AND

WHEREAS, the Town of Cheektowaga Employees Association has agreed to waive the posting of said vacancy; AND

WHEREAS, an intra-departmental poll was conducted and Andrea L. Spence, currently employed as a Court Clerk, has expressed interest in said vacancy and meets the qualifications for appointment; NOW, THEREFORE, BE IT

RESOLVED, that Andrea L. Spence of Cheektowaga, New York be and hereby is appointed to the temporary position of Senior Clerk Typist in the Justice Court in accordance with the terms and conditions of the Town's collective bargaining agreement with the Town of Cheektowaga Employees Association, effective April 21, 2014.

RESULT:	ADOPTED [UNANIMOUS]
MOVER:	Diane Benczkowski, Councilmember
SECONDER:	Gerald Kaminski, Councilmember
AYES:	Rogowski, Kaminski, Wozniak, Benczkowski, Meyers
ABSENT:	Mary Holtz



32. RESOLUTION 2014-254

Travel Authorization Police Department/Chief David Zack, Captains Michael Sliwinski and Michael Isbrandt

Sponsored By: Councilmember Benczkowski, Councilmember Kaminski

WHEREAS, the CALEO 21st Annual Training Symposium is being held May 21 through May 23, 2014 in Niagara Falls, Ontario; AND

WHEREAS, Police Chief David Zack, Captain Michael Sliwinski and Captain Michael Isbrandt have requested approval to attend said symposium; AND

WHEREAS, Police Chief David Zack has submitted a request for travel authorization along with the proper paperwork in a timely manner; AND

WHEREAS, the total cost to the Town shall not exceed \$1,764; AND

WHEREAS, these expenses have been budgeted by the Department; NOW,
THEREFORE, BE IT

RESOLVED, that Police Chief David Zack, Captain Michael Sliwinski and Captain Michael Isbrandt be and hereby are authorized to attend the CALEO 21st Annual Training Symposium being held May 21 through May 23, 2014 in Niagara Falls, Ontario.

RESULT:	ADOPTED [UNANIMOUS]
MOVER:	Diane Benczkowski, Councilmember
SECONDER:	Gerald Kaminski, Councilmember
AYES:	Rogowski, Kaminski, Wozniak, Benczkowski, Meyers
ABSENT:	Mary Holtz



33. RESOLUTION 2014-255

Travel Authorization Police Department/Detectives Michael Hockwater, Joseph Crean, Joseph Bauman and Joseph Stroud

Sponsored By: Councilmember Benczkowski, Councilmember Kaminski

WHEREAS, The Reid Technique of Investigative Interviewing for Child Abuse Investigations is being held June 17 through June 19, 2014 at the Town of Tonawanda Police Department ; AND

WHEREAS, Detectives Michael Hockwater, Joseph Crean, Joseph Bauman and Joseph Stroud have been recommended to attend said course; AND

WHEREAS, Police Chief David Zack has submitted a request for travel authorization along with the proper paperwork in a timely manner; AND

WHEREAS, the total cost to the Town shall not exceed \$1,796; AND

WHEREAS, these expenses have been budgeted by the Department; NOW, THEREFORE, BE IT

RESOLVED, that Detectives Michael Hockwater, Joseph Crean, Joseph Bauman and Joseph Stroud be and hereby are authorized to attend , The Reid Technique of Investigative Interviewing for Child Abuse Investigations Course being held June 17 through June 19, 2014 at the Town of Tonawanda Police Department.

RESULT:	ADOPTED [UNANIMOUS]
MOVER:	Diane Benczkowski, Councilmember
SECONDER:	Gerald Kaminski, Councilmember
AYES:	Rogowski, Kaminski, Wozniak, Benczkowski, Meyers
ABSENT:	Mary Holtz

V. Communications

A. Departmental Communications

1. Supervisor's Statement of Funds - February 2014
2. Building Permit List - March 2014

3. **Town of Cheektowaa Emergency Services - Quarterly Report from January to March 2014**
4. **Minutes: Cheektowaga Conservation Advisory Council - March 6, 2014**
5. **Minutes: Cheektowaga Conservation Advisory Council - April 3, 2014**
6. **Minutes: Cheektowaga Public Library - March 19, 2014**
7. **Minutes: Town Environmental Advisory Committee - April 2, 2014**

B. General Communications

1. **New York State Department of Transportation: Designation of Restricted Highway: NY Route 33 from Eggert Road to Holtz; Road including all ramps, a distance of approximately 4 miles**
2. **Summons & Complaint: Citimortgage Inc. vs. David Allen & Town of Cheektowaga Premises: 20 E Glenwood Ct.**
3. **Notice of Claim: GEICO for Deborah Davis vs. Town of Cheektowaga**
4. **Notice of Claim: Nicholas B. Horvath vs. Town of Cheektowaga**
5. **Notice of Claim: Stella Tukzynski vs. Town of Cheektowaga**

VI. Comments

A. Supervisor's Comments

B. Councilmember's Comments

C. Public Comments

VII. Adjournment

Motion by Councilmember Rogowski; Seconded by Councilmember Meyers to close the meeting at 8:22 PM

Alice Magierski, Town Clerk



Town of Cheektowaga

Regular Meeting

~ Minutes ~

3301 Broadway
Cheektowaga, NY 14227
<http://www.town.cheektowaga.ny.us>

Alice Magierski
716-686-3400

Monday, May 5, 2014

6:45 PM

Council Chambers

I. Call to Order

6:45 PM Meeting called to order on May 5, 2014 at Council Chambers, 3301 Broadway St, Cheektowaga, NY.

Attendee Name	Organization	Title	Status	Arrived
Mary Holtz	Town of Cheektowaga	Supervisor	Present	
James P. Rogowski	Town of Cheektowaga	Councilmember	Present	
Gerald Kaminski	Town of Cheektowaga	Councilmember	Present	
Angela M. Wozniak	Town of Cheektowaga	Councilmember	Present	
Diane Benczkowski	Town of Cheektowaga	Councilmember	Present	
Timothy J. Meyers	Town of Cheektowaga	Councilmember	Present	

2. Additional Attendees

Thomas Adamczak, Supervising Building and Plumbing Inspector
Brian Krause, Director of Finance and Administration
William Pugh, Town Engineer
Kevin Schenk, Town Attorney
Mark Wegner, Highway Superintendent
Jeffrey Whiting, Deputy Town Attorney

II. Public Comment Period

III. Public Hearing

1. Amend the Taxicabs Law

COMMENTS - Current Meeting:

This being the time and place advertised for a Public Hearing, the Supervisor directed the Town Clerk to present that such notice has been duly published and posted; upon the order of the Supervisor such proof was duly filed.

The Supervisor announced that the Town Board would hear all persons interested in the subject of the hearing. Comments were heard, after which the Supervisor declared the hearing closed, decision was reserved.

RESULT:	CLOSED [UNANIMOUS]
MOVER:	Timothy J. Meyers, Councilmember
SECONDER:	Mary Holtz, Supervisor
AYES:	Holtz, Rogowski, Kaminski, Wozniak, Benczkowski, Meyers

IV. From the Table



1. RESOLUTION 2014-228

Award of Bid - Sidewalk Replacement/ADA Ramp Installation (Bid #2014-19)

Sponsored By: Councilmember Kaminski, Councilmember Meyers

WHEREAS, as a result of advertisement, bids were received on April 16, 2014 for the replacement of sidewalks at various locations within the Town of Cheektowaga for the 2014 calendar year, AND

WHEREAS, said bids were referred to the Engineering Department for analysis and tabulation, NOW, THEREFORE, BE IT

RESOLVED, that the contract for the replacement of sidewalks be awarded to Yarussi Construction, Inc. For their submission of the lowest bid meeting the requirements of the specifications, AND, BE IT FURTHER

RESOLVED, that the bid for the replacement of sidewalks be and hereby is awarded to:

Yarussi Construction, Inc.
5650 Simmons Avenue
Niagara Falls, New York 14304

for the total bid price of \$575,200.00 for Bid Items 1 thru 3 for the year of 2014, AND, BE IT FURTHER

RESOLVED, that payment for said sidewalks shall be chargeable to the appropriate departmental budget line item.

RESULT:	ADOPTED [5 TO 1]
MOVER:	Gerald Kaminski, Councilmember
SECONDER:	Timothy J. Meyers, Councilmember
AYES:	Holtz, Rogowski, Kaminski, Benczkowski, Meyers
NAYS:	Angela M. Wozniak



2. RESOLUTION 2014-229

Award of Bid - Equipment & Operators for Public Works Projects (Bid #2014-20)

Sponsored By: Councilmember Kaminski, Councilmember Benczkowski

WHEREAS, as a result of advertisement, bids were received on April 16, 2014 for the furnishing of Equipment and Operators for Public Works Projects in the Town of Cheektowaga, AND

WHEREAS, said bids were referred to the Engineering Department for analysis and tabulation, NOW, THEREFORE, BE IT

RESOLVED, that the contract for the furnishing of Equipment and Operators for Public Works Projects in the Town of Cheektowaga for the period of May 5, 2014 to May 4, 2015 be awarded to Nichols, Long & Moore Construction Corporation, 149 Gunnville Road, Lancaster, New York 14086 for submission of the lowest bid meeting the specifications as per the unit prices of:

		May 5, 2014 - May 4, 2015 <u>Per Hour Rate</u>
Item 1	Tandem Dump Truck	\$80.00
Item 2	Hydraulic Rubber Tire Backhoe	\$76.00
Item 3	Pavement Saw Cutting Machine	\$100.00
Item 4	Hydraulic Crawler Backhoe (JD-160)	\$110.50
Item 5	Hydraulic Crawler Backhoe (JD-290)	\$95.00
Item 6	Bulldozer	\$90.00
Item 7	Front End Wheel Loader	\$108.00
Item 8	1.5 Ton Vibratory Blacktop Roller	\$75.00
Item 9	Hydraulic Crawler Backhoe W/Hammer	\$75.00
Item 10	Smooth Drum Dirt Roller	\$75.00
Item 11	Skilled Laborer	\$90.00
Item 12	Equipment Truck	\$ 6.00
Item 13	8' x 10' Trench Shield	\$ 1.00
Item 14	Air Compressor W/Hammers	\$ 7.50
Item 15	Sewer Line Repair Crew	\$342.00
Item 16	New Sewer Line Installation Crew	\$484.50

AND, BE IT FURTHER

RESOLVED, that payment for work performed under this contract shall be chargeable to the appropriate departmental budgeted line item.

RESULT:	ADOPTED [5 TO 1]
MOVER:	Gerald Kaminski, Councilmember
SECONDER:	Diane Benczkowski, Councilmember
AYES:	Holtz, Rogowski, Kaminski, Benczkowski, Meyers
NAYS:	Angela M. Wozniak

V. Resolutions



1. RESOLUTION 2014-256

Warrant

Sponsored By: Supervisor Holtz, Councilmember Kaminski

BE IT RESOLVED, that the following Vouchers & Warrants submitted to the Town of Cheektowaga prior to May 5, 2014 are hereby approved and made part hereof;

GENERAL FUND	\$5,783,145.55
RISK RETENTION FUND	933,924.88
NYS HOME PROGRAM	
DEBT	
HUD HOUSING REHABILITATION FUND	10,780.00
SPECIAL DISTRICTS FUND	1,028,859.83
HIGHWAY FUND	587,551.84
CAPITAL FUND	143,374.13
TRUST & AGENCY FUND	4,322.00
HUD CDBG FUND	14,944.36
PART TOWN FUND	8,561.41
NYS AFFORDABLE HOUSING	116,592.43
	<hr/>
	\$8,632,056.43

RESULT:	ADOPTED [UNANIMOUS]
MOVER:	Mary Holtz, Supervisor
SECONDER:	Gerald Kaminski, Councilmember
AYES:	Holtz, Rogowski, Kaminski, Wozniak, Benczkowski, Meyers



2. RESOLUTION 2014-257

Award of Bid for Disposal of Yard Waste (BID 2014-15 LAW)

Sponsored By: Councilmember Kaminski, Supervisor Holtz

WHEREAS, a Notice to Bidders was published for the Acceptance for Disposal of Yard Waste (Excepting Therefrom Highway Debris) Generated in and Collected by the Town of Cheektowaga for Calendar Years 2014-2018 (BID 2014-15 LAW); and

WHEREAS, one bid was received and opened by the Town Clerk at a public bid opening held on April 30, 2014, and same was reviewed by the Town Attorney; and

WHEREAS, the bid proposal price of \$17.20 per ton received from the sole bidder, Good Earth Organics Corp., for the 2014-2018 contract term, remains unchanged from the present per-ton price agreement with Good Earth; and

WHEREAS, the proposal submitted by Good Earth Organics Corp., meets all of the requirements of the bid specifications, and the Town Attorney recommends that the bid be awarded to Good Earth Organics Corp., NOW, THEREFORE, BE IT

RESOLVED, that the bid for the Acceptance for Disposal of Yard Waste (Excepting Therefrom Highway Debris) Generated in and Collected by the Town of Cheektowaga for Calendar Years 2014-2018 (BID 2014-15 LAW) be and hereby is awarded to Good Earth Organics Corp., 5960 Broadway, Lancaster, New York, 14086, being the sole bidder, at a per-ton price of \$17.20; and BE IT FURTHER

RESOLVED, that the Supervisor be and hereby is authorized to execute an agreement with Good Earth Organics Corp., subject to approval by the Town Attorney.

RESULT:	ADOPTED [UNANIMOUS]
MOVER:	Gerald Kaminski, Councilmember
SECONDER:	Mary Holtz, Supervisor
AYES:	Holtz, Rogowski, Kaminski, Wozniak, Benczkowski, Meyers



3. RESOLUTION 2014-258

Award of Bid - Pool Chemicals 2014 (Bid 2014-16)

Sponsored By: Councilmember Rogowski, Councilmember Wozniak

WHEREAS, sealed bids were received for Pool Maintenance Chemicals (Bid 2014-16) on April 16, 2014 at a meeting held for said purpose, AND

WHEREAS, said bids have been reviewed for in compliance under the terms of the specifications, NOW THEREFORE BE IT

RESOLVED, that the Cheektowaga Town Board hereby award said Bid for Pool Maintenance Chemicals to:

Alden Pools, Inc.
12890 Broadway
Alden, NY 14004

		FOR	
Category I	-	Bromine	- \$2.30 per lb.

Amrex Chemical Co., Inc.
391 Exchange Street
Buffalo, NY 14204

		FOR	
Category II	-	Diatomaceous Earth	- \$.34 per lb.
Category III	-	Sodium Bicarbonate	- \$.29 per lb.
Category IV	-	Soda Ash	- \$.285 per lb.

RESULT:	ADOPTED [UNANIMOUS]
MOVER:	James P. Rogowski, Councilmember
SECONDER:	Angela M. Wozniak, Councilmember
AYES:	Holtz, Rogowski, Kaminski, Wozniak, Benczkowski, Meyers



4. RESOLUTION 2014-259

Award of Bid - Athletic White Stripe 2014 (Bid 2014-17)

Sponsored By: Councilmember Rogowski, Councilmember Wozniak

WHEREAS, bids for Athletic White Stripe (Bid 2014-17) were received on April 16, 2014 at a meeting held for said purpose, AND

WHEREAS, said bids have been reviewed for in compliance under the terms of the specifications, NOW THEREFORE BE IT

RESOLVED, that the Cheektowaga Town Board hereby award said Bid for Athletic White Stripe to:

Allied Building Products
3401 Genesee Street
Cheektowaga, NY 14225

Athletic White Stripe at \$.084 per lb.

RESULT:	ADOPTED [UNANIMOUS]
MOVER:	James P. Rogowski, Councilmember
SECONDER:	Angela M. Wozniak, Councilmember
AYES:	Holtz, Rogowski, Kaminski, Wozniak, Benczkowski, Meyers



5. RESOLUTION 2014-260

Call for Public Hearing - Application for Transportation Alternatives Program Funding

Sponsored By: Supervisor Holtz, Councilmember Kaminski

WHEREAS, grant funding is available under the Federal Transportation Alternatives Program ("TAP"), which is administered by the NYS DOT, and

WHEREAS, TAP would reimburse the Town of Cheektowaga for the cost of construction of infrastructure-related projects and systems that will provide safe routes to schools and other pedestrian-related improvements, and

WHEREAS, the Town of Cheektowaga wishes to avail itself of said funding to provide safer intersection and sidewalk improvements to provide safer access to schools by our children, and

WHEREAS, in order to apply for said funding, this Town Board must hold a public hearing, NOW, THEREFORE, BE IT

RESOLVED, that a public hearing on the Town's proposed plan to apply for TAP funding shall be held on the 2nd day of June, 2014 at 6:45 P.M. at the Town Hall, 3301 Broadway, Cheektowaga, New York, at which time and place, interested members of the public shall be given an opportunity to comment on said plan, and BE IT FURTHER

RESOLVED, that the Town Clerk shall publish the attached Notice of Hearing in the Cheektowaga Bee.



**NOTICE OF HEARING
ON
TOWN OF CHEEKTOWAGA PLAN TO APPLY FOR
TRANSPORTATION ALTERNATIVES PROGRAM FUNDING**

NOTICE IS HEREBY GIVEN that a public hearing will be held by the Town Board of the Town of Cheektowaga, Erie County, New York at the Town Hall, 3301 Broadway, Cheektowaga, New York, on the 2nd day of June, 2014 at 6:45 P.M. on said day for the purpose of discussing and receiving public comment on the proposal of the Town of Cheektowaga to make application for Transportation Alternatives Program funding for the purpose of enhancing safe routes to schools by the construction of new sidewalks and intersection improvements near schools located in the Town of Cheektowaga:

BY ORDER OF THE TOWN BOARD OF THE TOWN OF CHEEKTOWAGA, ERIE COUNTY

May 5, 2014

ALICE MAGIERSKI, Town Clerk

RESULT:	ADOPTED [UNANIMOUS]
MOVER:	Mary Holtz, Supervisor
SECONDER:	Gerald Kaminski, Councilmember
AYES:	Holtz, Rogowski, Kaminski, Wozniak, Benczkowski, Meyers



6. RESOLUTION 2014-261

Call for Public Hearing - Amend Parks Ordinance

Sponsored By: Councilmember Rogowski, Councilmember Wozniak

WHEREAS, the Town of Cheektowaga previously adopted a Parks Ordinance (Chapter 174 of the Code of the Town of Cheektowaga) with amendments thereto, and Rules and Regulations governing Cheektowaga Town Parks which apply to Town parks and public park approaches owned by the Town of Cheektowaga, and

WHEREAS, the Cheektowaga Cultural Center in Cheektowaga Town Park is a venue for various concerts and events; oftentimes people sit and stand in close proximity to each other in the Cultural Center area (which includes the fenced in area around the Cultural Center and the Lion's Pavilion), and

WHEREAS, in the past, complaints have been registered by people utilizing the Cultural Center about smokers and smoking in the Cultural Center, and

WHEREAS, this Board feels that smoking should be prohibited in the Cultural Center area, NOW, THEREFORE, BE IT

RESOLVED, that, in accordance with the provisions of Section 130 of the Town Law of the State of New York, a public hearing will be held on the 19th day of May, 2014 at 6:45 P.M. at a meeting of the Town Board at the Cheektowaga Town Hall, 3301 Broadway, Cheektowaga, New York 14227, at which hearing all parties in interest and citizens shall have an opportunity to be heard and at which time and place it may be determined by the Town Board whether Chapter 174 of the Code of the Town of Cheektowaga ("Parks Ordinance") shall be amended as provided in the attached Notice of Hearing, and BE IT FURTHER

RESOLVED, that the Town Clerk shall publish the attached Notice of Hearing in the Cheektowaga Bee, the official Town newspaper, not less than ten (10) nor more than twenty (20) days prior to the public hearing



**NOTICE OF HEARING
ON PROPOSAL TO AMEND
CHAPTER 174 OF THE CODE OF THE TOWN OF CHEEKTOWAGA
("PARKS ORDINANCE")**

NOTICE IS HEREBY GIVEN THAT, in pursuance of a resolution of the Town Board of the Town of Cheektowaga, which was duly passed on the 5th day of May, 2014, and in accordance with the provisions of the Town Law of the State of New York, a Public Hearing will be held on the 19th day of May, 2014 at 6:45 P.M. at the Cheektowaga Town Hall, 3301 Broadway, Cheektowaga, New York; at such hearing, all parties in interest and citizens shall have an opportunity to be heard and, at which time and place, it may be determined by the

Town Board whether Chapter 174 of the Code of the Town of Cheektowaga ("Parks Ordinance") should be amended and changed as follows:

A new Section 174-7.1 of the Parks Ordinance shall be added to read as follows:

Section 174-7.1. Smoking within Cheektowaga Cultural Center prohibited.

Smoking shall be prohibited and no person shall smoke within the area (inside and outside any buildings) designated as the Cheektowaga Cultural Center. The Cheektowaga Cultural Center shall include the stage area, the bleachers, seating areas and the land within the fenced-in area around the Cultural Center. For purposes of this law, "smoking" means the burning of a lighted cigar, cigarette, pipe or other matter or substance which contains tobacco.

BY ORDER OF THE TOWN BOARD OF THE TOWN OF CHEEKTOWAGA, ERIE COUNTY, NEW YORK.

Dated: May 5, 2014

Alice Magierski, Town Clerk

RESULT:	ADOPTED [UNANIMOUS]
MOVER:	James P. Rogowski, Councilmember
SECONDER:	Angela M. Wozniak, Councilmember
AYES:	Holtz, Rogowski, Kaminski, Wozniak, Benczkowski, Meyers



7. RESOLUTION 2014-262

Notice of Public Hearing - Amend Prior Year Annual Plans

Sponsored By: Supervisor Holtz, Councilmember Kaminski

WHEREAS, the Town has received Community Development Block Grant funds and Home Investment Partnership program funds from the U.S. Department of HUD, and

WHEREAS, the Town wishes to change the uses initially proposed for those funds, and

WHEREAS, the Town is required to hold public hearings to obtain the views of Town residents, public agencies and other interested parties on proposed changes to the use of those funds, NOW, THEREFORE, BE IT

RESOLVED, that a public hearing be held on May 19, 2014 at 6:45 P.M. at Cheektowaga Town Hall, 3301 Broadway, Cheektowaga, New York 14227 for the above stated purpose, and BE IT

FURTHER RESOLVED, that the attached public notice of such public hearing be published in the Cheektowaga Bee on Thursday, May 7, 2014.

BY ORDER OF THE TOWN BOARD OF THE TOWN OF CHEEKTOWAGA, ERIE COUNTY, NEW YORK.

Dated: May 5, 2014

Alice Magierski, Town Clerk



Notice of Public Hearing to Amend Prior Year Annual Plans Community Development Block Grant and HOME Programs

A public hearing will be held on Monday, May 19, 2014 at 6:45 P.M. at Cheektowaga Town Hall, 3301 Broadway, Cheektowaga, NY 14227 on proposed changes to the Town's various prior Annual Plans for the use of Community Development Block Grant (CDBG) and HOME Investment Partnership Act (HOME) Programs, to obtain the views of citizens and interested parties on those proposed changes in housing and community development. The Annual Plan outlines housing and community development projects proposed to be funded with CDBG and HOME Program funds for a grant year. The proposed changes, outlined below, will be made available for public review in Town Hall, the Community Development Office, Cheektowaga Branch Libraries, and the Cheektowaga Bee. Those wishing to offer comments at the hearing are asked to also submit a written text, which may also be submitted to the Cheektowaga Community Development Office, 275 Alexander Avenue, Cheektowaga, New York, 14211. Interpreters will be made available at the meetings upon prior request to sign for the hearing impaired. If you need such special arrangements, contact the Cheektowaga Community Development Office at 897-7200, Ext. 7, at least seven (7) business days prior to the hearing.

The hearing location is accessible to the physically disabled.

Town of Cheektowaga
Community Development Block Grant Program
Annual Plan / Final Statement Amendment Report
2013-2014 - #1

The Town of Cheektowaga's Annual Plan / Final Statement on the Use of Community Development Block Grant and HOME Investment Partnership Funds is amended as follows:

Activities Added

(Activities added to include the demolition of one (1) residential structure on Randolph Street, relocation costs to move existing tenant to comparable existing housing, and construction of two (2) new homes for qualified low income households)

1. HOME Acquisition	2013	\$ 35,000.00
2. HOME Demolition	2013	20,000.00
3. HOME/CDBG Relocation Costs	2013	10,000.00
4. HOME New Construction (Including Soft Costs, hard costs, and CHDO Developer's Fee)	2013	420,000.00
(Activity added to include the construction of a multi-family residence on Union Road for the special needs disabled population – one (1) HOME unit funded)		
5. HOME Multi-Family New Construction	2013	75,000.00
Total		<u>\$ 560,000.00</u>

Activities Cancelled

(Activities no longer required)

1. HOME First-Time Homebuyers Program	2012	\$ (56,000.49)
2. HOME Housing Rehabilitation	2012	(238,210.49)
3. HOME First-Time Homebuyers Program	2013	(42,694.81)
4. Village of Sloan Smoke Detectors	2009	(1,000.00)
5. Village of Sloan Signage	2010	(3,500.00)
6. Village of Depew Home Safety Program	1999	(1,725.00)
7. Village of Depew Resident Security Improvements	2000	(8,000.00)
8. Village of Depew Resident Security Inspection Program	2000	(2,000.00)
9. Village of Depew Resident Security Improvements	2001	(10,000.00)
10. Village of Depew Resident Security Inspections	2001	(6,000.00)
11. Contingency/Unprogrammed Funds	2010	(1,072.76)
12. Contingency/Unprogrammed Funds	2011	(6,780.36)
13. Contingency/Unprogrammed Funds	2012	(4,001.00)
14. Rehabilitation Activity Delivery Costs – Staff & Expenses	2012	(10,000.00)
15. Fair Housing Study	2011	(3,300.00)
16. Fair Housing Study	2009	(8,500.00)
17. Village of Depew – Narcotics & Traffic Enforcement	2010	(6,746.15)
Total		<u>\$(409,531.16)</u>

Activities Modified

(Funding adjusted for actual need and actual expenditures)

1. HOME Housing Rehabilitation	2009	\$ (75.00)
2. HOME First-Time Homebuyers Program	2011	(21,084.46)
3. HOME Housing Rehabilitation	2011	(14,762.49)
4. HOME Housing Rehabilitation	2013	(187,172.16)
5. Village of Sloan Recreation Improvements & Facility/Park Equipment	2010	4,500.00
6. Village of Sloan Fire Department HVAC	2012	(170.00)
7. Village of Sloan Sidewalk Replacement	2011	(978.50)

8. Housing Rehabilitation – Single Family	2010	(13,989.25)
9. Housing Rehabilitation – Single Family	2012	98,838.87
10. Housing Rehabilitation – Single Family	2013	(78,965.96)
11. Domestic Violence Investigation Program	2012	(4,625.66)
12. Village of Depew Housing Rehabilitation – Single Family	2013	27,725.00
13. Rehab Activity Delivery Costs – Inspections	2012	33,549.18
14. Rehab Activity Delivery Costs	2013	83,331.48
15. Summer Day Camp	2013	(1,249.86)
16. Housing Counseling Services	2013	1,510.00
17. Clearance/Demolition	2008	(4,849.20)
18. Demolition	2010	(71,215.00)
19. Senior Services Outreach Assistant	2012	2,294.19
20. Fair Housing Study	2006	(4,322.07)
21. Accessibility – Bathroom Facilities at the Senior Center	2010	(2,504.10)
22. Village of Depew Police Foot Patrols	2012	(6,010.53)
23. Village of Depew Senior Citizen Center Staff	2012	(3,214.52)
24. Village of Depew Sidewalk Replacement	2013	15,971.20
Total		\$(150,468.84)

RESULT:	ADOPTED [UNANIMOUS]
MOVER:	Mary Holtz, Supervisor
SECONDER:	Gerald Kaminski, Councilmember
AYES:	Holtz, Rogowski, Kaminski, Wozniak, Benczkowski, Meyers



8. RESOLUTION 2014-263

Notice to Bidders - Reroofing the Senior Citizens Center (Bid #2014-23)

Sponsored By: Supervisor Holtz, Councilmember Kaminski

WHEREAS, it is in order that bids be advertised for Reroofing the Cheektowaga Senior Citizens Center (Bid 2014-23), 3349 Broadway, Cheektowaga, NY, AND

WHEREAS, the Cheektowaga Engineering Department has prepared specifications for the aforesaid project, NOW, THEREFORE, BE IT

RESOLVED, that the Town Clerk be directed to publish a Notice to Bidders for Reroofing the Cheektowaga Senior Citizens Center, said notice to be published in the CHEEKTOWAGA BEE, AND, BE IT FURTHER

RESOLVED, that sealed bids will be received on the 14th day of May, 2014 at 11:00 am at a public bid opening to be held in the Council Chambers in the Cheektowaga Town Hall.



NOTICE TO BIDDERS

NOTICE IS HEREBY GIVEN that sealed proposals will be received by the Town Board of the Town of Cheektowaga until 11:00 am, local time, on the 14th day of May, 2014. All bids will be publicly opened and read at 11:00 am at the Town Hall, 3301 Broadway, Cheektowaga, New York 14227 for furnishing all tools, equipment, materials, labor and incidentals required for the Reroofing of the Cheektowaga Senior Citizens Center (Bid 2014-23), 3349 Broadway, Cheektowaga, NY 14227, and all related work, complete in place, tested and ready for use in accordance with the Contract Documents, therefore, including Plans, Specifications, Instructions to Bidders, etc., prepared by the Town of Cheektowaga Engineering Department.

All proposals shall be submitted on the forms furnished herein and the entire volume, including any addenda, shall be submitted in a sealed envelope and addressed to the Town of Cheektowaga, 3301 Broadway, Cheektowaga, New York 14227, to the attention of Alice Magierski, Town Clerk, and marked as "Reroofing the Cheektowaga Senior Citizens Center".

Copies of the proposed Contract Documents, Plans, Specifications and Instructions to Bidders may be secured at the Town Clerk's Office, Town Hall, 3301 Broadway, Cheektowaga, New York 14227.

The work shall be completed within 30 consecutive calendar days, to begin five (5) days after the "Notice to Proceed" has been issued.

A pre-bid inspection will be held at the site (rear of facility) at 10:00 am on Monday, May 12th.

The right to reject any and all bids, to waive any informalities in, or to make an award to other than the low bidder, should it be deemed to be in the best interest of the Owner and in accordance with law, are herewith reserved.

Alice Magierski, Town Clerk

DATED: May 5, 2014

RESULT:	ADOPTED [UNANIMOUS]
MOVER:	Mary Holtz, Supervisor
SECONDER:	Gerald Kaminski, Councilmember
AYES:	Holtz, Rogowski, Kaminski, Wozniak, Benczkowski, Meyers



9. RESOLUTION 2014-264

Notice to Bidders - Roof Replacement on Town Hall Additions (Bid #2014-24)

Sponsored By: Supervisor Holtz, Councilmember Kaminski

WHEREAS, it is in order that bids be advertised for the Roof Replacement on four (4) Town Hall Additions at 3301 Broadway (Bid 2014-24), AND

WHEREAS, the Cheektowaga Engineering Department has prepared specifications for the aforesaid project, NOW, THEREFORE, BE IT

RESOLVED, that the Town Clerk be directed to publish a Notice to Bidders for Roof Replacement on the Town Hall Additions, said notice to be published in the CHEEKTOWAGA BEE, AND, BE IT FURTHER

RESOLVED, that sealed bids will be received on the 21st day of May, 2014 at 11:00 am at a public bid opening to be held in the Council Chambers in the Cheektowaga Town Hall.



NOTICE TO BIDDERS

NOTICE IS HEREBY GIVEN that sealed proposals will be received and considered by the Town Board of the Town of Cheektowaga, County of Erie, State of New York, on the 21st day of May, 2014 at 11:00 A.M., Local Time, in the Town Hall, Town of Cheektowaga, New York, for furnishing all labor, tools, equipment, materials and incidentals required for the Roof Replacement on four (4) Town Hall Additions at 3301 Broadway (Bid 2014-24), complete, in place, and ready for use in accordance with the Contract Documents, therefore, including Plans, Specifications, Instructions to Bidders, etc., prepared by the Town of Cheektowaga Engineering Department.

Copies of the proposed Contract Documents, Plans, Specifications and Instructions to Bidders may be secured at the Office of the Town Clerk in the Town Hall, Town of Cheektowaga, 3301 Broadway, Cheektowaga, New York.

All proposals shall be submitted on the forms furnished herein and the entire volume, including any addenda, shall be submitted in a sealed envelope and addressed to the Town of Cheektowaga, 3301 Broadway, Cheektowaga, New York 14227 to the attention of Alice Magierski, Town Clerk, and marked as "Roof Replacement on Town Hall Additions".

The right to reject any and all bids, to waive any informalities in, or to make an award to other than the low bidder, should it be deemed to be in the best interest of the Town of Cheektowaga and in accordance with law, are herewith reserved.

The work shall be completed within 60 consecutive calendar days, to begin five (5)

days after the "Order to Commence Work" has been issued.

Alice Magierski, Town Clerk

DATED: May 5, 2014

RESULT:	ADOPTED [UNANIMOUS]
MOVER:	Mary Holtz, Supervisor
SECONDER:	Gerald Kaminski, Councilmember
AYES:	Holtz, Rogowski, Kaminski, Wozniak, Benczkowski, Meyers



10. RESOLUTION 2014-265

Negative SEQR Declaration - 3035 Union Road Niagara Metals, LLC

Sponsored By: Councilmember Meyers, Supervisor Holtz

WHEREAS, pursuant to the Environmental Impact Review Ordinance of the Town of Cheektowaga, the Environmental Advisory Committee ("EAC") reviews various applications for site plans, rezonings, special permits, etc. and renders its recommendation concerning the environmental significance of such application, AND

WHEREAS, an application was submitted by Niagara Metals, LLC for the re-development of an existing lawful non conforming salvage facility at 3035 Union Road, AND

WHEREAS, the Town Board, pursuant to the Environmental Impact Review Ordinance of the Town of Cheektowaga, is designated the Lead Agency in most instances, AND

WHEREAS, the Town of Cheektowaga has identified the Town of Cheektowaga Zoning Board of Appeals as an "Involved Agency" and is coordinating its SEQRA review with the Zoning Board of Appeals, AND

WHEREAS, since the Town Board has designated itself as the Lead Agency, it must affirm, modify or reject any recommendations submitted to it by the Environmental Advisory Committee, AND

WHEREAS, Hazard Evaluations, Inc. Prepared a Phase One and Phase Two Environmental Site Assessment on behalf of the applicant which identified the need to perform mitigation of contaminated soils associated with the current salvage facility, AND

WHEREAS, the applicant will mitigate for such soil contamination during the re-development of the subject project site AND

WHEREAS, the applicant also prepared a Traffic Impact Study for the proposed re-development project, which, recommended the establishment of left hand turning lane along Union Road for southbound trucks entering the proposed Union Road driveway, AND

WHEREAS, the New York State Department of Transportation (NYSDOT) reviewed the subject project and the Traffic Impact Study, and concurs with the need for a left hand turning lane, AND

WHEREAS, NYSDOT has indicated that they will incorporate the pavement markings for such turning lane in its upcoming paving project for Union Road to occur this year, AND

WHEREAS, the New York State Department of Environmental Conservation (NYSDEC) has also reviewed the subject project and has indicated that they will be a permitting agency for the project, AND

WHEREAS, the applicant will be observing the regulatory requirements of NYSDEC for its proposed facility, AND

WHEREAS, the Town of Cheektowaga Planning Board recommended approval of the project site plan at their meeting of April 10, 2014, AND

WHEREAS, the Town of Cheektowaga Traffic Safety Commission has reviewed the subject project and is recommending its approval, AND

WHEREAS, the Environmental Advisory Committee at its meetings held on April 30, 2014 recommended a determination of non-significance as shown on the attached memorandum , AND

WHEREAS, this Town Board has reviewed the application submitted and the recommendations made by the Environmental Advisory Committee, the Planning Board and the Traffic Safety Commission NOW, THEREFORE, BE IT

RESOLVED, that this Town Board determines that the project will not have a significant effect on the environment and therefore issues a Negative Declaration for purposes of the State Environmental Quality Review Act (SEQRA).

RESULT:	ADOPTED [UNANIMOUS]
MOVER:	Timothy J. Meyers, Councilmember
SECONDER:	Mary Holtz, Supervisor
AYES:	Holtz, Rogowski, Kaminski, Wozniak, Benczkowski, Meyers



11. RESOLUTION 2014-266

Negative SEQR Declaration - 432 Dingens Street

Sponsored By: Councilmember Meyers, Supervisor Holtz

WHEREAS, pursuant to the Environmental Impact Review Ordinance of the Town of Cheektowaga, the Environmental Advisory Committee ("EAC") reviews various applications for site plans, rezonings, special permits, etc. and renders its recommendation concerning the environmental significance of such application, AND

WHEREAS, an application was submitted by Sunoco, Inc., (R&M) for the re-development of an existing lawful non conforming gas station /convenience store at 432 Dingens Street, AND

WHEREAS, the proposed redevelopment project will involve the demolition of the existing convenient store and gasoline canopy structures located within the Town of Cheektowaga, and the construction of a new canopy within the Town of Cheektowaga and a new 3,520 s.f. store building within the City of Buffalo, AND

WHEREAS, the re-development project also requires a rezoning from the current C-Retail Business District classification to MS- Motor Services, for that portion of the project within the Town of Cheektowaga, AND

WHEREAS, that portion of the development project within the City of Buffalo also required a zoning change, AND

WHEREAS, the City of Buffalo Approved such change in zoning for that portion of the project within their jurisdiction, AND

WHEREAS, the Town Board, pursuant to the Environmental Impact Review Ordinance of the Town of Cheektowaga, is designated the Lead Agency in most instances, AND

WHEREAS, the Town of Cheektowaga has identified the City of Buffalo as an "Involved Agency" and has coordinated its SEQRA review with the City of Buffalo, AND

WHEREAS, since the Town Board of the Town of Cheektowaga has designated itself as the Lead Agency, it must affirm, modify or reject any recommendations submitted to it by the Town of Cheektowaga Environmental Advisory Committee, AND

WHEREAS, that porton of the project within the Town of Cheektowaga requires area variances for the canopy and parking areas, AND

WHEREAS, the Cheektowaga Zoning Board of Appeals decision on the area variances will be pending following a hearing on May 21, 2014, AND

WHEREAS, the Town of Cheektowaga Planning Board recommended approval of the rezoning request and project site plan at their meetings of February 13, 2014, AND

WHEREAS, the Town of Cheektowaga Traffic Safety Commission has reviewed the subject project and is recommending its approval, AND

WHEREAS, the Environmental Advisory Committee at its meetings held on April 30, 2014 recommended a determination of non-significance as shown on the attached memorandum , AND

WHEREAS, this Town Board has reviewed the application submitted and the recommendations made by the Environmental Advisory Committee, the Planning Board and the Traffic Safety Commission NOW, THEREFORE, BE IT

RESOLVED, that this Town Board determines that the project will not have a significant effect on the environment and therefore issues a Negative Declaration for purposes of the State Environmental Quality Review Act (SEQRA) and directs the Town Clerk to provide a copy of this resolution to the City of Buffalo as an Involved Agency.

RESULT:	ADOPTED [UNANIMOUS]
MOVER:	Timothy J. Meyers, Councilmember
SECONDER:	Mary Holtz, Supervisor
AYES:	Holtz, Rogowski, Kaminski, Wozniak, Benczkowski, Meyers



12. RESOLUTION 2014-267

Establish Accounts for Consolidated Local Streets and Highway Improvement Program (CHIPS)

Sponsored By: Councilmember Kaminski, Supervisor Holtz

WHEREAS, in 1991, the State Legislature Restructured the Consolidated Local Street and Highway Improvement Program (CHIPS), creating a new payment mechanism for the capital project portions of the program, AND

WHEREAS, before the Town can avail itself of the CHIPS funding for capital project portion the Town must first spend the money and then seek reimbursement for CHIPS, AND

WHEREAS, a capital account must be established, moneys must be transferred into such account, and then money from such account will be spent, to be reimbursed later, NOW THEREFORE, BE IT

RESOLVED, and that the following accounts be and hereby are established:

CHIPS State Aid (Expense) #500-5132-0002-5714 - \$426,255.99
CHIPS State Aid (Revenue) #500-5132-0002-5714 - \$426,255.99

RESULT:	ADOPTED [UNANIMOUS]
MOVER:	Gerald Kaminski, Councilmember
SECONDER:	Mary Holtz, Supervisor
AYES:	Holtz, Rogowski, Kaminski, Wozniak, Benczkowski, Meyers



13. RESOLUTION 2014-268

Authorize Supervisor to Execute License Agreement with Leica, Inc. to Install Monitoring Wells on Rowan Road and Preston Road

Sponsored By: Councilmember Meyers, Supervisor Holtz

WHEREAS, by resolutions dated May 18, 2009 (Resolution 2009-282) and May 3, 2010 (Resolution 2010-254), the Town Board authorized Leica, Inc. to install nine (9) groundwater monitoring wells in the rights of way of Rowan Road and Preston Road south of the existing Leica, Inc. site located at 203 Eggert Road to monitor groundwater quality associated with the on-going site remedial activities being undertaken under a NYSDEC issued Consent Order, AND

WHEREAS, Leica Inc. has been directed by the New York State Department of Environmental Conservation (NYSDEC) to install an additional one (1) additional groundwater monitoring well on Preston Road, AND

WHEREAS, the Town Engineer and Superintendent of Highways have reviewed the proposed location of the one (1) well to be installed within the lawn area of Preston Road and find that said proposal will not interfere with the public use or maintenance of this Town highway right-of-way, AND

WHEREAS, this Town Board is supportive of NYSDEC efforts to conclude proper site remediation and monitoring activities at the former Leica site, NOW, THEREFORE, BE IT

RESOLVED, that this Town Board hereby approves of the aforementioned proposal to install One (1) additional monitoring well within the Preston Road highway right-of-way following the submission of proper insurance certifications acceptable to the Town Attorney from Leica Inc. and its project contractor, AND, BE IT FURTHER

RESOLVED, that the Supervisor be and hereby is authorized and directed to execute an addendum to the License Agreement with Leica, Inc. for this purpose, AND, BE IT FURTHER

RESOLVED, that the Town Engineer and Town Highway Superintendent be and hereby are directed to cooperate with the NYSDEC and environmental consultants engaged by Leica Inc. associated with remedial project monitoring.

RESULT:	ADOPTED [UNANIMOUS]
MOVER:	Timothy J. Meyers, Councilmember
SECONDER:	Mary Holtz, Supervisor
AYES:	Holtz, Rogowski, Kaminski, Wozniak, Benczkowski, Meyers



14. RESOLUTION 2014-269

Authorize Supervisor to Execute Agreement with NFTA

Sponsored By: Councilmember Benczkowski, Councilmember Kaminski

WHEREAS, the Niagara Frontier Transportation Authority Police Department (“NFTA PD”) is responsible for patrolling NFTA-owned properties and maintaining peace in and about the Buffalo Niagara International Airport located within the Town of Cheektowaga; and

WHEREAS, the NFTA PD provides aid and assistance to the Town’s Police Department when requested and/or when deemed necessary for the enforcement of law; and

WHEREAS, inasmuch as the NFTA does not maintain its own lock-up facilities, in 2007, it requested permission to transport individuals who are arrested on NFTA-owned properties within the Town’s boundaries to the Cheektowaga Police Department for detention pending initial court appearances as required, and the Town Board approved an agreement with the NFTA for this purpose; and

WHEREAS, the aforesaid agreement with the NFTA expired October 31, 2010, and the BNFTA has expressed interest in renewing said agreement for another three (3) years, and

WHEREAS, the Chief of Police has recommended that we continue this agreement, and

WHEREAS, in recognition of this mutual aid and cooperation, this Town Board is willing to enter into an Agreement with the NFTA governing the NFTA PD’s use of the Cheektowaga Police Department facilities; NOW THEREFORE, BE IT

RESOLVED, that the Agreement between the Town of Cheektowaga and the Niagara Frontier Transportation Authority, a copy of which is attached, is hereby approved, effective as of the 1st day of May, 2014 until April 30, 2017; and BE IT FURTHER

RESOLVED, that the Supervisor be and hereby is authorized and directed to execute said Agreement, subject to approval by the Town Attorney’s Office.

RESULT:	ADOPTED [UNANIMOUS]
MOVER:	Diane Benczkowski, Councilmember
SECONDER:	Gerald Kaminski, Councilmember
AYES:	Holtz, Rogowski, Kaminski, Wozniak, Benczkowski, Meyers



15. RESOLUTION 2014-270

Authorize Purchase of Long Gun Storage Units - Police Dept.

Sponsored By: Councilmember Benczkowski, Councilmember Kaminski

WHEREAS, due to the increased amount of weapons that is being seized and secured by the Cheektowaga Police Department each year, there is a need to maximize the property room space to its fullest potential; AND

WHEREAS, current storage of evidence and firearms in the Cheektowaga Police Department does not meet the suggested protocols and guidelines of the International Association for Property and Evidence Storage Association (IAPEA), AND

WHEREAS, SpaceSaver Storage Systems, Inc., c/o Henderson-Johnson Company, Inc., 918 Canal Street, Syracuse, New York 13210 offers a weapons/evidence storage system that would provide storage of 472 long guns and 416 handgun boxes and meet IAPEA guidelines; AND

WHEREAS, SpaceSaver Storage Systems offers New York State Contract Pricing under Contract #PC66520; AND

WHEREAS, the total cost for the Spacesaver 4-Post Shelving Unit for Long Gun and Hand Gun storage, including prevailing wage installation, is \$15,214.95; which will be paid for out of Police Asset Forfeiture Fund Account #600-0600-0881; NOW, THEREFORE, BE IT

RESOLVED, that the Cheektowaga Town Board hereby authorizes the purchase of the SpaceSaver 4-Post Shelving Unit for Long Gun and Hand Gun storage.

RESULT:	ADOPTED [UNANIMOUS]
MOVER:	Diane Benczkowski, Councilmember
SECONDER:	Gerald Kaminski, Councilmember
AYES:	Holtz, Rogowski, Kaminski, Wozniak, Benczkowski, Meyers



16. RESOLUTION 2014-271

Direct Grant Consultant to Submit Grant for TAP Funding

Sponsored By: Supervisor Holtz, Councilmember Kaminski

WHEREAS, grant funding is available under the Federal Transportation Alternatives Program ("TAP"), which is administered by the New York State Department of Transportation, and

WHEREAS, TAP would reimburse the Town of Cheektowaga for the cost of construction of infrastructure-related projects and systems that will provide safe routes to schools and other pedestrian-related improvements, and

WHEREAS, the Town of Cheektowaga wishes to avail itself of said funding to provide safer intersection and sidewalk improvements to provide safer access to schools by our children, NOW, THEREFORE, BE IT

RESOLVED, that the Town's grant consultant, KHEOPS Architecture, Engineering & Survey, D.P.C., be and hereby is authorized and directing to make application for TAP funding on behalf of the Town of Cheektowaga in an amount not to exceed \$2,500,000.00.

RESULT:	ADOPTED [UNANIMOUS]
MOVER:	Mary Holtz, Supervisor
SECONDER:	Gerald Kaminski, Councilmember
AYES:	Holtz, Rogowski, Kaminski, Wozniak, Benczkowski, Meyers



17. RESOLUTION 2014-272

Special Event - Southline Little League Baseball Parade

Sponsored By: Councilmember Meyers, Councilmember Rogowski

WHEREAS, by resolution dated May 1, 1995, this Town Board adopted a Special Events policy, which requires anyone wishing to hold a special event in the Town to file an application and supporting documentation, fees, etc. to the Town Clerk prior to the special event; and

WHEREAS, the Southline Little League Association has made application to hold its annual "Baseball Parade" on Monday, May 26, 2014, commencing at 9:30 A.M.; said parade route to start at the Garden Village Plaza, then down French Road to Towers Boulevard, then to North Seine Drive, and ending at the Southline Little League baseball diamonds; and

WHEREAS, this Board has reviewed the aforementioned application, which application has been approved by the Town Board on behalf of the Police Department, the Department of Youth and Recreation, Highway Department and the Facilities Department, and has no objection to same; and

WHEREAS, due to the nature of the event, this Town Board hereby waives the following requirements:

1. Submittal of plan for sanitary facilities;
2. Submittal of site plan;
3. Requirement that application be made at least 60 days prior to the date of the special event;
4. Submittal of Security Plan;
5. Submittal of Fire Prevention/Emergency Services Plan;

NOW, THEREFORE, BE IT

RESOLVED, that this Town Board hereby approves the application of Southline Little League Association for the aforementioned "Baseball Parade", to be held on Monday, May 26, 2014; and BE IT FURTHER

RESOLVED, that the Chief of Police be and hereby is directed to provide traffic safety and escort services for such parade and to ensure compliance with Section 1660(a)(6) of the Vehicle and Traffic Law.

RESULT:	ADOPTED [UNANIMOUS]
MOVER:	Timothy J. Meyers, Councilmember
SECONDER:	James P. Rogowski, Councilmember
AYES:	Holtz, Rogowski, Kaminski, Wozniak, Benczkowski, Meyers



18. RESOLUTION 2014-273

Special Event - Shooting Starz Charity Softball Tournament

Sponsored By: Councilmember Rogowski, Councilmember Meyers

WHEREAS, by resolution dated May 1, 1995, this Town Board adopted a Special Events policy, which requires anyone wishing to hold a special event in the Town to file an application and supporting documentation, fees, etc. to the Town Clerk prior to the special event, and

WHEREAS, the Shooting Starz Charity Softball Association has made application to hold its "Co-Ed Charity Softball Tournament" for Make-A-Wish Foundation in Stiglmeier Park on Saturday, July 26th, 2014 from 8:00 a.m. - 7:00 p.m. (Diamonds 1, 7, 8 & 9); and

WHEREAS, this Board has reviewed the aforementioned application, which application has been approved by the Police Department, Facilities Department and Youth & Recreational Services Department, and

WHEREAS, due to the nature of the event, this Town Board hereby waives the following requirements:

- . Submittal of plan for sanitary facilities;
- . Submittal of site plan;
- . Submittal of Security Plan;
- . Submittal of Fire Prevention/Emergency Services Plan;

NOW, THEREFORE, BE IT

RESOLVED, that this Town Board hereby approves the aforementioned application of the Shooting Starz Charity Softball Association for the aforementioned "Co-Ed Charity Softball Tournament" for Make-A-Wish Foundation in Stiglmeier Park on Saturday, July 26th, 2014.

RESULT:	ADOPTED [UNANIMOUS]
MOVER:	James P. Rogowski, Councilmember
SECONDER:	Timothy J. Meyers, Councilmember
AYES:	Holtz, Rogowski, Kaminski, Wozniak, Benczkowski, Meyers



19. RESOLUTION 2014-274

Special Event Cheektowaga Oldtimers Softball Playoffs

Sponsored By: Councilmember Rogowski, Councilmember Meyers

WHEREAS, by resolution dated May 1, 1995, this Town Board adopted a Special Events policy, which requires anyone wishing to hold a special event in the Town to file an application and supporting documentation, fees, etc. to the Town Clerk prior to the special event, and

WHEREAS, the Cheektowaga Oldtimers Softball League has made application to hold its annual "Super Sunday Softball Playoffs" at Stiglmeier Park (Diamond 1) on Sunday, August 17th, 2014 from 11:00 a.m. - 5:30 p.m.; AND

WHEREAS, this Board has reviewed the aforementioned application, which application has been approved by the Facilities Department and has no objection to same, and

WHEREAS, due to the nature of the event, this Town Board hereby waives the following requirements:

2. Submittal of plan for sanitary facilities;
3. Submittal of site plan;
4. Submittal of Security Plan;
5. Submittal of Fire Prevention/Emergency Services Plan.

NOW, THEREFORE, BE IT

RESOLVED, that this Town Board hereby approves the aforementioned application of the Cheektowaga Oldtimers Softball League for its annual "Super Sunday Softball Playoffs" at Stiglmeier Park (Diamond 1) on Sunday, August 17th, 2014.

RESULT:	ADOPTED [UNANIMOUS]
MOVER:	James P. Rogowski, Councilmember
SECONDER:	Timothy J. Meyers, Councilmember
AYES:	Holtz, Rogowski, Kaminski, Wozniak, Benczkowski, Meyers



20. RESOLUTION 2014-275

Unsafe Fence/25 John Brian Lane

Sponsored By: Supervisor Holtz, Councilmember Benczkowski

WHEREAS, Town of Cheektowaga Law for the Administration and Enforcement of the Codes of New York State; and the Property Maintenance Code of New York State require that all vacant structures and premises shall be maintained in clean, safe, secure and sanitary conditions so as not to cause a blighting problem or adversely affect the public health or safety and all nuisances abated, AND

WHEREAS, the Town of Cheektowaga has received notification of an unsafe structure and premises located at 25 John Brian Lane, Cheektowaga, New York SBL# 125.11-13-33 that is a danger to the safety of others, and records kept by the Assessors Office identify Steven & Collette Hatrick, 16 Lord Street, Buffalo, New York 14210, as the owner AND

WHEREAS, an inspection of such premises was conducted at 25 John Brian Lane, by the Housing and Neighborhood Preservation Office, AND

WHEREAS, such inspection found the premises to be deteriorated, vacant, a hazard, and a danger to the safety and well being of others, AND

WHEREAS, the Town of Cheektowaga Housing and Neighborhood Preservation Office properly notified the property owner in accordance with the Town of Cheektowaga Law for the Administration and Enforcement of the Codes of New York State, and the owner failed to take actions to safeguard the premises, AND

WHEREAS, these conditions require the Town of Cheektowaga Housing and Neighborhood Preservation Office to take immediate steps to safeguard the premises to protect the health and safety of others and abate all nuisances, NOW, THEREFORE BE IT

RESOLVED, that pursuant to Section 70-7A.(5) and Section 70-8 of the Town of Cheektowaga Law for the Administration and Enforcement of the Codes of New York State that the vacant structure premises be safeguarded and all nuisances abated; and all costs incurred be assessed against the property hereinbefore described.

RESULT:	ADOPTED [UNANIMOUS]
MOVER:	Mary Holtz, Supervisor
SECONDER:	Diane Benczkowski, Councilmember
AYES:	Holtz, Rogowski, Kaminski, Wozniak, Benczkowski, Meyers



21. RESOLUTION 2014-276

Unsafe-Gutters/17 Yvette Drive

Sponsored By: Supervisor Holtz, Councilmember Benczkowski

WHEREAS, Town of Cheektowaga Law for the Administration and Enforcement of the Codes of New York State; and the Property Maintenance Code of New York State require that all vacant structures and premises shall be maintained in clean, safe, secure and sanitary conditions so as not to cause a blighting problem or adversely affect the public health or safety and all nuisances abated, AND

WHEREAS, the Town of Cheektowaga has received notification of an unsafe structure and premises located at 17 Yvette Drive, Cheektowaga, New York SBL# 125.09-16-26 that is a danger to the safety of others, and records kept by the Assessors Office identify Russel Caci, 698 Borden Road, Cheektowaga, New York 14227, as the owner AND

WHEREAS, an inspection of such premises was conducted at 17 Yvette Drive, by the Housing and Neighborhood Preservation Office, AND

WHEREAS, such inspection found the premises to be deteriorated, vacant, a hazard, and a danger to the safety and well being of others, AND

WHEREAS, the Town of Cheektowaga Housing and Neighborhood Preservation Office properly notified the property owner in accordance with the Town of Cheektowaga Law for the Administration and Enforcement of the Codes of New York State, and the owner failed to take actions to safeguard the premises, AND

WHEREAS, these conditions require the Town of Cheektowaga Housing and Neighborhood Preservation Office to take immediate steps to safeguard the premises to protect the health and safety of others and abate all nuisances, NOW, THEREFORE BE IT

RESOLVED, that pursuant to Section 70-7A.(5) and Section 70-8 of the Town of Cheektowaga Law for the Administration and Enforcement of the Codes of New York State that the vacant structure premises be safeguarded and all nuisances abated; and all costs incurred be assessed against the property hereinbefore described.

RESULT:	ADOPTED [UNANIMOUS]
MOVER:	Mary Holtz, Supervisor
SECONDER:	Diane Benczkowski, Councilmember
AYES:	Holtz, Rogowski, Kaminski, Wozniak, Benczkowski, Meyers



22. RESOLUTION 2014-277

Over the Edge Program 2014

Sponsored By: Councilmember Wozniak, Councilmember Rogowski

WHEREAS, the Department of Youth and Recreational Services is desirous of holding its Summer Youth Theater Program June 30, 2014 thru July 10, 2014 at Villa Maria College, and

WHEREAS, the College has offered use of its recital hall and auditorium for the above mentioned program, NOW, THEREFORE BE IT

RESOLVED, that upon approval by the Town Attorney, the Supervisor be and hereby is authorized and directed to execute a no cost rental agreement with Villa Maria College for the Youth & Recreational Services Department "Over the Edge" Summer Theater Program.

RESULT:	ADOPTED [UNANIMOUS]
MOVER:	Angela M. Wozniak, Councilmember
SECONDER:	James P. Rogowski, Councilmember
AYES:	Holtz, Rogowski, Kaminski, Wozniak, Benczkowski, Meyers



23. RESOLUTION 2014-278

2014 Youth Development Award Contract

Sponsored By: Councilmember Wozniak, Councilmember Rogowski

BE IT RESOLVED that subject to the approval of the Town Attorney, the Supervisor of the Town of Cheektowaga be and hereby is authorized to execute the 2014 Youth Development Program Award Contract #LYB-825 in the amount of \$35,891.00 on behalf of the Department of Youth & Recreational Services and the Erie County Youth Bureau.

RESULT:	ADOPTED [UNANIMOUS]
MOVER:	Angela M. Wozniak, Councilmember
SECONDER:	James P. Rogowski, Councilmember
AYES:	Holtz, Rogowski, Kaminski, Wozniak, Benczkowski, Meyers



24. RESOLUTION 2014-279

Youth & Recreation Hiring

Sponsored By: Councilmember Wozniak, Councilmember Rogowski

BE IT RESOLVED that the individuals listed below be and hereby are hired/transferred, as indicated, in the Department of Youth & Recreational Services, effective immediately:

Recreation Attendant - 7140.1614 - \$8.75 - Seasonal

Harley Wiertel 14227

Recreation Attendant - 7140.1614 & 7140.1636 - \$8.00 - Regular Part-time

Cody Jeziorski 14227

Recreation Attendant - 7140.1646 - \$8.25 - Regular Part-time

Samantha Wayne 14227

Recreation Attendant - 7140.1646 - \$8.75 - Regular Part-time

Joshua Strzelec 14211

Alexis Wayne 14227

Lifeguard - "Level I" - 7180.1903 - \$9.00 - Seasonal

Connor Karek 14225

Brandon Seifert 14225

Colleen Wilkie 14043

Lifeguard - "Level II" - 7180.1903 - \$9.18 - Seasonal

Kelsey Wiegert 14211

Lifeguard - "Level III" - 7180.1903 - \$9.36 - Seasonal

Noah McGhee 14225

Recreation Aide - 7310.1801 - Alexander Day Camp - \$8.00 - Part-time

Grace Dalton 14227

Charles McGregor 14227

Brianna Poules 14227

David Taylor 14215

Mariah Wilson 14225

Recreation Attendant - 7310.1801 - Alexander Day Camp - \$8.00 - Seasonal

Chelsey Balistriero 14225

Kaitlyn Kraebel 14227

Michael McGregor 14227

Morgan Miecznikowski 14225

Cassidy Moore 14225

Robert Pulkownik 14227

Ashley Schrader 14225

Recreation Attendant - 7310.1801 - Alexander Day Camp - \$8.15 - Seasonal

Samantha Poules 14227

Ashley Sokol	14227
Cerene Usinski	14225

Recreation Attendant - 7310.1801 - Alexander Day Camp - \$8.25 - Seasonal

Joshua Fruchtel	14211
Stephen Kelly	14211
Robyn Stanley	14225

Recreation Attendant - 7310.1801 - Alexander Day Camp - \$8.30 - Seasonal

Meghan Eckle	14225
--------------	-------

Recreation Attendant - 7140.1632 - Dartwood Day Camp - \$8.15 - Seasonal

Rebecca Langa	14043
---------------	-------

Recreation Attendant - 7140.1632 - Dartwood Day Camp - \$8.25 - Seasonal

Lori Majewski	14227
Kristen Schugardt	14043

Recreation Attendant - 7140.1636 - \$8.25 - Regular Part-time

Alexa Scharf	14225
--------------	-------

Cheektowaga Conservation Corps (CCC)SeasonalLaborer - "Level I Participant" - 7310.1816 - \$8.00 - Seasonal

Tyler Diebold	14225
Gaetano Mancuso	14227
Trevor Wrona	14225
Steven Nichy	14043
Tyler Suchan	14227
Lukas Baumgart	14225
Ronald Jerozal	14227
James Urshel	14043
Logan Brunner	14043

Laborer - "Level II Participant" - 7310.1816 - \$8.15 - Seasonal

Daniel Wierzba	14212
Matthew Nichy	14043
Maryann Glab	14227
Leah Polvinale	14227
Kaylee Sandel	14227

Laborer - "Level III Participant" - 7310.1816 - \$8.25 - Seasonal

Brian Johnson	14227
Robert Rustowicz	14225

Laborer - "Level IV Participant" - 7310.1816 - \$8.30 - Seasonal

Christopher Kelley	14215
Christopher Suchan	14227
Zachary Uzar	14227

Laborer - "Level V Participant" - 7310.1816 - \$8.55 - Seasonal

Eric Nash	14206
-----------	-------

Laborer - "Level I Supervisor Trainee" - 7310.1816 - \$9.20 - Seasonal

James Hanners	14225
Alex Lenhard	14227

Laborer - "Level II Supervisor Trainee" - 7310.1816 - \$9.65 - Seasonal

Keith Kwiatkowski	14227
-------------------	-------

Laborer - "Level III Supervisor Trainee" - 7310.1816 - \$9.90 - Seasonal

Christopher Balash	14215
--------------------	-------

Laborer - "Level I Youth Leader" - 7310.1811 - \$9.65 - Seasonal

Matthew Lanning	14225
Daniel Eye	14225

Laborer - "Level II Youth Leader" - 7310.1811 - \$9.90 - Seasonal

Josh Galante	14206
Matthew Eckle	14225

Laborer - "Level I Crew Supervisor" - 7310.1811 - \$12.50 - Seasonal

Adam Skowron	14227
--------------	-------

Laborer - "Level II Crew Supervisor" - 7310.1811 - \$12.75 - Seasonal

Corey Smith	14043
-------------	-------

Laborer - "Level III Crew Supervisor" - 7310.1811 - \$13.00 - Seasonal

Andrew Samer	14227
Stephen Pfalzer	14043

Laborer - "Level I Participant" - 7310.1816 - \$8.00 - Seasonal - Alternate

Brandon Williams	14043
------------------	-------

Recreation Attendant - 7140.1636 - \$8.00 - Regular Part-time

Marshall Prestia	14211
------------------	-------

Recreation Attendant - 7140.1636 - \$8.35 - Regular Part-time

Andrew Deeds	14211
--------------	-------

Recreation Attendant - 7140.1636 - \$8.40 - Regular Part-time

Adam Barrett	14225
--------------	-------

BE IT FURTHER RESOLVED the following individuals be transferred as indicated:

Recreation Specialist - 7310.1811 - \$16.75 - Regular Part-time

Brad Agen

Recreation Specialist - 7310.1811 - \$14.50 - Regular Part-time

Jamie Nash

Motion by Councilmember Rogowski; Seconded by Councilmember Meyers to waive the reading of names for the following two (2) resolutions: 2014-279 and 2014-280. Motion carried.

RESULT:	ADOPTED [UNANIMOUS]
MOVER:	Angela M. Wozniak, Councilmember
SECONDER:	James P. Rogowski, Councilmember
AYES:	Holtz, Rogowski, Kaminski, Wozniak, Benczkowski, Meyers



25. RESOLUTION 2014-280

Hiring/Termination of Part-Time/Seasonal Employees

Sponsored By: Councilmember Kaminski, Supervisor Holtz

BE IT RESOLVED, that the following individuals be and hereby are hired as **SEASONAL EMPLOYEES**, not to exceed five (5) months in a calendar year, in the various departments listed and in compliance with Civil Service Laws and Regulations as well as the provisions of the Town's collective bargaining agreement between the Town of Cheektowaga and the Town of Cheektowaga Employees Association:

SANITATION DEPARTMENT Laborer \$9.25/hour effective 4/21/14

Marc P. Beang, Cheektowaga, New York

Keith M. Pignatora, Cheektowaga, New York

Nicholas M. Snyder, Cheektowaga, New York

SANITATION DEPARTMENT Laborer \$9.25/hour effective 4/14/14

Mark A. Carlucci, Depew, New York

SEWER MAINTENANCE Laborer

Sean F. Ross, Cheektowaga, New York \$9.25/hour effective 5/10/14

Christopher D. Gentile, Cheektowaga, New York \$9.00/hour effective 5/21/14

Adam J. Cartenuto, Cheektowaga, New York \$9.00/hour effective 5/21/14

Eric R. Cartenuto, Cheektowaga, New York \$9.00/hour effective 5/21/14

Nicholas B. Kotarski, Cheektowaga, New York \$8.75/hour effective 5/21/14

BE IT RESOLVED, that the following seasonal and/or part-time employees be and hereby are terminated as listed:

POLICE DEPARTMENT

Patricia H. Cwiklinski effective 3/28/14

RESULT:	ADOPTED [UNANIMOUS]
MOVER:	Gerald Kaminski, Councilmember
SECONDER:	Mary Holtz, Supervisor
AYES:	Holtz, Rogowski, Kaminski, Wozniak, Benczkowski, Meyers



26. RESOLUTION 2014-281

Retention of Coordinator of Employee Relations (Part-Time)

Sponsored By: Supervisor Holtz, Councilmember Kaminski

WHEREAS, Anthony M. Romano, Coordinator of Employee Relations, retired from said position, effective April 29, 2014, and

WHEREAS, the Town has received resúmes from various individuals for said position of Coordinator of Employee Relations, but has not completed the process for hiring a replacement for said position, and

WHEREAS, in the interim, this Town Board has requested Anthony M. Romano to work part-time for the Town to temporarily perform the duties of Coordinator of Employee Relations; and he has consented to same, NOW, THEREFIORE, BE IT

RESOLVED, that Anthony M. Romano be and hereby is hereby retained by the Town of Cheektowaga to serve as Coordinator of Employee Relation (part-time) at the rate of \$344.00 per day, effective as of May 1, 2014 and BE IT FURTHER

RESOLVED, that the Supervisor be and hereby is authorized and directed to execute any and all documents to retain Mr. Romano for these services.

RESULT:	ADOPTED [UNANIMOUS]
MOVER:	Mary Holtz, Supervisor
SECONDER:	Gerald Kaminski, Councilmember
AYES:	Holtz, Rogowski, Kaminski, Wozniak, Benczkowski, Meyers



27. RESOLUTION 2014-282

Appointments to the Plumbing Board (Kandefer, Blaser and Detzler)

Sponsored By: Supervisor Holtz, Councilmember Kaminski

WHEREAS, Chapter 70 of the Code of the Town of Cheektowaga ("Building Construction Codes Administration") was adopted by Local Law No. 5 of the Year 2004 for the purpose of administering the Building Codes of the State of New York; AND

WHEREAS, Section 70-17 of said Code establishes the Board of Plumbing and Drainage Examiners to oversee the licensing of plumbers in the Town of Cheektowaga; AND

WHEREAS, the Board of Plumbing and Drainage Examiners consists of the Town Engineer, the Town Supervising Code Enforcement Officer and three (3) persons who have engaged in the plumbing business for at least ten (10) years; AND

WHEREAS, there have been vacancies in the positions of three (3) plumbers on this Board since March 17, 2013; and inadvertently, reappointments were not timely made; AND

WHEREAS, the Supervising Code Enforcement Officer recommended the names of three plumbers to be appointed to the Town's Board of Plumbing and Drainage Examiners; NOW, THEREFORE, BE IT

RESOLVED, that the following plumbers be and hereby are appointed to the Board of Plumbing and Drainage Examiners, effective retroactively from March 17, 2013 to March 16, 2015:

Matthew Kandefer, Depew, New York
 Gary Blaser, Cheektowaga, New York
 John Detzler, Depew, New York.

RESULT:	ADOPTED [UNANIMOUS]
MOVER:	Mary Holtz, Supervisor
SECONDER:	Gerald Kaminski, Councilmember
AYES:	Holtz, Rogowski, Kaminski, Wozniak, Benczkowski, Meyers



28. RESOLUTION 2014-283

Appointments to the Plumbing Board (Kandefer, Blaser and Detzler)

Sponsored By: Supervisor Holtz, Councilmember Kaminski

WHEREAS, Chapter 70 of the Code of the Town of Cheektowaga ("Building Construction Codes Administration") was adopted by Local Law No. 5 of the Year 2004 for the purpose of administering the Building Codes of the State of New York; AND

WHEREAS, Section 70-17 of said Code establishes the Board of Plumbing and Drainage Examiners to oversee the licensing of plumbers in the Town of Cheektowaga; AND

WHEREAS, the Board of Plumbing and Drainage Examiners consists of the Town Engineer, the Town Supervising Code Enforcement Officer and three (3) persons who have engaged in the plumbing business for at least ten (10) years; AND

WHEREAS, there have been vacancies in the positions of three (3) plumbers on this Board since March 17, 2011; and inadvertently, re-appointments were not timely made; AND

WHEREAS, the Supervising Code Enforcement Officer recommended the names of three plumbers to be appointed to the Town's Board of Plumbing and Drainage Examiners; NOW, THEREFORE, BE IT

RESOLVED, that the following plumbers be and hereby are appointed to the Board of Plumbing and Drainage Examiners, effective retroactively from March 17, 2011 to March 16, 2013:

Matthew Kandefer, Depew, New York
 Gary Blaser, Cheektowaga, New York
 John Detzler, Depew, New York.

RESULT:	ADOPTED [UNANIMOUS]
MOVER:	Mary Holtz, Supervisor
SECONDER:	Gerald Kaminski, Councilmember
AYES:	Holtz, Rogowski, Kaminski, Wozniak, Benczkowski, Meyers



29. RESOLUTION 2014-284

Accept Resignation Letter

Sponsored By: Councilmember Kaminski, Supervisor Holtz

BE IT RESOLVED, that this Town Board hereby accepts the resignation letter from Kathleen M. McDonald from her position as Deputy Town Attorney (Prosecutor), effective May 2, 2014.

RESULT:	ADOPTED [UNANIMOUS]
MOVER:	Gerald Kaminski, Councilmember
SECONDER:	Mary Holtz, Supervisor
AYES:	Holtz, Rogowski, Kaminski, Wozniak, Benczkowski, Meyers



30. RESOLUTION 2014-285

Travel Authorization Police Department/Police Officer Paul Nazzarett

Sponsored By: Councilmember Benczkowski, Councilmember Kaminski

WHEREAS, the NYS Crime Prevention Coalition Basic Crime Prevention Course is being held June 9 through June 13, 2014 in Saratoga Springs, New York; AND

WHEREAS, Police Officer Paul Nazzarett has requested approval to attend said course; AND

WHEREAS, Police Chief David Zack has submitted a request for travel authorization along with the proper paperwork in a timely manner; AND

WHEREAS, the total cost to the Town shall not exceed \$1,162; AND

WHEREAS, these expenses have been budgeted by the Department; NOW, THEREFORE, BE IT

RESOLVED, that Police Officer Paul Nazzarett be and hereby is authorized to attend the NYS Crime Prevention Coalition Basic Crime Prevention Course being held June 9 through June 13, 2014 in Saratoga Springs, New York.

RESULT:	ADOPTED [UNANIMOUS]
MOVER:	Diane Benczkowski, Councilmember
SECONDER:	Gerald Kaminski, Councilmember
AYES:	Holtz, Rogowski, Kaminski, Wozniak, Benczkowski, Meyers



31. RESOLUTION 2014-286

Travel Authorization Police Department/Lieutenants Thomas Gerace and Brian Gould

Sponsored By: Councilmember Benczkowski, Councilmember Kaminski

WHEREAS, the FBINAA Conference 2014 is being held July 26 through July 29, 2014 in Philadelphia, Pennsylvania; AND

WHEREAS, Lieutenants Thomas Gerace and Brian Gould have requested approval to attend said conference; AND

WHEREAS, Police Chief David Zack has submitted a request for travel authorization along with the proper paperwork in a timely manner; AND

WHEREAS, the total cost to the Town shall not exceed \$2,324; AND

WHEREAS, these expenses have been budgeted by the Department; NOW,
THEREFORE, BE IT

RESOLVED, that Lieutenants Thomas Gerace and Brian Gould be and hereby are authorized to attend the FBINAA Conference 2014 being held July 26 through July 29, 2014 in Philadelphia, Pennsylvania.

RESULT:	ADOPTED [UNANIMOUS]
MOVER:	Diane Benczkowski, Councilmember
SECONDER:	Gerald Kaminski, Councilmember
AYES:	Holtz, Rogowski, Kaminski, Wozniak, Benczkowski, Meyers



32. RESOLUTION 2014-287

Travel Authorization Police Department/Police Officers Kurt Spieler, Michelle Wojtkowiak, Jacob Gawronski and Kevin Matusiak

Sponsored By: Councilmember Benczkowski, Councilmember Kaminski

WHEREAS, the 2014 National Law Enforcement Exploring Conference is being held July 13 through July 19, 2014 in Bloomington, Indiana; AND

WHEREAS, Police Officers Kurt Spieler, Michelle Wojtkowiak, Jacob Gawronski and Kevin Matusiak have been recommended to attend said conference; AND

WHEREAS, Police Chief David Zack has submitted a request for travel authorization along with the proper paperwork in a timely manner; AND

WHEREAS, the total cost to the Town shall not exceed \$3,759; AND

WHEREAS, these expenses have been budgeted by the Department; NOW, THEREFORE, BE IT

RESOLVED, that Police Officers Kurt Spieler, Michelle Wojtkowiak, Jacob Gawronski and Kevin Matusiak be and hereby are authorized to attend the 2014 National Law Enforcement Exploring Conference being held July 13 through July 19, 2014 in Bloomington, Indiana.

RESULT:	ADOPTED [UNANIMOUS]
MOVER:	Diane Benczkowski, Councilmember
SECONDER:	Gerald Kaminski, Councilmember
AYES:	Holtz, Rogowski, Kaminski, Wozniak, Benczkowski, Meyers

33. Suspension of Rules

Motion by Councilmember Rogowski; Seconded by Councilmember Kaminski to waive the Rules to Include the following two (2) resolutions: 2014-288 and 2014-289. Motion Carried.
--



1. RESOLUTION 2014-288

Notice to Bidders - Grass Cutting & Landscape Work for 2014 (BID 2014-22 CD)

Sponsored By: Supervisor Holtz, Councilmember Kaminski

WHEREAS, the Neighborhood Preservation Office, a Division of Community Development, is responsible for inspecting various properties within the Town of Cheektowaga to ensure compliance with Chapter 66 of Town Law, and

WHEREAS, the cleaning up of these properties includes grass cutting and other landscape-related work, and

WHEREAS, when violations are noted, property owners are notified to clean up their properties by cutting their grass, etc., and

WHEREAS, in the event property owners do not comply with clean up orders from the Housing & Neighborhood Preservation Office, and public health and safety require that action be taken immediately, it is necessary that the Housing & Neighborhood Preservation Office retain a private contractor to perform the necessary clean-up work on the property, and

WHEREAS, due to the projected annual cost for performing this work, it is in order that this Board advertise for bids for these services, and

WHEREAS, the Community Development Office, Neighborhood Preservation Office, and the Town Attorney's Office have drafted bid specifications for this purpose for calendar year 2014, NOW, THEREFORE, BE IT

RESOLVED, that the Town Clerk be and hereby is directed to publish a Notice to Bidders for Furnishing Equipment and Operators for Grass Cutting and Landscape Work on Vacant and Unmaintained Properties in the Town of Cheektowaga (BID 2014-22 CD) in the Cheektowaga Bee, and BE IT FURTHER

RESOLVED, that bids will be received until May 14, 2014 at 11:00 a.m. by the Town Clerk, who is hereby authorized and directed to publicly open all bids received at such time in the Council Chambers in the Cheektowaga Town Hall.



NOTICE TO BIDDERS

Sealed proposals will be received and considered by the Town Board of the Town of Cheektowaga on May 14, 2014 at 11:00 A.M., at the Town Hall, corner of Broadway and Union Roads, for Grass Cutting and Landscape Work on Vacant Land and Unmaintained Properties in the Town of Cheektowaga for 2014, said services to include mowing of grass, removal of brush, tree/bush/shrub trimming, cleaning flower beds and removal of garbage/debris.

Information for bidders and specifications may be obtained from the Town Clerk at her

office in said Town Hall.

Proposals shall be submitted in a sealed envelope plainly marked on the outside "Bid for Grass Cutting and Landscape Work for 2014 (BID 2014-22 CD)" and submitted to the Town Clerk prior to bid opening.

No bidder may withdraw his bid within forty-five (45) days after the actual date of the opening thereof.

The Town Board reserves the right to consider informal any bid not prepared and submitted in accordance with the provisions of the specifications and contract documents, and may waive any informalities, make an award to other than the low bidder, should it be in the best interest of the Town, or reject any or all bids.

Each proposal must be accompanied by a certified check for a sum equal to five percent (5%) of the amount of the bid, payable to the Town of Cheektowaga, New York, or bond with sufficient sureties to be approved by the attorney for the Town of Cheektowaga, New York.

BY ORDER OF THE TOWN BOARD OF THE TOWN OF CHEEKTOWAGA, ERIE COUNTY, NEW YORK.

Alice Magierski, Town Clerk

DATED: May 5, 2014

RESULT:	ADOPTED [UNANIMOUS]
MOVER:	Mary Holtz, Supervisor
SECONDER:	Gerald Kaminski, Councilmember
AYES:	Holtz, Rogowski, Kaminski, Wozniak, Benczkowski, Meyers



2. RESOLUTION 2014-289

Establish Accounts for Winter Recovery Program

Sponsored By: Councilmember Kaminski, Supervisor Holtz

WHEREAS, due to the extreme weather conditions of this past winter season, New York State has approved a one time \$40 million extreme winter recovery fund for the repair of roadways, AND

WHEREAS, the Town has received notification that New York State has appropriated \$50,207.96 of said fund to the Town, AND

WHEREAS, New York State Department of Transportation (NYSDOT) has been deemed the administering office for New York State, AND

WHEREAS, before the Town can avail itself to said funding for the repair of roadways the Town must first spend the money and seek reimbursement from (NYSDOT), AND

WHEREAS, a capital account must be established, moneys must be transferred into such account, and then money from such account will be spent, to be reimbursed later, NOW THEREFORE, BE IT

RESOLVED that the following accounts be and hereby are established:

500.5132.4650.5714 - \$50,207.96

RESULT:	ADOPTED [UNANIMOUS]
MOVER:	Gerald Kaminski, Councilmember
SECONDER:	Mary Holtz, Supervisor
AYES:	Holtz, Rogowski, Kaminski, Wozniak, Benczkowski, Meyers

VI. Communications

A. Departmental Communications

1. Supervisor's Statement of Funds - March 2014
2. Building Permit List - April 2014
3. Minutes: Cheektowaga Planning Board - April 10, 2014

4. Town of Cheektowaga 2014 Comprehensive Emergency Plan

B. General Communications

1. Drescher & Malecki: Annual Financial Report - Update Document for the Town of Cheekowaga for the Fiscal Year Ended December 31, 2013
2. Notice of Claim: Carolyn Arthur vs. Town of Cheektowaga
3. Notice of Claim: Alan J. Capozzi vs. Town of Cheektowaga
4. Notice of Claim: Nicholas Horvath vs. Town of Cheektowaga

VII. Comments

A. Supervisor's Comments

B. Councilmember's Comments

C. Public Comments

VIII. Adjournment

A moment of Silence for Matthew Kantor, Father in Law of Councilmember Timothy Meyers; Jean Rogowski, wife of the late Honorable John V. Rogowski and Lloyd Whiting, Father of Deputy Town Attorney, Jeffrey Whiting.

Motion by Supervisor Holtz; Seconded by Councilmember Kaminski to

Adjourn the meeting at 8:28 PM

Alice Magierski, Town Clerk



Town of Cheektowaga

Work Session

~ Minutes ~

3301 Broadway
Cheektowaga, NY 14227
<http://www.town.cheektowaga.ny.us>

Alice Magierski
716-686-3400

Tuesday, May 13, 2014

6:00 PM

Council Office

I. Call to Order

6:00 PM Meeting called to order on May 13, 2014 at Council Office, Conference Room, Cheektowaga, NY.

Attendee Name	Organization	Title	Status	Arrived
Mary Holtz	Town of Cheektowaga	Supervisor	Present	
James P. Rogowski	Town of Cheektowaga	Councilmember	Present	
Gerald Kaminski	Town of Cheektowaga	Councilmember	Present	
Angela M. Wozniak	Town of Cheektowaga	Councilmember	Present	
Diane Benczkowski	Town of Cheektowaga	Councilmember	Present	
Timothy J. Meyers	Town of Cheektowaga	Councilmember	Present	

2. Additional Attendees

Brian Krause, Director of Finance and Administration

Kevin Schenk, Town Attorney

II. Resolutions



1. RESOLUTION 2014-290

Authorize Supervisor to Execute Municipal Agreement with Village of Depew

Sponsored By: Councilmember Kaminski, Supervisor Holtz

WHEREAS, Zurbrick Road is a public highway, the northern one-half of which is owned and maintained by the Village of Depew, and the southern one-half of which is owned and maintained by the Town of Cheektowaga, and

WHEREAS, representatives of the Village of Depew and Town of Cheektowaga met to discuss the need to reconstruct and rehabilitate the Zurbrick Road pavement, said work to begin in 2014 and to be completed in subsequent years, and

WHEREAS, the Village of Depew and Town of Cheektowaga will each share in the cost of the Zurbrick Road improvements, and

WHEREAS, a municipal cooperation agreement is authorized under Article 5-G of the General Municipal Law, NOW, THEREFORE, BE IT

RESOLVED, that the Supervisor be and hereby is authorized and directed to execute the aforementioned municipal cooperation with the Village of Depew

RESULT:	ADOPTED [UNANIMOUS]
MOVER:	Gerald Kaminski, Councilmember
SECONDER:	Mary Holtz, Supervisor
AYES:	Holtz, Rogowski, Kaminski, Wozniak, Benczkowski, Meyers



2. RESOLUTION 2014-291

Appoint Deputy Town Attorney (with Prosecuting Duties)

Sponsored By: Councilmember Kaminski, Supervisor Holtz

WHEREAS, there is a vacancy in one of the positions of Deputy Town Attorney (with prosecutorial duties) as of May 2, 2014, and

WHEREAS, Anthony S. Pecoraro, Esq. has applied for said position and meets all necessary qualifications for same, NOW, THEREFORE, BE IT

RESOLVED, that, effective May 13, 2014, Anthony S. Pecoraro, Esq. be and hereby is appointed Deputy Town Attorney (with prosecutorial duties) at the salary established for said position, and BE IT FUTHER

RESOLVED, that in compliance with the Local Law known as the Residency Law of the Town of Cheektowaga, Anthony S. Pecoraro be and hereby is ordered to obtain residency within the Town of Cheektowaga on or before July 1, 2014.

RESULT:	ADOPTED [UNANIMOUS]
MOVER:	Gerald Kaminski, Councilmember
SECONDER:	Mary Holtz, Supervisor
AYES:	Holtz, Rogowski, Kaminski, Wozniak, Benczkowski, Meyers



Town of Cheektowaga

Regular Meeting

~ Minutes ~

3301 Broadway
Cheektowaga, NY 14227
<http://www.town.cheektowaga.ny.us>

Alice Magierski
716-686-3400

Monday, May 19, 2014

6:45 PM

Council Chambers

I. Call to Order

6:45 PM Meeting called to order on May 19, 2014 at Council Chambers, 3301 Broadway St, Cheektowaga, NY.

Attendee Name	Organization	Title	Status	Arrived
Mary Holtz	Town of Cheektowaga	Supervisor	Present	
James P. Rogowski	Town of Cheektowaga	Councilmember	Present	
Gerald Kaminski	Town of Cheektowaga	Councilmember	Present	
Angela M. Wozniak	Town of Cheektowaga	Councilmember	Present	
Diane Benczkowski	Town of Cheektowaga	Councilmember	Present	
Timothy J. Meyers	Town of Cheektowaga	Councilmember	Present	

2. Additional Attendees

Ellen Fischer, Executive Director - Youth Board
Brian Gould, Lieutenant, Police Department
Carla A. Kosmerl, Director of Community Development
Brian Krause, Director of Finance and Administration
William Pugh, Town Engineer
Kevin Schenk, Town Attorney
Mark Wegner, Highway Superintendent

II. Public Comment Period

III. Public Hearings

1. Amend Parks Ordinance

COMMENTS - Current Meeting:

This being the time and place advertised for a Public Hearing, the Supervisor directed the Town Clerk to present that such notice has been duly published and posted; upon the order of the Supervisor such proof was duly filed.

The Supervisor announced that the Town Board would hear all persons interested in the subject of the hearing. Comments were heard, after which the Supervisor declared the hearing closed, decision was reserved.

RESULT: CLOSED [UNANIMOUS]
MOVER: James P. Rogowski, Councilmember
SECONDER: Angela M. Wozniak, Councilmember
AYES: Holtz, Rogowski, Kaminski, Wozniak, Benczkowski, Meyers

2. Amend Prior Year Annual Plans - CDBG

COMMENTS - Current Meeting:

This being the time and place advertised for a Public Hearing, the Supervisor directed the Town Clerk to present that such notice has been duly published and posted; upon the order of the Supervisor such proof was duly filed.

The Supervisor announced that the Town Board would hear all persons interested in the subject of the hearing. Comments were heard, after which the Supervisor declared the hearing closed, decision was reserved.

RESULT: CLOSED [UNANIMOUS]
MOVER: Diane Benczkowski, Councilmember
SECONDER: Mary Holtz, Supervisor
AYES: Holtz, Rogowski, Kaminski, Wozniak, Benczkowski, Meyers

IV. Resolutions



1. RESOLUTION 2014-292

Warrant

Sponsored By: Supervisor Holtz, Councilmember Kaminski

BE IT RESOLVED, that the following Vouchers & Warrants submitted to the Town of Cheektowaga prior to May 19, 2014 are hereby approved and made part hereof;

GENERAL FUND	\$4,431,196.65
RISK RETENTION FUND	1,171,071.51
NYS HOME PROGRAM DEBT	
HUD HOUSING REHABILITATION FUND	9,650.00
SPECIAL DISTRICTS FUND	1,053,591.63
HIGHWAY FUND	891,181.11
CAPITAL FUND	157,728.46
TRUST & AGENCY FUND	167,423.33
HUD CDBG FUND	3,032.65
PART TOWN FUND	6,433.82
NYS AFFORDABLE HOUSING	138,155.11
	<hr/>
	\$8,029,464.27

RESULT:	ADOPTED [UNANIMOUS]
MOVER:	Mary Holtz, Supervisor
SECONDER:	Gerald Kaminski, Councilmember
AYES:	Holtz, Rogowski, Kaminski, Wozniak, Benczkowski, Meyers



2. RESOLUTION 2014-293

Approval of Change Order No. 1 - Installation of Replacement Variable Frequency Drives and Associated Motor Control System Modifications at the Main Pump Station

Sponsored By: Councilmember Meyers, Supervisor Holtz

WHEREAS, by resolution dated May 6, 2013 this Town Board awarded a contract for the Installation of Replacement Variable Frequency Drives and Associated Motor Control System Modifications at the Main Pump Station, including the Base Bid and Bid Alternate A in the total amount of \$780,000.00 to Ferguson Electric Construction Company, Inc., AND

WHEREAS, the original bid specifications also included Alternate Bid Item B for the replacement of Bar Screen Grinder #1 and #2 and associated work, which Alternate B was not awarded, AND

WHEREAS, Nussbaumer & Clarke, Inc., Project Engineer, the Town Engineer and the Superintendent of the Main Pump Station have recommended approval of Change Order No. 1 for the aforesaid project which provides for the total removal of the two (2) existing grinder units in their entirety, and replacement with modern grinders and also provides for control upgrades and an extension of 120 days for construction contract completion, all of which is detailed in the Change Order No. 1 document dated May 9, 2014, NOW, THEREFORE, BE IT

RESOLVED, that Change Order No. 1 for the aforementioned project in the amount of \$149,183.10 as an addition to the contract of Ferguson Electric Construction Company, Inc., 333 Ellicott Street, Buffalo, New York 14203 be and hereby is approved, AND, BE IT FURTHER

RESOLVED, that the Supervisor is hereby authorized and directed to execute said Change Order No. 1 on behalf of this Town Board, chargeable to Account #500-1440-2062-5228.

RESULT:	ADOPTED [UNANIMOUS]
MOVER:	Timothy J. Meyers, Councilmember
SECONDER:	Mary Holtz, Supervisor
AYES:	Holtz, Rogowski, Kaminski, Wozniak, Benczkowski, Meyers



3. RESOLUTION 2014-294

Amend Resolution 2013-564 - Approve Upgrade of and Maintenance Agreement for Town Telephone System

Sponsored By: Supervisor Holtz, Councilmember Kaminski

WHEREAS, by Resolution 2013-564, adopted November 4, 2013, this Town Board authorized the purchase of an upgrade to the Town's telephone system and related maintenance; and

WHEREAS, it is necessary to amend said Resolution to include the purchase of two (2) PRI Gateways for the sum of \$2,300.00 to provide for the automatic transfer of the 911 Administration lines and Fax lines in the event of a system failure, which, if purchased with the upgrade set forth in said resolution, will save the Town the cost of installation and configuration; NOW, THEREFORE, BE IT

RESOLVED, that Resolution 2013-564, adopted November 4, 2013, be and hereby is amended to include the following provision:

"RESOLVED, that this Town Board hereby approves the purchase of two (2) PRI Gateways from nexaComm for the sum of \$2,300.00, to provide for the automatic transfer of the 911 Administration lines and Fax lines in the event of a system failure; and BE IT FURTHER..."

and BE IT FURTHER

RESOLVED, that the second and third "RESOLVED" paragraphs be and hereby are amended to read as follows:

"RESOLVED, that the Supervisor be and hereby is authorized and directed to execute any and all documents necessary to effectuate the aforementioned purchase, upgrade and maintenance agreement, and BE IT FURTHER

RESOLVED, that the total cost of said upgrade, maintenance, and equipment, \$28,490.00, shall be appropriated from budget line item number 100-1625-4205."

RESULT:	ADOPTED [UNANIMOUS]
MOVER:	Mary Holtz, Supervisor
SECONDER:	Gerald Kaminski, Councilmember
AYES:	Holtz, Rogowski, Kaminski, Wozniak, Benczkowski, Meyers



4. RESOLUTION 2014-295

Accept Site Plan- 3035 Union Road Niagara Metals, LLC.

Sponsored By: Councilmember Benczkowski, Councilmember Rogowski

WHEREAS, pursuant to the Zoning Law of the Town of Cheektowaga, the Planning Board reviews various development review applications for site plans, rezonings, special permits and realty subdivisions and renders its recommendation concerning the compatibility of such application with the zoning regulations, the Town Master Plan and neighborhood character, AND

WHEREAS, the Town Board, pursuant to section 260-47.1C of the Zoning Law of the Town of Cheektowaga is vested with the authority to approve site plans and modify or reject any recommendation submitted to it by its advisory committees, AND

WHEREAS, Niagara Metals, LLC submitted a development review application for the re-development of an existing lawful non conforming salvage yard to a permit the construction of a new salvage/recycling facility including a new 15,000 s.f. processing building, a 450 s.f car dismantling building and two truck scales, AND

WHEREAS, the Town of Cheektowaga Zoning Board of Appeals is considering a use variance request to permit the existing lawful non conforming salvage yard to continue, AND

WHEREAS, the Cheektowaga Zoning Board of Appeals decision on the Use Variance request is still pending, AND

WHEREAS, the Town of Cheektowaga Planning Board, reviewed and commented on the application at their meeting of April 10, 2014 and have recommended approval thereof, NOW THEREFORE BE IT,

RESOLVED, that pursuant to Section 260-47-1 of the Code of the Town of Cheektowaga and Section 274-a of New York State Town Law that this Town Board approves the proposed site plan subject to the following:

1. The Zoning Board of Appeals granting the necessary Use Variance, or making a determination that a Use Variance is not required.
2. The Town Engineer reviewing and approving the grading/drainage plan.
3. The existing billboard sign being removed no later than the year 2032.
4. Any storage tanks used to store petroleum products must meet the National Fire Protection Association standards.
5. All exterior lighting shall be dark sky compliant.

RESULT:	ADOPTED [UNANIMOUS]
MOVER:	Diane Benczkowski, Councilmember
SECONDER:	James P. Rogowski, Councilmember
AYES:	Holtz, Rogowski, Kaminski, Wozniak, Benczkowski, Meyers



5. RESOLUTION 2014-296

Accept Site Plan- 432 Dingens Street Sunoco, Inc.

Sponsored By: Councilmember Benczkowski, Councilmember Rogowski

WHEREAS, pursuant to the Zoning Law of the Town of Cheektowaga, the Planning Board reviews various development review applications for site plans, rezonings, special permits and realty subdivisions and renders its recommendation concerning the compatibility of such application with the zoning regulations, the Town Master Plan and neighborhood character, AND

WHEREAS, the Town Board, pursuant to section 260-47.1C of the Zoning Law of the Town of Cheektowaga is vested with the authority to approve site plans and modify or reject any recommendation submitted to it by its advisory committees, AND

WHEREAS, Bergman Associates on behalf of Sunoco, Inc. submitted a development review application for the rezoning of 432 Dingens Street from C- Retail Business to MS- Motor Services, to permit the redevelopment of an existing gas station/convenience store, AND

WHEREAS, the proposed redevelopment project will involve the demolition of the existing convenient store and gasoline canopy structures located within the Town of Cheektowaga, and the construction of a new canopy within the Town of Cheektowaga and a new 3,520 s.f. store building within the City of Buffalo, AND

WHEREAS, the subject project requires area variances from the Cheektowaga Zoning Board of Appeals for the fueling island canopy location and parking setbacks, AND

WHEREAS, a zoning board of appeals application is pending before The Cheettowaga Zoning Board of Appeals for the required area variances, AND

WHEREAS, the Town of Cheektowaga Planning Board, reviewed and commented on the Application at their meeting of February 13, 2014 and have recommended approval thereof, NOW THEREFORE BE IT,

RESOLVED, that pursuant to Section 260-47-1 of the Code of the Town of Cheektowaga and Section 274-a of New York State Town Law that this Town Board approves the proposed site plan subject to:

1. The Town Engineer reviewing/approving the grading drainage plan.
2. The edge of pavement along the north property line be increased to a minimum of (15) fifteen feet.
3. A revised landscaping plan be presented to the Planning Board
4. The Planning Board Approve the Final Design of the Canopy

RESULT:	ADOPTED [UNANIMOUS]
MOVER:	Diane Benczkowski, Councilmember
SECONDER:	James P. Rogowski, Councilmember
AYES:	Holtz, Rogowski, Kaminski, Wozniak, Benczkowski, Meyers



6. RESOLUTION 2014-297

Approval of Rezoning of 432 Dingens Street

Sponsored By: Councilmember Benczkowski, Councilmember Meyers

WHEREAS, Sunoco, Inc. (R & M) petitioned for a rezoning from C-Retail Business District to MS-Motor Services District for property owned by it and located at 432 Dingens Street, Cheektowaga, New York, which property is described in the attached legal description, for the re-development of an existing lawful non-conforming gas station and convenience store, and

WHEREAS, public hearings on such petition were held before this Town Board on the 21st day of April, 2014 at 6:45 P.M., and on the 5th day of May, 2014 at 6:54 P.M. after publication and service of the notices required by the provisions of the Code of the Town of Cheektowaga ("Zoning Law"), and the Town Law; and all interested parties were given an opportunity to be heard at such hearing, and

WHEREAS, the Cheektowaga Planning Board has reviewed such application and has recommended approval thereof, and

WHEREAS, this Town Board previously issued a Negative Declaration under SEQRA and the Town Environmental Impact Review Ordinance for this rezoning, NOW, THEREFORE, BE IT

RESOLVED, that the application of Sunoco, Inc. (R & M) for the rezoning from C-Retail Business District to MS-Motor Services District of the property described in the attached legal description for the re-development of an existing lawful non-conforming gas station and convenience store be and the same is hereby approved, and BE IT FURTHER

RESOLVED, that any future additions to the development or site plan must be resubmitted to the Town Board to determine whether the addition is substantially in agreement with the intent of this rezoning and site plan approval, and BE IT FURTHER

RESOLVED, that the Zoning Map and Law of the Town Of Cheektowaga be amended in accordance with the above.



LEGAL DESCRIPTION

All that tract or parcel of land situate in Town of Cheektowaga, County of Erie, and State of New York, being known as Subdivision Lots 3 and 4 as shown on a map entitled "Shanley Street Extension Subdivision Plat", part of Farm Lots 147 and 148, Township 10 and Range 7, Holland Land Company, filed in the Erie County Clerk's Office on October 9, 1952 under Map cover 1791, and being more particularly bounded and described as follows:

Beginning at the point of intersection of the westerly line of Shanley Street (60 feet wide) and the northerly line of Dingens Street (73.5 feet wide); thence, North 81°13'45" West, on the

northerly line of said Dingens Street, a distance of 118.43 feet to a rebar found on the division line between the City of Buffalo on the west and the Town of Cheektowaga on the east; thence, North 08°25'50" East, on said division line, a distance of 118.61 feet to a point; thence, South 81°30'00" East, a distance of 118.57 feet to a point of the westerly line of said Shanley Street; thence, South 08°30'00" West, on the westerly line of said Shanley Street, a distance of 119.17 feet to the Point of Beginning. Said parcel containing 0.323 acres, more or less, described as Parcel A as filed in Book 9519 of Deeds, Page 551 in the Erie County Clerk's Office, and as shown on a map prepared by Bergmann Associates entitled "Property Map Sunoco, Inc., 422, 424, 428 & 432 Dingens Street", drawing number CM-1, dated August 26, 2013, last revised on September 30, 2013, said map to be filed in the Erie County Clerk's Office.

RESULT:	ADOPTED [UNANIMOUS]
MOVER:	Diane Benczkowski, Councilmember
SECONDER:	Timothy J. Meyers, Councilmember
AYES:	Holtz, Rogowski, Kaminski, Wozniak, Benczkowski, Meyers



7. RESOLUTION 2014-298

Adopt Local Law No. 2 of 2014 - A Local Law to Amend the Taxicabs Law

Sponsored By: Councilmember Benczkowski, Councilmember Rogowski

WHEREAS, Chapter 23 of the Code of the Town of Cheektowaga, entitled "Taxicabs" was adopted by the Town Board on October 21, 1985, and

WHEREAS, said law requires anyone who operates a taxicab or similar vehicle-for-hire to obtain a permit from the Town Clerk and to otherwise comply with the other provisions of said law, and

WHEREAS, the Town Clerk and Police Department have recommended that this law be repealed and that a new Taxicabs Law be enacted, and

WHEREAS, on November 18, 2013, a public hearing was held on proposed Local Law Intro No. 2013-4 of the Year 2013, entitled "A Local Law to Amend the Taxicabs Law", and

WHEREAS, after said public hearing, changes were made to said proposed local law, and

WHEREAS, in accordance with the provisions of the Town Law/Municipal Home Rule Law of the State of New York, a public hearing was held on the 5th day of May, 2014 at 6:45 P.M. at the Town Hall, 3301 Broadway, Cheektowaga, New York, at which hearing all interested parties were given an opportunity to be heard as to whether Local Law Intro No. 2014-2 of the Year 2014 entitled "A Local Law to Amend the Taxicabs Law" should be enacted, and

WHEREAS, it is in the public interest to adopt said local law, NOW, THEREFORE, BE IT

RESOLVED, that the existing Taxicabs Law (Chapter 223 of the Code of the Town of Cheektowaga) be and hereby is repealed, effective upon the filing of Local Law No. 2 of the Year 2014 with the Secretary of State, and BE IT FURTHER

RESOLVED, that Local Law No. 2 of the Year 2014, entitled "A Local Law to Amend the Taxicabs Law", which is attached hereto and made a part hereof, be and the same is hereby enacted, and BE IT FURTHER

RESOLVED, that Local Law No. 2 of the Year 2014 shall be effective on July 1, 2014, after filing with the Secretary of State, and BE IT FURTHER

RESOLVED, that the Town Clerk shall file one (1) certified copy of this local law in her office and one (1) certified copy with the Secretary of State.

Attachments:

Adopt LL 2-2014 Taxi Cab Chapter (rev 5-12-14) (DOC)

RESULT: **ADOPTED [UNANIMOUS]**
MOVER: Diane Benczkowski, Councilmember
SECONDER: James P. Rogowski, Councilmember
AYES: Holtz, Rogowski, Kaminski, Wozniak, Benczkowski, Meyers



8. RESOLUTION 2014-299

Adopt Amendment to Parks Ordinance

Sponsored By: Councilmember Rogowski, Councilmember Wozniak

WHEREAS, the Town of Cheektowaga previously adopted a Parks Ordinance (Chapter 174 of the Code of the Town of Cheektowaga) with amendments thereto, and Rules and Regulations governing Cheektowaga Town Parks which apply to Town parks and public park approaches owned by the Town of Cheektowaga, and

WHEREAS, the Cheektowaga Cultural Center in Cheektowaga Town Park is a venue for various concerts and events; oftentimes people sit and stand in close proximity to each other in the Cultural Center area (which includes the fenced in area around the Cultural Center and the Lion's Pavilion), and

WHEREAS, in the past, complaints have been registered by people utilizing the Cultural Center about smokers and smoking in the Cultural Center, and

WHEREAS, in accordance with the provisions of Section 130 of the Town Law of the State of New York, a public hearing was held on the 19th day of May, 2014 at 6:45 P.M. at a meeting of the Town Board at the Cheektowaga Town Hall, 3301 Broadway, Cheektowaga, New York 14227, at which hearing all parties in interest and citizens had an opportunity to be heard as to whether Chapter 174 of the Code of the Town of Cheektowaga ("Parks Ordinance") should be amended as provided in the Notice of Hearing, and

WHEREAS, this Board feels that it is in the best interests of the Town residents and taxpayers that smoking be prohibited in the Cultural Center area, NOW, THEREFORE, BE IT

RESOLVED, that the Parks Ordinance (Chapter 174) of the Code of the Town of Cheektowaga be and hereby is amended as follows:

A new Section 174-7.1 of the Parks Ordinance shall be added to read as follows:

Section 174-7.1. Smoking within Cheektowaga Cultural Center prohibited.

Smoking shall be prohibited and no person shall smoke within the area (inside and outside any buildings) designated as the Cheektowaga Cultural Center. The Cheektowaga Cultural Center shall include the stage area, the bleachers, seating areas and the land within the fenced-in area around the Cultural Center (including the Lion's Pavilion/mega-shelter). For purposes of this law, "smoking" means the burning of a lighted cigar, cigarette, pipe or other matter or substance which contains tobacco.

, and BE IT FURTHER

RESOLVED, that a copy of this resolution be entered in the minutes of the meeting of the Town Board of the Town of Cheektowaga held on the 19th day of May, 2014, and that a certified copy hereof be published in the CHEEKTOWAGA BEE, the official Town newspaper, and BE IT FURTHER

RESOLVED, that this amendment shall become effective after publishing and posting as

required by statute.

RESULT:	ADOPTED [UNANIMOUS]
MOVER:	James P. Rogowski, Councilmember
SECONDER:	Angela M. Wozniak, Councilmember
AYES:	Holtz, Rogowski, Kaminski, Wozniak, Benczkowski, Meyers



9. RESOLUTION 2014-300

Award of Bid - Sewer Maintenance Building Addition and Renovations (Bid #2014-11)

Sponsored By: Supervisor Holtz, Councilmember Meyers

WHEREAS, a Notice to Bidders was published for the receipt of bids for the Sewer Maintenance Building Addition and Renovations Project, which bids were duly received and opened by the Town Clerk on March 26, 2014, AND

WHEREAS, said bids were referred to the Project Architect and the Town Engineer for analysis, tabulation and report, which is contained in a letter from the Engineering Department dated May 14, 2014, AND

WHEREAS, said letter recommends that the contract for the construction of the Sewer Maintenance Building Addition and Renovations be awarded to S.M. Hayes, LLC, Construction Services, for their submission of the lowest bid meeting the requirements of the specifications, NOW, THEREFORE, BE IT

RESOLVED, that the bid for the construction of the Sewer Maintenance Building Addition and Renovations be and hereby is awarded to:

SM Hayes, LLC
Construction Services
174 Anderson Place
Buffalo, New York 14222

for their total bid price of \$506,900.00, said bid being the lowest bid meeting the requirements of the specifications and construction drawings, AND, BE IT FURTHER

RESOLVED, that the Supervisor, on behalf of this Town Board, be and hereby is directed and authorized to execute the contract with SM Hayes, LLC for the aforesaid project, AND, BE IT FURTHER

RESOLVED, that funding for said project shall be chargeable to Account #500-1440-2366-5325.

RESULT:	ADOPTED [UNANIMOUS]
MOVER:	Mary Holtz, Supervisor
SECONDER:	Timothy J. Meyers, Councilmember
AYES:	Holtz, Rogowski, Kaminski, Wozniak, Benczkowski, Meyers



10. RESOLUTION 2014-301

Award of Bid - Reroofing the Senior Citizen's Center (Bid #2014-23)

Sponsored By: Supervisor Holtz, Councilmember Kaminski

WHEREAS, a Notice to Bidders was published for the receipt of bids for Reroofing the Senior Citizen's Center (Bid 2014-23), which bids were duly received and opened by the Town Clerk on May 14, 2014, AND

WHEREAS, said bids were referred to the Town Engineer for analysis, tabulation and report, which is contained in a letter from the Engineering Department dated May 15, 2014, AND

WHEREAS, said letter recommends that the contract for the Reroofing of the Senior Citizen's Center be awarded to Tschetter's Construction Corporation for their submission of the lowest bid meeting the requirements of the specifications, NOW, THEREFORE, BE IT

RESOLVED, that the bid for the Reroofing of the Senior Citizen's Center be and hereby is awarded to:

Tschetter's Construction Corporation
4560 Clinton Street
West Seneca, New York 14224

for their total bid price of \$148,412.00, said bid being the lowest bid meeting the requirements of the specifications and construction drawings, AND, BE IT FURTHER

RESOLVED, that the Supervisor, on behalf of this Town Board, be and hereby is directed and authorized to execute the contract with Tschetter's Construction Corporation for the aforesaid project, AND, BE IT FURTHER

RESOLVED, that funding for said project shall be chargeable to Account #500-7620-9508-5329.

RESULT:	ADOPTED [UNANIMOUS]
MOVER:	Mary Holtz, Supervisor
SECONDER:	Gerald Kaminski, Councilmember
AYES:	Holtz, Rogowski, Kaminski, Wozniak, Benczkowski, Meyers



11. RESOLUTION 2014-302

Award Summer Camp Busing 2014

Sponsored By: Councilmember Wozniak, Councilmember Rogowski

WHEREAS, in accordance with the policies and procedures adopted by the Cheektowaga Town Board for the procurement of goods and services, the Department of Youth and Recreational Services solicited proposals for transportation for its 2014 summer camp programs, AND

WHEREAS, proposals were received for the provision of said bus transportation services, AND

WHEREAS, First Student, Inc. has submitted the lowest responsible quotation for the provision of bus transportation services, NOW, THEREFORE, BE IT

RESOLVED that this Town Board hereby awards the contract for the provision of bus transportation at a cost of \$8,790.00 for the Department of Youth & Recreational Services' day camp programs to:

--First Student Inc.
45 Anderson Road
Cheektowaga, New York 14225

Line Item Nos.: 7140.4517
7140.4518

RESULT:	ADOPTED [UNANIMOUS]
MOVER:	Angela M. Wozniak, Councilmember
SECONDER:	James P. Rogowski, Councilmember
AYES:	Holtz, Rogowski, Kaminski, Wozniak, Benczkowski, Meyers



12. RESOLUTION 2014-303

Call for Public Hearing to Amend Landlord Licensing Law

Sponsored By: Supervisor Holtz, Councilmember Kaminski

WHEREAS, the rental of residential dwellings is a business, and

WHEREAS, on March 4, 2013, the Town Board adopted Local Law No. 1 of the Year 2013 entitled "A Local Law Relating to Landlord Licensing", and

WHEREAS, there is a need to amend this local law to also require the licensing of landlords who rent out one-family, two-family and three-family dwelling units (excluding only owner-occupied 1-, 2-, and 3-family dwellings), and

WHEREAS, an amendment to the Landlord Licensing Law has been drafted to accomplish this purpose, NOW, THEREFORE, BE IT

RESOLVED, that, in accordance with the provisions of the Town Law/Municipal Home Rule Law of the State of New York, a public hearing shall be held on the 2nd day of June, 2014 at 6:45 P.M. at a meeting of the Town Board at the Cheektowaga Town Hall, 3301 Broadway, Cheektowaga, New York; at which hearing all interested parties will be given an opportunity to be heard and at which time and place it may be determined by the Town Board whether Local Law Intro No. 2014-3 of the Year 2014, entitled "A Local Law to Amend the Landlord Licensing Law" should be enacted, and BE IT FURTHER

RESOLVED, that the Town Clerk shall publish the attached Notice of Hearing in the CHEEKTOWAGA BEE, the official Town newspaper.



LEGAL NOTICE

NOTICE IS HEREBY GIVEN that a public hearing will be held by the Town Board of the Town of Cheektowaga, Erie County, New York at the Town Hall, 3301 Broadway, Cheektowaga, New York, on the 2nd day of June, 2014 at 6:45 P.M. on said day for the purpose of considering the adoption of Local Law Intro No. 2014-3 of the Year 2014, entitled "A

Local Law to Amend the Landlord Licensing Law". A summary of such Local Law is as follows:

LOCAL LAW INTRO NO. 2014-3 OF THE YEAR 2014

A LOCAL LAW TO AMEND THE LANDLORD LICENSING LAW

The purpose of this law is to expand the landlord licensing requirement to owners of one-family, two-family, and three-family rental properties to obtain a rental housing business license from the Town of Cheektowaga in order to lease their properties; owner-occupied one-, two- and three-family homes would be excepted from this amendment.

Also, this law would change the reporting year, from "calendar year" to "activity year" for criminal activity or public nuisance events which would be registered on the property; and for which the landlord can be fined.

A copy of the entire text of Local Law Intro No. 2014-3 is on file in the Town Clerk's Office, where the same may be viewed during regular business hours

BY ORDER OF THE TOWN BOARD OF THE TOWN OF CHEEKTOWAGA, ERIE COUNTY, NEW YORK.

Dated: May 19, 2014

ALICE MAGIERSK, Town Clerk

RESULT:	ADOPTED [UNANIMOUS]
MOVER:	Mary Holtz, Supervisor
SECONDER:	Gerald Kaminski, Councilmember
AYES:	Holtz, Rogowski, Kaminski, Wozniak, Benczkowski, Meyers



13. RESOLUTION 2014-304

Authorize Town Clerk to Issue New/Renewal Ambulance Drivers/Attendants Licenses

Sponsored By: Councilmember Meyers, Supervisor Holtz

WHEREAS, on the 7th day of May, 1984, this Town Board adopted an Ambulance Ordinance. The EMS Board, which was created at that time, has completed a review and evaluation of new/renewal license applications for driver(s)/attendant(s), and has recommended that the Town Board issue such licenses, NOW, THEREFORE BE IT

RESOLVED, that the recommendations of the EMS Board concerning the licensing of new/renewal driver(s)/attendant(s) shown on the list below be and hereby are accepted and approved, for a period to expire upon the expiration of such ambulance driver(s)/attendant(s) Emergency Medical Technician ('EMT') card and, BE IT FURTHER

RESOLVED, that the Town Clerk be and hereby is authorized, empowered and directed to issue new/renewal licenses to the driver(s)/attendant(s) set forth on the annexed schedule, pursuant to the terms of this resolution.

Name	Expiration Date
Avery, Steven C	11/30/2016
Bacon, Nicholas G.	7/31/2016
Baker, Kevin L	11/30/2016
Barnack, Joseph F.	3/31/2017
Bertino, Timothy	10/31/2014
Bluhm, Sara A	8/31/2016
Bosworth, Blaine D	6/30/2015
Boulet, Susannah C	9/30/2016
Cassick, Aaron J	1/31/2017
Clarke, Kenyon	9/30/2016
Collana, Luigi GM	1/31/2017
Daigler, Nathan A	3/31/2017
Day, Justin R	12/31/2016
Doran, Kathleen	2/29/2016
Faircloth, Shannon M	4/30/2017
Fisher, Patrick J	2/28/2017
Fredrickson, Jon B	9/30/2016
Galanis, Michael P	4/30/2015
Garbacz, Samantha	7/31/2016
Geary, Jack	7/31/2016
Gian, Michael J	7/31/2016
Gibbons, Jacob D	2/28/2017
Goldsmith, William	8/31/2016

Gorges, Elizibeth	9/30/2016
Grabowski, Adam N	3/31/2017
Gray, Catherine A.	12/31/2016
Hall, Patrick A	2/28/2017
Holt, James B	12/31/2016
Huber, Sara	2/28/2015
Igielinski, Daniel	3/31/2016
Ijaz, Abdullah	9/30/2015
Jackson, Nolin S	2/29/2016
Johnson, Sandra L	10/31/2016
Jordan, Arshaun N	3/31/2016
Jordan, Jacquelyn B	7/31/2016
Jurek, Matthew J.	4/30/2017
Kaszuba, Nicholas V	6/30/2016
Kruger, Ashley M	2/28/2017
Letourneau, Jean Marie	8/31/2016
Lines, Joel P	3/31/2015
Lockett, Antwan	2/28/2017
Luscher, Donald E Jr	12/31/2015
Maess, David A	12/31/2016
Marshall, Matthew E	7/31/2015
Meyer, Spencer L	10/31/2016
Mihans, Megan	9/30/2015
Miranto, Andreana	1/31/2017
Natalzia, Peter J	2/28/2017
Nowak, Brandon M	2/28/2017
Oldani, Peter	1/31/2016
Picart, Youzi I	11/30/2016
Piersa, Jacob T	9/30/2016
Porzio, Aaron L	9/30/2016
Potoczak, Lynne M	2/28/2017
Pratt, Joseph M	6/30/2015
Reynolds, Patrick W	3/31/2017
Schweickert, Alisha M	2/28/2017
Sheedy, Ryan M	8/31/2016
Smith, Eric D	1/31/2016
Smith, Jeffrey H	12/31/2016
Sporski, Daren M	3/31/2017
Stiith, Joel T	2/28/2017
Stoddard, Kyle M	3/31/2017
Suarez, Ramon	2/29/2016
Szczepaniak, Thomas D	11/30/2016
Taylor, Anthony W	9/30/2016
Taylor, Bethany D	1/31/2017
Tylenda, Ashley	7/31/2016
Wattie, Katharine E	2/28/2017
Wellspeak, Dennis R	12/31/2016

Wolff, Brian	3/31/2017
Yohe, Steven C	11/30/2016
Yusuf, Afshar A	4/30/2017

RESULT:	ADOPTED [UNANIMOUS]
MOVER:	Timothy J. Meyers, Councilmember
SECONDER:	Mary Holtz, Supervisor
AYES:	Holtz, Rogowski, Kaminski, Wozniak, Benczkowski, Meyers



14. RESOLUTION 2014-305

Approve Agreement with Captains and Lieutenants Association for 2014-2015

Sponsored By: Supervisor Holtz, Councilmember Kaminski

WHEREAS, the collective bargaining agreement between the Town of Cheektowaga and the Cheektowaga Captains and Lieutenants Association, Inc. expired on December 31, 2013, AND

WHEREAS, the Town and the Cheektowaga Captains and Lieutenants Association, Inc. have negotiated and have agreed upon a successor agreement for Years 2014 through 2015; NOW, THEREFORE, BE IT

RESOLVED, that the Town Board hereby accepts and approves the successor agreement with the Cheektowaga Captains and Lieutenants Association, Inc. for the term January 1, 2014 to December 31, 2015, as presented, and BE IT FURTHER

RESOLVED, that the Town Supervisor be and hereby is authorized to execute the respective collective bargaining agreement between the Town of Cheektowaga and the Cheektowaga Captains and Lieutenants Association, Inc.

RESULT:	ADOPTED [5 TO 0]
MOVER:	Mary Holtz, Supervisor
SECONDER:	Gerald Kaminski, Councilmember
AYES:	Holtz, Rogowski, Kaminski, Benczkowski, Meyers
ABSTAIN:	Angela M. Wozniak



15. RESOLUTION 2014-306

Authorize Supervisor to Execute License Agreement with Airlanes Jr. Football

Sponsored By: Councilmember Rogowski, Councilmember Wozniak

WHEREAS, the Town of Cheektowaga is the owner of a comfort station building located in the east portion of John C. Stiglmeier Park, and

WHEREAS, the southerly end of said comfort station building was formerly used as a concession/snack stand, but was vacant and unused for a few years, and

WHEREAS, Airlanes Junior Football of Cheektowaga, Inc. was granted a license by this Town Board in 2013 to operate a concession/snack stand in 2013 at this comfort station building, and

WHEREAS, Airlanes Junior Football of Cheektowaga, Inc. requested permission to utilize this portion of the comfort station building for a concession/snack stand in 2014 and 2015 and has offered to donate 75% of the proceeds from the sale of food and beverage to the Town Stiglmeier Park Steering Committee Comfort Station Fund, and

WHEREAS, the Town Attorney has prepared a license agreement to permit the use of this portion of the comfort station building to the Airlanes Junior Football of Cheektowaga, Inc. For 2014 and 2015, NOW, THEREFORE, BE IT

RESOLVED, that the Supervisor be and hereby is authorized and directed to execute this license agreement on behalf of the Town.

RESULT:	ADOPTED [UNANIMOUS]
MOVER:	James P. Rogowski, Councilmember
SECONDER:	Angela M. Wozniak, Councilmember
AYES:	Holtz, Rogowski, Kaminski, Wozniak, Benczkowski, Meyers



16. RESOLUTION 2014-307

Authorize Supervisor to Sign Agreement with Aurora Architectural Design, P.C. for the Sewer Maintenance Building Addition and Renovations

Sponsored By: Supervisor Holtz, Councilmember Kaminski

WHEREAS, the contract to construct a Building Addition and Renovations to the Town of Cheektowaga Sewer Maintenance Building has been awarded by resolution dated May 19, 2014, AND

WHEREAS, there is a need to perform professional construction phase services throughout the duration of this project and the firm of Aurora Architectural Design, P.C., Project Architect, has submitted a proposal for professional services for the aforesaid project, NOW, THEREFORE, BE IT

RESOLVED, that the firm of Aurora Architectural Design, P.C., 1051 Olean Road, East Aurora, New York 14052 be retained for the provision of professional services at a cost not to exceed \$15,800.00 in accordance with the proposal dated November 15, 2013, AND BE IT FURTHER

RESOLVED, that the Supervisor, on behalf of this Town Board, is hereby directed and authorized to sign said agreement with Aurora Architectural Design, P.C. in an amount not to exceed the sum of \$15,800.00, chargeable to Account #500-1440-4225-5325.

RESULT:	ADOPTED [UNANIMOUS]
MOVER:	Mary Holtz, Supervisor
SECONDER:	Gerald Kaminski, Councilmember
AYES:	Holtz, Rogowski, Kaminski, Wozniak, Benczkowski, Meyers



17. RESOLUTION 2014-308

Authorize Supervisor to Execute Sub Recipient Agreements for FY 2013-2014

Sponsored By: Councilmember Benczkowski, Supervisor Holtz

WHEREAS, Community Development Block Grant Funds have been budgeted for various activities as outlined in the Annual Action Plan, AND

WHEREAS, the Town of Cheektowaga has entered into agreements with various villages and not-for-profits to carry out the activities specified in the Annual Action Plan, AND

WHEREAS, the Director of Community Development has recommended that the Town execute said agreements for 2013 - 2014 not to exceed the amounts outlined in the Annual Action Plan, NOW THEREFORE BE IT

RESOLVED, that the Supervisor be and hereby is authorized and directed to execute the 2013 - 2014 agreements with the Villages of Depew and Sloan, as well as Belmont Housing Resources for WNY, Child & Family Services, and Supportive Services, AND BE IT

FURTHER RESOLVED, that said programs be funded with Community Development Block Grant funds.

RESULT:	ADOPTED [UNANIMOUS]
MOVER:	Diane Benczkowski, Councilmember
SECONDER:	Mary Holtz, Supervisor
AYES:	Holtz, Rogowski, Kaminski, Wozniak, Benczkowski, Meyers



18. RESOLUTION 2014-309

Authorize the Supervisor to Execute the Supplemental Professional Technical Services Proposal with Nussbaumer & Clarke, Inc.

Sponsored By: Councilmember Meyers, Supervisor Holtz

WHEREAS, by resolution dated July 1, 2013 this Town Board engaged the firm of Nussbaumer & Clarke, Inc. to perform construction phase services for the Installation of Replacement Variable Frequency Drive and Associated Motor Control Systems Modification Project at the Main Pump Station, AND

WHEREAS, there is a need to extend and supplement the scope of professional services during construction for the aforesaid project as the complexity of this project requires additional site visits, testing, inspection, meetings and coordination of construction procedures to insure uninterrupted facility operation as outlined in a letter dated May 9, 2014 from Nussbaumer & Clarke, Inc. to the Town Engineer and Superintendent of the Main Pump Station, NOW, THEREFORE, BE IT

RESOLVED, that the Supervisor, on behalf of this Town Board, is hereby directed and authorized to execute the Supplemental Professional Technical Services During Construction Proposal with Nussbaumer & Clarke, Inc. dated May 9, 2014 in an amount not to exceed \$29,000.00, chargeable to Account No. 500-1440-2062-5228.

RESULT:	ADOPTED [UNANIMOUS]
MOVER:	Timothy J. Meyers, Councilmember
SECONDER:	Mary Holtz, Supervisor
AYES:	Holtz, Rogowski, Kaminski, Wozniak, Benczkowski, Meyers



19. RESOLUTION 2014-310

Authorize Supervisor to Sign Agreement with O'Connell Electric Company, Inc. for Photovoltaic System Inspection and Maintenance

Sponsored By: Supervisor Holtz, Councilmember Rogowski

WHEREAS, the Town operates four (4) solar energy photovoltaic rooftop systems located at the Town Hall, Highway Garage, Facilities Maintenance Garage and at the Main Pump Station, AND

WHEREAS, in order to ensure optimal system performance and energy output, minimize disruptions and to ensure that the equipment and system components perform as required, the Town Engineer has recommended that the Town renew a Preventative Maintenance Contract, NOW, THEREFORE, BE IT

RESOLVED, that the proposal of O'Connell Electric Company, Inc., 830 Phillips Road, Victor, New York 14564, dated May 1, 2014 for photovoltaic system inspection and maintenance, deviation alert monitoring and solar module cleaning to renew on June 1, 2014 and end on May 31, 2015 is accepted and approved, AND, BE IT FURTHER

RESOLVED, that the Supervisor, on behalf of this Town Board, is hereby directed and authorized to sign the agreement with O'Connell Electric Company, Inc., and the fee per site in the amount of \$1,250.00 shall be chargeable to the following utility accounts:

Highway	100-5132-4211
Facilities	100-7110-4217
Town Hall	100-1625-4217
Main Pump Station	255-8135-4217

RESULT:	ADOPTED [UNANIMOUS]
MOVER:	Mary Holtz, Supervisor
SECONDER:	James P. Rogowski, Councilmember
AYES:	Holtz, Rogowski, Kaminski, Wozniak, Benczkowski, Meyers



20. RESOLUTION 2014-311

Purchase of One (1) License Plate Reader

Sponsored By: Councilmember Benczkowski, Councilmember Kaminski

WHEREAS, the Cheektowaga Police Department wishes to purchase one (1) mobile License Plate Reader, AND

WHEREAS, they currently own and operate eight (8) mobile and one (1) stationary License Plate Readers, AND

WHEREAS, the system, which typically captures over 800 license plates in an eight (8) hour period, has the ability to read all license plates, advise the police officer if a vehicle is stolen, the registration is suspended and the registered owner has a warrant, AND

WHEREAS, ELSAG North America, LLC, 205-H Creek Ridge Road, Greensboro, North Carolina 27406 offers New York State Contract pricing under Contract #PC62119 for the purchase of the License Plate Reader, AND

WHEREAS, the total cost for the one (1) License Plate Reader is \$21,087.50, AND

WHEREAS, the Cheektowaga Police Department will pay for said License Plate Reader out of the Police Asset Forfeiture Line #600-0600-0881, NOW, THEREFORE, BE IT

RESOLVED, that the Cheektowaga Town Board hereby authorizes the Cheektowaga Police Department to purchase the one (1) License Plate Reader.

RESULT:	ADOPTED [UNANIMOUS]
MOVER:	Diane Benczkowski, Councilmember
SECONDER:	Gerald Kaminski, Councilmember
AYES:	Holtz, Rogowski, Kaminski, Wozniak, Benczkowski, Meyers



21. RESOLUTION 2014-312

Authorize Purchase of One (1) Throwbot XT Tactical Robot

Sponsored By: Councilmember Benczkowski, Councilmember Kaminski

WHEREAS, the Cheektowaga Police Department wishes to purchase one (1) Throwbot XT Tactical Robot, AND

WHEREAS, the Throwbot XT Tactical Robot is a man portable, remote controlled robot designed to provide immediate video surveillance to law enforcement personnel in hostile environments while limiting exposure of officers to immediate hazards, AND

WHEREAS, Recon Robotics, 7620 West 78th Street, Minneapolis, MN 55439 has been approved as a sole source provider of the Throwbot XT Tactical Robot, AND

WHEREAS, the total cost for one (1) Throwbot XT Tactical Robot is \$13,771.99, AND

WHEREAS, the Cheektowaga Police Department will pay for said Throwbot XT Tactical Robot out of the Police Asset Forfeiture Line #600-0600-0881, NOW, THEREFORE, BE IT

RESOLVED, that the Cheektowaga Town Board hereby authorizes the Cheektowaga Police Department to purchase one (1) Throwbot XT Tactical Robot.

RESULT:	ADOPTED [UNANIMOUS]
MOVER:	Diane Benczkowski, Councilmember
SECONDER:	Gerald Kaminski, Councilmember
AYES:	Holtz, Rogowski, Kaminski, Wozniak, Benczkowski, Meyers



22. RESOLUTION 2014-313

Authorize Purchase of Computer Equipment Under New York State Office of General Services Contract

Sponsored By: Supervisor Holtz, Councilmember Kaminski

WHEREAS, the Town of Cheektowaga's current telephone routers and the main network switch at Town Hall are approaching the end of their functional use and product support; AND

WHEREAS, the Town needs to replace said equipment and related software; AND

WHEREAS, a local vendor, Inergex, Inc., 50 Fountain Plaza, Buffalo, New York, was awarded the New York State Office of General Services Contract (Contract PT64525, Group 77018, Award 21350) for the required equipment, software, and support, and has submitted proposals to the Town for a total price of \$120,201.80, same being New York State contract pricing; AND

WHEREAS, funding for said computer equipment is available from Information Services budget line item number 100.1680.2204; NOW, THEREFORE, BE IT

RESOLVED, that this Town Board hereby accepts the proposals of INERGEX, INC., and authorizes the purchase of the aforementioned equipment, software, and product support from:

INERGEX, INC.
50 Fountain Plaza, Ste. 700
Buffalo, New York 14201

in accordance with their proposal dated 4/28/2014 (Cisco 3945 Integrated Services Router and related equipment, software and yearly hardware maintenance) in the amount of \$43,372.60 (Town Hall and Alexander Street); the proposal dated 4/28/2014 (Cisco 3945 Services Router and related equipment, software and yearly hardware maintenance) in the amount of \$19,231.50 (Police Station); and the proposal dated May 1, 2014 in the amount of \$57,597.70, for a total cost of \$120,201.80; and be it FURTHER

RESOLVED, that funding for said equipment, software, and support shall be appropriated from budget line item number 100.1680.2204; AND BE IT FURTHER

RESOLVED, that the Supervisor be and hereby is authorized and directed to execute all documents necessary to effectuate the purchase of the aforementioned equipment.

RESULT:	ADOPTED [UNANIMOUS]
MOVER:	Mary Holtz, Supervisor
SECONDER:	Gerald Kaminski, Councilmember
AYES:	Holtz, Rogowski, Kaminski, Wozniak, Benczkowski, Meyers



23. RESOLUTION 2014-314

NYSDEC Year 11 Annual Report

Sponsored By: Supervisor Holtz, Councilmember Kaminski

WHEREAS, a SPDES General Permit for Stormwater Discharges from Municipal Separate Stormwater Sewer Systems (MS4's) was issued to the Town of Cheektowaga by the New York State Department of Environmental Conservation (NYSDEC), which permit requires the Town to conduct a Stormwater Management Program designed to reduce the discharge of pollutants from storm sewer systems, AND

WHEREAS, the Year 11 Annual Report of activities completed to achieve measurable goals is required to be submitted to the NYSDEC following the receipt of public comment not later than June 1, 2014, AND

WHEREAS, the Annual Report has been prepared by the Town Engineer and is available for review and comment in the Office of the Town Engineer, NOW, THEREFORE, BE IT

RESOLVED, that public comment on the subject Annual Report shall be received until May 28, 2014 for inclusion in the final report to be submitted to the NYSDEC, AND, BE IT FURTHER

RESOLVED, that the Supervisor is hereby authorized to execute the Municipal Compliance Certification Form for submission to the NYSDEC with the Year 11 Annual Report.

RESULT:	ADOPTED [UNANIMOUS]
MOVER:	Mary Holtz, Supervisor
SECONDER:	Gerald Kaminski, Councilmember
AYES:	Holtz, Rogowski, Kaminski, Wozniak, Benczkowski, Meyers



24. RESOLUTION 2014-315

Approve Cultural Group Funding for Various Cultural Groups

Sponsored By: Councilmember Rogowski, Supervisor Holtz

WHEREAS, the Town, in its 2014 budget, allocated moneys to certain cultural and not-for-profit organizations which are involved in activities which benefit the Town, and

WHEREAS, agreement(s) between the Town and these cultural and not-for-profit organizations have been prepared and forwarded to such groups, and

WHEREAS, the organization(s) listed below have completed and returned signed agreement(s) and their accounting report(s) from the 2013 funding to the Town, NOW, THEREFORE, BE IT

RESOLVED that this Town Board hereby approves agreement(s) with the cultural and not-for-profit organization(s) listed below for the amount(s) listed, and BE IT FURTHER

RESOLVED that the Supervisor be and hereby is authorized and directed to execute agreement(s) with the following referenced cultural and not-for-profit organization(s) for the following respective amount(s):

<u>Cultural/Not-For-Profit Organization</u>	<u>Funding Approved</u>
Cheektowaga Historical Association	\$3,050.00
Cheektowaga Garden Club	\$625.00

And BE IT FURTHER

RESOLVED that the aforementioned moneys shall be paid to the respective cultural/not-for-profit organization(s) out of the respective cultural group budget line item(s) in the 2014 Town budget, subject to audit and approval of a properly signed Town voucher.

RESULT:	ADOPTED [UNANIMOUS]
MOVER:	James P. Rogowski, Councilmember
SECONDER:	Mary Holtz, Supervisor
AYES:	Holtz, Rogowski, Kaminski, Wozniak, Benczkowski, Meyers



25. RESOLUTION 2014-316

Public Improvement Permit - East Side of Duke Road (Benderson Development Company, L.L.C.)

Sponsored By: Councilmember Kaminski, Councilmember Benczkowski

WHEREAS, the Public Improvement Permit Ordinance of the Town of Cheektowaga requires that all public improvements which are to be dedicated to and be maintained by the Town be installed under a Public Improvement Permit, AND

WHEREAS, the Benderson Development Company, L.L.C. has submitted plans and specifications, Public Improvement Permit Application, and permit fee for the installation of a large pre-cast concrete storm sewer chamber and twin 36" pipe to accommodate modifications to a Town maintained drainage system, enabling the creation of an access drive located on the east side of Duke Road, AND

WHEREAS, the Town Engineer has reviewed the plans and specifications for the subject improvements and finds said design acceptable, NOW THEREFORE, BE IT

RESOLVED, that the Public Improvement Permit be and hereby is approved for the aforesaid drainage system modifications, AND, BE IT FURTHER

RESOLVED, that the permit fee in the amount of \$1,440.00 be deposited in the Public Improvement Permit Account which has been established for receipt and disbursement of such fees, AND, BE IT FURTHER

RESOLVED, that a permanent drainage easement shall be granted to the Town in a form acceptable to the Town Attorney and Town Engineer for the portion of the stated improvements being constructed on private property beyond the limits of the Duke Road highway right-of-way.

RESULT:	ADOPTED [UNANIMOUS]
MOVER:	Gerald Kaminski, Councilmember
SECONDER:	Diane Benczkowski, Councilmember
AYES:	Holtz, Rogowski, Kaminski, Wozniak, Benczkowski, Meyers



26. RESOLUTION 2014-317

2014 Family Support Service Contract

Sponsored By: Councilmember Wozniak, Councilmember Rogowski

BE IT RESOLVED that subject to approval by the Town Attorney the Supervisor be and hereby is authorized to execute the 2014 Family Support Service Contract in the amount of \$28,886.00, on behalf of the Department of Youth & Recreational Services and the New York State Office for People with Developmental Disabilities.

RESULT:	ADOPTED [UNANIMOUS]
MOVER:	Angela M. Wozniak, Councilmember
SECONDER:	James P. Rogowski, Councilmember
AYES:	Holtz, Rogowski, Kaminski, Wozniak, Benczkowski, Meyers



27. RESOLUTION 2014-318

HOME Program Subrecipient Agreement

Sponsored By: Councilmember Benczkowski, Supervisor Holtz

WHEREAS, the Towns of Cheektowaga, Amherst and Tonawanda have formed a Consortium for the purpose of applying for Entitlement HOME funds from the United States Department of Housing and Urban Development under the HOME Investment Partnership Act, and

WHEREAS, the Town of Amherst has been designated as the lead community on behalf of the Amherst-Cheektowaga-Tonawanda HOME Consortium,

WHEREAS, as lead community, the Town of Amherst, is responsible for the distribution of funds to the subrecipient Consortium communities which manage projects utilizing said HOME funds, and

WHEREAS, the Department of Housing and Urban Development requires the lead community and recipients of HOME funds to execute subrecipient agreements, NOW, THEREFORE, BE IT

RESOLVED, that the Supervisor be and hereby is authorized to execute a Subrecipient Agreement with the Town of Amherst, as lead community for the Amherst-Cheektowaga-Tonawanda HOME Consortium, subject to review and approval by the Town Attorney and the Director of Community Development, for the receipt of HOME Investment Partnership Act funds for the Fiscal Year 2014 program year.

RESULT:	ADOPTED [UNANIMOUS]
MOVER:	Diane Benczkowski, Councilmember
SECONDER:	Mary Holtz, Supervisor
AYES:	Holtz, Rogowski, Kaminski, Wozniak, Benczkowski, Meyers



28. RESOLUTION 2014-319

Approve Submission of FY 2014 Annual Action Plan to HUD

Sponsored By: Councilmember Benczkowski, Supervisor Holtz

WHEREAS, the Town of Cheektowaga is eligible to receive \$943,802 in Community Development Block Grant Funds and \$226,030 in HOME Investment Partnership funds for the 2014 program year from the United States Department of Housing & Urban Development, and

WHEREAS, Public hearings regarding the use of said funds were held on November 18, 2013 and January 21, 2014, and

WHEREAS, the United States Department of Housing & Urban Development added an additional \$107,357 in CDBG funds and \$39,323 in HOME funds to the original draft plan that was reviewed by the public, and

WHEREAS, the increase in CDBG and HOME funds were added to the Single Family Housing Rehabilitation activity, consistent with the treatment of such funding changes described in the *Contingency Provision* contained in the draft Annual Action Plan reviewed by the public, and

WHEREAS, the Town Director of Community Development has submitted recommendations regarding the use of said funds, which includes activities to principally benefit low-income persons pursuant to the goals and objectives of the Housing and Community Development Act, as amended, and its governing rules and regulations, NOW, THEREFORE, BE IT

RESOLVED, that the Town Board hereby adopts and approves the submission of the Town of Cheektowaga Community Development Block Grant Program Annual Action Plan for the 2014 Program Year to the Department of Housing and Urban Development, including the projects contained in the attached CDBG and HOME Project Summaries, and BE IT

FURTHER RESOLVED, that the Supervisor is hereby authorized to sign the required Certifications and any other Community Development Block Grant and HOME Program related documents as may be necessary, including annual grant agreements, with the United States Department of Housing and Urban Development, and BE IT

FURTHER RESOLVED, that the Supervisor is also authorized to sign the required Sub Recipient Agreements with the Villages of Depew and Sloan, as well as Belmont Housing Resources for WNY, Child & Family Services, and Supportive Services, which are the not-for-profit agencies assigned to carry out the services as outlined in the Annual Action Plan.

Town of Cheektowaga
Community Development Block Grant Program Budget
2014 Program Year

<u>Town of Cheektowaga</u>	
Administration	\$ 119,942
Administration - Special Projects (Consultants for required HUD reports)	18,000

Public Information	10,000
Neighborhood Planning.....	15,000
Housing Rehabilitation - Single Family Owner-Occupied Units	220,957
Housing Rehabilitation - Multi-Family Owner-Occupied Units.....	80,900
Sump Pump Grant	10,000
Weatherization	29,400
Rehabilitation Activity Delivery Costs	206,843
Dispositions	3,000
Cleanup of Contaminated Site for Assisted Living Facility	25,000
Cedar Grove Public Services	5,000
Domestic Violence Program.....	18,000
Fair Housing	1,000
Foreclosure Prevention Activities & Counseling Services.....	6,000
Housing Counseling Services	5,000
Public Safety - Police Foot Patrols	33,000
Senior Citizen Services Outreach Assistant	9,000
Summer Day Camp for Children	22,000
Concentrated Code Enforcement.....	5,000
Contingency - Unprogrammed Funds.	3,860
<u>Village of Depew</u>	71,600
\$25,000 - Sidewalk Replacement	
25,000 - Public Safety-Police Foot Patrols	
8,000 - Senior Citizen Van Driver	
13,600 - Senior Services Center Support Staff	
<u>Village of Sloan</u>	<u>25,300</u>
\$10,000 - Demolitions	
10,000 - Playground Equipment for Parks	
5,300 - Drainage and Sewer Improvements	
Total 2014 CDBG Allocation	943,802
Projected Revolving Program Income - Housing Rehabilitation.....	210,000
Projected Revolving Program Income - Economic Development.....	<u>300,000</u>
Total Available Funds for CDBG Activities	<u>\$ 1,453,802</u>

HOME Investment Partnership Program Budget

First-Time Homebuyers Program	\$ 35,000
Consortium Administration Costs	9,000
Town Administration Costs.....	1,670
CHDO Administration - Consortium Allocation	5,000
Housing - Major Rehabilitation Program.....	<u>175,360</u>
Total 2014 HOME Allocation	226,030
Projected Revolving Program Income	50,000
\$1,707 - First-Time Homebuyers Program	
48,293 - Housing - Major Rehabilitation Program	
Prior Year Actual Revolving Program Income	<u>112,022</u>
\$11,202 - Program Administration	
30,000 - First-Time Homebuyers Program	
50,000 - Housing - Major Rehabilitation Program	

20,820 - Housing Rehabilitation

Total Projected Available Funds for HOME Activities \$ 388,052

RESULT:	ADOPTED [UNANIMOUS]
MOVER:	Diane Benczkowski, Councilmember
SECONDER:	Mary Holtz, Supervisor
AYES:	Holtz, Rogowski, Kaminski, Wozniak, Benczkowski, Meyers



29. RESOLUTION 2014-320

Order Replacement of Sidewalks

Sponsored By: Councilmember Kaminski, Supervisor Holtz

WHEREAS, Chapter 210 of the Code of the Town of Cheektowaga (Streets and Sidewalks) sets forth the specifications for the construction of sidewalks in the Town of Cheektowaga, and

WHEREAS, Section 200-a of the Town Law of the State of New York authorizes a town board to adopt a local law to apportion the expense of building, relaying and repairing sidewalks in towns between the town and property owners, and

WHEREAS, this Town Board, by Local Law No. 4 of the Year 1991 and Local Law No. 5 of the Year 2008 (amended by Local Law No. 3 of the Year 2013), adopted provisions to apportion the cost of relaying or repairing sidewalks in the Town of Cheektowaga between the Town and property owners, and

WHEREAS, the Town Superintendent of Highways has supplied this Town Board with the attached list of sidewalks in the Town which are in need of repair or replacement, NOW, THEREFORE, BE IT

ORDERED, that the owners of properties on the attached list be and hereby are directed to repair/replace the sidewalks abutting such properties on or before June 16, 2014, in accordance with the Town's Streets and Sidewalks Law, and BE IT FURTHER

ORDERED, that, should such property owners neglect to or choose to not repair/replace their sidewalks as so notified before June 16, 2014, the Town will cause such sidewalks to be repaired/replaced; will pay \$46.40-51.20 for each 5-foot linear block repaired/replaced; and will assess/charge the property owner the balance over a period of five (5) years on the County/Town tax bill, with interest at the rate of 6.00 % as authorized by State law; or, at the property owner's option, payment may be made in one lump sum before September 2, 2014, and BE IT FURTHER

ORDERED, that the Town Clerk be and hereby is directed to notify the owners of properties identified on the attached list of the adoption of this Order by sending the attached Notice via certified mail to each owner at his/her/their address as it appears on the Town Assessment Roll.

**NOTICE OF ADOPTION OF ORDER
OF THE TOWN BOARD OF THE TOWN OF CHEEKTOWAGA**

TAKE NOTICE THAT, pursuant to a resolution adopted by the Town Board of the Town of Cheektowaga on May 19, 2014,

YOU ARE HEREBY ORDERED to repair the sidewalk in front of your property.

Such work must be completed on or before **June 16, 2014.**

In the event you neglect or choose not to perform this work before the specified date, be advised that the Town of Cheektowaga shall cause such work to be done. The Town will audit and pay \$46.40-\$51.20 for each 5-foot linear block replaced; and will assess the remaining expense thereof (including interest at the rate of 6.00%) against your property in five (5) annual installments; this amount will be added to your town tax bills for the next five (5) years and shall become a lien on your property. In the alternative, you may pay your share of the cost directly to the Town provided you do so on or before September 2, 2013. You will be notified of the amount you owe for sidewalk repairs.

If the Town performs the work, it is estimated that your cost for sidewalk repair will be approximately \$69.60-\$76.80 per 5-foot linear block of sidewalk.

If you choose to perform the work yourself or have a contractor perform such work, be advised that you will be responsible for paying 100% of the cost of the sidewalk work (**the Town will not pay anything towards your cost**).

BY ORDER OF THE TOWN BOARD OF THE TOWN OF CHEEKTOWAGA, ERIE COUNTY, NEW YORK.

DATED: May 19, 2014

ALICE MAGIERSKI
Town Clerk

Attachments:

Sidewalk list 5-19-14-05122014040238 (PDF)

RESULT:	ADOPTED [5 TO 0]
MOVER:	Gerald Kaminski, Councilmember
SECONDER:	Mary Holtz, Supervisor
AYES:	Holtz, Rogowski, Kaminski, Benczkowski, Meyers
ABSTAIN:	Angela M. Wozniak



30. RESOLUTION 2014-321

Unsafe-Unsecured/51 East End Avenue

Sponsored By: Councilmember Benczkowski, Supervisor Holtz

WHEREAS, Town of Cheektowaga Law for the Administration and Enforcement of the Codes of New York State; and the Property Maintenance Code of New York State require that all vacant structures and premises shall be maintained in clean, safe, secure and sanitary conditions so as not to cause a blighting problem or adversely affect the public health or safety and all nuisances abated, AND

WHEREAS, the Town of Cheektowaga has received notification of an unsafe structure and premises located at 51 East End Avenue, Cheektowaga, New York SBL# 90.84-1-18 That is a danger to the safety of others, and records kept by the Assessors Office identify Valerie J. Bates, 215 Burke Drive, Cheektowaga, New York 14215, as the owner AND

WHEREAS, an inspection of such premises was conducted at 51 East End Avenue, by the Housing and Neighborhood Preservation Office, AND

WHEREAS, such inspection found the premises to be deteriorated, vacant, a hazard, and a danger to the safety and well being of others, AND

WHEREAS, the Town of Cheektowaga Housing and Neighborhood Preservation Office properly notified the property owner in accordance with the Town of Cheektowaga Law for the Administration and Enforcement of the Codes of New York State, and the owner failed to take actions to safeguard the premises, AND

WHEREAS, these conditions require the Town of Cheektowaga Housing and Neighborhood Preservation Office to take immediate steps to safeguard the premises to protect the health and safety of others and abate all nuisances, NOW, THEREFORE BE IT

RESOLVED, that pursuant to Section 70-7A.(5) and Section 70-8 of the Town of Cheektowaga Law for the Administration and Enforcement of the Codes of New York State that the vacant structure premises be safeguarded and all nuisances abated; and all costs incurred be assessed against the property hereinbefore described.

RESULT:	ADOPTED [UNANIMOUS]
MOVER:	Diane Benczkowski, Councilmember
SECONDER:	Mary Holtz, Supervisor
AYES:	Holtz, Rogowski, Kaminski, Wozniak, Benczkowski, Meyers



31. RESOLUTION 2014-322

Unsafe-Unsecured/64 Hedwig Avenue

Sponsored By: Councilmember Benczkowski, Supervisor Holtz

WHEREAS, Town of Cheektowaga Law for the Administration and Enforcement of the Codes of New York State; and the Property Maintenance Code of New York State require that all vacant structures and premises shall be maintained in clean, safe, secure and sanitary conditions so as not to cause a blighting problem or adversely affect the public health or safety and all nuisances abated, AND

WHEREAS, the Town of Cheektowaga has received notification of an unsafe structure and premises located at 64 Hedwig Avenue, Cheektowaga, New York SBL# 102.53-2-3 That is a danger to the safety of others, and records kept by the Assessors Office identify Mark Ragin, 3000 W Ann Road, STE #102, N Las Vegas, NV 89031, as the owner AND

WHEREAS, an inspection of such premises was conducted at 64 Hedwig Avenue, by the Housing and Neighborhood Preservation Office, AND

WHEREAS, such inspection found the premises to be deteriorated, vacant, a hazard, and a danger to the safety and well being of others, AND

WHEREAS, the Town of Cheektowaga Housing and Neighborhood Preservation Office properly notified the property owner in accordance with the Town of Cheektowaga Law for the Administration and Enforcement of the Codes of New York State, and the owner failed to take actions to safeguard the premises, AND

WHEREAS, these conditions require the Town of Cheektowaga Housing and Neighborhood Preservation Office to take immediate steps to safeguard the premises to protect the health and safety of others and abate all nuisances, NOW, THEREFORE BE IT

RESOLVED, that pursuant to Section 70-7A.(5) and Section 70-8 of the Town of Cheektowaga Law for the Administration and Enforcement of the Codes of New York State that the vacant structure premises be safeguarded and all nuisances abated; and all costs incurred be assessed against the property hereinbefore described.

RESULT:	ADOPTED [UNANIMOUS]
MOVER:	Diane Benczkowski, Councilmember
SECONDER:	Mary Holtz, Supervisor
AYES:	Holtz, Rogowski, Kaminski, Wozniak, Benczkowski, Meyers



32. RESOLUTION 2014-323

Retention of Outside Counsel for Assessment Litigation Matters

Sponsored By: Councilmember Benczkowski, Supervisor Holtz

WHEREAS, each year, various Real Property Tax Law Article 7 proceedings are commenced against the Town of Cheektowaga and the Town of Cheektowaga Assessor, and

WHEREAS, the Town of Cheektowaga presently retains one firm to represent the Town with respect to these proceedings, and

WHEREAS, due to the potential volume of cases (additional proceedings are expected to be commenced this year), there is a need to retain additional legal counsel to represent the Town's interests in certain of these proceedings in order to protect the integrity of the Town's assessment base, and

WHEREAS, moneys have been budgeted by the Town for this purpose, and

WHEREAS, the Town Attorney's Office has received proposals from outside counsel to handle these matters, NOW, THEREFORE, BE IT

RESOLVED, that Bengart & DeMarco, LLP, Attorneys at Law, be and hereby is retained as outside counsel to represent the Town of Cheektowaga and the Town Assessor in Article 7 proceedings, pursuant to direction from the Town Attorney, as per the proposal submitted by said outside counsel, and BE IT FURTHER

RESOLVED, that payments for said outside counsel shall be appropriated from budget line item number 100-1355-4561.

RESULT:	ADOPTED [UNANIMOUS]
MOVER:	Diane Benczkowski, Councilmember
SECONDER:	Mary Holtz, Supervisor
AYES:	Holtz, Rogowski, Kaminski, Wozniak, Benczkowski, Meyers



33. RESOLUTION 2014-324

Youth & Recreation Transfers

Sponsored By: Councilmember Wozniak, Councilmember Rogowski

BE IT RESOLVED that the individuals listed below be and hereby are transferred, as indicated, in the Department of Youth & Recreational Services, effective immediately:

Recreation Attendant - 7140.1614 - \$9.00 - Regular Part-time

Paige Melin

Transfer from Adapted Recreation Program to Alexander and Dartwood Camps

Recreation Aide - 7310.1801 Alexander Day Camps- \$8.00 - Part-time

Jessica Gaffney

Natalie Stack

Kourtney Killian

Recreation Attendant - 7310.1801 Alexander Day Camps- \$8.00 - Regular Part-time

Brittany Donovan

Jessica Elston

Emily Ferber

Brian Wroblewski

Recreation Attendant - 7310.1801 Alexander Day Camps- \$8.15 - Regular Part-time

Ashley Carney

Caitlyn Ferber

Amanda Fischer

Lily-Boyd Gamel

Danielle Keller

Tyler Nosal

Jenna Soldaczewski

Rebecca Szyjka

Ryan Trapper

Theresa Tripi

Recreation Attendant - 7310.1801 Alexander Day Camps- \$8.30 - Regular Part-time

Eric Fiorello

Recreation Attendant - 7310.1801 Alexander Day Camps - \$8.75 - Regular Part-time

Allison Herman

Sean McCowan

Recreation Instructor - 7310.1801 Alexander Day Camps- \$8.80 - Regular Part-time

Liza Fiorello

Shannon Kelly

Recreation Instructor - 7310.1801 Alexander Day Camps- \$9.05 - Regular Part-time

Ann Marie Heide

Recreation Instructor - 7310.1801 Alexander Day Camps- \$9.30 - Regular Part-time
Kristen Stadelmeyer

Recreation Instructor - 7310.1801 Alexander Day Camps- \$10.25 - Regular Part-time
Maribeth Stadelmeyer

Recreation Specialist - 7310.1801 Alexander Day Camps- \$15.15 - Regular Part-time
Amy McMahon

Recreation Specialist - 7310.1801 Alexander Day Camps- \$15.50 - Regular Part-time
Beatrice Quinn

Recreation Attendant - 7140.1632 Camp Dartwood - \$8.15 - Regular Part-time
Tracey Marlinski
Carolyn Reczek

Recreation Instructor - 7140.1632 Camp Dartwood - \$9.30 - Regular Part-time
Jessica Maleck

Motion by Councilmember Benczkowski; Seconded by Councilmember Rogowski to waive the reading of names for the following three (3) resolutions: 2014-324, 2014-325 and 2014-326. Motion Carried.

RESULT: **ADOPTED [UNANIMOUS]**
MOVER: Angela M. Wozniak, Councilmember
SECONDER: James P. Rogowski, Councilmember
AYES: Holtz, Rogowski, Kaminski, Wozniak, Benczkowski, Meyers



34. RESOLUTION 2014-325

Youth & Recreation Hiring

Sponsored By: Councilmember Wozniak, Councilmember Rogowski

BE IT RESOLVED that the individuals listed below be and hereby are hired, as indicated, in the Department of Youth & Recreational Services, effective immediately:

Recreation Attendant - 7310.1814 - \$8.30 - Regular Part-time

Cinthia Radomski 14227

Recreation Aide - 7140.1614 & 7140.1815 - \$8.00 - Part-time

Jayson Schultz 14211

Recreation Aide - 7310.1801- Alexander Day Camps - \$8.00 - Part-time

Paige Casillo 14227

Trevor Krzemien 14227

Alexe Wodowski 14227

Recreation Attendant - 7310.1801- Alexander Day Camps - \$8.00 - Seasonal

Jennifer Buczek 14227

Alexandria Makowski 14206

Melissa Owczarzak 14043

Maria Serio 14225

Ashley Spencer 14211

Recreation Attendant - 7140.1632 - Dartwood Day Camp - \$8.00 - Seasonal

Jessica Calandra 14215

Recreation Attendant - 7140.1632 - Dartwood Day Camp - \$8.25 - Seasonal

Joseph Malicki 14043

Laborer - "Bathhouse Attendant - Level II"- \$8.15 - Seasonal

Tyler Ditta 14211

Amanda Kraus 14225

Joshua MacTarnaghan 14043

Sara Piwowarski 14043

Laborer - "Bathhouse Attendant - Level III" - \$8.25 - Seasonal

Nolan Calos 14227

Paul Ciaflone 14227

Elizabeth Johnston 14227

Zachery Russillo 14227

Hayley Wnuk 14043

Laborer - "Bathhouse Attendant - Level IV"- \$8.35 - Seasonal

Kelley Astyk 14227

Sara Kapanek 14206

Paul A. Nazzalett 14227

Lifeguard - "Level I" - 7180.1903 - \$9.00 - Regular Part-time

Bryce Bielanin	14215
Justin Brackna	14225
Lennon Cavanaugh-Gordon	14215
Jessie Cecere	14225
Shelby Gennocro	14225
Robert Love	14225
Noah Radlich	14225
Alyssa Reesor	14211
Benjamin Sullivan	14225
Stanley Zolnowski	14225

Lifeguard - "Level I" - 7180.1903 - \$9.00 - Seasonal

Lindsey Fritsch	14215
-----------------	-------

Recreation Instructor "Head Lifeguard 2nd shift Town Park - 7180.1902 - \$10.23 - Seasonal

Melissa Farruggio	14227
-------------------	-------

Recreation Instructor "Head Lifeguard 1st shift Town Park"- 7180.1902 - \$10.43 - Seasonal

Nicholas Coronado	14225
-------------------	-------

Recreation Instructor "Supervisor Dingens Pool"- 7180.1902 - \$11.00 - Regular Part-time

Ashley Bajer	14225
--------------	-------

Recreation Instructor "Supervisor 2nd shift Town Park" - 7180.1902 - \$11.52 - Regular Part-time

Caitlin Rieck	14225
---------------	-------

Recreation Instructor - 7310.1801 Alexander Day Camps- \$8.75 - Seasonal

Meggan Empric	14043
---------------	-------

Cheektowaga Conservation CorpsLaborer - "Level I Participant" - 7310.1816 - \$8.00 - Seasonal

Matthew Loos	14225
Rob Tighe	14225

Laborer - "Level I Participant" - 7310.1816 - \$8.00 - Seasonal - Alternate

Joseph Creek	14225
Tyler Elis	14225
Steven Malicki	14206

Recreation Attendant - 7140.1640 - \$8.15 - Regular Part-time - Retro to 4/28/14

Anthony Overfield	14227
-------------------	-------

Recreation Aide - 7140.1636 - \$8.00 - Part-time - Retro to 4/25/14

Eric Wilson	14043
-------------	-------

BE IT FURTHER RESOLVED, the following employee information be amended as follows:

Recreation Attendant - 7140.1636 - \$8.25 - Regular Part-time - Retro to 4/25/14

Alexa Scharf	
--------------	--

Recreation Attendant - 7140.1614 & 7140.1636 - \$8.00 - Regular Part-time - Retro to 4/25/14

Cody Jeziorski 14227

Recreation Attendant - 7140.1636 - \$8.00 - Regular Part-time - Retro to 4/25/14
Marshall Prestia 14211

Recreation Attendant - 7140.1636 - \$8.35 - Regular Part-time - Retro to 4/23/14
Andrew Deeds 14211

Recreation Attendant - 7140.1636 - \$8.40 - Regular Part-time - Retro to 4/24/14
Adam Barrett 14225

RESULT:	ADOPTED [UNANIMOUS]
MOVER:	Angela M. Wozniak, Councilmember
SECONDER:	James P. Rogowski, Councilmember
AYES:	Holtz, Rogowski, Kaminski, Wozniak, Benczkowski, Meyers



35. RESOLUTION 2014-326

Hiring/Termination of Part Time/Seasonal Employees

Sponsored By: Councilmember Kaminski, Supervisor Holtz

BE IT RESOLVED, that the following individuals be and hereby are hired as **SEASONAL EMPLOYEES**, not to exceed five (5) months in a calendar year, in the various departments listed and in compliance with Civil Service Laws and Regulations as well as the provisions of the Town's collective bargaining agreement between the Town of Cheektowaga and the Town of Cheektowaga Employees Association:

SANITATION DEPARTMENT Laborer \$9.25/hour effective 5/5/14
Darryl J. Dunkowski, Cheektowaga, New York

SANITATION DEPARTMENT Laborer \$9.25/hour effective 5/12/14
Michael A. Aikin, Cheektowaga, New York
Anthony F. Chiarmonte, Depew, New York
Joshua A. Parra, Cheektowaga, New York

FACILITIES DEPARTMENT Laborer \$8.25/hour effective 5/6/14
Brandon P. Barczak, Cheektowaga, New York
Brandon M. Kindzierski, Cheektowaga, New York

BE IT RESOLVED, that the following individuals be and hereby are hired as **PART-TIME EMPLOYEES** in the departments listed, not to exceed nineteen (19) hours on a weekly basis, in compliance with Civil Service Laws and Regulations as well as the provisions of the Town's collective bargaining agreement between the Town of Cheektowaga and the Town of Cheektowaga Employees Association:

JUSTICE COURT Clerk \$9.00/hour effective 5/7/14
Ashley M. Young, Cheektowaga, New York
Michael E. Cieslinski, Cheektowaga, New York
June M. Bosworth, Cheektowaga, New York

COMMUNITY DEVELOPMENT Clerk \$10.50/hour effective 5/19/14
Andrew J. Kistner, Cheektowaga, New York

BE IT RESOLVED, that the following seasonal and/or part-time employees be and hereby are terminated as listed:

SANITATION DEPARTMENT
Dominique T. Pearsall effective 4/30/14

FACILITIES DEPARTMENT
Mark R. Aguglia effective 4/23/14

RESULT: **ADOPTED [UNANIMOUS]**
MOVER: Gerald Kaminski, Councilmember
SECONDER: Mary Holtz, Supervisor
AYES: Holtz, Rogowski, Kaminski, Wozniak, Benczkowski, Meyers



36. RESOLUTION 2014-327

Creation of Assistant Field Assessor and Part-Time Coordinator of Employee Relations

Sponsored By: Councilmember Kaminski, Supervisor Holtz

BE IT RESOLVED, that this Town Board hereby create one (1) Assistant Field Assessor position and one (1) Coordinator of Employee Relations (Part-Time/Temporary/PJC) position pursuant to Civil Service Laws and Rules effective May 20, 2014.

RESULT:	ADOPTED [UNANIMOUS]
MOVER:	Gerald Kaminski, Councilmember
SECONDER:	Mary Holtz, Supervisor
AYES:	Holtz, Rogowski, Kaminski, Wozniak, Benczkowski, Meyers



37. RESOLUTION 2014-328

Return Temporary Senior Clerk Typist to Court Clerk (Andrea L. Spence)

Sponsored By: Councilmember Benczkowski, Councilmember Kaminski

WHEREAS, a temporary Senior Clerk Typist position was available in the Justice Court;
AND

WHEREAS, Court Clerk Andrea Spence was appointed to this temporary Senior Clerk Typist vacancy on April 21, 2014; AND

WHEREAS, the temporary Senior Clerk Typist position is no longer available; NOW,
THEREFORE, BE IT

RESOLVED, that Andrea Spence be and hereby is to return to her permanent title of Court Clerk in accordance with the terms and conditions of the Town's collective bargaining agreement with the Town of Cheektowaga Employees Association effective May 5, 2012.

RESULT:	ADOPTED [UNANIMOUS]
MOVER:	Diane Benczkowski, Councilmember
SECONDER:	Gerald Kaminski, Councilmember
AYES:	Holtz, Rogowski, Kaminski, Wozniak, Benczkowski, Meyers



38. RESOLUTION 2014-329

Appointment to Cheektowaga Economic Development Corporation Directors

Sponsored By: Councilmember Benczkowski, Supervisor Holtz

WHEREAS, the Town Board of the Town of Cheektowaga previously created the Cheektowaga Economic Development Corporation for the purpose of assisting and encouraging economic development within the Town, and

WHEREAS, By Resolution dated February 7, 1983 this Town Board approved the By-Laws of the Cheektowaga Economic Development Corporation which provide that the Directors of the Cheektowaga Economic Development Corporation be appointed by resolution of the Cheektowaga Town Board, and

WHEREAS, the Cheektowaga Economic Development Corporation Board of Directors has unanimously recommended the appointment of the individuals listed below to the Board of Directors of the Cheektowaga Economic Development Corporation for a term of three years, NOW, THEREFORE, BE IT

RESOLVED, that the following individuals are hereby appointed to the Board of Directors of the Cheektowaga Economic Development Corporation, effective immediately for a term of three years, said term expiring at the time of reappointment to said Board of Directors positions in 2017, but no later than June 30, 2017:

James Antkowiak
 Stephen L. Bojda
 Dennis Serugendo
 Richard Velez

RESULT:	ADOPTED [UNANIMOUS]
MOVER:	Diane Benczkowski, Councilmember
SECONDER:	Mary Holtz, Supervisor
AYES:	Holtz, Rogowski, Kaminski, Wozniak, Benczkowski, Meyers



39. RESOLUTION 2014-330

Travel Authorization Police Department/Police Officers Michael Scapillato, Timothy Turnbull, Emil DeVincentis, and Jeffrey Fial

Sponsored By: Councilmember Benczkowski, Councilmember Kaminski

WHEREAS, the International Conference Event Series, "Better Together Anti-Bullying and School and Community Safety Conference" is being held July 8 through July 10, 2014 in Grapevine, Texas; AND

WHEREAS, Police Officers Michael Scapillato, Timothy Turnbull, Emil DeVincentis, and Jeffrey Fial have been recommended to attend said conference; AND

WHEREAS, Police Chief David Zack has submitted a request for travel authorization along with the proper paperwork in a timely manner; AND

WHEREAS, the total cost to the Town shall not exceed \$6,084; AND

WHEREAS, these expenses have been budgeted by the Department; NOW,
THEREFORE, BE IT

RESOLVED, that Police Officers Michael Scapillato, Timothy Turnbull, Emil DeVincentis, and Jeffrey Fial be and hereby are authorized to attend the International Conference Event Series, "Better Together Anti-Bullying and School and Community Safety Conference" being held July 8 through July 10, 2014 in Grapevine, Texas.

RESULT:	ADOPTED [UNANIMOUS]
MOVER:	Diane Benczkowski, Councilmember
SECONDER:	Gerald Kaminski, Councilmember
AYES:	Holtz, Rogowski, Kaminski, Wozniak, Benczkowski, Meyers

V. Suspension of Rules

Motion by Councilmember Rogowski; Seconded by Councilmember Meyers to Waive the Rules to Include the Following Two (2) Resolutions: 2014-331 and 2014-332. Motion Carried.



1. RESOLUTION 2014-331

Authorize Auction of Surplus Vehicles and Equipment

Sponsored By: Councilmember Kaminski, Supervisor Holtz

WHEREAS, the Town wishes to dispose of surplus vehicles and equipment no longer functional or needed for Town use; and

WHEREAS, sale of surplus property by the Town is authorized by Section 64 of the Town Law of the State of New York; and

WHEREAS, Auctions International, Inc. will sell such surplus vehicles and equipment at an online auction; NOW THEREFORE, BE IT

RESOLVED, that the Town hereby retains Auctions International, Inc., 11167 Big Tree Road (20A), East Aurora, New York, 14052, to conduct a sale of the surplus Town vehicles and equipment identified on the attached list entitled "Vehicles to be Auctioned 2014" at an online auction to be held on its website; and BE IT FURTHER

RESOLVED, that the Supervisor of the Town of Cheektowaga be and hereby is authorized to execute an agreement with Auctions International, Inc., subject to approval by the Town Attorney, and any and all documents that may be required to effectuate the sale and/or transfer of said surplus vehicles and equipment.

Attachments:

Vehicles to be Auctioned 2014 (PDF)

RESULT:	ADOPTED [UNANIMOUS]
MOVER:	Gerald Kaminski, Councilmember
SECONDER:	Mary Holtz, Supervisor
AYES:	Holtz, Rogowski, Kaminski, Wozniak, Benczkowski, Meyers



2. RESOLUTION 2014-332

Award 2014 Contract Grass Cutting for Mt. Hope Cemetery

Sponsored By: Supervisor Holtz, Councilmember Benczkowski

WHEREAS, the Town of Cheektowaga Office of Neighborhood Preservation has been requested to procure grass cutting and debris removal services for Mt. Hope Cemetery, 484 Pine Ridge Heritage, Town of Cheektowaga; and

WHEREAS, the Town of Cheektowaga Office of Neighborhood Preservation has been requested to procure grass cutting and debris removal services for Mt. Hope Cemetery, 484 Pine Ridge Heritage, Town of Cheektowaga; and

WHEREAS, in accordance with the Procurement Policy of the Town of Cheektowaga, the Office of Neighborhood Preservation issued a verbal/fax request for Bidders for Furnishing Equipment and Operators for the Grass Cutting and Debris Removal Services for Mt. Hope Cemetery, 484 Pine Ridge Heritage, Town of Cheektowaga for the Year 2014; and

WHEREAS, responses to said request were referred to the Director of Community Development and Town Attorney for analysis, tabulation and report; and

WHEREAS, based on the proposals submitted, the Director of Community Development has recommended that this Town Board award the contract for Furnishing Equipment and Operators for the Grass Cutting and Debris Removal Services for Mt. Hope Cemetery, 484 Pine Ridge Heritage, Town of Cheektowaga for the Year 2014 to Vincent J. Mancuso, Jr., d/b/a Mancuso Landscaping, for its submission of a proposal to perform said services; NOW, THEREFORE, BE IT

RESOLVED, that the contract for Furnishing Equipment and Operators for the Grass Cutting and Debris Removal Services for Mt. Hope Cemetery, 484 Pine Ridge Heritage, Town of Cheektowaga for the Year 2014 be awarded to Vincent J. Mancuso, Jr., d/b/a Mancuso Landscaping, 7768 Lewis Road, Holland, New York, 14080, for the prices listed in its proposal, said amount being the lowest responsible bid meeting the requirements of the specifications for said services; and BE IT FURTHER

RESOLVED, that the Supervisor be and hereby is directed and authorized to execute a contract with Vincent J. Mancuso, Jr., d/b/a Mancuso Landscaping for the aforesaid services, subject to approval by the Town Attorney.

RESULT:	ADOPTED [UNANIMOUS]
MOVER:	Mary Holtz, Supervisor
SECONDER:	Diane Benczkowski, Councilmember
AYES:	Holtz, Rogowski, Kaminski, Wozniak, Benczkowski, Meyers

VI. Communications

A. Departmental Communications

1. Supervisor's Statement of Funds - April 2014

B. General Communications

1. Notice of Claim: Stephanie McAuley vs. Town of Cheektowaga
2. Notice of Claim: Dan McPhee vs. Town of Cheektowaga

VII. Comments

A. Supervisor's Comments

B. Councilmember's Comments

C. Public Comments

VIII. Adjournment

Motion by Councilmember Rogowski; Seconded by Councilmember Benczkowski to adjourn the meeting at 8:35 PM

Alice Magierski, Town Clerk

**LOCAL LAW NO. 2 OF THE YEAR 2014
A LOCAL LAW TO AMEND THE TAXICABS LAW**

Section 1. REPEALER.

The existing Chapter 223 of the Code of the Town of Cheektowaga (originally adopted October 21, 1985) is hereby repealed.

Section 2. LEGISLATIVE FINDINGS:

It is hereby declared that the taxicab and the livery business is a vital part of the transportation facilities of the Town of Cheektowaga, and that its regulation is necessary to preserve peace, good order and safety for the inhabitants of the town.

Section 3. DEFINITIONS:

As used in this chapter, the following terms shall have the meanings indicated:

Driver: Any person driving a taxicab or livery upon the public highways for hire.

Motor Vehicle: Every vehicle operated or driven upon a public highway which is propelled by any power other than muscular power, except electrically-driven mobility assistance devices operated or driven by a person with a disability, vehicles which run only upon rails or tracks, snowmobiles as defined in article forty-seven of the New York Vehicle and Traffic Law and all-terrain vehicles as defined in article forty-eight-B of the New York Vehicle and Traffic Law.

Livery: Any motor vehicle, other than a taxicab or a bus, used in the business of transporting passengers for compensation that does not utilize any type of a taximeter.

Owner: A person owning or controlling one or more taxicabs and/or livery vehicles and driving or causing any such vehicle to be driven upon the public highways for hire.

Person: Includes an individual, a partnership, any unincorporated association, a corporation and any other legal entity.

Taxicab: Any motor vehicle engaged in the business of carrying passengers for hire, having a seating capacity of less than eight persons and not operated on a fixed route.

Taximeter: A mechanical instrument or device by which the charge for hire of a taxicab may be mechanically calculated either for the distance traveled or waiting time, or both, and upon which such charge is indicated by means of figures.

Town: The Town of Cheektowaga, excluding the Buffalo Niagara International Airport, the Village of Sloan and those portions of the Village of Depew within the Town of Cheektowaga.

Section 4. PERMIT REQUIREMENT:

- A. It shall be unlawful for any owner, driver or employee of any taxicab and/or livery to engage in the business of transporting persons for hire in a taxicab or livery from, to, or within the Town without having first obtained and having then in force an owner's permit, as hereinafter provided.
- B. Every owner's permit issued hereunder shall be issued for one (1) year from the date of approval of the application.

Section 5. APPLICATION PROCEDURE FOR TAXICAB OWNERS:

- A. Every person who desires to operate a taxicab or taxicabs and/or livery owned or controlled by that person, upon the public highways within the Town, shall file with the Town Clerk a written application, verified under oath, stating:
1. The name and address of the owner of the taxicab or taxicabs and/or livery, specifying, in the case of any partnership, unincorporated association or other legal entity, the name and address of each member thereof, and, in the case of any corporation, the name and address of each officer, director and stockholder thereof.
 2. The number of vehicles to be operated, a description of each such vehicle, including the make, model, color, passenger capacity, year of manufacture and motor number thereof, and the size of the tires, the make, type and number or other descriptive designation of the taximeter, state registration number and proof of inspection.
 3. The location of any and all depots and terminals proposed to be used by the owner.
- B. If the Town Clerk shall find that all the required forms and documents have been completed and submitted and that the owner is qualified, then the Town Clerk, upon receipt of proof of insurance against public liability for each taxicab and/or livery showing the amounts of coverage, which amounts shall be at least the minimum amount required under New York State law for personal injuries to each person per accident, for total personal injuries for each accident and for property damage and which insurance shall be maintained in full force during the period covered by the permit, and upon receiving payment of the proper fee, shall issue a permit stating the name and address of the owner, the date of the issuance thereof, the number of vehicles the owner is authorized to operate, and the number of the license plate assigned to each vehicle.
- C. Any permit issued here may be renewed annually for additional periods of one year each from the expiration date upon the filing of an application containing all the information required herein.
- D. Every owner issued a permit pursuant to this Chapter who shall desire to add to the number of taxicabs and/or liveries then being operated shall file with the Town Clerk a new written application, under oath, providing all the information required as described in paragraph A hereinabove.

E. If the Town Clerk shall find that the addition of such taxicab(s) and/or livery meets all requirements, then he/she shall issue an owner's permit stating the name and address of the applicant, the numbers of the license plate assigned to such vehicles and the date of issuance thereof.

F. The owner's permit issued hereunder shall not be transferable or assignable to any other person.

Section 6. FEES FOR OWNER'S PERMIT:

A. The fee for a taxicab owner's permit and a livery owner's permit shall be the sum of \$25.00 per year for each vehicle and/or \$200.00 for a fleet of up to ten (10) vehicles. For replacing a lost permit, the fee shall be \$10.00. In case of the sale or disuse for taxicab and/or livery purposes of any permitted taxicab and/or livery, the holder of the taxicab and/or livery permit may have the same transferred to another vehicle owned by him, with the approval of the Town Clerk and the payment of a transfer fee of \$15.00.

Section 7. APPLICATION PROCEDURE FOR TAXICAB AND LIVERY DRIVERS:

A. Each owner shall provide a list of all vehicle operators who will be operating the taxicab(s) and/or livery(ies), as the case may be, that have a permit issued pursuant to this Chapter along with a copy of the drivers' licenses for all such operators and two passport size photos of each driver.

B. Each driver will be required to complete an application that will be provided by the Town Clerk's Office and shall also have a background check completed by the Town Police Department.

C. Upon approval by the Town Clerk of the application and approval by the Town Police Department of the background check, each driver shall be issued a Taxicab/Livery Driver Permit Identification Card.

D. Each driver shall carry his/her Taxicab/Livery Driver Permit Identification Card with him/her at all times while operating a taxicab/livery within the Town.

E. Each owner shall take all necessary steps to update that list of drivers whenever drivers are added or deleted. Under no circumstances shall an owner allow anyone to operate any of owner's taxicabs and/or liveries for the purpose of transporting persons for hire from, to, or within the Town who has not completed the application process set forth herein and who has not been issued a Taxicab/Livery Driver Permit Identification Card.

F. Every driver's Permit Identification card issued hereunder shall be issued for one (1) year from the date of approval of the application.

Section 8. FEES FOR DRIVER'S PERMIT:

A. The fee for a taxicab/livery driver's Permit Identification Card shall be the sum of \$25.00 per year for each driver. For replacing a lost driver's permit, the fee shall be \$10.00. Driver's permits are non-transferable.

B. In any case where an owner has paid for and been issued a taxicab/livery owner's permit to operate a taxicab or taxicabs and/or livery owned by that person and that person is also seeking to obtain a taxicab/livery driver's Permit Identification Card to operate that vehicle, the fee for the taxicab/livery driver's Permit Identification Card for that owner shall be waived.

Section 9. APPLICATION TO TOWN BOARD FOR REVIEW OF ACTION DENYING A PERMIT

A. Any applicant who shall have been denied an owner's and/or operator's permit under this chapter may apply to the Town Board for a review of the action of the Town Clerk, as hereinafter provided:

1. Such application to the Town Board shall be in writing, signed and acknowledged by the applicant, and shall state the ground or grounds on which the applicant claims that the determination of the Town Clerk was erroneous.
2. Such application shall be filed with the Town Clerk by the applicant within 20 days after notice of denial of his/her license by the Town Clerk has been mailed to him or delivered to him in person.
3. Upon the filing of such application, the Town Board shall hold a hearing thereon pursuant to the provisions set forth in subparagraph B herein below.
4. At such hearing, the Town Board shall consider the applicant's application upon the record before the Town Clerk in connection with the Town Clerks consideration thereof, and, in its discretion, may receive new or additional evidence in support thereof or in opposition thereto.
5. The Town Board, after such hearing, may affirm the action of the Town Clerk or direct the Town Clerk to issue a proper permit pursuant to this chapter.

B. Whenever it shall be provided herein that a hearing shall or may be held by the Town Board with respect to any matter:

1. Such hearing shall be held on a date and at a place and hour designated by the Town Board.
2. The Town Clerk shall give notice thereof, stating the name and address of the applicant or license holder concerned, the subject matter of the hearing, and the date, place and hour thereof designated therefor, by mailing a copy thereof to the applicant or license holder concerned, at the address shown upon the most recent application of such applicant or licensee, at least 10 days before such hearing.
3. The applicant or license holder involved shall be entitled to be represented by legal counsel and to present such competent and material testimony or other evidence in his/her own behalf as may be relevant to the subject matter of the hearing.
4. All witnesses shall be sworn and examined under oath.

Section 10. OPERATION OF TAXIMETERS:

- A. No motor vehicle utilizing a taximeter shall be used for hire unless that taximeter is in full compliance with all applicable local and state statutes, rules and regulations and has an official seal from the appropriate authorizing authority.
- B. No taximeter shall be operated from either rear wheel of such vehicle, and the figures thereon shall be illuminated and visible to the passenger from the rear seat of the vehicle.
- C. No taximeter shall be operated unless said taximeter and speedometer are in proper working condition.
- D. It shall be unlawful to change the size of the front wheels or tires of a taxicab or livery or the gears operating the taximeters, or to change said instrument from one vehicle to another.
- E. All taximeters shall have an intact cover and gears and no person shall or allow the use of a taximeter on which the seal has been broken.

Section 11. GENERAL RULES OF OPERATION:

- A. No taxicab or livery driver shall leave his/her vehicle without shutting off the radio.
- B. No driver shall blow his/her horn, shout or use a loud tone to solicit a fare.
- C. No driver shall idle the motor of his/her vehicle excessively at any time.
- D. It shall be the duty of each taxicab driver to keep a record of the point of origin and point of destination of all trips made and the charge made therefor, and to file the same with the owner of the taxicab and such records shall be preserved for at least six months and shall be made available for inspection by the Police Department during said period.
- E. It shall be the duty of each livery vehicle driver to have a printed form that provides the date, time and location of each pick-up, the name, address and telephone number of the person(s) who ordered the service, the destination each person is being transported to and the price being charged for the transportation service.
- F. The numbered permit assigned to each vehicle by the Town Clerk must be affixed to the vehicle in a conspicuous place at the rear of the vehicle and cannot be transferred to another vehicle.
- G. Each taxicab operated hereunder shall bear on the outside of at least one door on each side of the vehicle the word "TAXI."
- H. No taxicab or livery driver shall solicit passengers except when sitting in the driver's compartment of such taxicab or livery, as the case may be, or while standing immediately adjacent thereto, nor in a loud or annoying tone or voice nor by sign nor in any manner annoy, obstruct the movement of or follow any person for the purpose of soliciting patronage.
- I. No taxicab or livery driver shall stop to pick up any additional passengers while proceeding to the destination of any passenger then occupying the taxicab or livery, as the case may be, without the consent of all such passengers.

J. No taxicab or livery driver shall permit more persons to be carried in his/her taxicab or livery, as the case may be, than the number for which he/she has seating facilities.

K. Every taxicab and livery driver, as soon as practicable after his/her taxicab or livery, as the case may be, is emptied of passengers, shall carefully search his/her vehicle for any property left there by any passenger, and if he shall find any such property, he/she shall as soon as reasonably practical deliver it to the Police Department in Cheektowaga.

L. The interior and exterior of all vehicles operated pursuant to the chapter shall be clean and sanitary at all times.

Section 12. VIOLATIONS:

A. Violation of any of the provisions of this chapter shall be punishable by a fine of not to exceed \$500.00 for each offense. Each day in which violations of these provisions occur shall constitute a separate offense. Should an owner or a driver be convicted of three violations of this chapter within any eighteen (18) month period, then the permit granted to such owner or operator pursuant to this chapter may be suspended or revoked.

B. It shall be a violation for any taxicab and/or livery owner to have a taxicab or livery operating within the Town while having a revoked or suspended permit and for any taxicab or livery driver to operate a taxicab and/or livery within the Town while having a revoked or suspended permit. Each time a taxicab or livery owner or driver operates a taxicab and/or a livery within the Town while having a revoked or suspended permit shall constitute a separate offense. Such offenses shall be punishable by a fine not to exceed \$250.00 for the first offense, \$500.00 for the second offense and \$1,000.00 for any additional offenses.

Section 13. EXCLUSIONS

The provisions of this chapter pertaining to obtaining an owner's permit and/or a driver's permit shall not apply to any taxicab or livery that is registered outside of the State of New York.

	A	B	C	D	E	F	H	I	L	O
1	print key	loc st n br	loc st name	loc m ail st suff	Blocks (walk)	App- roach	Owner Name	2-Owner Name	Address	City/State/Zip
2	91.10-11-17	106	Beale	Ave.		1	Michael A. & Kelly A. Board		106 Beale Ave.	Chktg., NY 14225-2020
3	91.10-12-7	109	Beale	Ave.	2		James J. Cwiklinski &	Tina M. Campagna	109 Beale Ave.	Chktg., NY 14225-2006
4	91.10-11-16	110	Beale	Ave.	3		Karen M. Walkowiak		110 Beale Ave.	Chktg., NY 14225
5	91.10-12-8	115	Beale	Ave.	4		Gary & Karen Reed		115 Beale Ave.	Chktg., NY 14225-2006
6	91.10-12-9	119	Beale	Ave.	1		Debra L. Wanat		119 Beale Ave.	Chktg., NY 14225
7	91.10-11-14	120	Beale	Ave.	2		Jacqueline M. Lovern		120 Beale Ave.	Chktg., NY 14225
8	91.10-12-11	129	Beale	Ave.	1		Michael D. Neri	Kathleen M. Neri	129 Beale Ave.	Chktg., NY 14225-2006
9	91.10-11-12	130	Beale	Ave.	3		Heather A. Cassatt-Sayers		130 Beale Ave.	Chktg., NY 14225-2020
10	91.09-3-27	14	Beale	Ave.	2		William A. McIlhagga	Scott M. McIlhagga	14 Beale Ave.	Chktg., NY 14225-2009
11	91.10-8-56	146	Beale	Ave.	1		Vicki C. Carr		146 Beale Ave.	Chktg., NY 14225-2108
12	91.10-7-2	149	Beale	Ave.	4		Joseph Vicari	Jennifer Vicari	149 Beale Ave.	Chktg., NY 14225-2107
13	91.10-8-54	156	Beale	Ave.		2	Rebekah N. Davis		156 Beale Ave.	Chktg., NY 14225-2108
14	91.10-8-53	160	Beale	Ave.	4		Brian T. Lindell		160 Beale Ave.	Chktg., NY 14225-2108
15	91.10-8-52	166	Beale	Ave.	4		Daniel A. Vohwinkel	Virginia B. Vohwinkel	166 Beale Ave.	Chktg., NY 14225-2108
16	91.10-8-51	170	Beale	Ave.	1		Ricky F. Puszert	Mary A. Puszert	170 Beale Ave.	Chktg., NY 14225-2108
17	91.10-8-50	176	Beale	Ave.	3		Kathleen M. Kielar		176 Beale Ave.	Chktg., NY 14225-2108
18	91.10-7-8	179	Beale	Ave.	1		Ellen A. Meier	Linda S. Meier	179 Beale Ave.	Chktg., NY 14225-2107
19	91.10-7-9	185	Beale	Ave.		2	Maria Frayne-Wesolowski		185 Beale Ave.	Chktg., NY 14225-2107
20	91.10-8-48	186	Beale	Ave.	3		Timothy J. & Peggy Lyn Allein		186 Beale Ave.	Chktg., NY 14225-2108
21	91.10-7-10	189	Beale	Ave.	1		Eric D. Kannisto	Phoebe A. Kannisto	189 Beale Ave.	Chktg., NY 14225-2107
22	91.09-4-4	19	Beale	Ave.	3		David J. Coombe & W		19 Beale Ave.	Chktg., NY 14225-2008
23	91.10-7-11	195	Beale	Ave.	2		Lester A. Morris	Carol E. Morris	195 Beale Ave.	Chktg., NY 14225-2107
24	91.10-8-46	196	Beale	Ave.	3		Craig R. Witt	Ann Marie Mercurio	196 Beale Ave.	Chktg., NY 14225-2108
25	91.09-3-26	20	Beale	Ave.	3		Craig W. Lawrence		20 Beale Ave.	Chktg., NY 14225
26	91.10-8-45	200	Beale	Ave.	4		Mark E. Ludwig		2159 Two Rod Rd.	East Aurora, NY 14052-9615
27	91.10-7-13	205	Beale	Ave.	3	1	Sharon Stabler		205 Beale Ave.	Chktg., NY 14225-2119
28	91.10-8-44	206	Beale	Ave.	3		Michael A. & Rachel C. Karpinski		206 Beale Ave.	Chktg., NY 14225-2120
29	91.10-7-14	209	Beale	Ave.	1		Rita T. Jerackas		209 Beale Ave.	Chktg., NY 14225-2119
30	91.10-8-43	210	Beale	Ave.		2	Dawn M. Wingerter		210 Beale Ave.	Chktg., NY 14225-2120
31	91.10-7-15	215	Beale	Ave.	2		David F. Borucki	Linda W. Borucki	215 Beale Ave.	Chktg., NY 14225-2119
32	91.10-8-42	216	Beale	Ave.	1	2	Wayne R. Weiser & W		216 Beale Ave.	Chktg., NY 14225-2120
33	91.10-8-40	226	Beale	Ave.	5		Pamela Pace		226 Beale Ave.	Chktg., NY 14225-2120
34	91.10-7-18	229	Beale	Ave.		2	Riva Fillmore		762 Beach Rd.	Chktg., NY 14225
35	91.10-8-39	230	Beale	Ave.	1		Timothy M. Poliniak		230 Beale Ave.	Chktg., NY 14225-2120
36	91.10-7-19	235	Beale	Ave.	1		Eleanor A. Kankiewicz		235 Beale Ave.	Chktg., NY 14225-2119
37	91.10-8-38	236	Beale	Ave.	1		Richard A. Albright		236 Beale Ave.	Chktg., NY 14225-2120
38	91.10-7-20	239	Beale	Ave.	1		Dolores T. Stein		239 Beale Ave.	Chktg., NY 14225-2119
39	91.10-8-37	240	Beale	Ave.	1		Matthew Johnson		240 Beale Ave.	Chktg., NY 14225
40	91.10-8-35	250	Beale	Ave.	3	1	Jason T. Gress		250 Beale Ave.	Chktg., NY 14225-2120

Attachment: Sidewalk list 5-19-14-05122014040238 (RES-2014-320 : Order Replacement of Sidewalks)

	A	B	C	D	E	F	H	I	L	O
1	print key	loc st n br	loc st name	loc m ail st suff	Blocks (walk)	App- roach	Owner Name	2-Owner Name	Address	City/State/Zip
41	91.10-7-23	255	Beale	Ave.	2	2	Charles J. Rausa &	Peggy J. Rausa	255 Beale Ave.	Chktg., NY 14225-2119
42	91.10-8-34	256	Beale	Ave.	1	3	Genevieve L. Kulpa	Edward Kulpa	256 Beale Ave.	Chktg., NY 14225-2120
43	91.10-7-24	259	Beale	Ave.	5	2	Michael G. Glauber		259 Beale Ave.	Chktg., NY 14225
44	91.10-8-33	260	Beale	Ave.	1		Sharon E. Morlock		260 Beale Ave.	Chktg., NY 14225-2120
45	91.10-8-30	276	Beale	Ave.	3		James A. Cardona	Luz Cardona	276 Beale Ave.	Chktg., NY 14225-2120
46	91.10-8-29	280	Beale	Ave.	5		Theodore Lockett	Sarah A. Wren	280 Beale Ave.	Chktg., NY 14225-2120
47	91.09-3-24	30	Beale	Ave.	2		David Craiglow		30 Beale Ave.	Chktg., NY 14225-2009
48	91.09-4-8	39	Beale	Ave.	2		Travis J. D. Flores		39 Beale Ave.	Chktg., NY 14225
49	91.09-3-21	46	Beale	Ave.	1	1	Paul & Noelle Majerowski		46 Beale Ave.	Chktg., NY 14225-2009
50	91.09-4-10	49	Beale	Ave.	2		Robert B. Hyland Jr.		49 Beale Ave.	Chktg., NY 14225-2008
51	91.09-3-20	50	Beale	Ave.	6	2	Joseph S. Nucci		50 Beale Ave.	Chktg., NY 14225
52	91.09-4-11	55	Beale	Ave.	1		Kathy A. Foster		126 Atlantic Ave.	Buffalo, NY 14212-218
53	91.09-3-17	66	Beale	Ave.	3		Edith M. Snyder		66 Beale Ave.	Chktg., NY 14225-2009
54	91.09-4-14	69	Beale	Ave.	2		Glenn P. Farrell	Jody L. Farrell	69 Beale Ave.	Chktg., NY 14225-2008
55	91.09-3-15	76	Beale	Ave.	3		Natalie M. Rauch	Linda M. Williams	76 Beale Ave.	Chktg., NY 14225-2009
56	91.10-12-1	79	Beale	Ave.	2		Jesse E. Adams III		79 Beale Ave.	Chktg., NY 14225
57	91.09-3-28	8	Beale	Ave.	1		Louise Cerrone		8 Beale Ave.	Chktg., NY 14225-2009
58	91.10-11-22	80	Beale	Ave.	1		Brent Krebs		80 Beale Ave.	Chktg., NY 14225-2009
59	91.10-12-2	85	Beale	Ave.	4		Kenneth W. Boeheim Jr.		85 Beale Ave.	Chktg., NY 14225-2008
60	91.10-12-3	89	Beale	Ave.	4		Camille M. Pirrone-Hess		89 Beale Ave.	Chktg., NY 14225-2008
61	91.10-12-5	99	Beale	Ave.	1		Craig T. Howard		99 Beale Ave.	Chktg., NY 14225
62	80.18-13-11	114	Birkdale	Rd.	6		Norman Fears		114 Birkdale Rd.	Chktg., NY 14225
63	80.18-13-10	118	Birkdale	Rd.	17		Scott W. Lawniczak	Nicole E. Cox	118 Birkdale Rd.	Chktg., NY 14225-1604
64	91.06-6-19	12	Birkdale	Rd.	2		William F. Palmer Jr.	Susan M. Palmer	12 Birkdale Rd.	Chktg., NY 14225
65	91.06-7-23	13	Birkdale	Rd.	2	2	Sharon A. Schaf		13 Birkdale Rd.	Chktg., NY 14225-1615
66	91.06-7-24	17	Birkdale	Rd.	4		Carol A. Stachera		17 Birkdale Rd.	Chktg., NY 14225-1615
67	91.06-7-25	21	Birkdale	Rd.	4		Maria Aquilina		21 Birkdale Rd.	Chktg., NY 14225-1615
68	91.06-7-27	29	Birkdale	Rd.	2		David K. Rey	Denise R. Rey	29 Birkdale Rd.	Chktg., NY 14225-1615
69	91.06-6-14	32	Birkdale	Rd.	1		Nicholas D. Zakowicz		32 Birkdale Rd.	Chktg., NY 14225-1616
70	91.06-7-28	33	Birkdale	Rd.	1		Donald E. Peters		33 Birkdale Rd.	Chktg., NY 14225
71	91.06-6-13	36	Birkdale	Rd.	3		Tracy Sloan		36 Birkdale Rd.	Chktg., NY 14225
72	91.06-6-21	4	Birkdale	Rd.	3		Jeswald J. & Barbara Jacobbi		4 Birkdale Rd.	Chktg., NY 14225-1616
73	91.06-6-12	40	Birkdale	Rd.	1		Timothy M. Commiskey	Terry J. Commiskey	40 Birkdale Rd.	Chktg., NY 14225-1616
74	91.06-6-11	44	Birkdale	Rd.	4		Louis V. Rera		44 Birkdale Rd.	Chktg., NY 14225-1616
75	91.06-7-32	49	Birkdale	Rd.	2		Marilynn J. Forcucci		49 Birkdale Rd.	Chktg., NY 14225-1615
76	91.06-7-21	5	Birkdale	Rd.	6		Iris D. Reese		5 Birkdale Rd.	Chktg., NY 14225-1615
77	91.06-6-9	52	Birkdale	Rd.	2		Charlene M. Brian		52 Birkdale Rd.	Chktg., NY 14225-1616
78	91.06-7-33	53	Birkdale	Rd.	1		Matthew E. Brandel		53 Birkdale Rd.	Chktg., NY 14225
79	91.06-6-8	56	Birkdale	Rd.	1	2	Jody M. Logan		56 Birkdale Rd.	Chktg., NY 14225-1616

Attachment: Sidewalk list 5-19-14-05122014040238 (RES-2014-320 : Order Replacement of Sidewalks)

	A	B	C	D	E	F	H	I	L	O
1	print key	loc st n br	loc st name	loc m ail st suff	Blocks (walk)	App- roach	Owner Name	2-Owner Name	Address	City/State/Zip
80	91.06-7-34	57	Birkdale	Rd.	1		David Jabar		57 Birkdale Rd.	Chktg., NY 14225
81	91.06-6-7	60	Birkdale	Rd.	1		Jeannette Meyers		88 Guilford Ln., Apt. B	Buffalo, NY 14221-2554
82	91.06-7-35	61	Birkdale	Rd.	5		Michael Tucholski & 1		61 Birkdale Rd.	Chktg., NY 14225-1615
83	91.06-6-6	64	Birkdale	Rd.	6		George C. & Donna Amos		64 Birkdale Rd.	Chktg., NY 14225-1616
84	91.06-7-36	65	Birkdale	Rd.	1	1	Scott J. Tempeny		65 Birkdale Rd.	Chktg., NY 14225
85	91.06-6-5	68	Birkdale	Rd.	1		Shannon K. Honan		68 Birkdale Rd.	Chktg., NY 14225-1616
86	91.06-6-4	72	Birkdale	Rd.	1		Pearl Jaglowski		72 Birkdale Rd.	Chktg., NY 14225-1616
87	91.06-7-38	73	Birkdale	Rd.	1		Lynn A. Reid		73 Birkdale Rd.	Chktg., NY 14225-1615
88	91.06-6-3	76	Birkdale	Rd.	11		Jonathan P. Mozg		76 Birkdale Rd.	Chktg., NY 14225
89	91.06-7-1	77	Birkdale	Rd.	7		Thomas J. Jachimiak	Paula G. Jachimiak	77 Birkdale Rd.	Chktg., NY 14225-1615
90	91.06-6-20	8	Birkdale	Rd.	2		Norman Kelsey		8 Birkdale Rd.	Chktg., NY 14225-1616
91	91.06-4-10	94	Birkdale	Rd.	2	2	Ester C. Okoniewski		94 Birkdale Rd.	Chktg., NY 14225-1602
92	91.06-9-20	97	Birkdale	Rd.	4		Alexander Pikula	Nancy A. Green	97 Birkdale Rd.	Chktg., NY 14225-1601
93	80.18-13-12	450	Mapleview	Rd.	3		Shirley F. Ostrowski	Karen M. Brzezicki	450 Mapleview Rd.	Chktg., NY 14225
94	80.18-12-1.11	735	Cleveland	Dr.	9		Cleveland Dr United	Presbyterian Church	735 Cleveland Dr.	Chktg., NY 14225-1113

Attachment: Sidewalk list 5-19-14-05122014040238 (RES-2014-320 : Order Replacement of Sidewalks)

TOWN OF CHEEKTOWAGA CENTRAL GARAGE

Kevin E. Gozdziaik
General Crew Chief

Thomas Carney
Automotive Crew Chief

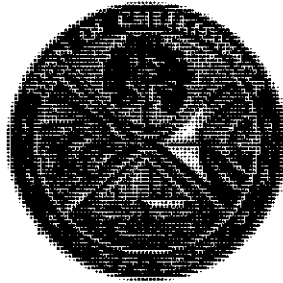

Vehicles to be auctioned 2014

#1	1961 Fork Truck Model # FK3 Serial #15443	Central Garage
#2	1999 Ford F-550 VIN# 1FDAF56S6XEC88	Sanitation
#3	2010 Ford Crown Vic VIN# 2FABP7BVOAX132965	Police
#4	2009 Ford Crown Vic VIN# 2FAHP71V89X138374	Police
#5	2003 Ford Expedition VIN # 1FMPU16L33LA67443	Police
#6	2002 Chevrolet Tahoe VIN# 1GNEK13Z42J307305	Police
#7	1997 GMC Yukon VIN# 1GKEK13R4VJ734727	Police
#8	2006 Ford Crown Vic VIN# 2FAHP71W26X149178	Police
#9	2001 Jeep Grand Cherokee VIN#1J4GW48N81C536614	Police
#10	2001 Ford Taurus VIN# 1FAFP53U11G161330	Police
#11	1998 Chevrolet Lumina VIN# 2G1WL52M9W9290230	Police
#12	1997 Chevrolet Suburban VIN# 1GCGK26RXVJ388074	Police
#13	2002 Taurus VIN# 1FAFP53U82G151623	Police
#14	2004 Ford Crown Vic VIN# 2FAHP71W74X157614	Police
#15	2001 Chevrolet Cavalier VIN# 1G1JC524317325090	Pool

Attachment: Vehicles to be Auctioned 2014 (RES-2014-331 : Authorize Auction of Surplus Vehicles and Equipment)

#16	1999 Ford Taurus VIN# 1FAFP52U6XG317050	Pool
#17	2000 Ford Explorer VIN# 1FMZU72EOYZC42254	Engineering
#18	2001 Chevrolet Cavalier VIN#1G1JC524717325190	Pool
#19	2001 Ford Taurus VIN# 1FAFP52U61G126963	Pool

3175 UNION ROAD • CHEEKTOWAGA, NY 14227 • 716-686-3439 • FAX 716-686-3904



Town of Cheektowaga

Work Session

~ Minutes ~

3301 Broadway
Cheektowaga, NY 14227
<http://www.town.cheektowaga.ny.us>

Alice Magierski
716-686-3400

Tuesday, May 27, 2014

6:00 PM

Council Office

I. Call to Order

6:00 PM Meeting called to order on May 27, 2014 at Council Office, Conference Room, Cheektowaga, NY.

Attendee Name	Organization	Title	Status	Arrived
Mary Holtz	Town of Cheektowaga	Supervisor	Absent	
James P. Rogowski	Town of Cheektowaga	Councilmember	Present	
Gerald Kaminski	Town of Cheektowaga	Councilmember	Present	
Angela M. Wozniak	Town of Cheektowaga	Councilmember	Present	
Diane Benczkowski	Town of Cheektowaga	Councilmember	Present	
Timothy J. Meyers	Town of Cheektowaga	Councilmember	Present	

2. Additional Attendees

Brian Krause, Director of Finance and Administration

Kevin Schenk, Town Attorney

II. Resolutions



1. RESOLUTION 2014-333

Award 2014 Contract Grass Cutting for Privately-Owned Properties in the Town of Cheektowaga (BID 2014-22)

Sponsored By: Councilmember Kaminski, Councilmember Benczkowski

WHEREAS, in order to enforce New York State and Local Property Maintenance Codes, the Town of Cheektowaga Office of Neighborhood Preservation has been requested to procure grass cutting and trimming, removal of the accumulated debris on various privately-owned parcels in the Town of Cheektowaga (Bid 2014-22); and

WHEREAS, in accordance with the Procurement Policy of the Town of Cheektowaga, the Office of Neighborhood Preservation issued a Notice to Bidders for Furnishing Equipment and Operators for the Grass Cutting and Trimming, Removal of the Accumulated Debris on Select Parcels in the Town of Cheektowaga for the Year 2014; and

WHEREAS, responses to said bid request were referred to the Director of Community Development and Town Attorney for analysis, tabulation and report; and

WHEREAS, based on the proposals submitted, the Director of Community Development has recommended that this Town Board award the contract for Furnishing Equipment and Operators for the Grass Cutting and Trimming, Removal of the Accumulated Debris on Select Parcels in the Town of Cheektowaga for the Year 2014 to Smaz Enterprise, for its submission of a proposal to perform said services; NOW, THEREFORE, BE IT

RESOLVED, that the contract for Furnishing Equipment and Operators for the Grass Cutting and Trimming, Removal of the Accumulated Debris on Select Parcels in the Town of Cheektowaga for the Year 2014 be awarded to Smaz Enterprise, 38 Old Farm Road, Depew, New York, 14043, for the prices listed in its proposal, said amount being the lowest responsible bid meeting the requirements of the specifications for said services; and BE IT FURTHER

RESOLVED, that the Supervisor be and hereby is directed and authorized to execute a contract with Smaz Enterprise for the aforesaid services, subject to approval by the Town Attorney.

RESULT:	ADOPTED [UNANIMOUS]
MOVER:	Gerald Kaminski, Councilmember
SECONDER:	Diane Benczkowski, Councilmember
AYES:	Rogowski, Kaminski, Wozniak, Benczkowski, Meyers
ABSENT:	Mary Holtz



Town of Cheektowaga

Regular Meeting

~ Minutes ~

3301 Broadway
Cheektowaga, NY 14227
<http://www.town.cheektowaga.ny.us>

Alice Magierski
716-686-3400

Monday, June 2, 2014

6:45 PM

Council Chambers

I. Call to Order

6:45 PM Meeting called to order on June 2, 2014 at Council Chambers, 3301 Broadway St, Cheektowaga, NY.

Attendee Name	Organization	Title	Status	Arrived
Mary Holtz	Town of Cheektowaga	Supervisor	Present	
James P. Rogowski	Town of Cheektowaga	Councilmember	Present	
Gerald Kaminski	Town of Cheektowaga	Councilmember	Present	
Angela M. Wozniak	Town of Cheektowaga	Councilmember	Present	
Diane Benczkowski	Town of Cheektowaga	Councilmember	Present	
Timothy J. Meyers	Town of Cheektowaga	Councilmember	Present	

2. Additional Attendees

Thomas Adamczak, Supervising Building and Plumbing Inspector
Lt. Steven Berez, Police Department
Stanley Kaznowski, III, Planning Board Chairman
Carla A. Kosmerl, Director of Community Development
William Pugh, Town Engineer
Kevin Schenk, Town Attorney
Capt. Michael Sliwinski, Police Department

II. Public Comment Period

III. Public Hearings

1. Application for Transportation Alternatives Program Funding

COMMENTS - Current Meeting:

This being the time and place advertised for a Public Hearing, the Supervisor directed the Town Clerk to present that such notice has been duly published and posted; upon the order of the Supervisor such proof was duly filed.

The Supervisor announced that the Town Board would hear all persons interested in the subject of the hearing. Comments were heard, after which the Supervisor declared the hearing closed, decision was reserved.

RESULT: CLOSED [UNANIMOUS]
MOVER: Gerald Kaminski, Councilmember
SECONDER: Mary Holtz, Supervisor
AYES: Holtz, Rogowski, Kaminski, Wozniak, Benczkowski, Meyers

2. Amend Landlord Licensing Law

COMMENTS - Current Meeting:

This being the time and place advertised for a Public Hearing, the Supervisor directed the Town Clerk to present that such notice has been duly published and posted; upon the order of the Supervisor such proof was duly filed.

The Supervisor announced that the Town Board would hear all persons interested in the subject of the hearing. Comments were heard, after which the Supervisor declared the hearing closed, decision was reserved.

RESULT: CLOSED [UNANIMOUS]
MOVER: Diane Benczkowski, Councilmember
SECONDER: Mary Holtz, Supervisor
AYES: Holtz, Rogowski, Kaminski, Wozniak, Benczkowski, Meyers

IV. Resolutions



1. RESOLUTION 2014-334

Warrant

Sponsored By: Supervisor Holtz, Councilmember Kaminski

BE IT RESOLVED, that the following Vouchers & Warrants submitted to the Town of Cheektowaga prior to June 2, 2014 are hereby approved and made part hereof;

GENERAL FUND	\$284,404.50
RISK RETENTION FUND	83,678.87
NYS HOME PROGRAM	
DEBT	
HUD HOUSING REHABILITATION FUND	
SPECIAL DISTRICTS FUND	49,596.41
HIGHWAY FUND	62,617.14
CAPITAL FUND	45,650.37
TRUST & AGENCY FUND	20.00
HUD CDBG FUND	1,302.32
PART TOWN FUND	969.95
NYS AFFORDABLE HOUSING	
	\$528,239.56

RESULT:	ADOPTED [UNANIMOUS]
MOVER:	Mary Holtz, Supervisor
SECONDER:	Gerald Kaminski, Councilmember
AYES:	Holtz, Rogowski, Kaminski, Wozniak, Benczkowski, Meyers



2. RESOLUTION 2014-335

Award of Bid - Roof Replacement on Town Hall Additions (Bid #2014-24)

Sponsored By: Supervisor Holtz, Councilmember Kaminski

WHEREAS, a Notice to Bidders was published for the receipt of bids for Roof Replacement on Town Hall Additions (Bid 2014-24), which bids were duly received and opened by the Town Clerk on May 21, 2014, AND

WHEREAS, said bids were referred to the Town Engineer for analysis, tabulation and report, which is contained in a letter from the Engineering Department dated May 28, 2014, AND

WHEREAS, said letter recommends that the contract for the Roof Replacement on Town Hall Additions be awarded to Murray Roofing Company, Inc. for their submission of the lowest bid meeting the requirements of the specifications, NOW, THEREFORE, BE IT

RESOLVED, that the bid for the Roof Replacement on Town Hall Additions be and hereby is awarded to:

Murray Roofing Company, Inc.
600 Cayuga Creek Road
Cheektowaga, New York 14227

for their total bid price of \$50,000.00, said bid being the lowest bid meeting the requirements of the specifications and construction drawings, AND, BE IT FURTHER

RESOLVED, that the Supervisor, on behalf of this Town Board, be and hereby is directed and authorized to execute the contract with Murray Roofing Company, Inc. for the aforesaid project, AND, BE IT FURTHER

RESOLVED, that funding for said project shall be chargeable to Account #500-1910-2531-5329.

RESULT:	ADOPTED [UNANIMOUS]
MOVER:	Mary Holtz, Supervisor
SECONDER:	Gerald Kaminski, Councilmember
AYES:	Holtz, Rogowski, Kaminski, Wozniak, Benczkowski, Meyers



3. RESOLUTION 2014-336

Notice to Bidders - One New and Unused 20 H.P. Submersible Non-Clog Wastewater Pump (Bid #2014-25)

Sponsored By: Councilmember Meyers, Supervisor Holtz

WHEREAS, it is in order that bids be advertised for the furnishing of one (1) new and unused 20 H.P. Submersible Non-Clog Wastewater Pump for the Sewer Maintenance Department (Bid 2014-25), AND

WHEREAS, the Engineering Department has prepared specifications for said pump, NOW, THEREFORE, BE IT

RESOLVED, that the Town Clerk be directed to publish a Notice to Bidders for the furnishing of one (1) new and unused 20 H.P. Submersible Non-Clog Wastewater Pump, said notice to be published in the CHEEKTOWAGA BEE, AND, BE IT FURTHER

RESOLVED, that sealed bids will be received on the 18th day of June, 2014 at 11:00 am at a public bid opening to be held in the Council Chambers in the Cheektowaga Town Hall.



NOTICE TO BIDDERS

Sealed proposals will be received and considered by the Town Board of the Town of Cheektowaga on June 18, 2014 at 11:00 am, local time, at the Town Hall, corner of Broadway and Union Roads, for the furnishing of one (1) new and unused 20 H.P. Submersible Non-Clog Wastewater Pump for the Sewer Maintenance Department (Bid 2014-25).

Information for bidders and specifications may be obtained from the Office of the Town Clerk in Town Hall.

The Town Board reserves the right to consider informal any bid not prepared and submitted in accordance with the provisions of the specifications and contract documents, and may waive any informalities, make an award to other than the low bidder, should it be in the best interest of the Town, or reject any and all bids.

By order of the Town Board of the Town of Cheektowaga, Erie County, New York.

Alice Magierski, Town Clerk

DATED: June 2, 2014

RESULT:	ADOPTED [UNANIMOUS]
MOVER:	Timothy J. Meyers, Councilmember
SECONDER:	Mary Holtz, Supervisor
AYES:	Holtz, Rogowski, Kaminski, Wozniak, Benczkowski, Meyers



4. RESOLUTION 2014-337

Notice to Bidders - Rehabilitation of the Rein Road Bridge Spanning Ellicott Creek (Bid #2014-28)

Sponsored By: Supervisor Holtz, Councilmember Kaminski

WHEREAS, the preparation of plans and specifications for the Rehabilitation of the Rein Road Bridge Spanning Ellicott Creek, PIN 5758.38, BIN 2212970 have been completed by the Project Engineering Consulting firm of Greenman Pederson, Inc. enabling the solicitation of competitive bids in accordance with New York State Department of Transportation guidelines and procedures for Locally Administered Federal Aid Projects (Bid 2014-28), NOW, THEREFORE, BE IT

RESOLVED, that the Town Clerk be directed to publish a Notice to Bidders for the aforesaid project, said notice to be published in the CHEEKTOWAGA BEE and in the NEW YORK STATE CONTRACT REPORTER, AND, BE IT FURTHER

RESOLVED, that sealed bids will be received on the 2nd day of July, 2014 at 11:00 am, local time, at a public bid opening to be conducted by the Town Clerk in the Council Chambers at the Cheektowaga Town Hall.



NOTICE TO BIDDERS

NOTICE IS HEREBY GIVEN that sealed proposals will be received by the Town Board of the Town of Cheektowaga until 11:00 am, local time, on the **2nd day of July, 2014**. All bids will be publicly opened and read at 11:00 am at the Town Hall, 3301 Broadway, Cheektowaga, New York 14227 for furnishing all tools, equipment, materials, and labor for the **Rehabilitation of the Rein Road Bridge, BIN 2212970, PIN 5758.38**, and all related work, complete in place, tested and ready for use in accordance with the Contract Documents (Bid 2014-28).

All proposals shall be submitted on the forms furnished herein and the entire volume, including any addenda, shall be submitted in a sealed envelope and addressed to the Town of Cheektowaga, 3301 Broadway, Cheektowaga, New York 14227, to the attention of Alice Magierski, Town Clerk, and shall have the contractor's name and title of the bid. Bids for contracts shall be designated as **Rehabilitation of the Rein Road Bridge, BIN 2212970, PIN 5758.38**.

Copies of the proposed Contract Documents, Plans and Specifications may be examined at the Town Clerk's Office, Town Hall, 3301 Broadway, Cheektowaga, New York 14227 and at the office of Greenman-Pedersen, Inc., 4950 Genesee Street, Cheektowaga, NY 14225. Documents are also on file at Construction Exchange, 2660 William Street, Cheektowaga, NY 14227. Copies may be purchased from the Town Clerk's Office and can be obtained upon payment of \$50.00 in the form of one (1) check made payable to the Town of Cheektowaga for each copy requested. The Owner will not be responsible for full or partial sets of Contract Documents, including any Addenda, obtained from any other source.

Any bidder returning such Plans and Specifications in good condition within ten (10) business days following the bid opening will be refunded the full amount of the deposit. Deposit will not be refunded for non-bidders. Material suppliers and anyone returning the Plans and Specifications before the bid opening will be classified as non-bidders. Any bidders requesting more than one (1) set of Plans and Specifications may purchase the excess, but it is understood that these are non-refundable.

Each proposal must be accompanied by a certified check payable to the Town of Cheektowaga, or bid bond, having as surety thereon a surety company acceptable to the Town Attorney, in an amount not less than five percent (5%) of the amount of the base bid, conditioned that, if his proposal is accepted, he will enter into a contract for the same, and that he will execute any such further security as may be required for the faithful performance of the contract.

Attention of bidders is particularly called to the requirements as to condition of employment to be observed and minimum wage rates to be paid under the contract.

The Owner reserves the right to reject any or all bids for failure to comply with the requirements of the Contract Documents but may, at its discretion, waive any informalities or irregularities.

The work shall commence no later than five (5) days after the "Notice to Proceed" has been issued and the work shall be completed no later than November 30, 2014.

By Order of: THE TOWN OF CHEEKTOWAGA

Alice Magierski, Town Clerk

DATED: June 2, 2014

PUBLISHED: June 05 and 12, 2014

RESULT:	ADOPTED [UNANIMOUS]
MOVER:	Mary Holtz, Supervisor
SECONDER:	Gerald Kaminski, Councilmember
AYES:	Holtz, Rogowski, Kaminski, Wozniak, Benczkowski, Meyers



5. RESOLUTION 2014-338

Authorize Purchase of Under-the-Door Camera for Police Department

Sponsored By: Councilmember Benczkowski, Councilmember Kaminski

4th WHEREAS, the Cheektowaga Police Department was awarded a grant through New York State Division of Homeland Security and Emergency Services (New York State Hazardous Incident Response Equipment ("HIRE")); and

WHEREAS, the grant, in the amount of \$13,712.00, was awarded for the purchase of an under-the-door scope and camera; and

WHEREAS, the camera slides under doors in less than a quarter inch of space, which will enable the Police Tactical Team (SWAT) to see behind walls, ceilings, floors, and a variety of barriers to covertly monitor activity in an adjacent room and/or perform covert surveillance, thus allowing assessment of potential threats or activity prior to proceeding with action without alerting anyone inside; and

WHEREAS, this equipment provides an additional measure of security and safety for our Police tactical teams; and

WHEREAS, Zistos Corporation, 1736 Church Street, Holbrook, New York, offers New York State pricing under New York State Contract #PC-63617, Group 38232, for the purchase of said equipment; and

WHEREAS, the total cost for the under-the-door camera and related items is \$14,862.75 (\$13,712.00 of same being the grant allowance); and

WHEREAS, the Cheektowaga Police Department will pay the remaining balance of \$1,150.75 from Police Asset Forfeiture Line #600-0600-0881; NOW, THEREFORE, BE IT

RESOLVED, that this Town Board hereby authorizes the purchase of the under-the-door camera and necessary related equipment from Zistos Corporation, 1736 Church Street, Holbrook, New York; and be it further

RESOLVED, that the Supervisor is hereby authorized to execute any documents necessary to effectuate this purchase.

RESULT:	ADOPTED [UNANIMOUS]
MOVER:	Diane Benczkowski, Councilmember
SECONDER:	Gerald Kaminski, Councilmember
AYES:	Holtz, Rogowski, Kaminski, Wozniak, Benczkowski, Meyers



6. RESOLUTION 2014-339

Special Event - German Festival

Sponsored By: Councilmember Rogowski, Councilmember Meyers

WHEREAS, by resolution dated May 1, 1995, this Town Board adopted a Special Events policy, which requires anyone wishing to hold a special event in the Town to file an application and supporting documentation, fees, etc. to the Town Clerk prior to the special event, and

WHEREAS, the Federation of German-American Societies has made application to hold its annual German Festival & Car Show in Cheektowaga Town Park Lions Pavilion on Saturday, August 30th and Sunday, August 31st, 2014; and

WHEREAS, this Board has reviewed the aforementioned application, which application has been approved by the Police Department, Facilities Department, and Youth and Recreational Services, and has no objection to same, and

WHEREAS, due to the nature of the event, this Town Board hereby waives the following requirements:

1. Submittal of plan for sanitary facilities;
2. Submittal of site plan;
3. Submittal of Security Plan;
4. Submittal of Fire Prevention/Emergency Services Plan;

NOW, THEREFORE, BE IT

RESOLVED, that this Town Board hereby approves the aforementioned application of the Federation of German-American Societies for the aforementioned German Festival & Car Show to be held in Cheektowaga Town Park on Saturday, August 30th and Sunday, August 31st, 2014.

RESULT:	ADOPTED [UNANIMOUS]
MOVER:	James P. Rogowski, Councilmember
SECONDER:	Timothy J. Meyers, Councilmember
AYES:	Holtz, Rogowski, Kaminski, Wozniak, Benczkowski, Meyers



7. RESOLUTION 2014-340

Special Event - Co-ed Softball Tournament

Sponsored By: Councilmember Rogowski, Councilmember Meyers

WHEREAS, by resolution dated May 1, 1995, this Town Board adopted a Special Events policy, which requires anyone wishing to hold a special event in the Town to file an application and supporting documentation, fees, etc. to the Town Clerk prior to the special event, and

WHEREAS, the HSBC Sports and Social Club has made application to hold its Softball Tournament in Stiglmeier Park on Saturday, August 9th, 2014 from 7:00 a.m. to 7:00 p.m.; and

WHEREAS, this Board has reviewed the aforementioned application, which application has been approved by the Facilities Department and the Youth and Recreation Department, and has no objection to same, and

WHEREAS, due to the nature of the event, this Town Board hereby waives the following requirements:

- . Submittal of plan for sanitary facilities;
- . Submittal of site plan;
- . Submittal of Security Plan;
- . Submittal of Fire Prevention/Emergency Services Plan;

NOW, THEREFORE, BE IT

RESOLVED, that this Town Board hereby approves the aforementioned application of the HSBC Sports and Social Club for the aforementioned Softball Tournament to be held in Stiglmeier Park on Saturday, August 9th, 2014.

RESULT:	ADOPTED [UNANIMOUS]
MOVER:	James P. Rogowski, Councilmember
SECONDER:	Timothy J. Meyers, Councilmember
AYES:	Holtz, Rogowski, Kaminski, Wozniak, Benczkowski, Meyers



8. RESOLUTION 2014-341

Special Event - NCAAAA Baseball Parade

Sponsored By: Councilmember Meyers, Councilmember Rogowski

WHEREAS, by resolution dated May 1, 1995, this Town Board adopted a Special Events policy, which requires anyone wishing to hold a special event in the Town to file an application and supporting documentation, fees, etc. To the Town Clerk prior to the special event; and

WHEREAS, the North Cheektowaga Amateur Athletic Association (NCAA) has made application to hold its Baseball Parade on Saturday, June 7th, 2014, at 11:30 a.m., said parade to begin on Nagel Drive, to George Urban Boulevard through Tops parking lot, proceeding to ball diamonds ; and

WHEREAS, this Board has reviewed the aforementioned application, which application has been approved by the Police Department, the Department of Youth and Recreation, and the Facilities Department, and has no objection to same; and

WHEREAS, due to the nature of the event, this Town Board hereby waives the following requirements:

1. Submittal of plan for sanitary facilities;
2. Submittal of site plan;
3. Requirement that application be made at least 60 days prior to the date of the special event;
4. Submittal of Security Plan;
5. Submittal of Fire Prevention/Emergency Services Plan;

NOW, THEREFORE, BE IT

RESOLVED, that this Town Board hereby approves the application of North Cheektowaga Amateur Athletic Association for the aforementioned Parade, to be held on Saturday, June 7th, 2014 at 11:30 a.m.; BE IT FURTHER

RESOLVED, that the Chief of Police be and hereby is directed to provide traffic safety and escort services for such parade and to ensure compliance with Section 1660(a)(6) of the Vehicle and Traffic Law.

RESULT:	ADOPTED [UNANIMOUS]
MOVER:	Timothy J. Meyers, Councilmember
SECONDER:	James P. Rogowski, Councilmember
AYES:	Holtz, Rogowski, Kaminski, Wozniak, Benczkowski, Meyers



9. RESOLUTION 2014-342

Fitness in the Park - YMCA

Sponsored By: Councilmember Wozniak, Councilmember Rogowski

WHEREAS, the Department of Youth and Recreational Services is desirous of holding a "Fitness in the Park" program in partnership with the YMCA Buffalo Niagara from June 24th thru August 28th, 2014 and

WHEREAS, said program will be held in Cheektowaga Town Park each Tuesday and Thursday during the summer for people of all ages and at no cost to the Town, NOW,
THEREFORE BE IT

RESOLVED, that upon approval by the Town Attorney, the Supervisor be and hereby is authorized and directed to execute an agreement with the YMCA Buffalo Niagara.

RESULT:	ADOPTED [UNANIMOUS]
MOVER:	Angela M. Wozniak, Councilmember
SECONDER:	James P. Rogowski, Councilmember
AYES:	Holtz, Rogowski, Kaminski, Wozniak, Benczkowski, Meyers



10. RESOLUTION 2014-343

Unsafe-Unsecured/16 Hoerner Avenue

Sponsored By: Councilmember Benczkowski, Supervisor Holtz

WHEREAS, Town of Cheektowaga Law for the Administration and Enforcement of the Codes of New York State; and the Property Maintenance Code of New York State require that all vacant structures and premises shall be maintained in clean, safe, secure and sanitary conditions so as not to cause a blighting problem or adversely affect the public health or safety and all nuisances abated, AND

WHEREAS, the Town of Cheektowaga has received notification of an unsafe structure and premises located at 16 Hoerner Avenue, Cheektowaga, New York SBL# 101.60-4-19 that is a danger to the safety of others, and records kept by the Assessors Office identify Tammy Capone-Cummings & Chris Cummings, 86 David Avenue, Cheektowaga, New York 14225, as the owner AND

WHEREAS, an inspection of such premises was conducted at 16 Hoerner Avenue, by the Housing and Neighborhood Preservation Office, AND

WHEREAS, such inspection found the premises to be deteriorated, vacant, a hazard, and a danger to the safety and well being of others, AND

WHEREAS, the Town of Cheektowaga Housing and Neighborhood Preservation Office properly notified the property owner in accordance with the Town of Cheektowaga Law for the Administration and Enforcement of the Codes of New York State, and the owner failed to take actions to safeguard the premises, AND

WHEREAS, these conditions require the Town of Cheektowaga Housing and Neighborhood Preservation Office to take immediate steps to safeguard the premises to protect the health and safety of others and abate all nuisances, NOW, THEREFORE BE IT

RESOLVED, that pursuant to Section 70-7A.(5) and Section 70-8 of the Town of Cheektowaga Law for the Administration and Enforcement of the Codes of New York State that the vacant structure premises be safeguarded and all nuisances abated; and all costs incurred be assessed against the property hereinbefore described.

RESULT:	ADOPTED [UNANIMOUS]
MOVER:	Diane Benczkowski, Councilmember
SECONDER:	Mary Holtz, Supervisor
AYES:	Holtz, Rogowski, Kaminski, Wozniak, Benczkowski, Meyers



11. RESOLUTION 2014-344

Youth & Recreation Terminations

Sponsored By: Councilmember Wozniak, Councilmember Rogowski

BE IT RESOLVED that the individuals listed below be and hereby are terminated in the Department of Youth & Recreational Services effective as indicated:

Nicholas Coronado	Never worked	14225
Sara Piwowarski	Never worked	14043
Joseph Malicki	Never worked	14043

RESULT:	ADOPTED [UNANIMOUS]
MOVER:	Angela M. Wozniak, Councilmember
SECONDER:	James P. Rogowski, Councilmember
AYES:	Holtz, Rogowski, Kaminski, Wozniak, Benczkowski, Meyers



12. RESOLUTION 2014-345

Youth & Recreation Transfers

Sponsored By: Councilmember Wozniak, Councilmember Rogowski

BE IT RESOLVED that the individuals listed below be and hereby transferred, as indicated, in the Department of Youth & Recreational Services, effective immediately:

Lifeguard "Level II" - 7180.1903 - \$9.18 - Regular Part-time

Samuel Alfonso
Jeffrey Creighton
Natalie Lane
Michael Terranova

Recreation Instructor "Head Lifeguard Maryvale Pool" - 7180.1902 - \$9.74 - Regular Part-time

Jacob Radlich

Lifeguard "Level III" - 7180.1903 - \$9.36 - Regular Part-time

Tyler Kunkel
James Rogers

Recreation Specialist "Pool Director" - 7180.1902 - \$20.53 - Regular Part-time

Catherine Giles

Recreation Instructor "Swim Lesson/Special Events Coordinator" - 7180.1902 - \$13.25

Regular Part-time

Sean Kunkel

Recreation Instructor "Town Park Pool Supervisor 1st Shift Level VI" - \$11.97 -

Regular Part-time

Jeffery Kunkel

Lifeguard "Level IV" - 7180.1903 to Recreation Instructor "Head Lifeguard - Dingens" -

7180.1902 - \$9.74 - Seasonal

Kayla Doetterl

RESULT:	ADOPTED [UNANIMOUS]
MOVER:	Angela M. Wozniak, Councilmember
SECONDER:	James P. Rogowski, Councilmember
AYES:	Holtz, Rogowski, Kaminski, Wozniak, Benczkowski, Meyers



13. RESOLUTION 2014-346

Youth & Recreation Hiring

Sponsored By: Councilmember Wozniak, Councilmember Rogowski

BE IT RESOLVED that the individuals listed below be and hereby are hired, as indicated, in the Department of Youth & Recreational Services, effective immediately:

Recreation Attendant - 7310.1814 - \$8.15 - Regular Part-time

Nicholas Russell 14227

Laborer - "Bathhouse Attendant - Level I" - 7180.1901 - \$8.00 - Seasonal

Anthony Albright 14225

Shannon Borowiak 14227

Freddy Drzewiecki III 14225

Jessie Farris 14212

Kira Herkey 14225

Zachary Jones 14225

Kyle Kaminski 14227

Alexis Krueger 14215

Felicia Magnuszewski 14043

Andrew Matulich 14225

Megan McIntosh 14225

Haley Muelbauer 14225

Nathan Pazderski 14227

Allysa Walker 14225

Nakira White 14225

Madeline Wnuk 14043

Laborer - "Bathhouse Attendant - Level II" - 7180.1901 - \$8.15 - Seasonal

Michael Sokol 14227

Recreation Instructor - "Maryvale Pool Supervisor" - 7180.1902 - \$10.58 - Seasonal

Joshua Atzrott 14215

Lifeguard - Level I - 7180.1903 - \$9.00 - Seasonal

Adrianna Johnson 14225

Lifeguard - Level IV - 7180.1903 - \$9.55 - Seasonal

Raena Koepfel 14225

Recreation Attendant - 7140.1645 & 7140.1614 - \$8.25 - Regular Part-time

Brittany Talani 14227

Recreation Attendant - 7140.1648 & 7140.1614 - \$8.25 - Regular Part-time

Cassidy Bobeck 14225

Recreation Attendant - 7140.1648 - \$8.00 - Seasonal

Lennox Melin 14206

Recreation Attendant - 7140.1645 - \$8.25 - Seasonal

Zoe Obstarczyk 14211
Tyler Welsh 14225

Recreation Aide - 7140.1648 - \$8.00 - Part-time

Anthone' Proctor 14225
Jessica Woods 14225

Recreation Aide - 7140.1648 & 7140.1614 - \$8.00 - Part-time

Molly Wittig 14043

RESULT: ADOPTED [UNANIMOUS]
MOVER: Angela M. Wozniak, Councilmember
SECONDER: James P. Rogowski, Councilmember
AYES: Holtz, Rogowski, Kaminski, Wozniak, Benczkowski, Meyers



14. RESOLUTION 2014-347

Hiring/Termination of Part Time/Seasonal Employees

Sponsored By: Councilmember Kaminski, Supervisor Holtz

BE IT RESOLVED, that the following individuals be and hereby are hired as **SEASONAL EMPLOYEES**, not to exceed five (5) months in a calendar year, in the various departments listed and in compliance with Civil Service Laws and Regulations as well as the provisions of the Town's collective bargaining agreement between the Town of Cheektowaga and the Town of Cheektowaga Employees Association:

SANITATION DEPARTMENT Laborer \$9.25/hour effective 5/19/14
Sharrone M. Johnson, Cheektowaga, New York
Tyler D. Schaf, Cheektowaga, New York
David A. Oryszak, Jr., Cheektowaga, New York

SANITATION DEPARTMENT Laborer \$9.25/hour effective 5/20/14
Christopher M. Vail, Depew, New York

FACILITIES DEPARTMENT Laborer \$8.25/hour effective 5/27/14
Tyler M. Elis, Cheektowaga, New York

BE IT RESOLVED, that the following seasonal and/or part-time employees be and hereby are terminated as listed:

SANITATION DEPARTMENT
David A. Oryszak, Jr. effective 5/20/14
Mark P. Mez effective 6/1/14

JUSTICE COURT
Jill Baszczyński effective 5/31/14

BE IT RESOLVED, that following employees' status be and hereby is amended as follows:

RECORDS MANAGEMENT to TOWN CLERK'S OFFICE Clerk (Part Time) \$9.00/hour effective 6/26/14
Evelyn Adamski, Cheektowaga, New York

RECORDS MANAGEMENT Clerk (Part Time) \$11.25/hour effective 6/26/14
Joseph S. Fedyna, Cheektowaga, New York

RECORDS MANAGEMENT Clerk (Part Time) \$9.00/hour effective 6/26/14
Sandra J. Fetter, Cheektowaga, New York
Carol Brunner, Cheektowaga, New York
Maria A. Ross, Cheektowaga, New York

RESULT: **ADOPTED [UNANIMOUS]**
MOVER: Gerald Kaminski, Councilmember
SECONDER: Mary Holtz, Supervisor
AYES: Holtz, Rogowski, Kaminski, Wozniak, Benczkowski, Meyers



15. RESOLUTION 2014-348

Appointment of Park Maintenance Worker I (Temporary) Facilities Department/Mark P. Mez

Sponsored By: Councilmember Rogowski, Councilmember Kaminski

WHEREAS, a temporary vacancy exists in the title of Park Maintenance Worker I in the Facilities Department (Parks Division); AND

WHEREAS, notice of said vacancy has been posted in accordance with the provisions of the Town's collective bargaining agreement with the Town of Cheektowaga Employees Association; AND

WHEREAS, Mark P. Mez, currently a seasonal Laborer in the Sanitation Department, applied for said position and meets the necessary qualifications for appointment; NOW, THEREFORE, BE IT

RESOLVED, that Mark P. Mez of Cheektowaga, New York, be and hereby is appointed to the temporary position of Park Maintenance Worker I in the Facilities Department (Parks Division) in accordance with the terms and conditions of the Town's collective bargaining agreement with the Town of Cheektowaga Employees Association effective June 2, 2014.

RESULT:	ADOPTED [UNANIMOUS]
MOVER:	James P. Rogowski, Councilmember
SECONDER:	Gerald Kaminski, Councilmember
AYES:	Holtz, Rogowski, Kaminski, Wozniak, Benczkowski, Meyers



16. RESOLUTION 2014-349

Appointment of Laborer (Temporary) Highway Department/Scott R. Fullington

Sponsored By: Councilmember Kaminski, Supervisor Holtz

WHEREAS, a temporary vacancy exists in the title of Laborer in the Highway Department; AND

WHEREAS, notice of said vacancy has been posted in accordance with the provisions of the Town's collective bargaining agreement with the Town of Cheektowaga Employees Association; AND

WHEREAS, Scott R. Fullington, currently employed as a Park Maintenance Worker I in the Facilities Department, bid on said vacancy and meets the necessary qualifications for appointment; NOW, THEREFORE, BE IT

RESOLVED, that Scott R. Fullington of Cheektowaga, New York, be and hereby is appointed to the temporary position of Laborer in the Highway Department in accordance with the terms and conditions of the Town's collective bargaining agreement with the Town of Cheektowaga Employees Association effective June 9, 2014.

RESULT:	ADOPTED [UNANIMOUS]
MOVER:	Gerald Kaminski, Councilmember
SECONDER:	Mary Holtz, Supervisor
AYES:	Holtz, Rogowski, Kaminski, Wozniak, Benczkowski, Meyers



17. RESOLUTION 2014-350

Travel Authorization Police Department/Detective Mark Jedd

Sponsored By: Councilmember Benczkowski, Councilmember Kaminski

WHEREAS, the Motor Vehicle Theft and Insurance Fraud Statewide Work Group is being held June 17 through June 18, 2014 in Saratoga Springs, New York; AND

WHEREAS, Detective Mark Jedd has requested approval to attend said work group; AND

WHEREAS, Police Chief David Zack has submitted a request for travel authorization along with the proper paperwork in a timely manner; AND

WHEREAS, the total cost to the Town shall not exceed \$311; AND

WHEREAS, these expenses have been budgeted by the Department; NOW, THEREFORE, BE IT

RESOLVED, that Detective Mark Jedd be and hereby is authorized to attend the Motor Vehicle Theft and Insurance Fraud Statewide Work Group being held June 17 through June 18, 2014 in Saratoga Springs, New York.

RESULT:	ADOPTED [UNANIMOUS]
MOVER:	Diane Benczkowski, Councilmember
SECONDER:	Gerald Kaminski, Councilmember
AYES:	Holtz, Rogowski, Kaminski, Wozniak, Benczkowski, Meyers

V. Suspension of Rules

Motion by Councilmember Rogowski; Seconded by Councilmember Holtz to waive the rules to include the following one (1) resolution: 2014-351. Motion carried.



1. RESOLUTION 2014-351

Order Replacement of Sidewalks

Sponsored By: Councilmember Kaminski, Supervisor Holtz

WHEREAS, Chapter 210 of the Code of the Town of Cheektowaga (Streets and Sidewalks) sets forth the specifications for the construction of sidewalks in the Town of Cheektowaga, and

WHEREAS, Section 200-a of the Town Law of the State of New York authorizes a town board to adopt a local law to apportion the expense of building, relaying and repairing sidewalks in towns between the town and property owners, and

WHEREAS, this Town Board, by Local Law No. 4 of the Year 1991 and Local Law No. 5 of the Year 2008 (amended by Local Law No. 3 of the Year 2013), adopted provisions to apportion the cost of relaying or repairing sidewalks in the Town of Cheektowaga between the Town and property owners, and

WHEREAS, the Town Superintendent of Highways has supplied this Town Board with the attached list of sidewalks in the Town which are in need of repair or replacement, NOW, THEREFORE, BE IT

ORDERED, that the owners of properties on the attached list be and hereby are directed to repair/replace the sidewalks abutting such properties on or before June 30, 2014, in accordance with the Town's Streets and Sidewalks Law, and BE IT FURTHER

ORDERED, that, should such property owners neglect to or choose to not repair/replace their sidewalks as so notified before June 30, 2014, the Town will cause such sidewalks to be repaired/replaced; will pay \$46.40-51.20 for each 5-foot linear block repaired/replaced; and will assess/charge the property owner the balance over a period of five (5) years on the County/Town tax bill, with interest at the rate of 6.00 % as authorized by State law; or, at the property owner's option, payment may be made in one lump sum before September 16, 2014, and BE IT FURTHER

ORDERED, that the Town Clerk be and hereby is directed to notify the owners of properties identified on the attached list of the adoption of this Order by sending the attached Notice via certified mail to each owner at his/her/their address as it appears on the Town Assessment Roll.

NOTICE OF ADOPTION OF ORDER OF THE TOWN BOARD OF THE TOWN OF CHEEKTOWAGA

TAKE NOTICE THAT, pursuant to a resolution adopted by the Town Board of the Town of Cheektowaga on June 2, 2014,

YOU ARE HEREBY ORDERED to repair the sidewalk in front of your property.

Such work must be completed on or before **June 30, 2014.**

In the event you neglect or choose not to perform this work before the specified date, be advised that the Town of Cheektowaga shall cause such work to be done. The Town will audit and pay \$46.40-\$51.20 for each 5-foot linear block replaced; and will assess the remaining expense thereof (including interest at the rate of 6.00%) against your property in five (5) annual installments; this amount will be added to your town tax bills for the next five (5) years and shall become a lien on your property. In the alternative, you may pay your share of the cost directly to the Town provided you do so on or before September 16, 2014. You will be notified of the amount you owe for sidewalk repairs.

If the Town performs the work, it is estimated that your cost for sidewalk repair will be approximately \$69.60-\$76.80 per 5-foot linear block of sidewalk.

If you choose to perform the work yourself or have a contractor perform such work, be advised that you will be responsible for paying 100% of the cost of the sidewalk work **(the Town will not pay anything towards your cost).**

BY ORDER OF THE TOWN BOARD OF THE TOWN OF CHEEKTOWAGA, ERIE COUNTY, NEW YORK.

DATED: June 2, 2014

ALICE MAGIERSKI
Town Clerk

Attachments:

Sidewalk list June 2 2014-05292014220439 (PDF)

RESULT:	ADOPTED [UNANIMOUS]
MOVER:	Gerald Kaminski, Councilmember
SECONDER:	Mary Holtz, Supervisor
AYES:	Holtz, Rogowski, Kaminski, Wozniak, Benczkowski, Meyers

VI. Communications

A. Departmental Communications

1. **Building Permit List - May 2014**
2. **Minutes: Town Environmental Advisory Committee - April 30, 2014**
3. **Minutes: Cheekowaga Traffic Safety Commission- April 15, 2014**
4. **Minutes: Cheektowaga Public Library - Board of Trustees - May 21, 2014**
5. **Minutes: Cheektowaga Conservation Advisory Council - May 1, 2014**
6. **2013 Annual Report - Cheektowaga Public Libraries**

B. General Communications

1. Notice of Claim: Cecilia Zawierucha vs. Town of Cheektowaga

VII. Comments

A. Supervisor's Comments

B. Councilmember's Comments

C. Public Comments

VIII. Adjournment

Motion by Supervisor Holtz; Seconded by Councilmember Rogowski to adjourn the meeting at 7:55 PM

Alice Magierski, Town Clerk

print_key	loc_p refix_dir	loc_s t_nbr	loc_st_nam e	loc_mail_ st_suff	Blocks (walk)	Approach	Comments	owner_name	Zowner_name	Attention To:	Address	City/State/Zip
113.50-4-8		113	Rosemead	Ln.	2		Fairelm Side	Timothy Jason & W			113 Rosemead Ln.	Cheektowaga, NY 14227-1326
113.42-6-4		100	Fairelm	Ln.	2			Emanuel M. Galluzzo	Mary Ann Galluzzo		100 Fairelm Ln.	Cheektowaga, NY 14227
113.42-7-2		101	Fairelm	Ln.	4	1		Nathan M. Henson	Maria L. Henson		313 Kingsport Rd.	Holly Springs, NC 27540
113.50-7-2		11	Fairelm	Ln.	4			Richard S. Pulkownik	Dorothy C. Pulkownik		11 Fairelm Ln.	Cheektowaga, NY 14227-1320
113.34-3-8		110	Fairelm	Ln.	2			Renee Marzec			110 Fairelm Ln.	Cheektowaga, NY 14227
113.34-3-10		111	Fairelm	Ln.	4			Thomas H. Rummell			111 Fairelm Ln.	Cheektowaga, NY 14227-1367
113.34-3-7		112	Fairelm	Ln.	1			Mato A. Ereiz	Zelika Ereiz		112 Fairelm Ln.	Cheektowaga, NY 14227
113.34-3-9		113	Fairelm	Ln.	11		(2) Fairelm, (9) Wells Cracked w/Manhole Cover	Loretta Kadatz	Alan D. Kadatz		113 Fairelm Ln.	Cheektowaga, NY 14227-1367
113.34-3-5		116	Fairelm	Ln.	4	2		Cathreen Bhatti			116 Fairelm Ln.	Cheektowaga, NY 14227-1364
113.34-1-42		119	Fairelm	Ln.	1			Ragheb M. Salla	Hala M. Salla		119 Fairelm Ln.	Cheektowaga, NY 14227
113.34-1-41		121	Fairelm	Ln.	3			Timothy A. Petranchuk	Christine Petranchuk		121 Fairelm Ln.	Cheektowaga, NY 14227-1365
113.34-3-2		122	Fairelm	Ln.	1		Cracked /Tree	Daniel Olejniczak	& Elizabeth		122 Fairelm Ln.	Cheektowaga, NY 14227-1364
113.34-1-40		123	Fairelm	Ln.	2	1		Marian Kochel	Jadwiga G. Kochel		123 Fairelm Ln.	Cheektowaga, NY 14227-1365
113.34-3-1		124	Fairelm	Ln.	2		Cracked W/Manhole Cover	Robert E. Johnson	Cheryl A. Johnson		124 Fairelm Ln.	Cheektowaga, NY 14227-1364
113.34-1-39		125	Fairelm	Ln.	1			Michael E. Mccarthy			125 Fairelm Ln.	Cheektowaga, NY 14227-1365
113.34-1-37		129	Fairelm	Ln.	1		Lifted w/Manhole Cover	Kyle S. Tauscher			129 Fairelm Ln.	Cheektowaga, NY 14227-1365
113.50-7-4		15	Fairelm	Ln.	3			James F. Barciniak	Dolores Barciniak		15 Fairelm Ln.	Cheektowaga, NY 14227-1322
113.50-5-10		16	Fairelm	Ln.	3			Salvatore Fasciana			32 Fairoaks Ln.	Cheektowaga, NY 14227
113.50-7-5		17	Fairelm	Ln.	6	4		Carmen J. Verrastro & Gail			17 Fairelm Ln.	Cheektowaga, NY 14227-1322
113.50-5-9		18	Fairelm	Ln.	3			William A. Wodowski & W			45 Foxhunt Rd.	Lancaster, NY 14086-1132
113.50-7-6		21	Fairelm	Ln.	7			Frank A. Wrazen Jr. & W			30 Running Brook Dr.	Lancaster, NY 14086-3309
113.50-7-7		23	Fairelm	Ln.	3			Sophia Sousanidis	Angelika Welsh		23 Fairelm Ln.	Cheektowaga, NY 14227-1322
113.50-6-11		26	Fairelm	Ln.	4			Gerald J. Miller	Lois E. Miller		26 Fairelm Ln.	Cheektowaga, NY 14227-1356
113.50-7-10		29	Fairelm	Ln.	1			James P. Burzynski			29 Fairelm Ln.	Cheektowaga, NY 14227-1357
113.50-6-9		36	Fairelm	Ln.	1			Raymond Lewinski	Diane M. Lewinski		36 Fairelm Ln.	Cheektowaga, NY 14227-1356
113.50-7-14		37	Fairelm	Ln.	1			James E. Carpenter	Mary Ann Carpenter		37 Fairelm Ln.	Cheektowaga, NY 14227-1357
113.50-7-15		39	Fairelm	Ln.	1			Joseph Roman	Mary Roman		39 Fairelm Ln.	Cheektowaga, NY 14227-1357
113.50-7-16		41	Fairelm	Ln.	6	2		Craig E. Campbell & W			41 Fairelm Ln.	Cheektowaga, NY 14227-1357
113.50-7-17		43	Fairelm	Ln.	2			Irena Mychajliw	Jean Mychajliw		43 Fairelm Ln.	Cheektowaga, NY 14227-1357
113.50-6-8		44	Fairelm	Ln.	1	2		Camille A. Viverto & W			176 Meadowlawn Rd.	Cheektowaga, NY 14225-3633
113.50-6-7		46	Fairelm	Ln.	3		Dipped	Ronny J. Baden			46 Fairelm Ln.	Cheektowaga, NY 14227-1356
113.50-6-6		48	Fairelm	Ln.	2			Martin L. Pecoraro			5660 Kippen Dr.	E Amherst, NY 14051-1967
113.50-7-20		49	Fairelm	Ln.	1			David C. Hall			49 Fairelm Ln.	Cheektowaga, NY 14227
113.50-6-4		52	Fairelm	Ln.	2	2	Cracked w/Manhole Cover	Jason R. Pagano	Stefanie A. Leo		52 Fairelm Ln.	Cheektowaga, NY 14227
113.50-7-22		53	Fairelm	Ln.	2		Dipped	Luigi F. Monaco	Maria Monaco		53 Fairelm Ln.	Cheektowaga, NY 14227-1357
113.50-6-3		54	Fairelm	Ln.	1			Paul R. Delano Sr. & W			54 Fairelm Ln.	Cheektowaga, NY 14227-1356
113.50-6-2		56	Fairelm	Ln.	2			Anthony Notaro	Barbara L. Notaro		56 Fairelm Ln.	Cheektowaga, NY 14227-1356
113.50-7-24		57	Fairelm	Ln.	2	1		Geraldine A. Semanscin			57 Fairelm Ln.	Cheektowaga, NY 14227
113.50-6-1		58	Fairelm	Ln.	2		Lifted	Amy L. Krytus	Eric M. Godzich		58 Fairelm Ln.	Cheektowaga, NY 14227-1356
113.42-7-18		59	Fairelm	Ln.	3			Christopher M. Alessi			59 Fairelm Ln.	Cheektowaga,

Attachment: Sidewalk list June 2 2014-05292014220439 (RES-2014-351 : Order Replacement of Sidewalks)

113.42-6-24		60	Fairelm	Ln.	1	1		Natalie C. Blas	Caroline A. Sisson		60 Fairelm Ln.	Cheektowaga, NY 14227
113.42-7-17		61	Fairelm	Ln.	1			Rita Farber			61 Fairelm Ln.	Cheektowaga, NY 14227-1357
113.42-6-23		62	Fairelm	Ln.		2	Cracked	Brian K. Pietrzak			62 Fairelm Ln.	Cheektowaga, NY 14227
113.42-7-15		65	Fairelm	Ln.	1			Rose M. Herzog			65 Fairelm Ln.	Cheektowaga, NY 14227-1357
113.42-6-21		66	Fairelm	Ln.	1			Sherry L. Pruchnowski	& Timothy M.		66 Fairelm Ln.	Cheektowaga, NY 14227-1356
113.42-7-13		69	Fairelm	Ln.	1			Carl R. Mc Claney	Joyce Mc Claney		69 Fairelm Ln.	Cheektowaga, NY 14227-1357
113.42-6-19		70	Fairelm	Ln.	2			Norma S. Gaiser			70 Fairelm Ln.	Cheektowaga, NY 14227-1356
113.42-7-12		71	Fairelm	Ln.	1			Linda Jelowski			71 Fairelm Ln.	Cheektowaga, NY 14227-1357
113.42-7-11		73	Fairelm	Ln.	2	2		Rita Zaganiaczyk	Wayne Zaganiaczyk		73 Fairelm Ln.	Cheektowaga, NY 14227-1357
113.42-7-10		75	Fairelm	Ln.	4	4		Jerry J. Ciesielski	Dorothy R. Ciesielski		75 Fairelm Ln.	Cheektowaga, NY 14227-1357
113.42-7-9		77	Fairelm	Ln.	4		(1) Fairelm, (3) Bink	Nicolette Alfieri			77 Fairelm Ln.	Cheektowaga, NY 14227-1357
113.42-7-8		79	Fairelm	Ln.	1			Sharon T. Prime	Elaine M. Memmo		17 Sausalito Dr.	E Amherst, NY 14051
113.42-6-13		82	Fairelm	Ln.	1	1		John P. Paoletta & W			82 Fairelm Ln.	Cheektowaga, NY 14227-1354
113.42-6-12		84	Fairelm	Ln.	3			Joseph J. Florczak			84 Fairelm Ln.	Cheektowaga, NY 14227-1354
113.42-6-11		86	Fairelm	Ln.	4			Izabella Karmilowicz			86 Fairelm Ln.	Cheektowaga, NY 14227-1354
113.42-7-5		89	Fairelm	Ln.	5		Badly Lifted	Jonathan P. Malczewski	Erin P. Malczewski		89 Fairelm Ln.	Cheektowaga, NY 14227
113.50-7-1		9	Fairelm	Ln.			Sanitary Repair (about 4 blocks)	Robert J. Lewandowski	& Stephanie J.		9 Fairelm Ln.	Cheektowaga, NY 14227
113.42-7-4		91	Fairelm	Ln.	5			Barbara Hawk	Michael R. Hobart		91 Fairelm Ln.	Cheektowaga, NY 14227-1355
113.42-7-3		97	Fairelm	Ln.	4			Richard Wroblewski		c/o Sister Aileen Wroblewski	600 Doat St.	Buffalo, NY 14211
113.42-6-5		98	Fairelm	Ln.	1			Carmen M. Monaco	Jill A. Monaco		98 Fairelm Ln.	Cheektowaga, NY 14227-1337
113.34-3-12		145	Vern	Ln.	6		Fairelm Side	Eileen E. Gould			145 Vern Ln.	Cheektowaga, NY 14227-1347
113.42-6-3		150	Vern	Ln.	5		Fairelm Side	Gregory R. Hereth	Jamie B. Orłowski		150 Vern Ln.	Cheektowaga, NY 14227-1346
113.42-7-1		160	Vern	Ln.	7		(4) Fairelm, (3) Vern	Arthur S. Lonczak			160 Vern Ln.	Cheektowaga, NY 14227-1412
92.17-5-1		857	Dick	Rd.	9	3	Cracked	Anna G. Gala			221 Belmont Ave.	Winchester, KY 40391
92.13-4-12		869	Dick	Rd.	11	7	Cracked (2 Driveways)	Ronny Steltermann & 1			869 Dick Rd.	Cheektowaga, NY 14225-3533
92.13-4-14	W	22	Sobieski	Ave.	? (Blacktop)			Norman T. Kolb			22 W Sobieski Ave.	Cheektowaga, NY 14225-3531
92.17-5-2	W	25	Sobieski	Ave.	1		Lifted	Michael Belcer	Dolores Belcer		25 W Sobieski Ave.	Cheektowaga, NY 14225-3530
92.17-5-3	W	27	Sobieski	Ave.	7	3	Railroaded/Slanted	Dean Popielski			27 W Sobieski Ave.	Cheektowaga, NY 14225
92.13-4-16	W	30	Sobieski	Ave.	4			Eric P. Haak			30 W Sobieski Ave.	Cheektowaga, NY 14225
92.17-5-4	W	31	Sobieski	Ave.			Homeowner already has a concrete contractor & HWY will reimburse for (9) Marked	Robert M. Gardon & W			31 W Sobieski Ave.	Cheektowaga, NY 14225-3530
92.13-4-17	W	36	Sobieski	Ave.	8			Gerald E. Kruzicki			36 W Sobieski Ave.	Cheektowaga, NY 14225-3531
92.13-4-18	W	40	Sobieski	Ave.	3		Bad Lift/Tree	Lenis Benzant-Ozoria			40 W Sobieski Ave.	Cheektowaga, NY 14225
92.13-4-19	W	44	Sobieski	Ave.	3	2		Theresa Sobczak	David Sobczak		44 W Sobieski Ave.	Cheektowaga, NY 14225-3531
92.17-5-5	W	47	Sobieski	Ave.	3		Slanted/Cracked	Thomas P. Christ & W			47 W Sobieski Ave.	Cheektowaga, NY 14225-3530
92.17-5-6	W	53	Sobieski	Ave.	7	1	Cracked	Escosian D. Torres			53 W Sobieski Ave.	Cheektowaga, NY 14225-3530
92.13-4-21	W	56	Sobieski	Ave.	3		Lifted	Diane Liptak			124 Old Stone Ln.	Lancaster, NY 14086
92.13-4-22	W	58	Sobieski	Ave.	1		Cracked	Patrick M. Paluszynski	Kathleen Paluszynski		58 W Sobieski Ave.	Cheektowaga, NY 14225-3531
92.13-4-23	W	60	Sobieski	Ave.	2		Cracked	David Dascomb	Marian R. Dascomb		60 W Sobieski	Cheektowaga, NY 14225
92.17-5-8	W	65	Sobieski	Ave.	3	1	Very Long Blocks	Paul J. Matuszewski & W			65 W Sobieski Ave.	Cheektowaga, NY 14225-3530
92.17-5-9	W	69	Sobieski	Ave.	2		Slanted/Tree	Susan M. Gallio			69 W Sobieski Ave.	Cheektowaga, NY 14225
92.17-5-10	W	73	Sobieski	Ave.	2		Lifted/Tree	Juliana L. Blask	Diane N. Dana		73 W Sobieski Ave.	Cheektowaga, NY 14225-3530
92.17-5-11	W	75	Sobieski	Ave.	1		Tilted	Theresa Anne Pernick			75 W Sobieski Ave.	Cheektowaga,

92.13-4-24	W	76	Sobieski Ave.	1		Cracked	Michael S. Moran			76 W Sobieski Ave.	Cheektowaga, NY 14225-4384
92.17-5-12	W	81	Sobieski Ave.	3		Cracked	Leigh M. White	Michael A. White		24 Conner Dr.	West Seneca, NY 14224-4384
92.14-7-3		97	Surfside Pkwy.	1			Madonna J. Markle	Peter Markle		97 Surfside Pkwy.	Cheektowaga, NY 14225-3729
92.14-7-7		102	Satinwood Dr.	4	2		John Ferreri	Nancy Ferreri		102 Satinwood Dr.	Cheektowaga, NY 14225-3747
92.14-8-7		105	Satinwood Dr.	4			Gordon C. Luther Jr.	Elizabeth A. Fox		105 Satinwood Dr.	Cheektowaga, NY 14225-3746
92.14-7-6		106	Satinwood Dr.	1	1		Kathy E. Knauf			27 W Home Dr.	Bowmansville, NY 14026
92.14-8-6		109	Satinwood Dr.	5			John F. Lumadue	Grace M. Lumadue		109 Satinwood Dr.	Cheektowaga, NY 14225
92.14-7-5		112	Satinwood Dr.	4			Kevin Gaczewski			112 Satinwood Dr.	Cheektowaga, NY 14225-3747
92.14-8-5		113	Satinwood Dr.	4			Donald F. Guenther	Marybeth Guenther		113 Satinwood Dr.	Cheektowaga, NY 14225-3746
92.14-8-4		117	Satinwood Dr.	4			Sandra A. Szpila			117 Satinwood Dr.	Cheektowaga, NY 14225-3746
92.14-6-16		12	Satinwood Dr.	5			Stephen F. Dudek	Theresa Dudek		12 Satinwood Dr.	Cheektowaga, NY 14225-3714
92.14-8-3		121	Satinwood Dr.	2			Walter J. Miller Jr.	Cheryl A. Miller		121 Satinwood Dr.	Cheektowaga, NY 14225-3746
92.14-8-1		129	Satinwood Dr.	2		Cor. Surfside	Jerome J. Albrecht & ETAL			129 Satinwood Dr.	Cheektowaga, NY 14225-3746
92.14-8-30		13	Satinwood Dr.	3	1		James Chmielewski & W			13 Satinwood Dr.	Cheektowaga, NY 14225-3713
92.14-8-24		37	Satinwood Dr.	5		Tree Roots	John Zito	Christine Zito		37 Satinwood Dr.	Cheektowaga, NY 14225-3715
92.14-6-18		4	Satinwood Dr.	8			William P. Mccarthy			4 Satinwood Dr.	Cheektowaga, NY 14225-3714
92.14-8-23		41	Satinwood Dr.	4			Carolyn A. Converso			41 Satinwood Dr.	Cheektowaga, NY 14225-3715
92.14-7-19		42	Satinwood Dr.	8			Karen L. Cardarella			12645 138th Ln.	Largo, FL 33774-3716
92.14-8-22		45	Satinwood Dr.	2			Joseph L. Mendola			45 Satinwood Dr.	Cheektowaga, NY 14225-3715
92.14-8-32		5	Satinwood Dr.	6	1		Frank Pecoraro	Molly R. Pecoraro		5 Satinwood Dr.	Cheektowaga, NY 14225
92.14-8-20		53	Satinwood Dr.	2			Wayne A. Hickok	Deborah M. Hickok		53 Satinwood Dr.	Cheektowaga, NY 14225-3715
92.14-8-19		57	Satinwood Dr.		1		Lucille Drzyzga			57 Satinwood Dr.	Cheektowaga, NY 14225-3715
92.14-7-18		58	Satinwood Dr.	1			Mary M. Blenk	Jean M. Tocha		58 Satinwood Dr.	Cheektowaga, NY 14225-3716
92.14-8-18		61	Satinwood Dr.	3			Christina M. LaBarbera			61 Satinwood Dr.	Cheektowaga, NY 14225-3715
92.14-7-17		62	Satinwood Dr.	3			Robert C. Enstrom & W			62 Satinwood Dr.	Cheektowaga, NY 14225-3716
92.14-8-17		65	Satinwood Dr.	4		Tree Roots	Dennis L. Fields	Almarie Fields		65 Satinwood Dr.	Cheektowaga, NY 14225-3715
92.14-7-16		66	Satinwood Dr.	7	1		Beverly Czarniak			66 Satinwood Dr.	Cheektowaga, NY 14225-3716
92.14-8-16		69	Satinwood Dr.	5			Christopher M. Eashak			69 Satinwood Dr.	Cheektowaga, NY 14225
92.14-7-15		70	Satinwood Dr.	2			Jay J. Ciesielski	Jordan R. Ciesielski		70 Satinwood Dr.	Cheektowaga, NY 14225-3716
92.14-8-15		73	Satinwood Dr.	2			Dennis M. Hagen	Donna A. Hagen		73 Satinwood Dr.	Cheektowaga, NY 14225-3715
92.14-7-13		78	Satinwood Dr.	3	1		Raymond A. Seymour & W			78 Satinwood Dr.	Cheektowaga, NY 14225-3716
92.14-8-13		81	Satinwood Dr.	1			Richard C. Tobin			81 Satinwood Dr.	Cheektowaga, NY 14225-3715
92.14-8-12		85	Satinwood Dr.	2	2		Elizabeth A. Nasca			85 Satinwood Dr.	Cheektowaga, NY 14225-3715
92.14-8-31		9	Satinwood Dr.	3			John E. Petlock	Margaret Petlock		9 Satinwood Dr.	Cheektowaga, NY 14225-3713
92.14-7-10		90	Satinwood Dr.	1	1		Joan E. Sevdale	Elaine S. Handley		90 Satinwood Dr.	Cheektowaga, NY 14225-3716
92.14-8-9		97	Satinwood Dr.	1			Susanne H. Bubar			97 Satinwood Dr.	Cheektowaga, NY 14225-3715
91.09-4-1		3	Beale Ave.	2			Claudia A. Kolbe-Hawthorne			3 Beale Ave.	Cheektowaga, NY 14225-2008



Town of Cheektowaga

Regular Meeting

~ Minutes ~

3301 Broadway
Cheektowaga, NY 14227
<http://www.town.cheektowaga.ny.us>

Alice Magierski
716-686-3400

Monday, June 16, 2014

6:45 PM

Council Chambers

I. Call to Order

6:45 PM Meeting called to order on June 16, 2014 at Council Chambers, 3301 Broadway St, Cheektowaga, NY.

Attendee Name	Organization	Title	Status	Arrived
Mary Holtz	Town of Cheektowaga	Supervisor	Present	
James P. Rogowski	Town of Cheektowaga	Councilmember	Present	
Gerald Kaminski	Town of Cheektowaga	Councilmember	Present	
Angela M. Wozniak	Town of Cheektowaga	Councilmember	Present	
Diane Benczkowski	Town of Cheektowaga	Councilmember	Present	
Timothy J. Meyers	Town of Cheektowaga	Councilmember	Present	

2. Additional Attendees

Ellen Fischer, Executive Director - Youth Board
Carla A. Kosmerl, Director of Community Development
Brian Krause, Director of Finance and Administration
William Pugh, Town Engineer
Kevin Schenk, Town Attorney

II. Public Comment Period

III. Resolutions



1. RESOLUTION 2014-352

Transfer of Funds

Sponsored By: Councilmember Kaminski, Supervisor Holtz

BE IT RESOLVED, that the following transfer is hereby approved and made part hereof;

CDBG

FROM:	700.1013.0600	Housing Rehab.-Single Family	\$42,144.80
	700.1013.0600	Housing Rehab.-Single Family	1,870.00
TO:	700.1013.0752	Rehab Activity Delivery Costs	\$42,144.80
	700.1013.0706	Housing Counseling Services	1,870.00

RESULT:	ADOPTED [UNANIMOUS]
MOVER:	Gerald Kaminski, Councilmember
SECONDER:	Mary Holtz, Supervisor
AYES:	Holtz, Rogowski, Kaminski, Wozniak, Benczkowski, Meyers



2. RESOLUTION 2014-353

Warrant

Sponsored By: Councilmember Kaminski, Supervisor Holtz

BE IT RESOLVED, that the following Vouchers & Warrants submitted to the Town of Cheektowaga prior to June 16, 2014 are hereby approved and made part hereof;

GENERAL FUND	\$293,308.13
RISK RETENTION FUND	14,631.58
NYS HOME PROGRAM	0.00
DEBT	0.00
HUD HOUSING REHABILITATION FUND	29,029.00
SPECIAL DISTRICTS FUND	2,728,285.98
HIGHWAY FUND	57,425.96
CAPITAL FUND	125,438.06
TRUST & AGENCY FUND	22,689.48
HUD CDBG FUND	2,519.58
PART TOWN FUND	3,999.10
NYS AFFORDABLE HOUSING	0.00
	<hr/>
	\$3,277,326.87

RESULT:	ADOPTED [UNANIMOUS]
MOVER:	Gerald Kaminski, Councilmember
SECONDER:	Mary Holtz, Supervisor
AYES:	Holtz, Rogowski, Kaminski, Wozniak, Benczkowski, Meyers



3. RESOLUTION 2014-354

Amend Sidewalk Replacement Resolution to Delete Address

Sponsored By: Councilmember Kaminski, Supervisor Holtz

WHEREAS, by resolution dated June 2, 2014 (Resolution 2014-351), this Town Board directed certain property owners to repair the sidewalks in front of their homes or else the Town would repair said sidewalks and assess 60% of the costs thereof against the property, and

WHEREAS, 97 Satinwood Drive was mistakenly placed on the list attached to said resolution, NOW, THEREFORE, BE IT

RESOLVED, that the list attached to Resolution 2014-351 be and hereby revised by deleting therefrom the address of 97Satinwood Drive.

RESULT:	ADOPTED [UNANIMOUS]
MOVER:	Gerald Kaminski, Councilmember
SECONDER:	Mary Holtz, Supervisor
AYES:	Holtz, Rogowski, Kaminski, Wozniak, Benczkowski, Meyers



4. RESOLUTION 2014-355

Adopt Local Law No. 3 of 2014 - A Local Law to Amend the Landlord Licensing Law

Sponsored By: Supervisor Holtz, Councilmember Kaminski

WHEREAS, the rental of residential dwellings is a business, and

WHEREAS, on March 4, 2013, the Town Board adopted Local Law No. 1 of the Year 2013 entitled "A Local Law Relating to Landlord Licensing", and

WHEREAS, there is a need to amend this local law to also require the licensing of landlords who rent out one-family, two-family and three-family dwelling units (excluding only owner-occupied 1-, 2-, and 3-family dwellings), and

WHEREAS, an amendment to the Landlord Licensing Law has been drafted to accomplish this purpose, and

WHEREAS, in accordance with the provisions of the Town Law/Municipal Home Rule Law of the State of New York, a public hearing was held on the 2nd day of June, 2014 at 6:45 P.M. at a meeting of the Town Board at the Cheektowaga Town Hall, 3301 Broadway, Cheektowaga, New York; at which hearing all interested parties were given an opportunity to be heard as to whether Local Law Intro No. 2014-3 of the Year 2014, entitled "A Local Law to Amend the Landlord Licensing Law" should be enacted, and

WHEREAS, it is in the public interest to adopt said local law, NOW, THEREFORE, BE IT

RESOLVED, that Local Law No. 3 of the Year 2014, entitled "A Local Law to Amend the Landlord Licensing Law", which is attached hereto and made a part hereof, be and the same is hereby enacted, and BE IT FURTHER

RESOLVED, that Local Law No. 3 of the Year 2014 shall be effective immediately after filing with the Secretary of State, and BE IT FURTHER

RESOLVED, that the Town Clerk shall file one (1) certified copy of this local law in her office and one (1) certified copy with the Secretary of State.

Attachments:

Amendment re one or more family (DOC)

RESULT: **ADOPTED [UNANIMOUS]**
MOVER: Mary Holtz, Supervisor
SECONDER: Gerald Kaminski, Councilmember
AYES: Holtz, Rogowski, Kaminski, Wozniak, Benczkowski, Meyers



5. RESOLUTION 2014-356

Call for a Public Hearing to Amend the Zoning Law - Local Law Intro No. 2014-4

Sponsored By: Supervisor Holtz, Councilmember Benczkowski

WHEREAS, by resolution dated January 21, 1992, Local Law No. 1 of the Year 1992 of the Town of Cheektowaga, entitled "A Local Law Relating to Zoning" was adopted, and

WHEREAS, there is a need for the Police Department to be able to cite and prosecute residential property owners who store unlicensed vehicles on their property; and people who erect signs on public property or on utility poles or trees, and

WHEREAS, the Petitions Committee has recommended that the Zoning Law be amended to permit the Police Department to enforce these provisions of the Zoning Law, and

WHEREAS, a draft of such amendment has been prepared by the Town Attorney, NOW, THEREFORE, BE IT

RESOLVED, that a public hearing be held on the 7th day of July, 2014 at 6:45 P.M. at the Town Hall, 3301 Broadway, Cheektowaga, New York to consider the advisability of adopting "A Local Law to Amend the Zoning Law to Authorize the Police Department to Enforce Various Provisions Thereof", and BE IT FURTHER

RESOLVED, that the Town Clerk be and hereby is directed to publish the attached Notice of Hearing in the Cheektowaga Bee.

NOTICE OF PUBLIC HEARING

NOTICE IS HEREBY GIVEN that, pursuant to the Municipal Home Rule Law of the State of New York, a Public Hearing will be held before the Town Board of the Town of Cheektowaga on the 7th day of July, 2014 at 6:45 P.M. at the Town Hall, 3301 Broadway, Cheektowaga, New York to consider and discuss and, if need be, act upon the proposed enactment of Local Law Intro No. 2014-4 of the Year 2014, entitled "A Local Law to Amend the Zoning Law to Authorize the Police Department to Enforce Various Provisions Thereof". Following is a synopsis of the proposed Local Law Intro No. 2014-4:

Local Law Intro No. 2014-4

**A Local Law to Amend the Zoning Law to Authorize the
Police Department to Enforce Various Provisions Thereof**

Section 260-68 of the Town Code (Zoning Law), **Administrative and enforcement officer**, shall be amended to read as follows:

A. Unless otherwise provided, the provisions of this chapter shall be administered and enforced by the Supervising Code Enforcement Officer and Code Enforcement Officers of the Town of Cheektowaga. The Code Enforcement Office/Building Inspections Department shall keep a complete file of all applications, permits, orders, certificates, requirements and decisions affecting each and every application filed with the Town of Cheektowaga pursuant to this chapter.

B. The provisions of 260-28.J.(2), Section 260-50.D.(3) and Section 260-50.D.(8) shall also be enforced by the Police Department.

Dated: June 16, 2014

BY ORDER OF THE TOWN BOARD OF THE TOWN OF CHEEKTOWAGA, ERIE
COUNTY, NEW YORK.

ALICE MAGIERSKI, Town Clerk

RESULT:	ADOPTED [UNANIMOUS]
MOVER:	Mary Holtz, Supervisor
SECONDER:	Diane Benczkowski, Councilmember
AYES:	Holtz, Rogowski, Kaminski, Wozniak, Benczkowski, Meyers



6. RESOLUTION 2014-357

Call for a Public Hearing to Amend the Solid Waste Law - Local Law Intro No. 2014-5

Sponsored By: Supervisor Holtz, Councilmember Kaminski

WHEREAS, by Local Law No. 5 of the Year 1992, the Cheektowaga Town Board enacted a Solid Waste Law (now known as Chapter 206 of the Code of the Town of Cheektowaga), and

WHEREAS, the Town Solid Waste Law needs to be amended to permit the Police Department to enforce various provisions thereof, and

WHEREAS, the Petitions Committee has recommended that the Solid Waste Law be amended to authorize the Police Department to enforce various provisions thereof, including provisions relating to illegal dumping and scavenging, and

WHEREAS, Local Law Intro No. 2014-5 of the Year 2014 was drafted by the Town Attorney to so amend Chapter 206 of the Town Code, NOW, THEREFORE, BE IT

RESOLVED, that a public hearing be held on the 7th day of July, 2014, at 6:45 P.M. at the Town Hall, 3301 Broadway, Cheektowaga, New York for the purpose of considering the adoption of Local Law Intro No. 2014-5 of the Year 2014, entitled "A Local Law to Amend the Solid Waste Law of the Town of Cheektowaga", and BE IT FURTHER

RESOLVED, that the Town Clerk be and hereby is directed to publish the attached Notice of Hearing in the CHEEKTOWAGA BEE, the official Town newspaper.



NOTICE OF HEARING

NOTICE IS HEREBY GIVEN, that a public hearing will be held before the Town Board of the Town of Cheektowaga on the 7th day of July, 2014 at 6:45 P.M. at the Town Hall, 3301 Broadway, Cheektowaga, New York to consider and discuss and, if need be, act upon a proposed Local Law entitled "A Local Law to Amend the Solid Waste Law of the Town of Cheektowaga". A brief summary of this local law is as follows:

Local Law Intro No. 2014-5 of the Year 2014

A Local Law To Amend the

Solid Waste Law of the Town of Cheektowaga

Subsection E of Section 206-9, **Supervision; promulgation of rules and regulations**, of the Town Code ("Solid Waste"), shall be amended to add the following language thereto:

The Police Department officers are also authorized to enforce the provisions of this article, and shall be authorized to issue informational notices, warning notifications, violation notices and appearance tickets under this chapter.

BY ORDER OF THE TOWN BOARD OF THE TOWN OF CHEEKTOWAGA, ERIE COUNTY, NEW YORK.

ALICE MAGIERSKI, Town Clerk

Dated: June 16, 2014

RESULT:	ADOPTED [UNANIMOUS]
MOVER:	Mary Holtz, Supervisor
SECONDER:	Gerald Kaminski, Councilmember
AYES:	Holtz, Rogowski, Kaminski, Wozniak, Benczkowski, Meyers



7. RESOLUTION 2014-358

Notice to Bidders - Firing Range Shelter (Bid #2014-29)

Sponsored By: Councilmember Benczkowski, Councilmember Kaminski

WHEREAS, the preparation of plans and specifications for the Firing Range Shelter on Scott Place in the Town of Cheektowaga have been completed by the Project Engineering Consulting firm of Nussbaumer & Clarke, Inc. NOW, THEREFORE, BE IT

RESOLVED, that the Town Clerk be directed to publish a Notice to Bidders for the Firing Range Shelter (Bid 2014-29), said notice to be published in the CHEEKTOWAGA BEE, AND, BE IT FURTHER

RESOLVED, that sealed bids will be received on the 9th day of July, 2014 at 11:00 am at a public bid opening conducted by the Town Clerk in the Council Chambers in the Cheektowaga Town Hall.



NOTICE TO BIDDERS

NOTICE IS HEREBY GIVEN that sealed proposals will be received by the Town Board of the Town of Cheektowaga until 11:00 a.m., local time, on the 9th day of July, 2014. All bids will be publicly opened and read at 11:00 a.m. in the Town Hall, 3301 Broadway, Cheektowaga, New York 14227 for furnishing all tools, equipment, materials, and labor for the Firing Range Shelter and all related work, complete in place, tested and ready for use in accordance with the contract documents therefore, including plans, specifications, instructions to bidders, etc., prepared by Nussbaumer & Clarke, Inc., Consulting Engineers.

All proposals shall be submitted on the forms furnished herein and the entire volume, including any addenda, shall be submitted in a sealed envelope and addressed to the Town Clerk of the Town of Cheektowaga, 3301 Broadway, Cheektowaga, New York 14227, to the attention of Alice Magierski, Town Clerk, and marked "Firing Range Shelter" (Bid 2014-29).

The contractor's name, title of the proposal, and date and time of the opening shall be clearly marked on the outside of the envelope.

Each proposal shall be accompanied by a certified check or bid bond in the amount of five percent (5%) of the amount of the bid, and shall be in the form and subject to the conditions provided for in the Instructions to Bidders.

Copies of the Drawings and Specifications and Contract Documents may be purchased at the Town Clerk's Office, Town Hall, 3301 Broadway, Cheektowaga, New York 14227; upon payment of a \$50.00 check made payable to the Town of Cheektowaga, New York for each copy requested. Neither the Owner nor the Engineer will be responsible for full or partial sets of Contract Documents, including any Addenda, obtained from any other source.

Any bidder returning Drawings and Specifications in good condition within 10 days following the bid opening will be refunded the full amount of the deposit. Non-bidders will not be

refunded. Material suppliers and anyone returning the Plans and Specifications before the bid opening will be classified as non-bidders. Any bidders requesting more than one (1) set of Drawings and Specifications may purchase the excess, but it is understood that these are non-refundable.

BIDDERS ON THIS WORK WILL BE REQUIRED TO COMPLY WITH THE PRESIDENT'S EXECUTIVE ORDER NO. 11246. THE REQUIREMENTS FOR BIDDERS AND CONTRACTORS UNDER THIS ORDER WHICH CONCERN NON-DISCRIMINATION IN EMPLOYMENT ARE EXPLAINED IN THE SPECIFICATIONS.

A pre-bid meeting will be held at 10:00 a.m. on the 30th of June, 2014, commencing at the Town of Cheektowaga Firing Range, located at the end of Scott Place, Cheektowaga, NY. Attendance at the pre-bid meeting is recommended, but is not mandatory.

The right to reject any and all bids, negotiate changes with the low bidder, to waive any informalities in, or to make an award to other than the low bidder, should it be deemed to be in the best interest of the Owner and in accordance with law, are herewith reserved.

By Order of: TOWN OF CHEEKTOWAGA

Alice Magierski, Town Clerk

DATED: June 16, 2014

PUBLISHED: June 19, 2014

RESULT:	ADOPTED [UNANIMOUS]
MOVER:	Diane Benczkowski, Councilmember
SECONDER:	Gerald Kaminski, Councilmember
AYES:	Holtz, Rogowski, Kaminski, Wozniak, Benczkowski, Meyers



8. RESOLUTION 2014-359

Authorize Supervisor to Execute Agreement with Erie County Water Authority

Sponsored By: Supervisor Holtz, Councilmember Kaminski

WHEREAS, Duke Road is a Town highway maintained by the Town of Cheektowaga Highway Department, and

WHEREAS, the waterline along a portion of Duke Road is in disrepair and will be replaced in 2014 by the Erie County Water Authority, and

WHEREAS, the Erie County Water Authority has requested the Town of Cheektowaga to perform restoration work in this portion of the Duke Road right-of-way after the waterline has been replaced, and

WHEREAS, a municipal cooperation agreement between the Town of Cheektowaga and Erie County Water Authority has been drafted to accomplish this purpose, and

WHEREAS, the Town of Cheektowaga and Town of Cheektowaga Superintendent of Highways have agreed to the Town performing this restoration work, NOW, THEREFORE, BE IT

RESOLVED, that the Supervisor be and hereby is authorized and directed to execute the aforementioned agreement with the Erie County Water Authority.

RESULT:	ADOPTED [UNANIMOUS]
MOVER:	Mary Holtz, Supervisor
SECONDER:	Gerald Kaminski, Councilmember
AYES:	Holtz, Rogowski, Kaminski, Wozniak, Benczkowski, Meyers



9. RESOLUTION 2014-360

Accept Proposal of Nussbaumer & Clarke, Inc. for Improvements at the Roycroft Pump Station

Sponsored By: Councilmember Meyers, Supervisor Holtz

WHEREAS, the Roycroft Pump Station is in need of upgrades and improvements, being one of the oldest of the eleven (11) pump stations within the Town Consolidated Sewer District and which facility is an integral component of the Town's wastewater collection and conveyance infrastructure, AND

WHEREAS, the existing 25 h.p. and 40 h.p. vertical end suction pumps in the Roycroft Pump Station have provided over 65 years of service and are in need of replacement, AND

WHEREAS, there is a need to prepare an engineering report, detailed drawings and technical specifications for the installation of new pumps, motors and variable frequency drives, replacement of suction piping, valves, structural support components, and associated electrical, instrumentation and control modifications, NOW, THEREFORE, BE IT

RESOLVED, that the proposal of Nussbaumer & Clarke, Inc., dated May 23, 2014 as submitted to the Town Engineer for professional services for the preparation of an engineering evaluation and report, design plans and technical specifications and related bid documents for improvements at the Roycroft Pump Station, Tasks No. 1 and No. 2, is accepted and approved, AND, BE IT FURTHER

RESOLVED, that the Supervisor, on behalf of this Town Board, is hereby directed and authorized to execute the professional services proposal for Tasks No. 1 and No. 2 with Nussbaumer & Clarke, Inc. for the provision of said technical services, AND, BE IT FURTHER

RESOLVED, that the cost of said professional services in an amount not to exceed \$36,200.00 shall be chargeable to Account No. 255-8125-4581.

RESULT:	ADOPTED [UNANIMOUS]
MOVER:	Timothy J. Meyers, Councilmember
SECONDER:	Mary Holtz, Supervisor
AYES:	Holtz, Rogowski, Kaminski, Wozniak, Benczkowski, Meyers



10. RESOLUTION 2014-361

Approve Purchase of One New and Unused 2014 Caterpillar Backhoe Loader 420F-IT

Sponsored By: Councilmember Kaminski, Supervisor Holtz

WHEREAS, the Town Board authorized the purchase of One New and Unused 2013 Caterpillar backhoe loader 420F-IT from Milton-Cat, 4610 East Saile Drive, Batavia, New York 14020, as specified under the contract documents for the Township of Brighton in Monroe County at a regular board meeting on April 15, 2013, AND

WHEREAS, said Township of Brighton contract is renewable for up to a three (3) year period, AND

WHEREAS, the proposed purchase agreement with Milton Cat contains the required language required by section 103-b of the General Municipal Law and otherwise complies with the New York State Law, AND

WHEREAS, Milton Cat offers a one year trade in program for said equipment , AND

WHEREAS, said trade in program is based on the hours of use of equipment and any price increase in the Township of Brighton contract, AND

WHEREAS, the Highway Department has requested authorization to trade-in one 2013 Caterpillar backhoe loader 420F-IT for one new and unused 2014 Caterpillar backhoe loader 420F-IT as specified under the terms of Milton Cat's trade-in program and the Township of Brighton's contract, AND

WHEREAS, funds for said purchase have been budgeted and are available under account number 300-5130-2407, NOW THEREFORE BE IT

RESOLVED, that the Town Board hereby authorizes to trade-in one 2013 Caterpillar backhoe loader 420F-IT for one new and unused 2014 caterpillar backhoe loader 420F-IT in the amount of \$8,314.00 from:

Milton Cat
4610 East Saile Drive
Batavia, NY 14020

RESULT:	ADOPTED [UNANIMOUS]
MOVER:	Gerald Kaminski, Councilmember
SECONDER:	Mary Holtz, Supervisor
AYES:	Holtz, Rogowski, Kaminski, Wozniak, Benczkowski, Meyers



11. RESOLUTION 2014-362

Approve Cultural Group Funding for Various Cultural Groups

Sponsored By: Councilmember Wozniak, Councilmember Rogowski

WHEREAS, the Town, in its 2014 budget, allocated moneys to certain cultural and not-for-profit organizations which are involved in activities which benefit the Town, and

WHEREAS, agreement(s) between the Town and these cultural and not-for-profit organizations have been prepared and forwarded to such groups, and

WHEREAS, the organization(s) listed below have completed and returned signed agreement(s) and their accounting report(s) from the 2013 funding to the Town, NOW, THEREFORE, BE IT

RESOLVED that this Town Board hereby approves agreement(s) with the cultural and not-for-profit organization(s) listed below for the amount(s) listed, and BE IT FURTHER

RESOLVED that the Supervisor be and hereby is authorized and directed to execute agreement(s) with the following referenced cultural and not-for-profit organization(s) for the following respective amount(s):

<u>Cultural/Not-For-Profit Organization</u>	<u>Funding Approved</u>
Cheektowaga Cultural Society	\$3,150.00
Cheektowaga Art Guild	\$1,200.00

And BE IT FURTHER

RESOLVED that the aforementioned moneys shall be paid to the respective cultural/not-for-profit organization(s) out of the respective cultural group budget line item(s) in the 2014 Town budget, subject to audit and approval of a properly signed Town voucher.

RESULT:	ADOPTED [UNANIMOUS]
MOVER:	Angela M. Wozniak, Councilmember
SECONDER:	James P. Rogowski, Councilmember
AYES:	Holtz, Rogowski, Kaminski, Wozniak, Benczkowski, Meyers



12. RESOLUTION 2014-363

Standard Work Day and Reporting Resolution

Sponsored By: Supervisor Holtz, Councilmember Kaminski

WHEREAS, the Comptroller of New York State has adopted revised regulations for reporting days worked by elected and appointed officials to the New York State and Local Retirement System (NYSLRS). Regulation 315.4 more clearly defines the reporting process and adds requirements for both employers and elected and appointed officials. Among the changes are an expanded record of work activities, a more detailed resolution and specific time frames within which requirements must be completed. This regulation applies to new terms of office or appointments beginning on or after August 12, 2009, NOW, THEREFORE BE IT

RESOLVED, that the Town of Cheektowaga hereby establishes the following as standard work days for elected officials and will report the following days worked to the New York State and Local Employees' Retirement System based on the record of activities maintained and submitted by these officials to the Clerk of this body:

Title	Name	Standard work day (hrs/day)	Term begins/ends	Participates in Employer's Time keeping	Days per month
Elected Officials					
Councilman	Diane Benczkowski	6	1/1/2014-12/31/2017	No	20
Councilman	James Rogowski	6	1/1/2014-12/31/2017	No	20
Councilman	Tim Meyers	6	1/1/2014-12/31/2017	No	9.2

* Based on record of activities

RESULT:	ADOPTED [UNANIMOUS]
MOVER:	Mary Holtz, Supervisor
SECONDER:	Gerald Kaminski, Councilmember
AYES:	Holtz, Rogowski, Kaminski, Wozniak, Benczkowski, Meyers



13. RESOLUTION 2014-364

Order Replacement of Sidewalks

Sponsored By: Councilmember Kaminski, Supervisor Holtz

WHEREAS, Chapter 210 of the Code of the Town of Cheektowaga (Streets and Sidewalks) sets forth the specifications for the construction of sidewalks in the Town of Cheektowaga, and

WHEREAS, Section 200-a of the Town Law of the State of New York authorizes a town board to adopt a local law to apportion the expense of building, relaying and repairing sidewalks in towns between the town and property owners, and

WHEREAS, this Town Board, by Local Law No. 4 of the Year 1991 and Local Law No. 5 of the Year 2008 (amended by Local Law No. 3 of the Year 2013), adopted provisions to apportion the cost of relaying or repairing sidewalks in the Town of Cheektowaga between the Town and property owners, and

WHEREAS, the Town Superintendent of Highways has supplied this Town Board with the attached list of sidewalks in the Town which are in need of repair or replacement, NOW, THEREFORE, BE IT

ORDERED, that the owners of properties on the attached list be and hereby are directed to repair/replace the sidewalks abutting such properties on or before July 14, 2014, in accordance with the Town's Streets and Sidewalks Law, and BE IT FURTHER

ORDERED, that, should such property owners neglect to or choose to not repair/replace their sidewalks as so notified before July 14, 2014, the Town will cause such sidewalks to be repaired/replaced; will pay \$46.40-51.20 for each 5-foot linear block repaired/replaced; and will assess/charge the property owner the balance over a period of five (5) years on the County/Town tax bill, with interest at the rate of 6.00 % as authorized by State law; or, at the property owner's option, payment may be made in one lump sum before September 30, 2014, and BE IT FURTHER

ORDERED, that the Town Clerk be and hereby is directed to notify the owners of properties identified on the attached list of the adoption of this Order by sending the attached Notice via certified mail to each owner at his/her/their address as it appears on the Town Assessment Roll.

**NOTICE OF ADOPTION OF ORDER
OF THE TOWN BOARD OF THE TOWN OF CHEEKTOWAGA**

TAKE NOTICE THAT, pursuant to a resolution adopted by the Town Board of the Town of Cheektowaga on June 16, 2014,

YOU ARE HEREBY ORDERED to repair the sidewalk in front of your property.

Such work must be completed on or before **July 14, 2014.**

In the event you neglect or choose not to perform this work before the specified date, be advised that the Town of Cheektowaga shall cause such work to be done. The Town will audit and pay \$46.40-\$51.20 for each 5-foot linear block replaced; and will assess the remaining expense thereof (including interest at the rate of 6.00%) against your property in five (5) annual installments; this amount will be added to your town tax bills for the next five (5) years and shall become a lien on your property. In the alternative, you may pay your share of the cost directly to the Town provided you do so on or before September 30, 2014. You will be notified of the amount you owe for sidewalk repairs.

If the Town performs the work, it is estimated that your cost for sidewalk repair will be approximately \$69.60-\$76.80 per 5-foot linear block of sidewalk.

If you choose to perform the work yourself or have a contractor perform such work, be advised that you will be responsible for paying 100% of the cost of the sidewalk work **(the Town will not pay anything towards your cost).**

BY ORDER OF THE TOWN BOARD OF THE TOWN OF CHEEKTOWAGA, ERIE COUNTY, NEW YORK.

DATED: June 16, 2014

ALICE MAGIERSKI
Town Clerk

Attachments:

Sidewalk Replacement List - 6-16-14 Meeting (PDF)

RESULT:	ADOPTED [UNANIMOUS]
MOVER:	Gerald Kaminski, Councilmember
SECONDER:	Mary Holtz, Supervisor
AYES:	Holtz, Rogowski, Kaminski, Wozniak, Benczkowski, Meyers



14. RESOLUTION 2014-365

Authorize ECWA to Install Hydrant

Sponsored By: Councilmember Meyers, Supervisor Holtz

WHEREAS, the Erie County Water Authority (ECWA) is replacing the existing water main on portions of Shanley Street, Bismarck Street and Dingens Street under Contract CH-006 consisting of the installation of 3750 L.F. of 8" ductile iron pipe and appurtenances, AND

WHEREAS, existing hydrant spacing within the project limits does not conform to current ECWA specifications and one (1) additional hydrant is required to be installed on Colton Street to provide for proper fire protection, together with minor relocation of the five (5) existing hydrants providing spacing consistent with ECWA standards, AND

WHEREAS, by letter dated June 5, 2014, the Doyle Fire District #1 Board of Fire Commissioners have notified the Town Engineer of their support for the installation of the additional hydrant, NOW, THEREFORE, BE IT

RESOLVED, that the Erie County Water Authority is hereby authorized to install one (1) additional hydrant to supplement the five (5) hydrants being relocated as part of the water main replacement project and that the Town of Cheektowaga shall be responsible for the payment of annual hydrant rental charges to the ECWA for one (1) additional hydrant being installed under this project, which charges shall be funded by the respective hydrant district, AND, BE IT FURTHER

RESOLVED, that the Town Clerk is directed to forward a certified copy of this resolution to:

Mr. Russell J. Stoll, P.E.
 Erie County Water Authority
 3030 Union Road
 Cheektowaga, New York 14227

RESULT:	ADOPTED [UNANIMOUS]
MOVER:	Timothy J. Meyers, Councilmember
SECONDER:	Mary Holtz, Supervisor
AYES:	Holtz, Rogowski, Kaminski, Wozniak, Benczkowski, Meyers



15. RESOLUTION 2014-366

Cleveland Hill Usage of Town Park

Sponsored By: Councilmember Wozniak, Councilmember Rogowski

WHEREAS, The Cleveland Hill Union Free School District has requested permission to utilize a portion of Cheektowaga Town Park from August 18, 2014 to September 30, 2014 for practices and for its home cross-county track team meets, and

WHEREAS, the General Crew Chief of the Facilities Department has reviewed such request and has no objection to same, and

WHEREAS, the Cleveland Hill Union Free School District has provided the Town with the necessary insurance coverage for such track meets, and

WHEREAS, Cleveland Hill Union Free School District shall be responsible to utilize individuals to provide traffic control to monitor students crossing the roadways for their track meets and practices, and

WHEREAS, this Town Board, in the spirit of cooperation, wishes to approve this request, NOW, THEREFORE, BE IT

RESOLVED, that this Town Board hereby approve the use of Cheektowaga Town Park from August 18, 2014 to September 30, 2014 for the Cleveland Hill Cross Country Track team practices, and BE IT FURTHER

RESOLVED, that the Director of Athletics of the Cleveland Hill School shall coordinate with the General Crew Chief of the Facilities Department concerning these track meets.

RESULT:	ADOPTED [UNANIMOUS]
MOVER:	Angela M. Wozniak, Councilmember
SECONDER:	James P. Rogowski, Councilmember
AYES:	Holtz, Rogowski, Kaminski, Wozniak, Benczkowski, Meyers



16. RESOLUTION 2014-367

Unsafe-Unsecured Shed/34 Barone Circle

Sponsored By: Councilmember Benczkowski, Supervisor Holtz

WHEREAS, Town of Cheektowaga Law for the Administration and Enforcement of the Codes of New York State; and the Property Maintenance Code of New York State require that all vacant structures and premises shall be maintained in clean, safe, secure and sanitary conditions so as not to cause a blighting problem or adversely affect the public health or safety and all nuisances abated, AND

WHEREAS, the Town of Cheektowaga has received notification of an unsafe structure and premises located at 34 Barone Circle, Cheektowaga, New York SBL# 92.17-5-29 that is a danger to the safety of others, and records kept by the Assessors Office identify Robert De Young and Arlene De Young, 3991 County Road, 210 W, Jacksonville, FL 32259, as the owner AND

WHEREAS, an inspection of such premises was conducted at 34 Barone Circle, by the Housing and Neighborhood Preservation Office, AND

WHEREAS, such inspection found the premises to be deteriorated, vacant, a hazard, and a danger to the safety and well being of others, AND

WHEREAS, the Town of Cheektowaga Housing and Neighborhood Preservation Office properly notified the property owner in accordance with the Town of Cheektowaga Law for the Administration and Enforcement of the Codes of New York State, and the owner failed to take actions to safeguard the premises, AND

WHEREAS, these conditions require the Town of Cheektowaga Housing and Neighborhood Preservation Office to take immediate steps to safeguard the premises to protect the health and safety of others and abate all nuisances, NOW, THEREFORE BE IT

RESOLVED, that pursuant to Section 70-7A.(5) and Section 70-8 of the Town of Cheektowaga Law for the Administration and Enforcement of the Codes of New York State that the vacant structure premises be safeguarded and all nuisances abated; and all costs incurred be assessed against the property hereinbefore described.

RESULT:	ADOPTED [UNANIMOUS]
MOVER:	Diane Benczkowski, Councilmember
SECONDER:	Mary Holtz, Supervisor
AYES:	Holtz, Rogowski, Kaminski, Wozniak, Benczkowski, Meyers



17. RESOLUTION 2014-368

Youth & Recreation Termination

Sponsored By: Councilmember Wozniak, Councilmember Rogowski

BE IT RESOLVED that the individuals listed below be and herby are terminated in the Department of Youth & Recreational Services effective as indicated:

Elizabeth Johnston	Never worked	14227
--------------------	--------------	-------

RESULT:	ADOPTED [UNANIMOUS]
MOVER:	Angela M. Wozniak, Councilmember
SECONDER:	James P. Rogowski, Councilmember
AYES:	Holtz, Rogowski, Kaminski, Wozniak, Benczkowski, Meyers



18. RESOLUTION 2014-369

Youth & Recreation Transfers

Sponsored By: Councilmember Wozniak, Councilmember Rogowski

BE IT RESOLVED that the individuals listed below be and hereby transferred, as indicated, in the Department of Youth & Recreational Services, effective immediately:

Laborer - "Level IV Participant" - 7310.1816 to Laborer - "Level I Supervisor Trainee" -

7310.1816 - \$9.20 - Seasonal

Christopher Suchan

Zachary Uzar

Laborer - "Level II Supervisor Trainee" - 7310.1816 - to Laborer "Youth Leader Level I -

7310.1811 - \$9.65 - Seasonal

Keith Kwiatkowski

Recreation Attendant - 7140.1614 & 7140.1645 - \$8.75 - Regular Part-Time

Brandon Koszuta

Recreation Attendant - 7140.1630 - \$8.75 - Regular Part-Time

Jessica Arana

Gabrielle Padovani

RESULT:	ADOPTED [UNANIMOUS]
MOVER:	Angela M. Wozniak, Councilmember
SECONDER:	James P. Rogowski, Councilmember
AYES:	Holtz, Rogowski, Kaminski, Wozniak, Benczkowski, Meyers



19. RESOLUTION 2014-370

Youth & Recreation Hiring

Sponsored By: Councilmember Wozniak, Councilmember Rogowski

BE IT RESOLVED that the individuals listed below be and hereby are hired, as indicated, in the Department of Youth & Recreational Services, effective immediately:

Recreation Aide - 7140.1648 - \$8.00 - Part-time

Kristina DiBlasio	14225
Leah Hoffman	14227

Recreation Aide - 7140.1646 - \$8.00 - Part-time

Andrew Meyerhofer	14225
-------------------	-------

Laborer - "Bathhouse Attendant - Level I" - 7180.1901 - \$8.00 - Seasonal

Haley Graczyk	14225
Samantha Sprada	14206

Recreation Attendant - 7140.1646 - \$8.00 - Regular Part-time

Kayla Green	14225
-------------	-------

Recreation Attendant - 7310.1801 - \$8.15 - Seasonal

Nicole Putland	14225
Kelly Mayer	14225

Recreation Attendant - 7310.1814 - Teen Club - \$8.00 - Seasonal

Jonathan Burlett	14211
------------------	-------

Recreation Attendant - 7310.1801 - \$8.00 - Seasonal

Jordan Jones	14211
--------------	-------

Recreation Attendant - 7140.1648 - \$8.00 - Seasonal

Bailey Michalski	14227
------------------	-------

Cheektowaga Conservation Corps (CCC)

Seasonal

Laborer - "Level I Participant" - 7310.1816 - \$8.00 - Seasonal

Maurice Lee	14225
Matthew Hencinski	14227

Laborer - "Level II Participant" - 7310.1816 - \$8.15 - Seasonal

Timothy Baumgart	14225
Rocco Fumerelle	14227

BE IT FURTHER RESOLVED, the following employee information be amended as follows (adding omitted line number):

Laborer - "Bathhouse Attendant - Level II" - 7180.1901 - \$8.15 - Seasonal

Tyler Ditta	14211
Amanda Kraus	14225
Joshua MacTarnaghan	14043

Laborer - "Bathhouse Attendant - Level III" - 7180.1901 - \$8.25 - Seasonal

Nolan Calos	14227
Paul Ciaflone	14227
Elizabeth Johnston	14227
Zachery Russillo	14227
Hayley Wnuk	14043

Laborer - "Bathhouse Attendant - Level IV"- 7180.1901 - \$8.35 - Seasonal

Kelley Astyk	14227
Sara Kapanek	14206
Paul A. Nazzarett	14227

RESULT:	ADOPTED [UNANIMOUS]
MOVER:	Angela M. Wozniak, Councilmember
SECONDER:	James P. Rogowski, Councilmember
AYES:	Holtz, Rogowski, Kaminski, Wozniak, Benczkowski, Meyers



20. RESOLUTION 2014-371

Hiring/Termination of Part Time/Seasonal Employees

Sponsored By: Councilmember Kaminski, Supervisor Holtz

BE IT RESOLVED, that the following individuals be and hereby are hired as **SEASONAL EMPLOYEES**, not to exceed five (5) months in a calendar year, in the various departments listed and in compliance with Civil Service Laws and Regulations as well as the provisions of the Town's collective bargaining agreement between the Town of Cheektowaga and the Town of Cheektowaga Employees Association:

SANITATION DEPARTMENT Laborer \$9.25/hour
 Romaine D. Harris, Cheektowaga, New York effective 6/9/14
 Ny'Juan E. Rainey, Cheektowaga, New York effective 6/9/14
 Andrew P. Babcock, Cheektowaga, New York effective 6/16/14
 Gregory L. Merritt, Cheektowaga, New York effective 6/12/14

RECORDS MANAGEMENT Student Intern \$8.50/hour effective 6/23/14
 Michael F. Krause, Cheektowaga, New York

BE IT RESOLVED, that the following part-time employees be and hereby are terminated as listed:

POLICE DEPARTMENT
 Anthony M. Theriault

RESULT:	ADOPTED [UNANIMOUS]
MOVER:	Gerald Kaminski, Councilmember
SECONDER:	Mary Holtz, Supervisor
AYES:	Holtz, Rogowski, Kaminski, Wozniak, Benczkowski, Meyers



21. RESOLUTION 2014-372

Appointment of Park Maintenance Worker I (Laborer/Temporary) Facilities Departments (Parks Division)/Peter M. Kreavy, Jr.

Sponsored By: Councilmember Rogowski, Councilmember Kaminski

WHEREAS, a temporary vacancy exists in the title of Park Maintenance Worker I in the Facilities Department (Parks Division); AND

WHEREAS, notice of said vacancy has been posted in accordance with the provisions of the Town's collective bargaining agreement with the Town of Cheektowaga Employees Association; AND

WHEREAS, Peter M. Kreavy, Jr., currently a Maintenance Worker in the Facilities Department, bid on said position and meets the necessary qualifications for appointment; NOW, THEREFORE, BE IT

RESOLVED, that Peter M. Kreavy, Jr. of Cheektowaga, New York, be and hereby is appointed to the temporary position of Park Maintenance Worker I in the Facilities Department (Parks Division) in accordance with the terms and conditions of the Town's collective bargaining agreement with the Town of Cheektowaga Employees Association effective June 17, 2014.

RESULT:	ADOPTED [UNANIMOUS]
MOVER:	James P. Rogowski, Councilmember
SECONDER:	Gerald Kaminski, Councilmember
AYES:	Holtz, Rogowski, Kaminski, Wozniak, Benczkowski, Meyers

IV. Suspension of Rules

Motion by Councilmember Rogowski; Seconded by Councilmember Meyers to waive the rules to Include one (1) resolution: 2014-373. Motion carried.



1. RESOLUTION 2014-373

Authorize Supervisor to Sign Agreement with SJB Services, Inc.

Sponsored By: Councilmember Meyers, Supervisor Holtz

WHEREAS, by Town Board Resolution dated May 19, 2014, the contract for the construction of the Sewer Maintenance Building Addition and Renovations was awarded to S.M. Hayes, LLC, AND

WHEREAS, the New York State Department of State, Division of Code Enforcement and Administration, requires special inspections during the duration of construction to be provided by an independent firm engaged by the owner, said testing is to include, but not be limited to, excavation and backfilling, reinforced and prestressed concrete, high strength bolting, welding and masonry, AND

WHEREAS, the Engineering Department solicited and received proposals from two (2) professional testing agencies in order to meet the aforesaid Special Inspection Program requirements, NOW, THEREFORE, BE IT

RESOLVED, that the proposal from SJB Services, Inc., 5167 South Park Avenue, Hamburg, New York 14075 is hereby approved and accepted, AND, BE IT FURTHER

RESOLVED, that the Supervisor, on behalf of this Town Board, is hereby directed and authorized to sign said agreement with SJB Services, Inc. for the provision of professional services in the field of Special Inspections in an amount not to exceed \$5,000.00 which shall be chargeable to Account #500-1440-4225-5325.

RESULT:	ADOPTED [UNANIMOUS]
MOVER:	Timothy J. Meyers, Councilmember
SECONDER:	Mary Holtz, Supervisor
AYES:	Holtz, Rogowski, Kaminski, Wozniak, Benczkowski, Meyers

V. Communications

A. Departmental Communications

1. Minutes: Cheektowaga Planning Board - May 8, 2014
2. Minutes: Town Environmental Advisory Committee - May 28, 2014

B. General Communications

1. **NYS DOT - Notice of Completion: Asph Concrete Milling & Resurfacing on Rts. NY 354 & 962Q in the Towns of Alden, Cheektowaga, Elma, Lancaster, West Seneca and Village of Depew in Erie County**
2. **Notice of Claim: Ravi Alluri vs. Town of Cheektowaga**
3. **Notice of Claim: Leonard Maciejewski vs. Town of Cheektowaga**
4. **Notice of Claim: David Randle vs. Town of Cheektowaga**

VI. Comments

A. Supervisor's Comments

B. Councilmember's Comments

C. Public Comments

VII. Adjournment

Motion by Supervisor Holtz; Seconded by Councilmember Kaminski to adjourn the meeting after a moment of silence for Police Officer Donald Ritter.

Alice Magierski, Town Clerk

LOCAL LAW NO. 3 OF THE YEAR 2014

A LOCAL LAW TO AMEND THE LANDLORD LICENSING LAW

1. Section 194-1.A. of the Town Code shall be amended to read as follows:
 - A. The Town of Cheektowaga hereby finds and declares that the rental of non-owner-occupied dwelling units constitutes a business which impacts upon the public health safety and general welfare of the residents of the Town of Cheektowaga. Residential non-owner-occupied rental properties may become a haven for various criminal or disruptive activities that can cause disorder in our community and affect the quality of life of others in the Town of Cheektowaga.

2. Section 194-1.C. of the Town Code shall be amended to read as follows:
 - C. It is the purpose of this article to implement a registration requirement for the owners of residential non-owner-occupied rental properties in order to curb criminal activity and disorder of such non-owner-occupied rental properties in the Town of Cheektowaga.

3. Section 194-3.A. of the Town Code shall be amended by deleting there from the word “four” and replacing it with the word “one”.

4. Section 194-3.B. of the Town Code shall be amended to read as follows:
 - B. Exemptions. The provisions of this chapter shall not apply to hotels, motels; bed-and-breakfast establishments; rooming or boarding houses; hospitals; nursing homes; or other dwelling units which offer or provide medical or nursing services if such units are subject to state or federal licensing or regulations concerning the safety of the users, patients or tenants. This law shall not apply to any one-family, two-family, three-family or four-family dwellings where the owner of said dwelling resides in one of the dwelling units of said dwelling.

5. Section 194-3.C. of the Town Code shall be amended by deleting there from the words “four or more dwelling units” and replacing them with the words “dwelling units”

6. The third and fourth sentences of Section 194-4.A. of the Town Code shall be amended by deleting there from the words “calendar year” and replacing them with the words “activity year”.

7. Subsections (1), (2), (3) and (4) of Section 194-4.A. of the Town Code shall be amended by deleting there from the words “calendar year” and replacing them with the words “activity year”

8. A new subsection C shall be added to Section 194-4 of the Town Code, which shall read as follows:
 - C. For purposes of this law, “activity year” shall mean the period of time commencing on June 1 of any year and ending on May 31 of the subsequent year

print_key	loc_st_n br	loc_st_name	loc_m ail_st_ suff	Blocks 4 inch	Approach 6 inch	Comments	owner_name	Zowner_name	3owner_name	Attention To:	Address	City/State/Zip
102.06-1-7.1	10	Lorraine	Ln.	2			Linda J. Szlachetka	Valerie Lombardo & Etal			10 Lorraine Ln.	Chktg., NY 14225-4122
102.06-1-6	14	Lorraine	Ln.	5			Irene Szeliga	Geraldine Mieth			14 Lorraine Ln.	Chktg., NY 14225-4122
102.06-1-3	26	Lorraine	Ln.	3			Derrick W. Simpson	Hillary M. Simpson			26 Lorraine Ln.	Chktg., NY 14225-4164
102.06-1-17	12	Anna	Ct.		1		Alvin K. Smith				12 Anna Ct.	Chktg., NY 14225-4105
102.06-1-13	13	Anna	Ct.	3			Miles Walter				13 Anna Ct.	Chktg., NY 14225-4105
102.06-1-14	17	Anna	Ct.	2			James T. Gregoire	James A. Illy			17 Anna Ct.	Chktg., NY 14225
102.06-1-15	19	Anna	Ct.	3			Denise I. Merrill				19 Anna Ct.	Chktg., NY 14225-4105
102.06-1-19	4	Anna	Ct.	4			Tamara M. Renowden				4 Anna Ct.	Chktg., NY 14225-4105
102.06-1-11	5	Anna	Ct.	4			Amy R. Runfola	Michael Runfola			5 Anna Ct.	Chktg., NY 14225
102.06-1-18	8	Anna	Ct.	1	1		Andrzej Swacha	Lucyna Swacha			8 Anna Ct.	Chktg., NY 14225
102.06-1-12	9	Anna	Ct.	2	2		John M. Ptak	Mary T. Ptak			9 Anna Ct.	Chktg., NY 14225-4105
102.23-9-6	295	George Urban	Bldv.	7		(Eastland Side)	Erin M. Casillo				295 George Urban Blvd.	Chktg., NY 14225
102.23-2-9	296	George Urban	Bldv.	7	3	(1) May be part of handicap cor.	Christopher Mahn				296 George Urban Blvd.	Chktg., NY 14225
102.23-8-1	305	George Urban	Bldv.	2			Robert C. Napierala & W				305 George Urban Blvd.	Chktg., NY 14225-3130
102.06-1-2	393	George Urban	Bldv.	2	3	(Lorraine Side)	David P. Lombardo	Amy B. Lombardo			393 George Urban Blvd.	Chktg., NY 14225
102.06-1-20	403	George Urban	Bldv.	2		(Lorraine Side)	Nancy Hassey				403 George Urban Blvd.	Chktg., NY 14225
102.31-2-12	15	Eastland	Pkwy.	4			Nina M. McGee	Billy Ray McGee			15 Eastland Pky.	Chktg., NY 14225-4114
102.23-2-8	160	Eastland	Pkwy.	3			Kevin K. Palmer	Michele Palmer			160 Eastland Pkwy.	Chktg., NY 14225-3134
102.23-2-7	164	Eastland	Pkwy.	2		Amanda's New House	Gregory Goehle				164 Eastland Pky.	Chktg., NY 14225-3113
102.23-2-6	168	Eastland	Pkwy.	3	2		Thomas P. Sealander	Judy S. Sealander			168 Eastland Pky.	Chktg., NY 14225-3113
102.23-3-18	175	Eastland	Pkwy.	1	1		Carmela Syracuse				175 Eastland Pkwy.	Chktg., NY 14225-3112
102.23-2-5	176	Eastland	Pkwy.	1			Penny L. DeStefano				176 Eastland Pkwy.	Chktg., NY 14225-3113
102.23-2-3	182	Eastland	Pkwy.	2			Quenttiss L. Rhodes				182 Eastland Pky.	Chktg., NY 14225-3113
102.23-2-2	192	Eastland	Pkwy.	2		(Eastland Side)	Jennifer F. Lovelace				192 Eastland Pky.	Chktg., NY 14225-3113
91.79-4-16	195	Eastland	Pkwy.	2			Patricia Mellenger	Kim Marie Fecher			195 Eastland Pky.	Chktg., NY 14225-3112
91.79-4-15	199	Eastland	Pkwy.	3			David P. Clark & Michelle				199 Eastland Pky.	Chktg., NY 14225-3112
91.79-5-11	200	Eastland	Pkwy.	2			Julian M. Szeglowski				200 Eastland Pky.	Chktg., NY 14225-3133
91.79-5-10	216	Eastland	Pkwy.	1			Victor G. Cain	Lorrene C. Cain			216 Eastland Pky.	Chktg., NY 14225-3133
91.79-5-9	222	Eastland	Pkwy.	3			Jeffrey J. Baran				222 Eastland Pkwy.	Chktg., NY 14225
91.79-5-8	228	Eastland	Pkwy.	2			Amber Bajer	Howard Nola			228 Eastland Pky.	Chktg., NY 14225-3133
91.79-4-20	229	Eastland	Pkwy.	2			Donald R. Ziems & W				229 Eastland Pky.	Chktg., NY 14225-3134
102.31-2-11	23	Eastland	Pkwy.	1			Sprandel Holdings LLC	Amanda Neamon			74 Niagara St.	Buffalo, NY 14202
91.79-4-21	233	Eastland	Pkwy.	2	1		George Trietley & 1				233 Eastland Pkwy.	Chktg., NY 14225
91.79-5-5	240	Eastland	Pkwy.	1			Romayne Frink				240 Eastland Pkwy.	Chktg., NY 14225-3133
91.79-5-4	246	Eastland	Pkwy.	3	1	(Near E. Grand)	Sophia Rajca				246 Eastland Pky.	Chktg., NY 14225-3133
102.31-2-10	29	Eastland	Pkwy.	3			Dwane G. Franklin				29 Eastland Pkwy.	Chktg., NY 14225

Attachment: Sidewalk Replacement List - 6-16-14 Meeting (RES-2014-364 : Order Replacement of

print_key	loc_st_n br	loc_st_name	loc_m ail_st suff	Blocks 4 inch	Approach 6 inch	Comments	owner_name	2owner_name	3owner_name	Attention To:	Address	City/State/Zip
102.31-2-14	3	Eastland	Pkwy.	1		at Deadend	Irene M. Fruehauf	John Fruehauf			3 Eastland Pkwy.	Chktg., NY 14225
102.31-2-9	33	Eastland	Pkwy.	3			Justin H. Dalton	Casey Bossert			33 Eastland Pkwy.	Chktg., NY 14225
102.31-2-6	47	Eastland	Pkwy.	6			Dawn C. Zywicki				47 Eastland Pky.	Chktg., NY 14225-4116
102.31-2-2	67	Eastland	Pkwy.		2	Slanted	Jenny L. Jablonski				67 Eastland Pkwy.	Chktg., NY 14225-4152
102.31-1-18	70	Lindbergh	Ct.	5	5	(Eastland Side)	Joseph P. Mills	Marybeth R. Mills			43 Lindbergh Ct.	Chktg., NY 14225
102.31-4-17	71	Lindbergh	Ct.	4	2	(Eastland Side)	Jeffrey R. Wilde				71 Lindbergh Ct.	Chktg., NY 14225-4119
102.31-3-9	103	Southern	Pkwy.	2			Gary D. Sterlace & W				103 Southern Pkwy.	Chktg., NY 14225-4154
102.31-4-27	104	Southern	Pkwy.	2	2		Eleanore Petrillo				104 Southern Pkwy.	Chktg., NY 14225-4153
102.31-3-10	107	Southern	Pkwy.	3			Denise DeNisco				187 Woodridge Ave.	Chktg., NY 14225
102.31-3-11	111	Southern	Pkwy.	1			Ronald E. Klepfer	Carol A. Klepfer			111 Southern Pkwy.	Chktg., NY 14225-4154
102.31-4-25	112	Southern	Pkwy.	2			Alfred S. Mrugalski	Lorraine J. Mrugalski			112 Southern Pkwy.	Chktg., NY 14225-4153
102.31-4-23	122	Southern	Pkwy.	2			Hollie A. Hamann				122 Southern Pkwy.	Chktg., NY 14225
102.31-3-14	127	Southern	Pkwy.	2			Jessica L. Nabach				127 Southern Pkwy.	Chktg., NY 14225
102.31-4-22	128	Southern	Pkwy.	1			Kate E. Owens				128 Southern Pkwy.	Chktg., NY 14225-4153
102.31-3-15	131	Southern	Pkwy.	1			James P. Gallagher & W				131 Southern Pkwy.	Chktg., NY 14225-4154
102.31-4-21	132	Southern	Pkwy.	4	3		Thomas K. Hinshaw				132 Southern Pkwy.	Chktg., NY 14225-4153
102.31-4-20	136	Southern	Pkwy.	1			Andrew Stuart	Karen A. Stuart			136 Southern Pkwy.	Chktg., NY 14225-4153
102.31-3-17	139	Southern	Pkwy.	1			Denise D. Mongiolo				139 Southern Pkwy.	Chktg., NY 14225-4154
102.31-4-19	140	Southern	Pkwy.	3			Yvonne M. Bonner	Cheryl A. Dybalski			140 Southern Pkwy.	Chktg., NY 14225-4153
102.31-3-18	147	Southern	Pkwy.	1			Joel R. Sheridan				147 Southern Pkwy.	Chktg., NY 14225-4154
102.31-4-18	148	Southern	Pkwy.	2			Kelly L. Keller				148 Southern Pkwy.	Chktg., NY 14227
102.30-3-13	50	Southern	Pkwy.	1			Norma J. Kerber				50 Southern Pkwy.	Chktg., NY 14225-4132
102.30-4-3	51	Southern	Pkwy.	1			Mark D. Wasiewicz	Naomi Wasiewicz			51 Southern Pkwy.	Chktg., NY 14225-4131
102.30-3-12	54	Southern	Pkwy.	2			Angel L. Matias Sr.				54 Southern Pkwy.	Chktg., NY 14225-4132
102.30-4-4	55	Southern	Pkwy.	4	1	Block is smaller	Resident pays only 2 blocks	Brad A. Brechler			55 Southern Pkwy.	Chktg., NY 14225
102.31-4-34	70	Southern	Pkwy.	1			Timothy S. Wyant				72 Isabel Rd.	Chktg., NY 14225
102.31-3-3	73	Southern	Pkwy.	2			Peter L. Pike III	Brenda M. Pike			73 Southern Pkwy.	Chktg., NY 14225-4154
102.31-4-32	78	Southern	Pkwy.		2		Harry C. Lindemuth	Josie M. Lindemuth			39 Le Havre Dr.	Chktg., NY 14227-2411
102.31-3-5	81	Southern	Pkwy.	2		Manhole	Joseph J. Machnica				81 Southern Pkwy.	Chktg., NY 14225-4154
102.31-4-31	82	Southern	Pkwy.	2			Julie A. Pierce				82 Southern Pkwy.	Chktg., NY 14225
102.31-3-7	91	Southern	Pkwy.	1			Donald R. Frazier	Debra Frazier			91 Southern Pkwy.	Chktg., NY 14225-4154
102.31-4-29	92	Southern	Pkwy.	1			Kim L. Hacker				92 Southern Pkwy.	Chktg., NY 14225
102.31-4-28	98	Southern	Pkwy.	5			Andrew M. Bialek & W				98 Southern Pkwy.	Chktg., NY 14225-4153
91.79-5-12	115	Northern	Pkwy.	1		(Eastland Side)	Larry Muhammad Sr.	Karen Muhammad			115 Northern Pkwy.	Chktg., NY 14225
91.79-4-14	191	Northern	Pkwy.	3		(Eastland Side)	Daniel J. Polino	Robert C. Polino	Linda A. Polino		191 Northern Pkwy.	Chktg., NY 14225-3124
91.79-4-1	222	E. Grand	Blvd.	3		(Eastland Side)	Earle H. Spencer				222 E Grand Blvd.	Chktg., NY 14225-3137
92.17-7-15	10	Lydia	Ln.	9			Casey J. Treichler				10 Lydia Ln.	Chktg., NY 14225
92.18-10-44	102	Lydia	Ln.	2			James H. Sneck	Lucia Sneck			102 Lydia Ln.	Chktg., NY 14225

Attachment: Sidewalk Replacement List - 6-16-14 Meeting (RES-2014-364 : Order Replacement of

print_key	loc_st_n br	loc_st_name	loc_m ail_st suff	Blocks 4 inch	Approach 6 inch	Comments	owner_name	2owner_name	3owner_name	Attention To:	Address	City/State/Zip
92.18-10-42	110	Lydia	Ln.	1	2		William J. Langan & W				110 Lydia Ln.	Chktg., NY 14225-3635
92.18-10-41	114	Lydia	Ln.	1	2		Robert P. Marzec	Sharon A. Marzec			114 Lydia Ln.	Chktg., NY 14225
92.18-9-19	117	Lydia	Ln.	1			Stephen J. Imerese	Michael Imerese			117 Lydia Ln.	Chktg., NY 14225-3634
92.18-10-40	118	Lydia	Ln.	2			Dorothy Repetowski				118 Lydia Ln.	Chktg., NY 14225-3635
92.18-10-39	122	Lydia	Ln.	1			Helen Casper	Maryanne P. Casper			1109 Wilbert Rd.	Lakewood, OH 44107
92.18-9-21	125	Lydia	Ln.	4			David Ngoc Nguyen				125 Lydia Ln.	Chktg., NY 14225
92.18-10-38	126	Lydia	Ln.	2			Carl P. Sirface	Marilyn R. Sirface			126 Lydia Ln.	Chktg., NY 14225-3635
92.18-9-22	129	Lydia	Ln.	2			Jon J. Pirong	Yen H. Pirong			129 Lydia Ln.	Chktg., NY 14225-3634
92.18-9-23	133	Lydia	Ln.	5			Sandra M. Budzynski				133 Lydia Ln.	Chktg., NY 14225-3634
92.18-10-36	134	Lydia	Ln.	4			James M. Giglio	Tracy A. Giglio			134 Lydia Ln.	Chktg., NY 14225-3635
92.18-9-24	137	Lydia	Ln.	2	1		Alphonse Villano	Rosanne Jeziorowski			137 Lydia Ln.	Chktg., NY 14225-3634
92.18-10-35	138	Lydia	Ln.	3			Michael A. Suriani, Trustee	M. Suriani Revocable Trust			138 Lydia Ln.	Chktg., NY 14225-3635
92.17-7-14	14	Lydia	Ln.	3			Gail M. Panfil				14 Lydia Ln.	Chktg., NY 14225
92.18-9-25	141	Lydia	Ln.	2	2		Christopher Koenig	Diane M. Koenig			141 Lydia Ln.	Chktg., NY 14225-3634
92.18-10-34	142	Lydia	Ln.	5			Justin R. Gawronski				142 Lydia Ln.	Chktg., NY 14225-3635
92.18-9-26	145	Lydia	Ln.	3			Anthony L. Puccio	Cassandra Sellers	Anthony M. Puccio		145 Lydia Ln.	Chktg., NY 14225-3634
92.18-10-33	146	Lydia	Ln.	1			Richard F. Niezgodna & W				146 Lydia Ln.	Chktg., NY 14225-3635
92.18-9-27	149	Lydia	Ln.	2			Frank M. Puszt				149 Lydia Ln.	Chktg., NY 14225-3634
92.18-9-28	153	Lydia	Ln.	4			Brandon G. Frawley				153 Lydia Ln.	Chktg., NY 14225
92.18-10-31	154	Lydia	Ln.	5	2		Helen T. Labus				154 Lydia Ln.	Chktg., NY 14225-3635
92.18-10-30	158	Lydia	Ln.	5			Adeline M. Koscinski				8 Angela Ln.	Chktg., NY 14225-4408
92.18-9-30	161	Lydia	Ln.	2			Rosemarie Bickelman				161 Lydia Ln.	Chktg., NY 14225-3634
92.18-10-28	166	Lydia	Ln.	4			Jeffrey H. Suto	Theresa V. Suto			166 Lydia Ln.	Chktg., NY 14225-3635
92.18-6-69	174	Lydia	Ln.	2			Francis Klipfel	Wendy Reidy			174 Lydia Ln.	Chktg., NY 14225-5204
92.18-6-68	178	Lydia	Ln.	1			Dorothy T. Lachcik	Paul D. Lachcik			178 Lydia Ln.	Chktg., NY 14225-5204
92.18-7-1	179	Lydia	Ln.	1			Shirley P. Gorski				179 Lydia Ln.	Chktg., NY 14225-5203
92.17-7-13	18	Lydia	Ln.	3	2		Samuel T. Caruso				18 Lydia Ln.	Chktg., NY 14225-3604
92.18-6-67	182	Lydia	Ln.	3	2		Wade A. Sprague	& Cynthia A. Held			182 Lydia Ln.	Chktg., NY 14225-5204
92.18-7-2	183	Lydia	Ln.	1			Lucia Zeuli				102 Lydia Ln.	Chktg., NY 14225-5203
92.18-7-3	187	Lydia	Ln.	1			Francine Mackowiak	Maria Marchinda			977 Cleveland Dr.	Chktg., NY 14225
92.18-7-4	191	Lydia	Ln.	2			Dennis E. Satison	Arline F. Satison			191 Lydia Ln.	Chktg., NY 14225-5203
92.18-7-5	195	Lydia	Ln.	1			Andrew J. Solecki Sr.	& Deborah A.			195 Lydia Ln.	Chktg., NY 14225-5203
92.18-6-63	198	Lydia	Ln.	2			John J. Getz			Attn: Karen McGrady	3730 Walden Ave.	Lancaster, NY 14086
92.18-7-6	199	Lydia	Ln.	2			Zofia Kowalski				199 Lydia Ln.	Chktg., NY 14225-5203
92.18-7-7	203	Lydia	Ln.	1			Jeffrey Borycki	Stacy Coffta	Bradley Borycki		203 Lydia Ln.	Chktg., NY 14225-5237
92.18-6-60	210	Lydia	Ln.	1			Richard A. Brem	Rosemarie J. Brem			210 Lydia Ln.	Chktg., NY 14225-5236
92.18-7-9	211	Lydia	Ln.	2			John A. Majerski	Carolyn A. Majerski			211 Lydia Ln.	Chktg., NY 14225-5237
92.18-7-10	215	Lydia	Ln.	3			Jennifer R. Burns				215 Lydia Ln.	Chktg., NY 14225-5237
92.18-6-58	218	Lydia	Ln.	4			Clifford P. Phalen & W				218 Lydia Ln.	Chktg., NY 14225-5236
92.17-7-12	22	Lydia	Ln.	2	2		Caroline V. Kueker				22 Lydia Ln.	Chktg., NY 14225-3604
92.18-7-11	221	Lydia	Ln.	3			Gail Scalzi				221 Lydia Ln.	Chktg., NY 14225-5237
92.18-7-12	225	Lydia	Ln.	2	2		Sharon E. Monheim				231 Rolling Green Ln.	Elma, NY 14059-9245
92.18-6-56	226	Lydia	Ln.	2			Ahmed Alharbi				226 Lydia Ln.	Chktg., NY 14225
92.18-6-55	230	Lydia	Ln.	2			Raymond Szarpa Jr.	Geraldine J. Szarpa			230 Lydia Ln.	Chktg., NY 14225-5236
92.18-7-14	237	Lydia	Ln.	5			Annalisa D. Rote				237 Lydia Ln.	Chktg., NY 14225-5237
92.18-6-51	248	Lydia	Ln.	1			Samuel K. Impastato	Lorraine T. Impastato			248 Lydia Ln.	Chktg., NY 14225-5236

Attachment: Sidewalk Replacement List - 6-16-14 Meeting (RES-2014-364 : Order Replacement of

print_key	loc_st_n br	loc_st_name	loc_m ail_st suff	Blocks 4 inch	Approach 6 inch	Comments	owner_name	Zowner_name	Sowner_name	Attention To:	Address	City/State/Zip
92.18-7-16	249	Lydia	Ln.	3			Michael A. Hermanski	& Nadine Ann Verga			249 Lydia Ln.	Chktg., NY 14225-5237
92.18-7-17	253	Lydia	Ln.	4			Jacklynn Pilat	Jill Chudy			187 Gary Ln.	Chktg., NY 14227
92.18-6-50	254	Lydia	Ln.	1			Stephen Tomczak	Michael Tomczak			254 Lydia Ln.	Chktg., NY 14225-5236
92.18-6-49	258	Lydia	Ln.	2			Daniel Urshel	Susanne Urshel			258 Lydia Ln.	Chktg., NY 14225-5236
92.18-7-20	269	Lydia	Ln.	2			Donna Demblewski				269 Lydia Ln.	Chktg., NY 14225-5237
92.18-6-46	270	Lydia	Ln.	1			Lloyd M. Gray Jr.	Tina A. Gray			270 Lydia Ln.	Chktg., NY 14225-5236
92.18-7-21	273	Lydia	Ln.	1			Paul F. Goehle	Dorothy J. Goehle			273 Lydia Ln.	Chktg., NY 14225-5237
92.18-6-45	274	Lydia	Ln.	2			Stanley Augustyn	Mary Augustyn			274 Lydia Ln.	Chktg., NY 14225-5236
92.18-6-44	278	Lydia	Ln.	3			Mary Lou Scharf	Luann M. Scharf			278 Lydia Ln.	Chktg., NY 14225-5236
92.18-7-23	281	Lydia	Ln.	1			Janet Mazurek	Todd Mazurek			281 Lydia Ln.	Chktg., NY 14225-5237
92.18-7-24	285	Lydia	Ln.	1	1		Wayne L. Full				285 Lydia Ln.	Chktg., NY 14225-5237
92.18-7-26	293	Lydia	Ln.	1			Thomas Wiegert	Loraine Wiegert			293 Lydia Ln.	Chktg., NY 14225-5237
92.18-6-40	294	Lydia	Ln.	1			Sharon A. Mahony				294 Lydia Ln.	Chktg., NY 14225-5236
92.18-7-27	297	Lydia	Ln.	1			Frank J. Manfre	Angeline Manfre			297 Lydia Ln.	Chktg., NY 14225-5237
92.18-7-28	301	Lydia	Ln.	2			Alexander F. Grierson	Sui Mei Grierson			301 Lydia Ln.	Chktg., NY 14225-5232
92.18-6-38	302	Lydia	Ln.	1			Jennifer L. Olivieri				302 Lydia Ln.	Chktg., NY 14225
92.18-7-29	305	Lydia	Ln.	1			Arthur V. Decker	Mark Decker			305 Lydia Ln.	Chktg., NY 14225-5232
92.18-6-37	306	Lydia	Ln.	1			Antoinette E. Danzi				306 Lydia Ln.	Chktg., NY 14225-5233
92.18-7-30	309	Lydia	Ln.	2			Richard L. Everett & W				309 Lydia Ln.	Chktg., NY 14225-5232
92.19-1-21	324	Lydia	Ln.	2			Richard J. Nowak	Frances M. Nowak			324 Lydia Ln.	Depew, NY 14043-1215
92.19-4-1	327	Lydia	Ln.	5			Hedwig Bellomo	Elia Bellomo			327 Lydia Ln.	Depew, NY 14043-1220
92.19-4-2	333	Lydia	Ln.	4			Joann T. Ulatowski				333 Lydia Ln.	Depew, NY 14043-1220
92.19-2-23	334	Lydia	Ln.	5			Anthony J. Zito	Jennifer L. Lewandowski			334 Lydia Ln.	Depew, NY 14043-1221
92.19-2-22	338	Lydia	Ln.	4			Donald J. Bauer & Mary E.				338 Lydia Ln.	Depew, NY 14043-1221
92.18-10-57	50	Lydia	Ln.	5			Bradley N. Hilimon				50 Lydia Ln.	Chktg., NY 14225
92.18-9-3	51	Lydia	Ln.	1			Betty J. Granger	Faye E. Granger			51 Lydia Ln.	Chktg., NY 14225-3605
92.18-10-55	58	Lydia	Ln.	2			David C. Pacholski				58 Lydia Ln.	Chktg., NY 14225
92.18-9-6	63	Lydia	Ln.	1			Laura E. Chiarmonte				63 Lydia Ln.	Chktg., NY 14225
92.18-9-7	67	Lydia	Ln.		2		David Hashimi				67 Lydia Ln.	Chktg., NY 14225
92.18-10-52	70	Lydia	Ln.	2			Francis Wesolowski	Carol Wesolowski			70 Lydia Ln.	Chktg., NY 14225-3606
92.18-10-51	74	Lydia	Ln.	1			Theresa Magiera	Kenneth Magiera			74 Lydia Ln.	Chktg., NY 14225-3606
92.18-9-9	75	Lydia	Ln.	2			Robert Tighe Jr. & Dawn A.				75 Lydia Ln.	Chktg., NY 14225-3605
92.18-10-50	78	Lydia	Ln.	1			James J. Weindel	Eleanor A. Weindel			78 Lydia Ln.	Chktg., NY 14225-3606
92.18-9-10	79	Lydia	Ln.	1			Perry Oddi				79 Lydia Ln.	Chktg., NY 14225-3605
92.18-10-49	82	Lydia	Ln.	10	2		Elvera R. Neri				82 Lydia Ln.	Chktg., NY 14225-3606
92.18-10-48	86	Lydia	Ln.	4			Denise R. Jedynek				86 Lydia Ln.	Chktg., NY 14225-3606
92.18-9-12	87	Lydia	Ln.	4			Ronald J. Szretter				87 Lydia Ln.	Chktg., NY 14225-3605
92.18-10-47	90	Lydia	Ln.	3			Anna Schmitt				90 Lydia Ln.	Chktg., NY 14225-3606
92.18-10-46	94	Lydia	Ln.	2			Brian R. Meyer	Lori T. Meyer			94 Lydia Ln.	Chktg., NY 14225-3606
92.18-9-14	97	Lydia	Ln.	2	1		Maureen A. Schaefer				97 Lydia Ln.	Chktg., NY 14225-3605
92.17-8-1.1	715-735	Dick	Rd.	9	9		Joseph M. Larocca				10390 Main St., Apt. 6	Clarence, NY 14031-1648
92.17-7-16	755	Dick	Rd.	2			Randall Benderson 1993-1 Tr	7-Eleven, Inc., AV Tax# 35177			P.O. Box 711	Dallas, TX 75221-0711
92.17-8-5	54	Homeworth	Pkwy.	1			Richard L. Mayer & W				54 Homeworth Pkwy.	Chktg., NY 14225-3636
92.17-7-10	62	Homeworth	Pkwy.	4			Sandra Kawecki				62 Homeworth Pkwy.	Chktg., NY 14225
92.18-10-59	67	Homeworth	Pkwy.	3			Bhavani Associates, LLC				16 Silverbell Cir.	Orchard Park, NY 14127
92.18-9-1	59	Homeworth	Pkwy.	1			Justin R. Hopkins				59 Homeworth Pkwy.	Chktg., NY 14225

Attachment: Sidewalk Replacement List - 6-16-14 Meeting (RES-2014-364 : Order Replacement of

print_key	loc_st_n br	loc_st_name	loc_m ail_st_ suff	Blocks 4 inch	Approach 6 inch	Comments	owner_name	2owner_name	3owner_name	Attention To:	Address	City/State/Zip
92.19-3-1	103	Sable Palm	Dr.	3			Kathryn Russ				5 Sandy Ln.	Buffalo, NY 14227
92.18-6-35	108	Sable Palm	Dr.	1			Richard O. Weigel	Carole Weigel			108 Sable Palm Dr.	Chktg., NY 14225-5223
92.19-1-24	109	Sable Palm	Dr.	1			Gerald M. Howard & Andrea				109 Sable Palm Dr.	Chktg., NY 14225-5224
92.19-3-5	106	Lou Ann	Dr.	5			Clifford P. LiPira	Maryanne Boncore			106 Lou Ann Dr.	Depew, NY 14043-1234
92.19-4-3	104	Banko	Dr.	3			Raymond G. Geska	Sarah E. Geska			104 Banko Dr.	Depew, NY 14043-1243
125.08-2-51	103	Knollwood	Dr.	4	1		Ann Griffo	Joe Griffo			103 Knollwood Dr.	Chktg., NY 14227-2650
125.08-2-52	107	Knollwood	Dr.	4	1	Lifted	Robert A. Przepiora & W				107 Knollwood Dr.	Chktg., NY 14227-2650
125.08-2-53	111	Knollwood	Dr.	5			Peter Przybyl & W				111 Knollwood Dr.	Chktg., NY 14227-2650
125.07-2-41	16	Knollwood	Dr.	6			Carmella Sorrento				16 Knollwood Dr.	Chktg., NY 14227-2619
125.07-2-40	20	Knollwood	Dr.	6		Slanted /Shifted	Alan W. Schulz	Terry L. Schulz			20 Knollwood Dr.	Chktg., NY 14227
125.07-2-39	24	Knollwood	Dr.	4	2	Blacktop/S unken	Steven A. Brady	Justine M. Brady			24 Knollwood Dr.	Chktg., NY 14227-2619
125.07-2-38	28	Knollwood	Dr.	3			Thomas E. Messing	Angela M. Messing			28 Knollwood Dr.	Chktg., NY 14227-2619
125.07-2-37	32	Knollwood	Dr.	4	2		Thomas A. Torella & W				32 Knollwood Dr.	Chktg., NY 14227-2619
125.07-3-1	35	Knollwood	Dr.	3		Sanitary Cover	David C. Kossin Jr.				35 Knollwood Dr.	Chktg., NY 14227-2618
125.07-2-36	36	Knollwood	Dr.	4	2	Cracked	Danielle M. Stotz				36 Knollwood Dr.	Chktg., NY 14227-2619
125.07-3-2	39	Knollwood	Dr.	1			Jeffrey J. Kowalewski	Julie A. Kowalewski			39 Knollwood Dr.	Chktg., NY 14227-2618
125.07-2-35	40	Knollwood	Dr.	1		Cracked	Emil Sweeney & W				40 Knollwood Dr.	Chktg., NY 14227-2619
125.07-3-3	43	Knollwood	Dr.	3			David J. Majka & W				43 Knollwood Dr.	Chktg., NY 14227-2618
125.07-2-34	44	Knollwood	Dr.	3	1	Cracked	Thomas G. Weiner & W				44 Knollwood Dr.	Chktg., NY 14227-2619
125.07-3-4	47	Knollwood	Dr.	2	1		Joseph W. Inglut & Arlene				47 Knollwood Dr.	Chktg., NY 14227-2618
125.07-2-33	48	Knollwood	Dr.	6			Kevin E. Malicki	Janice M. Weiner			48 Knollwood Dr.	Chktg., NY 14227-2619
125.07-3-5	51	Knollwood	Dr.	4			Thomas Peiffer	Rosemary Peiffer			51 Knollwood Dr.	Chktg., NY 14227-2618
125.07-2-32	52	Knollwood	Dr.	4		Slanted	Blanche Strychalski	Sharon Sobus			52 Knollwood Dr.	Chktg., NY 14227-2619
125.07-3-6	55	Knollwood	Dr.	3	1		Joseph J. Lasota				55 Knollwood Dr.	Chktg., NY 14227-2618
125.07-2-30	60	Knollwood	Dr.	1		Cracked	John A. Obarka & W				60 Knollwood Dr.	Chktg., NY 14227-2619
125.07-3-8	63	Knollwood	Dr.	5		Vacant Home	Eric W. Bremer				850 Ostrander Rd.	E. Aurora, NY 14052-1200
125.07-2-29	64	Knollwood	Dr.	3			Ralph C. Collins				64 Knollwood Dr.	Chktg., NY 14227-2619
125.07-3-9	67	Knollwood	Dr.	6			Ronald R. Szprygada & W				67 Knollwood Dr.	Chktg., NY 14227-2618
125.07-2-28	68	Knollwood	Dr.	3			David J. Chmielewski	& Kay A.			68 Knollwood Dr.	Chktg., NY 14227-2619
125.07-3-10	71	Knollwood	Dr.	2			Kimberly S. Zeltman				71 Knollwood Dr.	Chktg., NY 14227-2618
125.07-2-27	72	Knollwood	Dr.	3			James E. Herb & W				72 Knollwood Dr.	Chktg., NY 14227-2619
125.07-3-11	75	Knollwood	Dr.	5	2	Blacktop Covered	Jessica M. Spoor				75 Knollwood Dr.	Chktg., NY 14227-2618
125.07-2-26	76	Knollwood	Dr.	4			James J. Zerkowski & W				76 Knollwood Dr.	Chktg., NY 14227-2619
125.07-3-12	79	Knollwood	Dr.	2		Blacktop/S unken	Lois Tobolski				79 Knollwood Dr.	Chktg., NY 14227-2618
125.07-2-43	8	Knollwood	Dr.	2			Michael J. Ganje & W				8 Knollwood Dr.	Chktg., NY 14227-2619
125.07-2-25	80	Knollwood	Dr.	5	1		Donald Schmid				80 Knollwood Dr.	Chktg., NY 14227-2619
125.07-3-13	83	Knollwood	Dr.	3		Sunken	Ronald D. Boyle				1941 Coral Heights Blvd., U	Oakland Park, FL 33308
125.07-3-16	95	Knollwood	Dr.	1			Raymond H. Full	Megan Full			95 Knollwood Dr.	Chktg., NY 14227-2618
125.07-3-17	99	Knollwood	Dr.	4			Mary F. Dumpert				99 Knollwood Dr.	Chktg., NY 14227-2618

Attachment: Sidewalk Replacement List - 6-16-14 Meeting (RES-2014-364 : Order Replacement of

print_key	loc_st_n br	loc_st_name	loc_m ail_st suff	Blocks 4 inch	Approach 6 inch	Comments	owner_name	2owner_name	3owner_name	Attention To:	Address	City/State/Zip
125.07-2-22	137	Castlewood	Dr.	4		(Knollwood Side)	Carol S. Eagen				137 Castlewood Dr.	Chktg., NY 14227-2616
125.07-4-15	103	Basswood	Dr.	1			Michael S. Maziarz	Joanne Maziarz			103 Basswood Dr.	Chktg., NY 14227-2656
125.07-3-26	104	Basswood	Dr.	1	2		Ryan S. McCaffery				104 Basswood Dr.	Chktg., NY 14227-2657
125.07-3-27	108	Basswood	Dr.		1		Walter P. Pukalo & W				108 Basswood Dr.	Chktg., NY 14227-2657
125.08-4-17	11	Basswood	Dr.	5			Louise Herdzik				11 Basswood Dr.	Chktg., NY 14227
125.07-3-28	112	Basswood	Dr.	6	1		Frank D. Ziccardi				112 Basswood Dr.	Chktg., NY 14227-2657
125.07-4-12	115	Basswood	Dr.	1			Todd A. Neupert				115 Basswood Dr.	Chktg., NY 14227-2656
125.07-3-29	116	Basswood	Dr.	1			Lawrence R. Backlas II	Katherine Backlas			116 Basswood Dr.	Chktg., NY 14227-2657
125.07-4-11	119	Basswood	Dr.	1	4		Daniel A. Hammer	Kelly M. Hammer			119 Basswood Dr.	Chktg., NY 14227-2656
125.08-3-22	12	Basswood	Dr.	6	2		Robert B. Panfil & W				12 Basswood Dr.	Chktg., NY 14227-2609
125.07-3-30	120	Basswood	Dr.	1			David L. Zelazskiewicz	Florence M. Zelazskiewicz			120 Basswood Dr.	Chktg., NY 14227-2657
125.07-4-10	123	Basswood	Dr.	3	2		Edward S. Stanek	Iris Stanek			123 Basswood Dr .	Chktg., NY 14227-2656
125.07-3-31	124	Basswood	Dr.	3			James Keller	Elizabeth Keller			124 Basswood Dr.	Chktg., NY 14227-2657
125.07-3-32	128	Basswood	Dr.	6			Richard G. Kuhn	Karen E. Kuhn			128 Basswood Dr.	Chktg., NY 14227-2657
125.07-4-8	131	Basswood	Dr.	2			William A. Steves				131 Basswood Dr.	Chktg., NY 14227-2656
125.07-3-33	132	Basswood	Dr.	4			Patrick J. Morrow & 1				132 Basswood Dr.	Chktg., NY 14227-2657
125.07-4-7	135	Basswood	Dr.	3	1		Michael Paulick	Sarah Paulick			135 Basswood Dr.	Chktg., NY 14227
125.07-3-34	136	Basswood	Dr.	3			Robin F. Schmitt	Judy A. Schmitt			5074 Transit Rd., Apt. 226	Depew, NY 14043-4472
125.07-4-6	139	Basswood	Dr.	3			Elizabeth J. Peters				139 Basswood Dr.	Chktg., NY 14227-2656
125.07-3-35	140	Basswood	Dr.	4			Edward R. Swiatek				140 Basswood Dr.	Chktg., NY 14227-2657
125.07-3-36	144	Basswood	Dr.	2			Kenneth Nawojski & W				144 Basswood Dr.	Chktg., NY 14227-2657
125.07-4-4	147	Basswood	Dr.		2		Leonard Maida	Antoinette Maida			147 Basswood Dr.	Chktg., NY 14227-2656
125.07-3-37	148	Basswood	Dr.	3			Donald E. Nowak	Patti Jo Nowak			148 Basswood Dr.	Chktg., NY 14227-2657
125.07-3-38	152	Basswood	Dr.	3			Ronald A. Wagner	Beverly A. Wagner			152 Basswood Dr.	Chktg., NY 14227-2657
125.07-3-39.1	156	Basswood	Dr.	3			Richard C. Borowski Jr.	Christine A. Borowski			156 Basswood Dr.	Chktg., NY 14227-2657
125.07-4-1	159	Basswood	Dr.	5			Sharon M. Rybak	Jeffrey D. Rybak			159 Basswood Dr.	Chktg., NY 14227-2656
125.08-3-23	16	Basswood	Dr.	6			Kayla S. Maxon	Patrick Maxon			16 Basswood Dr.	Chktg., NY 14227-2609
125.08-4-15	19	Basswood	Dr.	4			Sondra L. McBride				19 Basswood Dr.	Chktg., NY 14227-2608
125.08-3-24	20	Basswood	Dr.	3			James A. Braciszewski	& Barbara			20 Basswood Dr.	Chktg., NY 14227-2609
125.08-4-14	23	Basswood	Dr.	4	2		Peter Sobczynski & 1				23 Basswood Dr.	Chktg., NY 14227-2608
125.08-3-25	24	Basswood	Dr.	1	1		Timothy T. Kopp	Diane J. Kopp			24 Basswood Dr.	Chktg., NY 14227-2609
125.08-3-26	28	Basswood	Dr.	1			Lynne M. Sobkowiak	Courtney L. Sobkowiak	Testamentary Trust		101 Hillwood Dr.	Chktg., NY 14227
125.08-4-12	31	Basswood	Dr.	5	1		Carol Ann Baker				31 Basswood Dr.	Chktg., NY 14227-2608
125.08-3-27	32	Basswood	Dr.	5			Norman Long	Eleanor Long			32 Basswood Dr.	Chktg., NY 14227-2609
125.08-4-11	35	Basswood	Dr.	2			Milford E. Archibald	Bernadine Archibald			35 Basswood Dr.	Chktg., NY 14227-2608
125.08-3-28	36	Basswood	Dr.	7			Doris Baumet	Dorothy Baumet & Etal			36 Basswood Dr.	Chktg., NY 14227-2609
125.08-4-10	39	Basswood	Dr.	6			Cynthia Oleszkowski				39 Basswood Dr.	Chktg., NY 14227-2608
125.08-3-20	4	Basswood	Dr.	5			Jacqueline Tefft	Gary Tefft			4 Basswood Dr.	Chktg., NY 14227-2609
125.08-3-29	40	Basswood	Dr.	4			Ronald E. Fentner	Frances M. Fentner			40 Basswood Dr.	Chktg., NY 14227-2609
125.08-4-9	43	Basswood	Dr.	4	3		John E. Wojcik & W				43 Basswood Dr.	Chktg., NY 14227-2608
125.08-3-30	44	Basswood	Dr.	1			Mary Ann Marinaccio				44 Basswood Dr.	Chktg., NY 14227-2609
125.08-4-8	47	Basswood	Dr.	2	2		Richard Gonzalez & Patric				47 Basswood Dr.	Chktg., NY 14227-2608
125.08-3-31	48	Basswood	Dr.	3	2		Jeffrey P. Banaszak	Jennifer M. Banaszak			48 Basswood Dr.	Chktg., NY 14227-2609
125.08-4-7	51	Basswood	Dr.	3			Mary Marinaccio-Mann				51 Basswood Dr.	Chktg., NY 14227-2608
125.08-4-6	55	Basswood	Dr.	3			William H. Herman Jr.	Kerry A. Botz			55 Basswood Dr.	Chktg., NY 14227-2608

Attachment: Sidewalk Replacement List - 6-16-14 Meeting (RES-2014-364 : Order Replacement of

print_key	loc_st_n br	loc_st_name	loc_m ail_st_ suff	Blocks 4 inch	Approach 6 inch	Comments	owner_name	2owner_name	3owner_name	Attention To:	Address	City/State/Zip
125.08-3-33	56	Basswood	Dr.	2			Jennifer M. Masters				56 Basswood Dr.	Chktg., NY 14227-2609
125.08-4-5	59	Basswood	Dr.	7			S.B. Litz				59 Basswood Dr.	Chktg., NY 14227-2608
125.08-3-34	60	Basswood	Dr.	2			Kathleen Gawelo				60 Basswood Dr.	Chktg., NY 14227-2609
125.08-4-4	63	Basswood	Dr.	1	4		Ardith Bulmahn				63 Basswood Dr.	Chktg., NY 14227-2608
125.08-4-3	67	Basswood	Dr.	7	4		Christopher Klodzinski	Deanna Benzin			67 Basswood Dr.	Chktg., NY 14225
125.08-4-18	7	Basswood	Dr.	6			Timothy R. Hutt	Victoria Hutt			7 Basswood Dr.	Chktg., NY 14227-2608
125.08-4-2	71	Basswood	Dr.	4			Pat Mormina				71 Basswood Dr.	Chktg., NY 14227-2608
125.08-4-1	75	Basswood	Dr.	5			James F. Guerin & Nancy A.				75 Basswood Dr.	Chktg., NY 14227-2608
125.08-3-38	76	Basswood	Dr.	3			Joseph R. Distefano	Carol Distefano			76 Basswood Dr.	Chktg., NY 14227-2609
125.08-3-21	8	Basswood	Dr.	4			James L. Borczynski	Suzanne M. Borczynski			8 Basswood Dr.	Chktg., NY 14227-2609
125.07-4-20	83	Basswood	Dr.	1			Laurie A. Reczek				83 Basswood Dr.	Chktg., NY 14227-2610
125.07-4-19	87	Basswood	Dr.	2			Ronald D. Sprandel & Diane				87 Basswood Dr.	Chktg., NY 14227-2610
125.07-3-22	88	Basswood	Dr.	4			Robert D. Lipowicz & Donna				88 Basswood Dr.	Chktg., NY 14227-2611
125.07-4-18	91	Basswood	Dr.	3			Gerald A. Birke	Judith A. Birke			91 Basswood Dr.	Chktg., NY 14227-2610
125.07-3-23	92	Basswood	Dr.	5			Richard Fredericks	Sharon Fredericks			92 Basswood Dr.	Chktg., NY 14227-2611
125.07-3-24	96	Basswood	Dr.	3			Mark W. Bless & W				96 Basswood Dr.	Chktg., NY 14227-2611
125.07-4-16	99	Basswood	Dr.	5			Anthony Rogala & W				99 Basswood Dr.	Chktg., NY 14227-2610
102.30-5-1	2627	Harlem	Rd.	1			Sisters of Charity Hospital	Annemarie Andrzejewski	Administrator, CH Prop Mngmt.		291 North St.	Buffalo, NY 14201
102.30-2-10	2645	Harlem	Rd.	1	6		2645 Harlem LLC				38 Blackfriar Ct.	Getzville, NY 14068
102.31-3-1	15	Rosewood	Ter.	4			Tham T. Nguyen				15 Rosewood Ter.	Chktg., NY 14225
125.11-1-18	10	Brentwood	Dr.	2			John J. Dantonio Jr. & W				10 Brentwood Dr.	Chktg., NY 14227-3208
125.07-13-20	108	Brentwood	Dr.	1		Manhole	Leszek Oles	Marzena Oles			108 Brentwood Dr.	Chktg., NY 14227-3271
125.07-13-19	110	Brentwood	Dr.	1			Richard F. Lesinski Sr.	Mark R. Lesinski			165 S Union Rd.	Wmsvl. NY 14221-6510
125.07-12-40	115	Brentwood	Dr.	1			Edward A. Potoczniak	Louise E. Potoczniak			115 Brentwood Dr.	Chktg., NY 14227-3270
125.07-12-41	119	Brentwood	Dr.	1			Beverly L. Wollage				119 Brentwood Dr.	Chktg., NY 14227-3270
125.07-13-16	120	Brentwood	Dr.	1			Sandra Crocker				120 Brentwood Dr.	Chktg., NY 14227
125.07-13-15	124	Brentwood	Dr.	1			Joseph Marchewka	Patricia Marchewka			124 Brentwood Dr.	Chktg., NY 14227-3208
125.07-13-14	128	Brentwood	Dr.	1			Gregory T. Samer & W				128 Brentwood Dr.	Chktg., NY 14227-3271
125.07-13-12	136	Brentwood	Dr.	2			Michael V. Full & W				136 Brentwood Dr.	Chktg., NY 14227-3271
125.07-12-46	139	Brentwood	Dr.	5			Thomas S. Schrimmel & 1				139 Brentwood Dr.	Chktg., NY 14227-3270
125.07-12-48	147	Brentwood	Dr.	1			Alfred H. Ostrowski				147 Brentwood Dr.	Chktg., NY 14227-3270
125.07-13-9	148	Brentwood	Dr.		2		Kenneth Misnik & 1				148 Brentwood Dr.	Chktg., NY 14227-3271
125.07-13-8	152	Brentwood	Dr.	1			Goddard Family Trust	Stephen D. Goddard			152 Brentwood Dr.	Chktg., NY 14227-3271
125.07-13-7	156	Brentwood	Dr.	1			Daniel J. Kaczmarek & W				156 Brentwood Dr.	Chktg., NY 14227-3271
125.07-12-52	163	Brentwood	Dr.	1			David C. Carpenter & W				163 Brentwood Dr.	Chktg., NY 14227-3270
125.07-12-53	167	Brentwood	Dr.	2			Dennis E. Farrell	Frieda G. Farrell			167 Brentwood Dr.	Chktg., NY 14227-3270
125.11-5-5	35	Brentwood	Dr.	5			Christine B. Moch				35 Brentwood Dr.	Chktg., NY 14227-3207
125.11-1-13	38	Brentwood	Dr.	1			Chester F. Okonczak Jr.	Patricia A. Okonczak			38 Brentwood Dr.	Chktg., NY 14227-3208
125.11-5-4	39	Brentwood	Dr.	1			Michael J. Veto & W				39 Brentwood Dr.	Chktg., NY 14227-3207
125.11-5-1	51	Brentwood	Dr.	2			Anthony W. Anderson	Eric Warzel			51 Brentwood Dr.	Chktg., NY 14227-3207
125.11-2-6	55	Brentwood	Dr.	3			Julia A. Monti	Alfonso B. Monti Jr.			55 Brentwood Dr.	Chktg., NY 14227-3209
125.11-2-5	59	Brentwood	Dr.	1			Sandra L. Kohr	Frederick G. Kohr			59 Brentwood Dr.	Chktg., NY 14227-3209
125.11-2-2	60	Brentwood	Dr.	3			Joseph V. Baun	Marian Baun			60 Brentwood Dr.	Chktg., NY 14227-3210
125.07-12-28	67	Brentwood	Dr.	2			Ronald E. Wisniewski	Beverly B. Wisniewski			67 Brentwood Dr.	Chktg., NY 14227-3249
125.07-13-30	68	Brentwood	Dr.	1			Carlton A. Swetland	Patsy A. Swetland			68 Brentwood Dr.	Chktg., NY 14227-3248
125.07-12-29	71	Brentwood	Dr.		1		The Rudnick Family Trust	Walter J. Rudnick Jr.			71 Brentwood Dr.	Chktg., NY 14227-3249

print_key	loc_st_n br	loc_st_name	loc_m ail_st suff	Blocks 4 inch	Approach 6 inch	Comments	owner_name	2owner_name	3owner_name	Attention To:	Address	City/State/Zip
125.07-13-27	80	Brentwood	Dr.	2			Kenneth H. Swartz	Elkie E. Swartz			80 Brentwood Dr.	Chktg., NY 14227-3248
125.07-12-35	95	Brentwood	Dr.	1			Richard J. Kaminski				95 Brentwood Dr.	Chktg., NY 14227-3249
125.11-1-11	8	Dartwood	Dr.	4		2 on Dartwood	Irene R. Hulse				18 Buffum St.	Buffalo, NY 14210-2404
125.11-5-9	900	French	Rd.	4			Thomas Hurd & W				900 French Rd.	Chktg., NY 14227-3632
102.21-7-43	100	Parkedge	Dr.	2			Howard J. McCoy	Howard & Lillian McCoy Family Tru			100 Parkedge Dr.	Chktg., NY 14225-4028
102.21-7-42	104	Parkedge	Dr.	3			Suzanne M. Kubera				104 Parkedge Dr.	Chktg., NY 14225-4028
102.29-1-13	105	Parkedge	Dr.	1	2		Carol Richter				105 Parkedge Dr.	Chktg., NY 14225-4027
102.21-7-41	110	Parkedge	Dr.	2			Noel N. Adams	& Amril A. Deslandes			110 Parkedge Dr.	Chktg., NY 14225-4028
102.29-1-14	111	Parkedge	Dr.	7	1		Lena Nice				111 Parkedge Dr.	Chktg., NY 14225-4027
102.21-7-40	114	Parkedge	Dr.	1			Katherine M. Grauer				114 Parkedge Dr.	Chktg., NY 14225-4028
102.29-1-15	115	Parkedge	Dr.	7	1		Mary Anne Robinson-Battel				115 Parkedge Dr.	Chktg., NY 14225-4027
102.21-7-39	120	Parkedge	Dr.	3			Paul F. Mohalski				120 Parkedge Dr.	Chktg., NY 14225-4028
102.29-1-16	121	Parkedge	Dr.	3	1		Joan Miller	Kurt G. Miller			121 Parkedge Dr.	Chktg., NY 14225-4027
102.21-7-38	124	Parkedge	Dr.	3	1		Victor Cannarozzo Jr.				124 Parkedge Dr.	Chktg., NY 14225
102.29-1-17	125	Parkedge	Dr.	5			Denise Martin				125 Parkedge Dr.	Chktg., NY 14225-4027
101.36-5-2	13	Parkedge	Dr.	2			Tony Morrison	Ella Jean Morrison			13 Parkedge Dr.	Chktg., NY 14225
102.21-7-37	130	Parkedge	Dr.	3			Jane A. Chrzastowski				130 Parkedge Dr.	Chktg., NY 14225-4028
102.29-1-18	131	Parkedge	Dr.	3	2		Sandra A. Mcdougal				131 Parkedge Dr.	Chktg., NY 14225-4027
102.21-7-36	134	Parkedge	Dr.	3			David J. Martin Jr.				134 Parkedge Dr.	Chktg., NY 14225-4028
102.29-1-19	135	Parkedge	Dr.	2	1		Todd M. Countryman	Susan M. Countryman			135 Parkedge Dr.	Chktg., NY 14225-4027
102.29-1-20	139	Parkedge	Dr.	6			Dorothy E. Neubauer				139 Parkedge Dr.	Chktg., NY 14225-4027
102.21-7-34	140	Parkedge	Dr.	4	2		Kristine A. Murszewski				140 Parkedge Dr.	Chktg., NY 14225-4028
102.21-7-35	144	Parkedge	Dr.	1			Harriet J. Dobiesz				144 Parkedge Dr.	Chktg., NY 14225-4028
102.21-7-33	150	Parkedge	Dr.	4			Dennis Kindelan	Amanda Suriani			150 Parkedge Dr.	Chktg., NY 14225-4028
102.21-7-32	156	Parkedge	Dr.	10			Celia T. Lasek				156 Parkedge Dr.	Chktg., NY 14225-4028
101.36-5-3	17	Parkedge	Dr.	4			Kenneth W. Speaker	Patricia A. Speaker			17 Parkedge Dr.	Chktg., NY 14225-4007
101.36-5-4	23	Parkedge	Dr.	3			Annette Nash				23 Parkedge Dr.	Chktg., NY 14225-4007
101.28-6-10	24	Parkedge	Dr.	1			Ronald T. Siekierski				24 Parkedge Dr.	Chktg., NY 14225-4008
101.36-5-5	29	Parkedge	Dr.	1			Christine E. Richter				29 Parkedge Dr.	Chktg., NY 14225-4007
101.28-6-9	30	Parkedge	Dr.	1			Azhar A. Numan-Ali	Tricia A. Numan-Ali			30 Parkedge Dr.	Chktg., NY 14225-4008
101.36-5-7	39	Parkedge	Dr.	5			Maria T. Miller				39 Parkedge Dr.	Chktg., NY 14225
101.28-6-7	40	Parkedge	Dr.	4			Jerome H. Daniels				40 Parkedge Dr.	Chktg., NY 14225
102.29-1-1	43	Parkedge	Dr.	1	2		Timothy L. Schwind & W				43 Parkedge Dr.	Chktg., NY 14225-4007
102.21-7-54	44	Parkedge	Dr.	1			Kerry Mars				44 Parkedge Dr.	Chktg., NY 14225
102.29-1-2	49	Parkedge	Dr.	3			Kenneth P. May & Karen M.				49 Parkedge Dr.	Chktg., NY 14225-4007
102.21-7-52	56	Parkedge	Dr.		1		Dawn J. Sacilowski				56 Parkedge Dr.	Chktg., NY 14225-4008
102.29-1-4	59	Parkedge	Dr.	2			Raymond A. Dubard	Heather E. Dubard			59 Parkedge Dr.	Chktg., NY 14225-4007
102.21-7-51	60	Parkedge	Dr.	3			Nannette M. Burke	Timothy M. Burke			60 Parkedge Dr.	Chktg., NY 14225-4008
102.29-1-5	65	Parkedge	Dr.	4			Salvatore J. Giudice & W				65 Parkedge Dr.	Chktg., NY 14225-4007
102.21-7-50	66	Parkedge	Dr.	5			Robert J. Pollak Jr.	Elizabeth Pollak			66 Parkedge Dr.	Chktg., NY 14225-4008
102.29-1-6	69	Parkedge	Dr.	5			Joseph E. Szymanski				69 Parkedge Dr.	Chktg., NY 14225-4007
102.29-1-7	75	Parkedge	Dr.	4			Gary W. Cox	Michael R. Barnard			75 Parkedge Dr.	Chktg., NY 14225-4007
102.21-7-48	76	Parkedge	Dr.	4	1		Raymond Sadowski				76 Parkedge Dr.	Chktg., NY 14225-4008
102.29-1-8	79	Parkedge	Dr.	2			Jared S. Zerjav				79 Parkedge Dr.	Chktg., NY 14225-4007
102.21-7-47	80	Parkedge	Dr.	3			Mark J. Piatkowski	& Sharon A.			80 Parkedge Dr.	Chktg., NY 14225-4008

Attachment: Sidewalk Replacement List - 6-16-14 Meeting (RES-2014-364 : Order Replacement of

print_key	loc_st_n br	loc_st_name	loc_m ail_st suff	Blocks 4 inch	Approach 6 inch	Comments	owner_name	Zowner_name	Sowner_name	Attention To:	Address	City/State/Zip
102.29-1-9	83	Parkedge	Dr.	3			Alfred T. Wojciechowski & W				83 Parkedge Dr.	Chktg., NY 14225-4007
102.21-7-46	84	Parkedge	Dr.	2	1		Carol A. Roth				84 Parkedge Dr.	Chktg., NY 14225-4008
102.29-1-10	89	Parkedge	Dr.	1			Maria Gorniak				89 Parkedge Dr.	Chktg., NY 14225-4007
102.21-7-45	90	Parkedge	Dr.	3			Joan E. Goble				90 Parkedge Dr.	Chktg., NY 14225
102.21-7-44	94	Parkedge	Dr.	4			Kenneth Sable	Nancy Sable			94 Parkedge Dr.	Chktg., NY 14225-4008
102.29-1-12	99	Parkedge	Dr.	2			Ronald R. Maving	Joyce Maving			99 Parkedge Dr.	Chktg., NY 14225-4007
102.21-7-31	163	David	Ave.	2			Timothy Vernen				163 David Ave.	Chktg., NY 14225-4029
101.36-5-1	369	Pine Ridge	Rd.	12		2 Blocks on Pine Ridge	Arlene Helfrich				369 Pine Ridge Rd.	Chktg., NY 14225-3936
101.28-6-13	373	Pine Ridge	Rd.	8			Regina Hino Lawrence				373 Pine Ridge Rd.	Chktg., NY 14225-3934
125.07-3-21	16	Parwood	Dr.	6			Jenny Kmiotek				16 Parwood Dr.	Chktg., NY 14227
92.19-3-4 & 92.19-1-22	712230	Transmission	Line	4			Niagara Mohawk Power Corp				300 Erie Blvd. W	Syracuse, NY 13202-4201
92.19-1-23 & 92.19-3-3	712229	Transmission	Land	13			Niagara Mohawk Power Corp				300 Erie Blvd. W	Syracuse, NY 13202-4201
92.14-8-29	17	Satinwood	Dr.	1	1		David C. Coons	Christina Coons			17 Satinwood Dr.	Chktg., NY 14225-3713
92.14-8-10	93	Satinwood	Dr.	1		Was previously recorded at # 97	Alan R. Eichberg	Barbara J. Eichberg			93 Satinwood Dr.	Chktg., NY 14225-3715
113.47-3-8	104	Milsom	Ave.		1		Eleanor Kurkowski				104 Milsom Ave.	Chktg., NY 14227-1218
113.40-1-9	117	Milsom	Ave.	1			Edward A. Blach	Dolores T. Blach			117 Milsom Ave.	Chktg., NY 14227-1217
113.40-1-11	125	Milsom	Ave.	2			Edward A. Nowak	Elizabeth Nowak			125 Milsom Ave.	Chktg., NY 14227-1217
113.40-1-12	129	Milsom	Ave.	1			Michele L. DiPirro				129 Milsom Ave.	Chktg., NY 14227-1217
113.40-1-13	133	Milsom	Ave.	4			Daniel P. Panek & Emily				133 Milsom Ave.	Chktg., NY 14227-1217
113.55-6-4	16	Milsom	Ave.	8			Michael Astyk				16 Milsom Ave.	Chktg., NY 14227
113.48-8-10	35	Milsom	Ave.	6			Marjorie Bonnell				35 Milsom Ave.	Chktg., NY 14227
113.55-6-1	42	Milsom	Ave.	1			Matthew Nowinski Jr.				42 Milsom Ave.	Chktg., NY 14227-1216
113.47-4-7	48	Milsom	Ave.		1		James C. Kaczanowski				48 Milsom Ave.	Chktg., NY 14227-1216
113.47-4-6	54	Milsom	Ave.	3			James S. Weinfurtner	Shannon C. Weinfurtner			54 Milsom Ave.	Chktg., NY 14227-1216
113.48-8-15	63	Milsom	Ave.	1			Thomas J. Franclemont	Mary A. Franclemont			63 Milsom Ave.	Chktg., NY 14227-1215
113.47-4-4	64	Milsom	Ave.	2			Daniel Sabadasz				64 Milsom Ave.	Chktg., NY 14227-1216
113.47-4-3	68	Milsom	Ave.	1			Stephen C. Hedgepeth	& Felicia S.			68 Milsom Ave.	Chktg., NY 14227
113.48-8-18	75	Milsom	Ave.	4			Scott Shaw & Jennifer				75 Milsom Ave.	Chktg., NY 14227-1215
113.47-3-14	80	Milsom	Ave.	2			Brian M. Papero Jr.	Danielle M. Papero			80 Milsom Ave.	Chktg., NY 14227-3824
113.48-1-9	81	Milsom	Ave.	2			Francis Urban	Susan Urban			81 Milsom Ave.	Chktg., NY 14227-1217
113.56-8-10	16	Columbus	Ave.	7	1		Diocesan Counseling Cente	For Clergy & Religious			525 Washington St.	Buffalo, NY 14203-1711
113.48-1-3	102	Patricia	Ln.	4			Michael J. Augustyniak	& Janice E.			102 Patricia Ln.	Chktg., NY 14227-1222
113.48-2-14	103	Patricia	Ln.	5	1		Thomas A. Kostelny & W				103 Patricia Ln.	Chktg., NY 14227-1221
113.48-1-2	106	Patricia	Ln.	4	1		Marcin J. Cichon				106 Patricia Ln.	Chktg., NY 14227
113.48-1-1	110	Patricia	Ln.	1			Denner Astyk	Norah Astyk			110 Patricia Ln.	Chktg., NY 14227-1222
113.48-2-16	111	Patricia	Ln.	1			John F. Sieber	Helen M. Sieber			111 Patricia Ln.	Chktg., NY 14227-1221
113.40-1-7	114	Patricia	Ln.	2			Eleanor Koska	Jacquelyn A. Astyk			114 Patricia Ln.	Chktg., NY 14227-1222

Attachment: Sidewalk Replacement List - 6-16-14 Meeting (RES-2014-364 : Order Replacement of

print_key	loc_st_n br	loc_st_name	loc_m ail_st_ suff	Blocks 4 inch	Approach 6 inch	Comments	owner_name	2owner_name	3owner_name	Attention To:	Address	City/State/Zip
113.40-1-6	118	Patricia	Ln.	8	1		Michael P. Green	Rachel M. Wagner			118 Patricia Ln.	Chktg., NY 14227-1222
113.40-2-11	119	Patricia	Ln.	2			Gloria Sinicki	Arthur T. Sinicki			119 Patricia Ln.	Chktg., NY 14227-1221
113.40-1-5	122	Patricia	Ln.	3			Leonard Gembala	Joanne Gervan			122 Patricia Ln.	Chktg., NY 14227-1222
113.40-2-12	123	Patricia	Ln.	1	1		Helen Szwajda				123 Patricia Ln.	Chktg., NY 14227-1221
113.40-2-13	127	Patricia	Ln.	2			Loretta A. Benczkowski				127 Patricia Ln.	Chktg., NY 14227-1221
113.40-1-3	130	Patricia	Ln.	4			Robert R. Maciejewski	Florence Maciejewski			130 Patricia Ln.	Chktg., NY 14227-1222
113.40-2-14	131	Patricia	Ln.	1			Joseph J. Lacki	David Lacki			131 Patricia Ln.	Chktg., NY 14227-1221
113.40-2-15	135	Patricia	Ln.	2			Rose M. Kasprowicz	Susan R. Kasprowicz			135 Patricia Ln.	Chktg., NY 14227-1221
113.40-1-1	138	Patricia	Ln.	8			Jerry L. Corp II				138 Patricia Ln.	Chktg., NY 14227
113.48-7-10	41	Patricia	Ln.	1		Cracked	Renata Ayerst				41 Patricia Ln.	Chktg., NY 14227-1219
113.48-8-9	42	Patricia	Ln.	1		Blktop	Andrew J. Skrzypczyk				45 Thomas Dr.	West Seneca, NY 14224
113.48-7-11	45	Patricia	Ln.	1			Cipressi Borthers Inc.				50 Strasmer Rd.	Depew, NY 14043
113.48-8-7	50	Patricia	Ln.	2			Kyle P. Martin				50 Patricia Ln.	Chktg., NY 14227
113.48-7-13	53	Patricia	Ln.		3	Cracked	Daniel P. Slowinski				8 Marie Ave.	Chktg., NY 14227
113.48-8-6	54	Patricia	Ln.	1			David B. Ayerst				54 Patricia Ln.	Chktg., NY 14227
113.48-7-14	57	Patricia	Ln.	2			Jonathan S. Draves				57 Patricia Ln.	Chktg., NY 14227
113.48-8-5	58	Patricia	Ln.	1			Thomas Staebell				4171 Heather Dr.	Williamsville, NY 14221
113.48-8-4	62	Patricia	Ln.	2	1	Cracked	Anthony M. Frank & W				62 Patricia Ln.	Chktg., NY 14227-1220
113.48-7-16	65	Patricia	Ln.	1			Paula A. Judy				65 Patricia Ln.	Chktg., NY 14227-1219
113.48-8-3	66	Patricia	Ln.	1	1	Cracked	Eric J. Prim				66 Patricia Ln.	Chktg., NY 14227
113.48-7-17	69	Patricia	Ln.	2			Rebecca L. McGrath				8831 Chestnut Ridge Rd.	Gasport, NY 14067-9375
113.48-8-2	70	Patricia	Ln.	3			Michael Ragyina				143 Briarcliff Rd.	Chktg., NY 14225
113.48-7-18	73	Patricia	Ln.	2	1		Patrick J. Davis				73 Patricia Ln.	Chktg., NY 14227
113.48-8-1	74	Patricia	Ln.	2			Karen Vitale-Smith	Brett Vitale	Danielle Vitale-Minter		74 Patricia Ln.	Chktg., NY 14227
113.48-1-8	82	Patricia	Ln.	3			David N. Raczyk				82 Patricia Ln.	Chktg., NY 14227-1222
113.48-2-9	83	Patricia	Ln.	6	2		Genevieve Fronczak				83 Patricia Ln.	Chktg., NY 14227-1221
113.48-1-7	86	Patricia	Ln.	3			Joseph R. Knospe				86 Patricia Ln.	Chktg., NY 14227-1222
113.48-2-10	87	Patricia	Ln.	4			Mohammad I. Bata				87 Patricia Ln.	Chktg., NY 14227-1221
113.48-1-6	90	Patricia	Ln.	4	1		Kevin P. Sager & 1				90 Patricia Ln.	Chktg., NY 14227-1222
113.48-2-11	91	Patricia	Ln.	1			Victor J. Styn	& Catherine M. Myszka			91 Patricia Ln.	Chktg., NY 14227-1221
113.48-1-4	98	Patricia	Ln.	6			David P. McNamara				98 Patricia Ln.	Chktg., NY 14227
113.48-2-13	99	Patricia	Ln.	2			Robert D. Jendrasik	Doreen A. Jendrasik			99 Patricia Ln.	Chktg., NY 14227-1221

Attachment: Sidewalk Replacement List - 6-16-14 Meeting (RES-2014-364 : Order Replacement of



Town of Cheektowaga

Work Session

~ Minutes ~

3301 Broadway
Cheektowaga, NY 14227
<http://www.town.cheektowaga.ny.us>

Alice Magierski
716-686-3400

Tuesday, July 1, 2014

6:00 PM

Council Office

I. Call to Order

6:00 PM Meeting called to order on July 1, 2014 at Council Office, Conference Room, Cheektowaga, NY.

Attendee Name	Organization	Title	Status	Arrived
Mary Holtz	Town of Cheektowaga	Supervisor	Present	
James P. Rogowski	Town of Cheektowaga	Councilmember	Present	
Gerald Kaminski	Town of Cheektowaga	Councilmember	Present	
Angela M. Wozniak	Town of Cheektowaga	Councilmember	Present	
Diane Benczkowski	Town of Cheektowaga	Councilmember	Present	
Timothy J. Meyers	Town of Cheektowaga	Councilmember	Present	

2. Additional Attendees

Brian Krause, Director of Finance and Administration

Kevin Schenk, Town Attorney

II. Public Portion

III. Resolutions



1. RESOLUTION 2014-374

Renewal of Excess Liability Insurance

Sponsored By: Supervisor Holtz, Councilmember Kaminski

WHEREAS, the Town's Excess Liability Insurance Coverage expires on July 1, 2014; and

WHEREAS, Holfoth Risk Management, the Town's insurance consultant, solicited proposals from brokers for the renewal of the Town's Excess Liability Insurance Coverage; and

WHEREAS, after review of the proposals received, Holfoth Risk Management recommends that the Town of Cheektowaga accept the proposal of Starr Indemnity & Liability Company (through Lawley Service., Inc.) for \$10,000,000 excess liability insurance coverage (including terrorism) (with \$1,000,000 retention/deductible); and

WHEREAS, this Town Board wishes to award the above referenced Town's Excess Liability Insurance to Starr Indemnity & Liability Company; NOW, THEREFORE, BE IT

RESOLVED, that this Town Board hereby awards the Town's Excess Liability Insurance as stated above to Starr Indemnity & Liability Company (through Lawley Service, Inc.) for the period from July 1, 2014 to July 1, 2015 for a premium of \$202,981.00; and BE IT FURTHER

RESOLVED, that payment for said insurance premium shall be appropriated from budget line item number 101.1710.4101; and BE IT FURTHER

RESOLVED, that the Supervisor be and hereby is authorized and directed to execute any and all documents to effectuate this excess liability insurance coverage.

RESULT:	ADOPTED [UNANIMOUS]
MOVER:	Mary Holtz, Supervisor
SECONDER:	Gerald Kaminski, Councilmember
AYES:	Holtz, Rogowski, Kaminski, Wozniak, Benczkowski, Meyers



Town of Cheektowaga

Regular Meeting

~ Minutes ~

3301 Broadway
Cheektowaga, NY 14227
<http://www.town.cheektowaga.ny.us>

Alice Magierski
716-686-3400

Monday, July 7, 2014

6:45 PM

Council Chambers

I. Call to Order

6:45 PM Meeting called to order on July 7, 2014 at Council Chambers, 3301 Broadway St, Cheektowaga, NY.

Attendee Name	Organization	Title	Status	Arrived
Mary Holtz	Town of Cheektowaga	Supervisor	Present	
James P. Rogowski	Town of Cheektowaga	Councilmember	Present	
Gerald Kaminski	Town of Cheektowaga	Councilmember	Present	
Angela M. Wozniak	Town of Cheektowaga	Councilmember	Present	
Diane Benczkowski	Town of Cheektowaga	Councilmember	Present	
Timothy J. Meyers	Town of Cheektowaga	Councilmember	Present	

2. Additional Attendees

Thomas Adamczak, Supervising Building and Plumbing Inspector
Michael Hockwater, Detective Cheektowaga Police
Paul Hockwater, Senior Public Safety Dispatcher
Carla A. Kosmerl, Director of Community Development
Brian Krause, Director of Finance and Administration
William Pugh, Town Engineer
Kevin Schenk, Town Attorney
David Zack, Chief of Police

II. Presentation

Cheektowaga Police Detective Michael Hockwater recognized for achievements as a Task Force Officer by Special Agent in Charge Brian Boetig, of the FBI Buffalo Office

III. Public Hearings

1. Amend the Zoning Law - Local Law Intro No. 2014-4

COMMENTS - Current Meeting:

This being the time and place advertised for a Public Hearing, the Supervisor directed the Town Clerk to present that such notice has been duly published and posted; upon the order of the Supervisor such proof was duly filed.

The Supervisor announced that the Town Board would hear all persons interested in the subject of the hearing. Comments were heard, after which the Supervisor declared the hearing closed, decision was reserved.

RESULT: CLOSED [UNANIMOUS]
MOVER: Diane Benczkowski, Councilmember
SECONDER: James P. Rogowski, Councilmember
AYES: Holtz, Rogowski, Kaminski, Wozniak, Benczkowski, Meyers

2. Amend the Solid Waste Law - Local Law Intro No. 2014-5

COMMENTS - Current Meeting:

This being the time and place advertised for a Public Hearing, the Supervisor directed the Town Clerk to present that such notice has been duly published and posted; upon the order of the Supervisor such proof was duly filed.

The Supervisor announced that the Town Board would hear all persons interested in the subject of the hearing. Comments were heard, after which the Supervisor declared the hearing closed, decision was reserved.

RESULT: CLOSED [UNANIMOUS]
MOVER: Gerald Kaminski, Councilmember
SECONDER: Mary Holtz, Supervisor
AYES: Holtz, Rogowski, Kaminski, Wozniak, Benczkowski, Meyers

IV. Public Comment Period

V. Resolutions



1. RESOLUTION 2014-375

Transfer of Funds

Sponsored By: Supervisor Holtz, Councilmember Kaminski

BE IT RESOLVED, that the following transfer is hereby approved and made part hereof;

GENERAL

FROM:	100.1415.3500	State Aid Archive	\$69,404.00
	100.1356.1901	Board of Review	1,695.00
TO:	100.1415.1901	Regular Payroll	\$47,269.00
	100.1415.4500	Supplies	7,867.00
	100.1415.8000	Employee Benefits	3,857.00
	100.1415.2000	Equipment	10,411.00
	100.1355.4082	Seminars	1,695.00

HIGHWAY

FROM:	300.1910.2665	Revenue Account	\$5,400.00
TO:	300.5130.2407	Highway Equipment	\$5,400.00

CDBG

FROM:	700.1098.2200	Acquisition	\$1,314.00
	700.1006.2200	Property Purchases	500.00
	700.1098.0602	Clearance/Demolition	1,242.52
	700.1097.0730	Youth Companionship Program	464.00
	700.1004.2300	Temporary Relocation Assistance	501.00
	700.1005.0600	Housing Rehab.-Single Family	0.50
	700.1006.0606	Disposition	397.89
	700.1008.0753	Neighborhood Preservation Activities	1,287.96
TO:	700.1013.0600	Housing Rehab.-Single Family	\$5,707.87

RESULT:	ADOPTED [UNANIMOUS]
MOVER:	Mary Holtz, Supervisor
SECONDER:	Gerald Kaminski, Councilmember
AYES:	Holtz, Rogowski, Kaminski, Wozniak, Benczkowski, Meyers



2. RESOLUTION 2014-376

Warrant

Sponsored By: Supervisor Holtz, Councilmember Kaminski

BE IT RESOLVED, that the following Vouchers & Warrants submitted to the Town of Cheektowaga prior to July 7, 2014 are hereby approved and made part hereof;

GENERAL FUND	\$ 3,282,360.38
RISK RETENTION FUND	1,123,679.75
DEBT	1,023,984.50
HUD HOUSING REHABILITATION FUND	9.605.00
SPECIAL DISTRICTS FUND	4,079,222.44
HIGHWAY FUND	1,344,470.88
CAPITAL FUND	332,867.41
TRUST & AGENCY FUND	228,195.03
HUD CDBG FUND	59,975.63
PART TOWN FUND	214,024.40
	<hr/>
	\$11,698,385.42

RESULT:	ADOPTED [UNANIMOUS]
MOVER:	Mary Holtz, Supervisor
SECONDER:	Gerald Kaminski, Councilmember
AYES:	Holtz, Rogowski, Kaminski, Wozniak, Benczkowski, Meyers



3. RESOLUTION 2014-377

Amend Sidewalk Replacement Resolution to Delete Address

Sponsored By: Councilmember Kaminski, Supervisor Holtz

WHEREAS, by resolution dated June 2, 2014 (Resolution 2014-351), this Town Board directed certain property owners to repair the sidewalks in front of their homes or else the Town would repair said sidewalks and assess 60% of the costs thereof against the property, and

WHEREAS, 9 Fairelm Lane was mistakenly placed on the list attached to said resolution, NOW, THEREFORE, BE IT

RESOLVED, that the list attached to Resolution 2014-351 be and hereby revised by deleting therefrom the address of 9 Fairelm Lane.

RESULT:	ADOPTED [UNANIMOUS]
MOVER:	Gerald Kaminski, Councilmember
SECONDER:	Mary Holtz, Supervisor
AYES:	Holtz, Rogowski, Kaminski, Wozniak, Benczkowski, Meyers



4. RESOLUTION 2014-378

Amend Sidewalk Replacement Resolution to Delete Address

Sponsored By: Councilmember Kaminski, Supervisor Holtz

WHEREAS, by resolution dated June 16, 2014 (Resolution 2014-364), this Town Board directed certain property owners to repair the sidewalks in front of their homes or else the Town would repair said sidewalks and assess 60% of the costs thereof against the property, and

WHEREAS, 38 Brentwood Drive was mistakenly placed on the list attached to said resolution, NOW, THEREFORE, BE IT

RESOLVED, that the list attached to Resolution 2014-364 be and hereby revised by deleting therefrom the address of 38 Brentwood Drive.

RESULT:	ADOPTED [UNANIMOUS]
MOVER:	Gerald Kaminski, Councilmember
SECONDER:	Mary Holtz, Supervisor
AYES:	Holtz, Rogowski, Kaminski, Wozniak, Benczkowski, Meyers



5. RESOLUTION 2014-379

Adopt Local Law No. 4 of the Year 2014 - A Local Law to Amend the Zoning Law to Authorize the Police Department to Enforce Various Provisions Thereof

Sponsored By: Supervisor Holtz, Councilmember Kaminski

WHEREAS, by resolution dated January 21, 1992, Local Law No. 1 of the Year 1992 of the Town of Cheektowaga, entitled "A Local Law Relating to Zoning" was adopted, AND

WHEREAS, the Petitions Committee has recommended that the Zoning Law be amended to permit the Police Department to be able to cite and prosecute residential property owners who store unlicensed vehicles on their property, and people who erect signs on public property or on utility poles or trees; AND

WHEREAS, a draft of such amendment was prepared by the Town Attorney; AND

WHEREAS, a public hearing was held on the 7th day of July, 2014 at 6:45 P.M. at the Town Hall, 3301 Broadway, Cheektowaga, New York to consider the advisability of adopting "A Local Law to Amend the Zoning Law to Authorize the Police Department to Enforce Various Provisions Thereof", AND

WHEREAS, it is in the public interest to adopt said local law, NOW, THEREFORE, BE IT

RESOLVED, that Local Law No. 4 of the Year 2014, entitled "A Local Law to Amend the Zoning Law to Authorize the Police Department to Enforce Various Provisions Thereof" which is attached hereto and made a part hereof, be and the same is hereby enacted, and BE IT FURTHER

RESOLVED, that Local Law No. 4 of the Year 2014 shall be effective upon filing with the Secretary of State, and BE IT FURTHER

RESOLVED, that the Town Clerk shall file one (1) certified copy of this local law in her office and one (1) certified copy with the Secretary of State.

LOCAL LAW NO. 4 OF THE YEAR 2014
A LOCAL LAW TO AMEND THE ZONING LAW TO AUTHORIZE THE
POLICE DEPARTMENT TO ENFORCE VARIOUS PROVISIONS THEREOF

Section 260-68 of the Town Code (Zoning Law), **Administrative and enforcement officer**, shall be amended to read as follows:

A. Unless otherwise provided, the provisions of this chapter shall be administered and enforced by the Supervising Code Enforcement Officer and Code Enforcement Officers of the Town of Cheektowaga. The Code Enforcement Office/Building Inspections Department shall keep a

complete file of all applications, permits, orders, certificates, requirements and decisions affecting each and every application filed with the Town of Cheektowaga pursuant to this chapter.

B. The provisions of 260-28.J.(2), Section 260-50.D.(3) and Section 260-50.D.(8) shall also be enforced by the Police Department.

RESULT:	ADOPTED [UNANIMOUS]
MOVER:	Mary Holtz, Supervisor
SECONDER:	Gerald Kaminski, Councilmember
AYES:	Holtz, Rogowski, Kaminski, Wozniak, Benczkowski, Meyers



6. RESOLUTION 2014-380

Adopt Local Law No. 5 of the Year 2014 - A Local Law to Amend the Solid Waste Law of the Town of Cheektowaga

Sponsored By: Supervisor Holtz, Councilmember Kaminski

WHEREAS, by Local Law No. 5 of the Year 1992, the Cheektowaga Town Board enacted a Solid Waste Law (now known as Chapter 206 of the Code of the Town of Cheektowaga), AND

WHEREAS, The Petitions Committee has recommended that the Solid Waste Law be amended to permit the Police Department to enforce various provisions thereof, including provisions relating to illegal dumping and scavenging, AND

WHEREAS, a draft of such amendment was prepared by the Town Attorney, and

WHEREAS, a public hearing was held on the 7th day of July, 2014, at 6:45 P.M. at the Town Hall, 3301 Broadway, Cheektowaga, New York to consider the advisability of adopting "A Local Law to Amend the Solid Waste Law of the Town of Cheektowaga", AND

WHEREAS, it is in the public interest to adopt said local law, NOW, THEREFORE, BE IT

RESOLVED, that Local Law No. 5 of the Year 2014, entitled "A Local Law to Amend the Solid Waste Law of the Town of Cheektowaga", be and the same is hereby enacted, and BE IT FURTHER

RESOLVED, that Local Law No. 5 of the Year 2014 shall be effective upon filing with the Secretary of State, and BE IT FURTHER

RESOLVED, that the Town Clerk shall file one (1) certified copy of this local law in her office and one (1) certified copy with the Secretary of State.



LOCAL LAW NO. 5 OF THE YEAR 2014 **A LOCAL LAW TO AMEND THE SOLID WASTE LAW OF** **THE TOWN OF CHEEKTOWAGA**

Subsection E of Section 206-9, **Supervision; promulgation of rules and regulations**, of the Town Code ("Solid Waste"), shall be amended to add the following language thereto:

The Police Department officers are also authorized to enforce the provisions of this article, and shall be authorized to issue informational notices, warning notifications, violation notices and appearance tickets under this chapter.

RESULT:	ADOPTED [UNANIMOUS]
MOVER:	Mary Holtz, Supervisor
SECONDER:	Gerald Kaminski, Councilmember
AYES:	Holtz, Rogowski, Kaminski, Wozniak, Benczkowski, Meyers



7. RESOLUTION 2014-381

Award of Bid - Wastewater Pump - (Bid 2014-25)

Sponsored By: Councilmember Meyers, Supervisor Holtz

WHEREAS, bids were received on June 18, 2014 for the furnishing and delivery of one (1) new and unused 20 H.P. submersible, non-clog wastewater pump for the Sewer Maintenance Department (Bid 2014-25), AND

WHEREAS, said bids were referred to the Town Engineer for analysis, tabulation and report, which tabulation and report is contained in a letter from the Town Engineer dated June 25, 2014, NOW, THEREFORE, BE IT

RESOLVED, that the contract for the furnishing and delivery of one (1) new and unused 20 H.P. submersible, non-clog wastewater pump for the Sewer Maintenance Department be awarded to:

Xylem/Flygt
600 Mile Crossing Boulevard, Suite 3
Rochester, New York 14624

for submission of the lowest bid meeting the requirements of the specifications in the amount of \$12,482.00, AND, BE IT FURTHER

RESOLVED, that funds have been budgeted for the aforesaid pump purchase which shall be chargeable to the Consolidated Sanitary Sewer District Budget.

RESULT:	ADOPTED [UNANIMOUS]
MOVER:	Timothy J. Meyers, Councilmember
SECONDER:	Mary Holtz, Supervisor
AYES:	Holtz, Rogowski, Kaminski, Wozniak, Benczkowski, Meyers



8. RESOLUTION 2014-382

Negative SEQR Declaration -3101 Broadway Cameron

Sponsored By: Councilmember Meyers, Supervisor Holtz

WHEREAS, pursuant to the Environmental Impact Review Ordinance of the Town of Cheektowaga, the Environmental Advisory Committee ("EAC") reviews various applications for site plans, rezonings, special permits, etc. and renders its recommendation concerning the environmental significance of such application, AND

WHEREAS, an application was submitted by Scheid Architectural on behalf of Cameron for the construction of a 2,240 s.f. storage building and an 1,872 s.f. cooling tower facility at 3101 Broadway, AND

WHEREAS, the Town Board, pursuant to the Environmental Impact Review Ordinance of the Town of Cheektowaga, is designated the Lead Agency in most instances, AND

WHEREAS, since the Town Board is the Lead Agency, it must affirm, modify or reject any recommendations submitted to it by the Advisory Committee, AND

WHEREAS, the Town of Cheektowaga Planning Board recommended approval of the site plan at their meeting of June 12, 2014, AND

WHEREAS, the Environmental Advisory Committee at its meetings held on May 28, 2014 recommended a determination of non-significance as shown on the attached memorandum dated May 28, 2014, AND

WHEREAS, this Town Board has reviewed the application submitted and the recommendations made by the Environmental Advisory Committee and the Planning Board NOW, THEREFORE, BE IT

RESOLVED, that this Town Board determines that the project will not have a significant effect on the environment and therefore issues a Negative Declaration for purposes of the State Environmental Quality Review Act (SEQRA).

RESULT:	ADOPTED [UNANIMOUS]
MOVER:	Timothy J. Meyers, Councilmember
SECONDER:	Mary Holtz, Supervisor
AYES:	Holtz, Rogowski, Kaminski, Wozniak, Benczkowski, Meyers



9. RESOLUTION 2014-383

Accept Site Plan- 3101 Broadway Cameron

Sponsored By: Councilmember Benczkowski, Councilmember Rogowski

WHEREAS, pursuant to the Zoning Law of the Town of Cheektowaga, the Planning Board reviews various development review applications for site plans, rezonings, special permits and realty subdivisions and renders its recommendation concerning the compatibility of such application with the zoning regulations, the Town Master Plan and neighborhood character, AND

WHEREAS, the Town Board, pursuant to section 260-47.1C of the Zoning Law of the Town of Cheektowaga is vested with the authority to approve site plans and modify or reject any recommendation submitted to it by its advisory committees, AND

WHEREAS, Scheid Architectural on Behalf of Cameron submitted a development review application for the construction of a 2,240 SF storage building and a 1,872 s.f. cooling tower facility at 3101 Broadway, AND

WHEREAS, the Town of Cheektowaga Planning Board, reviewed and commented on the Application at their meeting of June 12, 2014 and have recommended approval thereof, NOW THEREFORE BE IT,

RESOLVED, that pursuant to Section 260-47-1 of the Code of the Town of Cheektowaga and Section 274-a of New York State Town Law that this Town Board approves the proposed site plan.

RESULT:	ADOPTED [UNANIMOUS]
MOVER:	Diane Benczkowski, Councilmember
SECONDER:	James P. Rogowski, Councilmember
AYES:	Holtz, Rogowski, Kaminski, Wozniak, Benczkowski, Meyers



10. RESOLUTION 2014-384

Call for Public Hearing - Rezoning Request - 805 Rein Road

Sponsored By: Councilmember Benczkowski, Councilmember Rogowski

WHEREAS, Chapin 805, LLC with the permission of the owner, Reinfirst Properties, LLC has made application and requested the rezoning of 805 Rein Road from M1- Light Manufacturing to MS- Motor Service district for the re-use of an existing warehouse for a truck repair/service facility, NOW, THEREFORE BE IT

RESOLVED, that a Public Hearing be held regarding said request under the provisions of the Zoning Law on July 21, 2014 at 6:45 P.M., at the Cheektowaga Town Hall, 3301 Broadway at the corner of Union Road.



Notice of Public Hearing

NOTICE IS HEREBY GIVEN that a Public Hearing will be held by the Town Board of the Town of Cheektowaga, Erie County, New York at the Town Hall in the said Town of Cheektowaga, 3301 Broadway corner of Union Road on the July 21, 2014 at 6:45 o'clock P.M., of said day for the purpose of considering the application of:

Chapin 805, LLC

for the rezoning of 805 Rein Road from M1- Light Manufacturing to MS- Motor Service for the re-use of an existing warehouse for a truck repair/service facility.

All parties in interest and citizens will be given an opportunity to be heard in regard to such proposed application.

BY ORDER OF THE TOWN BOARD, Town of Cheektowaga, NY

Alice Magierski, TOWN CLERK



All that tract or parcel of land situate in Town of Cheektowaga, County of Erie, and State of New York, All that tract or parcel of land situate in the Town of Cheektowaga, County of Erie and State of New York, being part of Lot No. 80 Township 11, Range 7 of the Holland Land Company's Survey, described as follows:-

Beginning at the intersection of the westerly line of Lot No. 80, (Being also the easterly line of Rein Road) and the center line of Ellicott Creek: running thence northerly along said westerly Lot No. 80, a distance of three hundred eleven (311) feet more or less to a point distance six hundred twenty and seventy-seven hundredths (622.77) feet south of the southerly line of Pfohls Road, Being also the southwest corner of lands conveyed to Warren E Lang by

deed recorded in Erie County Clerk's office in liber 7411 of Deeds page 383: running thence easterly parallel with said southerly line of Warren E Lang, two hundred and forty-seven (247) feet more or less to the center line of Ellicott Creek: running thence southerly and westerly along the center line of said creek, four hundred fifty-four and five tenths (454.5) feet to the point beginning.

RESULT:	ADOPTED [UNANIMOUS]
MOVER:	Diane Benczkowski, Councilmember
SECONDER:	James P. Rogowski, Councilmember
AYES:	Holtz, Rogowski, Kaminski, Wozniak, Benczkowski, Meyers



11. RESOLUTION 2014-385

Authorize Supervisor to Execute Second Amended Agreement with PBIRx

Sponsored By: Councilmember Kaminski, Supervisor Holtz

WHEREAS, in order to comply with the requirements of the Retiree Drug Subsidy Program for the purposes of obtaining federal funds, the Centers of Medicare Services requires governmental entities to have an agreement with health insurance carriers responsible for submitting claim information to the Centers for Medicare Services; and

WHEREAS, the Town of Cheektowaga has an existing HIPAA Business Associate Agreement with Sirowich & Associates, Inc., d/b/a PBIRx to perform these services for the Town, which Agreement was subsequently amended; and

WHEREAS, Congress recently approved additional requirements for safeguarding protected health information under HIPAA; and

WHEREAS, there is a need to further amend our agreement with PBIRx to comply with these recent mandates; and

WHEREAS, PBIRx has submitted a Second Amendment to the Business Associate Agreement, which Second Amendment has been reviewed by the Coordinator of Employee Relations and the Town Attorney; NOW, THEREFORE, BE IT

RESOLVED, that the Supervisor be and hereby is authorized and directed to execute the aforesaid Second Amendment to Business Associate Agreement with PBIRx, subject to the approval of the Town Attorney.

RESULT:	ADOPTED [UNANIMOUS]
MOVER:	Gerald Kaminski, Councilmember
SECONDER:	Mary Holtz, Supervisor
AYES:	Holtz, Rogowski, Kaminski, Wozniak, Benczkowski, Meyers



12. RESOLUTION 2014-386

Execute Final Contract Acceptance Documents with MKS Plumbing Corporation

Sponsored By: Supervisor Holtz, Councilmember Benczkowski

WHEREAS, the contract for the Plumbing Work at the Police and Court Building Renovation and Addition was awarded to MKS Plumbing Corporation by Town Board Resolution dated September 7, 2010, AND

WHEREAS, Trautman Associates (Project Architect) and the Town Engineer have advised that work under the aforesaid contract has been completed in accordance with the contract documents, NOW, THEREFORE, BE IT

RESOLVED, that this Town Board accepts the completed project and directs the Supervisor to execute final contract acceptance documents with MKS Plumbing Corporation, 19 Ransier Drive, West Seneca, New York 14224.

RESULT:	ADOPTED [UNANIMOUS]
MOVER:	Mary Holtz, Supervisor
SECONDER:	Diane Benczkowski, Councilmember
AYES:	Holtz, Rogowski, Kaminski, Wozniak, Benczkowski, Meyers



13. RESOLUTION 2014-387

Execute Final Contract Acceptance Documents with MLP Plumbing & Mechanical, Inc.

Sponsored By: Supervisor Holtz, Councilmember Benczkowski

WHEREAS, the contract for the HVAC Work at the Police and Court Building Renovation and Addition was awarded to MLP Plumbing & Mechanical, Inc. by Town Board Resolution dated September 7, 2010, AND

WHEREAS, Trautman Associates (Project Architect) and the Town Engineer have advised that work under the aforesaid contract has been completed in accordance with the contract documents, NOW, THEREFORE, BE IT

RESOLVED, that this Town Board accepts the completed project and directs the Supervisor to execute final contract acceptance documents with MLP Plumbing & Mechanical, Inc., 3198 Union Road, Cheektowaga, New York 14227.

RESULT:	ADOPTED [UNANIMOUS]
MOVER:	Mary Holtz, Supervisor
SECONDER:	Diane Benczkowski, Councilmember
AYES:	Holtz, Rogowski, Kaminski, Wozniak, Benczkowski, Meyers



14. RESOLUTION 2014-388

Approve Health Insurance Plan

Sponsored By: Supervisor Holtz, Councilmember Kaminski

WHEREAS, the Town of Cheektowaga is self insuring its health insurance with Blue Cross Blue Shield as the administrator, NOW THEREFORE, BE IT

RESOLVED, that this Town Board hereby approves the contents of the one (1) year administrative health insurance contract with Blue Cross Blue Shield, and BE IT FURTHER

RESOLVED, that this contract shall be effective as of August 1, 2014, and BE IT FURTHER

RESOLVED, that the Supervisor be and hereby is authorized and directed to execute the contract with Blue Cross Blue Shield, and any and all other documents necessary to effectuate the insurance coverage called for under such contract.

RESULT:	ADOPTED [UNANIMOUS]
MOVER:	Mary Holtz, Supervisor
SECONDER:	Gerald Kaminski, Councilmember
AYES:	Holtz, Rogowski, Kaminski, Wozniak, Benczkowski, Meyers



15. RESOLUTION 2014-389

Approve Purchase of Four (4) New and Unused 2014 S650 T4 Bobcats Skid-Steer Loaders

Sponsored By: Councilmember Kaminski, Supervisor Holtz

WHEREAS, the Highway Department currently owns four (4) 2013 S650 T4 Bobcat Skid-Steer Loaders purchased through New York State OSG contract PC 64705, AND

WHEREAS, said New York State OSG Contract PC 64075 runs through October 31 2015, AND

WHEREAS, Bobcat of Buffalo offers a one year trade-in program for said equipment as long as the New York State OSG Contract remains in effect, AND

WHEREAS, said trade-in program is based on the hours of use of equipment and any price increase in the New York State OSG Contract, AND

WHEREAS, the Highway Department has requested authorization to Trade-in four (4) 2013 S650 T4 Bobcat Skid-Steer Loaders for four (4) new and unused 2014 S650 T4 Bobcat Skid-Steer Loaders as specified under the terms of the Bobcat's trade-in program and New York State OSG Contract PC 64705, AND

WHEREAS, funds for said purchase have been budgeted and are available under account numbers 300-5130-2407 and 400-8140-4431, NOW THEREFORE BE IT

RESOLVED, that the Town Board hereby authorized to trade-in Four (4) 2013 S650 T4 Bobcat Skid-Steer Loaders for four (4) new and unused 2014 S650 T4 Bobcat Skid-Steer Loaders in the amount of \$12,896.00 from:

Bobcat of Buffalo
6511 South Transit Road
Lockport, NY 14094

RESULT:	ADOPTED [UNANIMOUS]
MOVER:	Gerald Kaminski, Councilmember
SECONDER:	Mary Holtz, Supervisor
AYES:	Holtz, Rogowski, Kaminski, Wozniak, Benczkowski, Meyers



16. RESOLUTION 2014-390

Approve STOP-DWI Agreement with Erie County for 2014-2016

Sponsored By: Councilmember Benczkowski, Councilmember Kaminski

WHEREAS, the County of Erie, pursuant to the authority granted to it by Article 43-A of the Vehicle and Traffic Law of the State of New York, has established a special options program for driving while intoxicated ("STOP-DWI"), and

WHEREAS, said program provides for the coordination of county, town, city and village efforts to reduce alcohol-related traffic accidents, including improvements in law enforcement and adjudication, increased education and other related activities, and

WHEREAS, Erie County has prepared and submitted to the Town for its approval a STOP-DWI Contract for calendar years 2014-2016, and

WHEREAS, the Town of Cheektowaga is interested in availing itself of funding under the STOP-DWI program and is also desirous of coordinating its efforts to reduce alcohol-related traffic injuries and fatalities with the County of Erie, NOW, THEREFORE, BE IT

RESOLVED, that the Town of Cheektowaga enter into the STOP-DWI Agreement which commences on January 1, 2014 and terminates on December 31, 2016 with the County of Erie concerning its STOP-DWI program, and BE IT FURTHER

RESOLVED, that the Supervisor be and hereby is authorized and directed to execute the STOP-DWI Agreement and any and all other papers necessary to implement the terms of this Agreement.

RESULT:	ADOPTED [UNANIMOUS]
MOVER:	Diane Benczkowski, Councilmember
SECONDER:	Gerald Kaminski, Councilmember
AYES:	Holtz, Rogowski, Kaminski, Wozniak, Benczkowski, Meyers



17. RESOLUTION 2014-391

Impediments to Fair Housing Study

Sponsored By: Supervisor Holtz, Councilmember Benczkowski

ANALYSIS OF IMPEDIMENTS TO FAIR HOUSING CHOICE AGREEMENTS

WHEREAS, the Towns of Amherst, Tonawanda, Cheektowaga, and Hamburg, including the Villages located therein, and Erie County receive over \$5,000,000 annually in federal Community Development Block Grant funds; and

WHEREAS, an important requirement for receiving federal funds is an Analysis of Impediments to Fair Housing Choice within recipient municipalities; and

WHEREAS, the aforementioned local governments and Erie County are desirous of conducting a joint Analysis of Impediments to Fair Housing Choice consistent with federal guidelines; and

WHEREAS, based on results from a Request for Proposal process conducted by the Department of Environment and Planning, and the Community Development Departments of the Towns of Amherst, Tonawanda, Cheektowaga, and Hamburg, the County Executive of Erie County is desirous of executing a contract in an amount not to exceed \$80,636 with Northeast and Bucks Company T/A Mullin & Lonergan Associates, Inc.; and

WHEREAS, funds for the Analysis will be federal Community Development Block Grant (CDBG) monies available to each municipality with contributions shown as follows:

- \$33,884 - Erie County
- \$13,834 - Town of Amherst
- \$13,834 - Town of Tonawanda
- \$13,834 - Town of Cheektowaga
- \$ 5,250 - Town of Hamburg
- \$80,636 - Total

WHEREAS, the County of Erie will act as the lead agency for coordinating the preparation of the Analysis of Impediments for the County and for each community, and

NOW, THEREFORE, BE IT RESOLVED, that the Town Supervisor be and hereby is authorized to execute an agreement with the County of Erie, 95 Franklin Street, Buffalo, New York 14202 for the purpose of carrying out Analysis of Impediments to Fair Housing Choice to include the Town of Cheektowaga for which the Town will pay an amount not to exceed \$13,834.

RESULT:	ADOPTED [UNANIMOUS]
MOVER:	Mary Holtz, Supervisor
SECONDER:	Diane Benczkowski, Councilmember
AYES:	Holtz, Rogowski, Kaminski, Wozniak, Benczkowski, Meyers



18. RESOLUTION 2014-392

Order Replacement of Sidewalks

Sponsored By: Councilmember Kaminski, Supervisor Holtz

WHEREAS, Chapter 210 of the Code of the Town of Cheektowaga (Streets and Sidewalks) sets forth the specifications for the construction of sidewalks in the Town of Cheektowaga, and

WHEREAS, Section 200-a of the Town Law of the State of New York authorizes a town board to adopt a local law to apportion the expense of building, relaying and repairing sidewalks in towns between the town and property owners, and

WHEREAS, this Town Board, by Local Law No. 4 of the Year 1991 and Local Law No. 5 of the Year 2008 (amended by Local Law No. 3 of the Year 2013), adopted provisions to apportion the cost of relaying or repairing sidewalks in the Town of Cheektowaga between the Town and property owners, and

WHEREAS, the Town Superintendent of Highways has notified this Town Board that sidewalk block(s) located at 42 Brentwood Drive are in need of repair or replacement, NOW, THEREFORE, BE IT

ORDERED, that the owner(s) of property located at 42 Brentwood Drive be and hereby are directed to repair/replace the sidewalks abutting such property on or before August 4, 2014, in accordance with the Town's Streets and Sidewalks Law, and BE IT FURTHER

ORDERED, that, should such property owners neglect to or choose to not repair/replace their sidewalks as so notified before August 4, 2014, the Town will cause such sidewalks to be repaired/replaced; will pay \$46.40-51.20 for each 5-foot linear block repaired/replaced; and will assess/charge the property owner the balance over a period of five (5) years on the County/Town tax bill, with interest at the rate of 6.00 % as authorized by State law; or, at the property owner's option, payment may be made in one lump sum before October 14, 2014, and BE IT FURTHER

ORDERED, that the Town Clerk be and hereby is directed to notify the owners of 42 Brentwood Drive of the adoption of this Order by sending the attached Notice via certified mail to each owner at his/her/their address as it appears on the Town Assessment Roll.

**NOTICE OF ADOPTION OF ORDER
OF THE TOWN BOARD OF THE TOWN OF CHEEKTOWAGA**

TAKE NOTICE THAT, pursuant to a resolution adopted by the Town Board of the Town of Cheektowaga on July 7, 2014,

YOU ARE HEREBY ORDERED to repair the sidewalk in front of your property.

Such work must be completed on or before **August 4, 2014.**

In the event you neglect or choose not to perform this work before the specified

date, be advised that the Town of Cheektowaga shall cause such work to be done. The Town will audit and pay \$46.40-\$51.20 for each 5-foot linear block replaced; and will assess the remaining expense thereof (including interest at the rate of 6.00%) against your property in five (5) annual installments; this amount will be added to your town tax bills for the next five (5) years and shall become a lien on your property. In the alternative, you may pay your share of the cost directly to the Town provided you do so on or before October 14, 2014. You will be notified of the amount you owe for sidewalk repairs.

If the Town performs the work, it is estimated that your cost for sidewalk repair will be approximately \$69.60-\$76.80 per 5-foot linear block of sidewalk.

If you choose to perform the work yourself or have a contractor perform such work, be advised that you will be responsible for paying 100% of the cost of the sidewalk work **(the Town will not pay anything towards your cost).**

BY ORDER OF THE TOWN BOARD OF THE TOWN OF CHEEKTOWAGA, ERIE COUNTY, NEW YORK.

DATED: July 7, 2014

ALICE MAGIERSKI
Town Clerk

RESULT:	ADOPTED [UNANIMOUS]
MOVER:	Gerald Kaminski, Councilmember
SECONDER:	Mary Holtz, Supervisor
AYES:	Holtz, Rogowski, Kaminski, Wozniak, Benczkowski, Meyers



19. RESOLUTION 2014-393

Special Event - Pulaski Day Parade

Sponsored By: Councilmember Meyers, Councilmember Rogowski

WHEREAS, the General Pulaski Association has made application to hold a parade honoring General Pulaski on Sunday, July 20th, 2014 at 1:30 p.m. beginning at the Thruway Plaza; then proceeding west on Walden Avenue; then north on Harlem Road to Cheektowaga Town Park, and

WHEREAS, this Board has reviewed the aforementioned application, which application has been approved by the Police Department, Highway Department and Facilities Department and has no objection to same, and

WHEREAS, due to the nature of the event, this Town Board hereby waives the following requirements:

- . Submittal of plan for sanitary facilities;
- . Submittal of site plan;
- . Submittal of Security Plan;
- . Submittal of Fire Prevention/Emergency Services Plan;

NOW, THEREFORE, BE IT

RESOLVED, that this Town Board Hereby approves the aforementioned application of the General Pulaski Association for the aforementioned parade to be held on Sunday, July 20th, 2014 and BE IT FURTHER

RESOLVED, that the Chief of Police be and hereby is directed to provide traffic safety and escort services for such parade and to ensure compliance with Section 1660(a)(6) of the Vehicle and Traffic Law.

RESULT:	ADOPTED [UNANIMOUS]
MOVER:	Timothy J. Meyers, Councilmember
SECONDER:	James P. Rogowski, Councilmember
AYES:	Holtz, Rogowski, Kaminski, Wozniak, Benczkowski, Meyers



20. RESOLUTION 2014-394

Special Event - Trooper Jill Farrar-Mattice Memorial Run

Sponsored By: Councilmember Meyers, Councilmember Rogowski

WHEREAS, by resolution dated May 1, 1995, this Town Board adopted a Special Events policy, which requires anyone wishing to hold a special event in the Town to file an application and supporting documentation, fees, etc. to the Town Clerk prior to the special event, AND

WHEREAS, Jeffrey Farrar has made application to hold the "Trooper Jill Farrar-Mattice Memorial 5-K Run" on Saturday, September 27, 2014 from 8:00 a.m. until 2:00 p.m. to raise funds to benefit the scholarship fund established at Cleveland Hill High School in memory of Trooper Jill Farrar-Mattice, AND

WHEREAS, this Board has reviewed the aforementioned application, which application has been approved by the Police Department and Highway Department and has no objection to same, AND

WHEREAS, due to the nature of the event, this Town Board hereby waives the following requirements:

- 1) Submittal of plan for sanitary facilities;
- 2) Submittal of site plan;
- 3) Requirement that application be made at least 60 days prior to the date of the special event;
- 4) Submittal of Security Plan;
- 5) Submittal of Fire Prevention/Emergency Services Plan; NOW, THEREFORE, BE

IT

RESOLVED, that this Town Board hereby approves the aforementioned application of Jeffrey Farrar for the "Trooper Jill Farrar-Mattice Memorial 5-K Run" on Saturday, September 27, 2014; AND BE IT FURTHER

RESOLVED, that the Chief of Police be and hereby is directed to provide traffic safety and escort services for such run and to ensure compliance with Section 1600(a)(6) of the Vehicle and Traffic Law.

RESULT:	ADOPTED [UNANIMOUS]
MOVER:	Timothy J. Meyers, Councilmember
SECONDER:	James P. Rogowski, Councilmember
AYES:	Holtz, Rogowski, Kaminski, Wozniak, Benczkowski, Meyers



21. RESOLUTION 2014-395

Youth & Recreation Hire/Transfer

Sponsored By: Councilmember Wozniak, Councilmember Rogowski

BE IT RESOLVED that the individuals listed below be and hereby are hired, as indicated, in the Department of Youth & Recreational Services, effective immediately:

Lifeguard - Level I - 7180.1903 - \$9.00 - Seasonal

Kristina Doetterl 14227

Lifeguard - Level I - 7180.1903 - \$9.00 - Seasonal - Retro to 6/22/14

Kevin Lopez-Rodriguez 14225

Lifeguard - Level IV - 7180.1903 - \$9.55 - Seasonal

Catherine Huber 14225

Recreation Attendant - 7140.1632 Camp Dartwood - \$8.00 - Seasonal - Retro to 7/2/14

Andrea O'Shea 14043

Recreation Attendant - 7140.1633 - \$8.75 - Regular Part-time

Joel Greenauer 14227

BE IT FURTHER RESOLVED that the individual listed below be and hereby transferred, as indicated, in the Department of Youth & Recreational Services, effective immediately:

Recreation Attendant 7310.1814 to Recreation Attendant 7310.1811 (CCC) - \$13.25 - Regular Part-time - Retro to 6/27/14

Nicholas Russell

Recreation Attendant - 7140.1646 - \$9.25 - Regular Part-time

Josh Strzelec

Motion by Councilmember Rogowski; Seconded by Councilmember Benczkowski to waive the reading of names for the following two (2) resolutions: 2014-395 and 2014-396. Motion carried.

RESULT: ADOPTED [UNANIMOUS]
MOVER: Angela M. Wozniak, Councilmember
SECONDER: James P. Rogowski, Councilmember
AYES: Holtz, Rogowski, Kaminski, Wozniak, Benczkowski, Meyers



22. RESOLUTION 2014-396

Hiring/Termination of Part Time/Seasonal Employees

Sponsored By: Councilmember Kaminski, Supervisor Holtz

BE IT RESOLVED, that the following individuals be and hereby are hired as **SEASONAL EMPLOYEES**, not to exceed five (5) months in a calendar year, in the various departments listed and in compliance with Civil Service Laws and Regulations as well as the provisions of the Town's collective bargaining agreement between the Town of Cheektowaga and the Town of Cheektowaga Employees Association:

SANITATION DEPARTMENT Laborer \$9.25/hour
Brian K. O'Connor, Sloan, New York effective 6/23/14
Mark S. Urbanski, Cheektowaga, New York effective 6/13/14
Kyle J. Kehoe, Cheektowaga, New York effective 6/16/14
Jordan C. Maund, Cheektowaga, New York effective 6/16/14

FACILITIES DEPARTMENT (Building and Grounds Division) Laborer \$8.25/hour effective 7/8/14
Ryan E. Pocobello, Cheektowaga, New York

FACILITIES DEPARTMENT (Parks Division) Laborer \$9.00/hour effective 7/8/14
Eric J. Tomczak, Cheektowaga, New York

BE IT RESOLVED, that the following individuals be and hereby are hired as **PART-TIME EMPLOYEES** in the departments listed, not to exceed nineteen (19) hours on a weekly basis, in compliance with Civil Service Laws and Regulations as well as the provisions of the Town's collective bargaining agreement between the Town of Cheektowaga and the Town of Cheektowaga Employees Association:

POLICE DEPARTMENT Police Attendant \$15.00/hour effective 7/7/14
Julia M. Beecroft, Cheektowaga, New York

POLICE DEPARTMENT Police Attendant \$17.00/hour effective 6/16/14
Deric Demyanick, Cheektowaga, New York

BE IT RESOLVED, that the following seasonal and/or part-time employees be and hereby are terminated as listed:

POLICE DEPARTMENT
Madelyn O. Pecyne effective 6/30/14
Samantha L. Stroud effective 6/28/14
Sara L. Mays effective 6/17/14

SENIOR SERVICES
Janine M. Kiedel effective 6/21/14

FACILITIES DEPARTMENT

Bryan C. Haxton effective 5/10/14
Christian J. Suszek effective 6/2/14
Andrew M. Mays effective 6/4/14
James K. Stoll effective 5/8/14

SANITATION DEPARTMENT

Christopher M. Vail effective 6/11/14
Anthony F. Chiarmonte effective 6/12/14
Derek R. Dalka effective 6/10/14
Joshua A. Parra effective 6/14/14
Romaine D. Harris, Jr. effective 6/14/14

RESULT:	ADOPTED [UNANIMOUS]
MOVER:	Gerald Kaminski, Councilmember
SECONDER:	Mary Holtz, Supervisor
AYES:	Holtz, Rogowski, Kaminski, Wozniak, Benczkowski, Meyers



23. RESOLUTION 2014-397

Appointment to Cheektowaga Economic Development Corporation Directors

Sponsored By: Councilmember Benczkowski, Supervisor Holtz

WHEREAS, the Town Board of the Town of Cheektowaga previously created the Cheektowaga Economic Development Corporation for the purpose of assisting and encouraging economic development within the Town, and

WHEREAS, By Resolution dated February 7, 1983 this Town Board approved the By-Laws of the Cheektowaga Economic Development Corporation which provide that the Directors of the Cheektowaga Economic Development Corporation be appointed by resolution of the Cheektowaga Town Board, and

WHEREAS, the Cheektowaga Economic Development Corporation Board of Directors has unanimously recommended the appointment of the individuals listed below to the Board of Directors of the Cheektowaga Economic Development Corporation for a term of three years, NOW, THEREFORE, BE IT

RESOLVED, that the following individual is hereby appointed to the Board of Directors of the Cheektowaga Economic Development Corporation, effective immediately for a term of two years, said term expiring at the time of reappointment to said Board of Directors positions in 2016, but no later than June 30, 2016:

Jeffrey C. Mendola

RESULT:	WITHDRAWN
----------------	------------------



24. RESOLUTION 2014-398

Appoint Inspector for Unsafe Buildings

Sponsored By: Councilmember Benczkowski, Supervisor Holtz

WHEREAS, the Town of Cheektowaga is pursuing the demolition of unsafe and abandoned homes in the Town, and

WHEREAS, pursuant to the Town's Unsafe Buildings Law, the Supervising Code Enforcement Officer, his designees or other person appointed by the Town Board is authorized to make an inspection of any suspected unsafe building in the Town and report, in writing, to this Town Board, findings and recommendations concerning the necessity to demolish said building, and'

WHEREAS, Richard Willis, Code Enforcement Officer for the Town's Department of Community Development and Neighborhood Preservation, wishes to perform these services for the Town of Cheektowaga, NOW, THEREFORE, BE IT

RESOLVED, that this Town Board hereby appoints Richard Willis, Code Enforcement Officer for the Town's Department of Community Development and Neighborhood Preservation, to perform the aforementioned services under the Town's Unsafe Buildings Law.

RESULT:	ADOPTED [UNANIMOUS]
MOVER:	Diane Benczkowski, Councilmember
SECONDER:	Mary Holtz, Supervisor
AYES:	Holtz, Rogowski, Kaminski, Wozniak, Benczkowski, Meyers



25. RESOLUTION 2014-399

Appointment of Assistant Field Assessor (Provisional)/Office of the Town Assessor/Jill M. Oxley

Sponsored By: Councilmember Benczkowski, Councilmember Kaminski

WHEREAS, a vacancy exists in the title of Assistant Field Assessor in the Office of the Town Assessor; AND

WHEREAS, notice of said vacancy has been posted in accordance with the provisions of the Town's collective bargaining agreement with the Town of Cheektowaga Employees Association; AND

WHEREAS, no civil service list for said title currently exists; AND

WHEREAS, Jill M. Oxley, currently employed as a Senior Assessment Clerk, bid on said vacancy and meets the qualifications for provisional appointment; NOW, THEREFORE, BE IT

RESOLVED, that Jill M. Oxley of Cheektowaga, New York, be and hereby is appointed to the provisional position of Assistant Field Assessor in the Office of the Town Assessor in compliance with the terms and conditions of the collective bargaining agreement between the Town and the Town of Cheektowaga Employees Association effective July 8, 2014.

RESULT:	ADOPTED [UNANIMOUS]
MOVER:	Diane Benczkowski, Councilmember
SECONDER:	Gerald Kaminski, Councilmember
AYES:	Holtz, Rogowski, Kaminski, Wozniak, Benczkowski, Meyers



26. RESOLUTION 2014-400

Appointment of Assessment Clerk (Provisional)/Office of the Town Assessor/Michael G. Milks

Sponsored By: Councilmember Benczkowski, Councilmember Kaminski

WHEREAS, a vacancy exists in the title of Assessment Clerk in the Office of the Town Assessor; AND

WHEREAS, notice of said vacancy has been posted in accordance with the provisions of the Town's collective bargaining agreement with the Town of Cheektowaga Employees Association; AND

WHEREAS, no civil service list for said title currently exists; AND

WHEREAS, no bargaining unit employee bid on said vacancy; AND

WHEREAS, Michael G. Milks, currently employed as a Clerk (Part Time) in the Office of the Town Assessor, applied for said vacancy and meets the qualifications for provisional appointment; NOW, THEREFORE, BE IT

RESOLVED, that Michael G. Milks of Cheektowaga, New York, be and hereby is appointed to the provisional position of Assessment Clerk in the Office of the Town Assessor in compliance with the terms and conditions of the collective bargaining agreement between the Town and the Town of Cheektowaga Employees Association effective July 8, 2014.

RESULT:	ADOPTED [UNANIMOUS]
MOVER:	Diane Benczkowski, Councilmember
SECONDER:	Gerald Kaminski, Councilmember
AYES:	Holtz, Rogowski, Kaminski, Wozniak, Benczkowski, Meyers



27. RESOLUTION 2014-401

Appointment of Maintenance Worker (Temporary) Facilities Department (Buildings and Grounds Division)

Sponsored By: Councilmember Rogowski, Councilmember Kaminski

WHEREAS, a temporary Maintenance Worker position exists in the Facilities Department (Buildings and Grounds Division); AND

WHEREAS, notice of such vacancy has been posted in accordance with the provisions of the Town's collective bargaining agreement with the Town of Cheektowaga Employees Association; AND

WHEREAS, no bargaining unit member bid on the vacancy; AND

WHEREAS, Tyler M. Pocobello of Cheektowaga, New York, currently employed as a Laborer (Part Time) in the Facilities Department, applied for said vacancy and meets the qualifications for appointment; NOW, THEREFORE, BE IT

RESOLVED, that Tyler M. Pocobello of Cheektowaga, New York be and hereby is appointed to the temporary position of Maintenance Worker in the Facilities Department (Buildings and Grounds Division) in accordance with the terms and conditions of the Town's collective bargaining agreement with the Town of Cheektowaga Employees Association effective July 8, 2014.

RESULT:	ADOPTED [UNANIMOUS]
MOVER:	James P. Rogowski, Councilmember
SECONDER:	Gerald Kaminski, Councilmember
AYES:	Holtz, Rogowski, Kaminski, Wozniak, Benczkowski, Meyers



28. RESOLUTION 2014-402

Travel Authorization Police Department/Police Officer Donald Szumigala

Sponsored By: Councilmember Benczkowski, Councilmember Kaminski

WHEREAS, the NYSIC Open Source Practitioner's Course is being held July 15 through July 16, 2014 in East Greenbush, New York; AND

WHEREAS, Police Officer Donald Szumigala has requested approval to attend said course; AND

WHEREAS, Police Chief David Zack has submitted a request for travel authorization along with the proper paperwork in a timely manner; AND

WHEREAS, the total cost to the Town shall not exceed \$417; AND

WHEREAS, these expenses have been budgeted by the Department; NOW, THEREFORE, BE IT

RESOLVED, that Police Officer Donald Szumigala be and hereby is authorized to attend the NYSIC Open Source Practitioner's Course being held July 15 through July 16, 2014 in East Greenbush, New York.

RESULT:	ADOPTED [UNANIMOUS]
MOVER:	Diane Benczkowski, Councilmember
SECONDER:	Gerald Kaminski, Councilmember
AYES:	Holtz, Rogowski, Kaminski, Wozniak, Benczkowski, Meyers



29. RESOLUTION 2014-403

Travel Authorization Police Department/Police Officers Thomas Rogers and Jacob Gawronski

Sponsored By: Councilmember Benczkowski, Councilmember Kaminski

WHEREAS, the Remington Armorer School is being held August 19 through August 22, 2014 in Ilion, New York; AND

WHEREAS, Police Officers Thomas Rogers and Jacob Gawronski have been recommended to attend said school; AND

WHEREAS, Police Chief David Zack has submitted a request for travel authorization along with the proper paperwork in a timely manner; AND

WHEREAS, the total cost to the Town shall not exceed \$2,269; AND

WHEREAS, these expenses have been budgeted by the Department; NOW, THEREFORE, BE IT

RESOLVED, that Police Officers Thomas Rogers and Jacob Gawronski be and hereby are authorized to attend the Remington Armorer School being held August 19 through August 22, 2014 in Ilion, New York.

RESULT:	ADOPTED [UNANIMOUS]
MOVER:	Diane Benczkowski, Councilmember
SECONDER:	Gerald Kaminski, Councilmember
AYES:	Holtz, Rogowski, Kaminski, Wozniak, Benczkowski, Meyers

VI. Suspension of Rules

Motion by Councilmember Rogowski; Seconded by Councilmember Meyers to Waive the Rules to Include the following resolution: 2014-404. Motion Carried.



1. RESOLUTION 2014-404

Notice of Hearing for Demolition of 67 A-D Windwood Court

Sponsored By: Supervisor Holtz, Councilmember Benczkowski

WHEREAS, the Supervising Code Enforcement Officer has received information that the building located at 67 A-D Windwood Court in the Town of Cheektowaga (S.B.L. No. 91.14-2-21) has become dangerous and unsafe to the general public and unfit for the purposes for which it may lawfully be used; and

WHEREAS, said building has been inspected and a written report of the condition has been completed by Nussbaumer & Clarke, Inc., duly authorized agent of the Town of Cheektowaga, setting forth its findings and recommendations in regard to the repair or demolition and removal of the building, and said written report describes extensive deterioration and damage to the building and premises and recommends that the building be demolished and removed as soon as possible; and

WHEREAS, the Town Board has fully considered such written report and has determined that the building is dangerous and unsafe to the general public and unfit for the purposes for which it may lawfully be used; NOW THEREFORE BE IT

RESOLVED, that this Town Board accepts the findings and recommendations of Nussbaumer & Clarke, Inc., dated December 2, 2013; and BE IT FURTHER

RESOLVED, that a notice shall be served, pursuant to Section 75-7 of the Cheektowaga Town Code, upon the owner, executor, administrator, agent, lessee or any person having a vested or contingent interest in such unsafe building as shown by the records of the Receiver of Taxes or of the County Clerk, which notice shall have the contents prescribed by Section 75-6 of said Town Code, including, but not limited to a date, time and place for a hearing before the Town Board in relation to such dangerous and unsafe building, which hearing shall be scheduled not less than five business days from the date of service of the notice; and BE IT FURTHER

RESOLVED, that a hearing before this Board in relation to this dangerous and unsafe building shall be held on the 21st day of July 2014 at 6:45 P.M. at the Cheektowaga Town Hall, 3301 Broadway, Cheektowaga, New York, and BE IT FURTHER

RESOLVED, that the Code Enforcement Office and/or the Town Attorney's Office be and hereby are directed to serve notice of said hearing on all interested parties.

RESULT:	ADOPTED [UNANIMOUS]
MOVER:	Mary Holtz, Supervisor
SECONDER:	Diane Benczkowski, Councilmember
AYES:	Holtz, Rogowski, Kaminski, Wozniak, Benczkowski, Meyers

VII. Communications

A. Departmental Communications

1. **Supervisor's Statement of Funds - May 2014**
2. **Building Permit List - June 2014**
3. **Minutes: Cheektowaga Planning Board - June 12, 2014**
4. **Town of Cheektowaga Community Development Block Grant Program - Draft Consolidated Annual Performance and Evaluation Report - 2013 Program Year**
5. **Town of Cheektowaga Community Development Block Grant Program - Consolidated Annual Performance and Evaluation Report - 2013 Program Year**

B. General Communications

1. **Notice of Claim: Autozone Inc. #2913 vs. Town of Cheektowaga**
2. **Notice of Claim: Joseph S. Ferraro vs. Town of Cheektowaga**
3. **Notice of Claim: Gail Godfrey vs. Town of Cheektowaga**
4. **Notice of Claim: Progressive Insurance for Kelly Hernandez vs. Town of Cheektowaga**
5. **Notice of Claim: Louis P. Resofsky vs. Town of Cheektowaga**
6. **Notice of Claim: Christine A. Reynolds vs. Town of Cheektowaga**
7. **Request to Speak: David Walczak regarding Taxicab Law**

VIII. Comments

A. Supervisor's Comments

B. Councilmember's Comments

C. Public Comments

IX. Adjourn

Motion by Councilmember Rogowski; Seconded by Councilmember Kaminski to adjourn the meeting at 7:59 PM.

Alice Magierski, Town Clerk



Town of Cheektowaga

Work Session

~ Minutes ~

3301 Broadway
Cheektowaga, NY 14227
<http://www.town.cheektowaga.ny.us>

Alice Magierski
716-686-3400

Tuesday, July 15, 2014

6:00 PM

Council Office

I. Call to Order

6:00 PM Meeting called to order on July 15, 2014 at Council Office, Conference Room, Cheektowaga, NY.

Attendee Name	Organization	Title	Status	Arrived
Mary Holtz	Town of Cheektowaga	Supervisor	Present	
James P. Rogowski	Town of Cheektowaga	Councilmember	Present	
Gerald Kaminski	Town of Cheektowaga	Councilmember	Present	
Angela M. Wozniak	Town of Cheektowaga	Councilmember	Present	
Diane Benczkowski	Town of Cheektowaga	Councilmember	Present	
Timothy J. Meyers	Town of Cheektowaga	Councilmember	Present	

II. Public Portion

III. Resolutions



1. RESOLUTION 2014-405

Termination of Deputy Town Attorney/Prosecutor

Sponsored By: Councilmember Kaminski, Supervisor Holtz

BE IT RESOLVED, that Anthony S. Pecoraro, Esq. be and hereby is terminated from the position of Deputy Town Attorney (with prosecutorial duties), effective immediately.

RESULT:	ADOPTED [UNANIMOUS]
MOVER:	Gerald Kaminski, Councilmember
SECONDER:	Mary Holtz, Supervisor
AYES:	Holtz, Rogowski, Kaminski, Wozniak, Benczkowski, Meyers



2. RESOLUTION 2014-406

Appoint Deputy Town Attorney/Prosecutor

Sponsored By: Councilmember Kaminski, Supervisor Holtz

WHEREAS, there is a vacancy in one of the positions of Deputy Town Attorney (with prosecutorial duties), and

WHEREAS, Nicholas A. Romano, Esq. has applied for said position and meets all necessary qualifications for same, NOW, THEREFORE, BE IT

RESOLVED, that Nicholas A. Romano, Esq., of Cheektowaga, New York, be and hereby is appointed Deputy Town Attorney (with prosecutorial duties) at the salary established for said position, effective immediately.

RESULT:	ADOPTED [UNANIMOUS]
MOVER:	Gerald Kaminski, Councilmember
SECONDER:	Mary Holtz, Supervisor
AYES:	Holtz, Rogowski, Kaminski, Wozniak, Benczkowski, Meyers



Town of Cheektowaga

Regular Meeting

~ Minutes ~

3301 Broadway
Cheektowaga, NY 14227
<http://www.town.cheektowaga.ny.us>

Alice Magierski
716-686-3400

Monday, July 21, 2014

6:45 PM

Council Chambers

I. Call to Order

6:45 PM Meeting called to order on July 21, 2014 at Council Chambers, 3301 Broadway St, Cheektowaga, NY.

Attendee Name	Organization	Title	Status	Arrived
Mary Holtz	Town of Cheektowaga	Supervisor	Present	
James P. Rogowski	Town of Cheektowaga	Councilmember	Present	
Gerald Kaminski	Town of Cheektowaga	Councilmember	Present	
Angela M. Wozniak	Town of Cheektowaga	Councilmember	Present	
Diane Benczkowski	Town of Cheektowaga	Councilmember	Present	
Timothy J. Meyers	Town of Cheektowaga	Councilmember	Present	

2. Additional Attendees

Patrick Bowen, Assistant Town Engineer
Robert Brandon, Zoning Board Chairman
Carla A. Kosmerl, Director of Community Development
Brian Krause, Director of Finance and Administration
Kevin Schenk, Town Attorney
James Speyer, Assistant Chief of Police
Mark Wegner, Highway Superintendent

II. Public Comment Period

III. Public Hearings

1. Rezoning Request - 805 Rein Road from M1 to MS

COMMENTS - Current Meeting:

This being the time and place advertised for a Public Hearing, the Supervisor directed the Town Clerk to present that such notice has been duly published and posted; upon the order of the Supervisor such proof was duly filed.

The Supervisor announced that the Town Board would hear all persons interested in the subject of the hearing. Comments were heard, after which the Supervisor declared the hearing closed, decision was reserved.

RESULT: CLOSED [UNANIMOUS]
MOVER: Diane Benczkowski, Councilmember
SECONDER: James P. Rogowski, Councilmember
AYES: Holtz, Rogowski, Kaminski, Wozniak, Benczkowski, Meyers

2. Demolition of 67 A-D Windwood Court

COMMENTS - Current Meeting:

This being the time and place advertised for a Public Hearing, the Supervisor directed the Town Clerk to present that such notice has been duly published and posted; upon the order of the Supervisor such proof was duly filed.

The Supervisor announced that the Town Board would hear all persons interested in the subject of the hearing. Comments were heard, after which the Supervisor declared the hearing closed, decision was reserved.

RESULT: CLOSED [UNANIMOUS]
MOVER: Mary Holtz, Supervisor
SECONDER: Diane Benczkowski, Councilmember
AYES: Holtz, Rogowski, Kaminski, Wozniak, Benczkowski, Meyers

IV. Resolutions



1. RESOLUTION 2014-407

Warrant

Sponsored By: Councilmember Kaminski, Supervisor Holtz

BE IT RESOLVED, that the following Vouchers & Warrants submitted to the Town of Cheektowaga prior to July 21, 2014 are hereby approved and made part hereof;

GENERAL FUND	\$294,546.91
RISK RETENTION FUND	225,327.26
NYS HOME PROGRAM	0.00
DEBT	0.00
HUD HOUSING REHABILITATION FUND	0.00
SPECIAL DISTRICTS FUND	283,097.67
HIGHWAY FUND	67,784.86
CAPITAL FUND	295,312.08
TRUST & AGENCY FUND	53,449.45
HUD CDBG FUND	466.17
PART TOWN FUND	1,875.33
NYS AFFORDABLE HOUSING	0.00
	<hr/>
	\$1,221,859.73

RESULT:	ADOPTED [UNANIMOUS]
MOVER:	Gerald Kaminski, Councilmember
SECONDER:	Mary Holtz, Supervisor
AYES:	Holtz, Rogowski, Kaminski, Wozniak, Benczkowski, Meyers



2. RESOLUTION 2014-408

Negative SEQR Declaration - 805 Rein Road

Sponsored By: Councilmember Meyers, Supervisor Holtz

WHEREAS, pursuant to the Environmental Impact Review Ordinance of the Town of Cheektowaga, the Environmental Advisory Committee ("EAC") reviews various applications for site plans, rezonings, special permits, etc. and renders its recommendation concerning the environmental significance of such application, AND

WHEREAS, an application was submitted by Chapin 805, LLC for the rezoning of 805 Rein Road from M1-Light Manufacturing to MS-Motor Service to permit the conversion of an existing warehouse building to a truck repair and truck part sales facility, AND

WHEREAS, the Town Board, pursuant to the Environmental Impact Review Ordinance of the Town of Cheektowaga, is designated the Lead Agency in most instances, AND

WHEREAS, since the Town Board is the Lead Agency, it must affirm, modify or reject any recommendations submitted to it by the Advisory Committee, AND

WHEREAS, the Town of Cheektowaga Planning Board recommended approval of the rezoning request at their meeting of June 12, 2014, AND

WHEREAS, the Environmental Advisory Committee at its meetings held on June 25, 2014 recommended a determination of non-significance as shown on the attached memorandum dated June 25, 2014, AND

WHEREAS, this Town Board has reviewed the application submitted and the recommendations made by the Environmental Advisory Committee and the Planning Board NOW, THEREFORE, BE IT

RESOLVED, that this Town Board determines that the project will not have a significant effect on the environment and therefore issues a Negative Declaration for purposes of the State Environmental Quality Review Act (SEQRA).

RESULT:	ADOPTED [UNANIMOUS]
MOVER:	Timothy J. Meyers, Councilmember
SECONDER:	Mary Holtz, Supervisor
AYES:	Holtz, Rogowski, Kaminski, Wozniak, Benczkowski, Meyers



3. RESOLUTION 2014-409

Approval of Rezoning - 805 Rein Road

Sponsored By: Councilmember Benczkowski, Councilmember Meyers

WHEREAS, Chapin 805, LLC petitioned for a rezoning from M2-General Manufacturing District to MS-Motor Services District for property owned by Reinfirst Properties, LLC and identified as 805 Rein Road, Cheektowaga, New York, which property is described in the attached legal description, to permit the conversion of an existing warehouse building to a truck repair and truck parts sales facility, AND

WHEREAS, a public hearing on such petition was held before this Town Board on the 21st day of July, 2014 at 6:45 P.M., after publication and service of the notices required by the provisions of the Code of the Town of Cheektowaga ("Zoning Law"), and the Town Law; and all interested parties were given an opportunity to be heard at such hearing, AND

WHEREAS, the Cheektowaga Planning Board has reviewed such application and has recommended approval thereof, AND

WHEREAS, this Town Board previously issued a Negative Declaration under SEQRA and the Town Environmental Impact Review Ordinance for this rezoning, NOW, THEREFORE, BE IT

RESOLVED, that the application of Chapin 805, LLC for the rezoning from M2-General Manufacturing District to MS-Motor Services District of the property described in the attached legal description for the conversion of an existing warehouse building to a truck repair and truck parts sales facility be and the same is hereby approved subject to the following condition:

- 1. The applicant or owner must remove all unauthorized earthen fill recently placed along the banks of Ellicott Creek

, and BE IT FURTHER

RESOLVED, that any future additions to the development or site plan must be resubmitted to the Town Board to determine whether the addition is substantially in agreement with the intent of this rezoning and site plan approval, and BE IT FURTHER

RESOLVED, that the Zoning Map and Law of the Town of Cheektowaga be amended in accordance with the above.

LEGAL DESCRIPTION

All that tract or parcel of land situate in Town of Cheektowaga, County of Erie, and State of New York, All that tract or parcel of land situate in the Town of Cheektowaga, County of Erie and State of New York, being part of Lot No. 80 Township 11, Range 7 of the Holland Land Company's Survey, described as follows:

Beginning at the intersection of the westerly line of Lot No. 80, (Being also the easterly line of Rein Road) and the center line of Ellicott Creek: running thence northerly along said westerly Lot No. 80, a distance of three hundred eleven (311) feet more or less to a point distance six hundred twenty and seventy-seven hundredths (622.77) feet south of the southerly line of Pfohl Road, Being also the southwest corner of lands conveyed to Warren E Lang by deed recorded in Erie County Clerk's office in liber 7411 of Deeds page 383: running thence easterly parallel with said southerly line of Warren E Lang, two hundred and forty-seven (247) feet more or less to the center line of Ellicott Creek: running thence southerly and westerly along the center line of said creek, four hundred fifty-four and five tenths (454.5) feet to the point beginning.

RESULT:	ADOPTED [UNANIMOUS]
MOVER:	Diane Benczkowski, Councilmember
SECONDER:	Timothy J. Meyers, Councilmember
AYES:	Holtz, Rogowski, Kaminski, Wozniak, Benczkowski, Meyers



4. RESOLUTION 2014-410

Call for Public Hearing - Special Use Permit Accessory Drive Thru - 4243-4271 Genesee Street

Sponsored By: Councilmember Benczkowski, Councilmember Rogowski

WHEREAS, Benderson Development Co., LLC has made application and requested a special use permit and relief from the provisions of Section 260-48.2 of the Town of Cheektowaga Zoning law dealing with accessory drive-through windows, AND

WHEREAS, the applicant desires to construct a 9,800 s.f. retail building at 4243-4271 Genesee Street which will accommodate a 1,950 s.f. Starbucks Coffee shop with a proposed accessory drive through window, NOW, THEREFORE BE IT

RESOLVED, that a Public Hearing be held regarding said request under the provisions of the Zoning Law on August 4, 2014 at 6:45 P.M., at the Cheektowaga Town Hall, 3301 Broadway at the corner of Union Road.

◆

NOTICE OF PUBLIC HEARING

NOTICE IS HEREBY GIVEN that a Public Hearing will be held by the Town Board of the Town of Cheektowaga, Erie County, New York at the Town Hall in the said Town of Cheektowaga, 3301 Broadway corner of Union Road on the August 4, 2014 at 6:45 o'clock P.M., of said day for the purpose of considering the application of:

Benderson Development Company, LLC

for the issuance of a special use permit and variances from the accessory drive through window provisions of the Zoning Law of the Town of Cheektowaga for a new Starbucks Coffee Shop proposed at 4243-4271 Genesee Street.

All parties in interest and citizens will be given an opportunity to be heard in regard to such proposed application.

BY ORDER OF THE TOWN BOARD, Town of Cheektowaga, NY

Alice Magierski, TOWN CLERK

◆

ALL THAT TRACT OR PARCEL OF LAND, situate in the Town of Cheektowaga, County of Erie and State of New York, being part of Lot No. 5, Township 11, Range 7 of the Holland Land Company's Survey, and being more particularly bounded and described as follows:

COMMENCING at the intersection of the present south line of Genesee Street with the west line of lands conveyed to 4243 GS Associates, LLC by Deed recorded in the Erie County Clerk's Office in Liber 11083 of Deeds at page 3786;

Thence N74°55'15"E along the south line of Genesee Street a distance of 242.15 feet to the Point of Beginning;

Thence N74°55'15"E continuing along the south line of Genesee Street a distance of 227.91 feet to a point;

Thence N76°04'00"E continuing along the south line of Genesee Street a distance of 94.56 feet to a point;

Thence S10°37'15"E a distance of 65.08 feet to a point of curve;

Thence along a curve to the right having a radius of 594.06 feet, an arc distance of 78.83 feet to a point of tangency;

Thence S01°02'20"W a distance of 99.32 feet to a point of curve;

Thence along a curve to the right having a radius of 26.67 feet, an arc distance of 43.66 feet to a point of tangency;

Thence N89°06'14"W a distance of 242.75 feet to a point;

Thence N15°12'44"W a distance of 186.17 feet to the Point or Place of Beginning;

Containing 1.56 acres of land, more or less.

RESULT:	ADOPTED [UNANIMOUS]
MOVER:	Diane Benczkowski, Councilmember
SECONDER:	James P. Rogowski, Councilmember
AYES:	Holtz, Rogowski, Kaminski, Wozniak, Benczkowski, Meyers



5. RESOLUTION 2014-411

Call for Public Hearing to Amend Traffic Ordinance

Sponsored By: Councilmember Meyers, Councilmember Rogowski

BE IT RESOLVED, that a public hearing on proposed amendments to Chapter 235 (formerly Chapter 76) of the Code of the Town of Cheektowaga (Vehicle and Traffic) be held on August 4, 2014 at 6:45 P.M. at the Town Hall, 3301 Broadway, Cheektowaga, New York for the purpose of considering the advisability of adopting said amendments, and the Town Clerk is hereby directed to publish the following Notice of Hearing in the CHEEKTOWAGA BEE, said amendments being set forth in said Notice of Hearing.



NOTICE OF PUBLIC HEARING

PLEASE TAKE NOTICE that the Town Board of the Town of Cheektowaga, Erie County, New York will hold a public hearing at the Town Hall, 3301 Broadway in said Town of Cheektowaga on August 4, 2014 at 6:45 P.M. to consider the advisability of adopting amendments to Chapter 235 of the Code of the Town of Cheektowaga (Vehicle and Traffic); said proposed amendments being as follows:

ARTICLE V. Schedules, Section 235-49, Schedule X: Parking Prohibited in Designated Locations, shall be amended by deleting therefrom the following:

In accordance with the provisions of §235-34, no person shall park a vehicle at any time upon any of the following described streets or parts of streets:

REO AVENUE - East side: from the north curb line of Walden Avenue to a point 25 feet north

ARTICLE V. Schedules, Section 235-49, Schedule X: Parking Prohibited in Designated Locations, shall be amended by adding thereto the following:

In accordance with the provisions of § 235-34, no person shall park a vehicle at any time upon any of the following described streets or parts of streets:

REO AVENUE - East side: from the north curb line of Walden Avenue to a point 50 feet north

FAIRELM LANE - North side: between a point 114 feet east of the east curb line of Constance Lane to a point 156 feet east of the east curb line of Constance Lane

ARTICLE V. Schedules, Section 235-51, Schedule XII: Stopping Prohibited in Designated Locations, shall be amended by adding thereto the following:

ALLIED DRIVE - West side: from the south curb line of Broadway southerly around the cul-de-sac to the north curb line of the loading dock driveway of 125 Allied Drive.

BY ORDER OF THE TOWN BOARD OF THE TOWN OF CHEEKTOWAGA, ERIE COUNTY, NEW YORK.

Dated: July 21, 2014

ALICE MAGIERSKI, Town Clerk

RESULT:	ADOPTED [UNANIMOUS]
MOVER:	Timothy J. Meyers, Councilmember
SECONDER:	James P. Rogowski, Councilmember
AYES:	Holtz, Rogowski, Kaminski, Wozniak, Benczkowski, Meyers



6. RESOLUTION 2014-412

Notice to Bidders - Equipment & Operators for the Cleaning, Televising and Grouting of Various Sanitary Sewers (Bid #2014-27)

Sponsored By: Councilmember Meyers, Supervisor Holtz

WHEREAS, it is in order that bids be advertised for the furnishing of Equipment & Operators for the Cleaning, Televising and Grouting of Various Sanitary Sewers in the Town of Cheektowaga, AND

WHEREAS, the Engineering Department has completed preparation of bid specifications, NOW, THEREFORE, BE IT

RESOLVED, that the Town Clerk be directed to publish a Notice to Bidders for the furnishing of Equipment & Operators for the Cleaning, Televising and Grouting of Various Sanitary Sewers in the Town of Cheektowaga (Bid 2014-27), said notice to be published in the CHEEKTOWAGA BEE and, BE IT FURTHER

RESOLVED, that sealed bids will be received on the 6th day of August, 2014 at 11:00 am at a public bid opening to be held in the Council Chambers in the Cheektowaga Town Hall.

NOTICE TO BIDDERS

Sealed proposals will be received and considered by the Town Board of the Town of Cheektowaga on August 6, 2014 at 11:00 am at the Town Hall, corner of Broadway and Union Roads, for the furnishing of Equipment and Operators for the Cleaning, Televising and Grouting of Various Sanitary Sewers in the Town of Cheektowaga for the balance of the 2014 calendar year.

Information for bidders and specifications may be obtained from the Town Clerk in said Town Hall.

Proposals shall be submitted in a sealed envelope plainly marked on the outside "Bid for Furnishing Equipment and Operators for the Cleaning, Televising, and Grouting of Various Sanitary Sewers (Bid 2014-27) and be submitted to the Town Clerk prior to bid opening.

No bidder may withdraw his bid within forty-five (45) days after the actual date of the opening thereof.

The Town Board reserves the right to consider informal any bid not prepared and submitted in accordance with the provisions of the specifications and contract documents, and may waive any informalities, make an award to other than the low bidder, should it be in the best interest of the Town, or reject any or all bids.

Each proposal must be accompanied by a certified check for a sum equal to five percent (5%) of the amount of the bid, payable to the Town of Cheektowaga, New York, or bond with sufficient sureties to be approved by the attorney for the Town of Cheektowaga, New York.

The successful bidder will be required to furnish a Performance Bond acceptable to the Owner in an amount equal to the contract award.

By Order of the Town Board of the Town of Cheektowaga, Erie County, New York.

Alice Magierski
Town Clerk

DATED: July 21, 2014

RESULT:	ADOPTED [UNANIMOUS]
MOVER:	Timothy J. Meyers, Councilmember
SECONDER:	Mary Holtz, Supervisor
AYES:	Holtz, Rogowski, Kaminski, Wozniak, Benczkowski, Meyers



7. RESOLUTION 2014-413

Notice to Bidders - Equipment & Operators for the Installation of Cured-in-Place Sanitary Sewer Point Repairs (Bid #2014-30)

Sponsored By: Councilmember Meyers, Supervisor Holtz

WHEREAS, it is in order that bids be advertised for the furnishing of Equipment & Operators for the Installation of Cured-in-Place Sanitary Sewer Point Repairs in the Town of Cheektowaga for the balance of the 2014 calendar year, AND

WHEREAS, the Engineering Department has completed preparation of bid specifications, NOW, THEREFORE, BE IT

RESOLVED, that the Town Clerk be directed to publish a notice to Bidders for the furnishing of Equipment & Operators for the Installation of Cured-in-Place Sanitary Sewer Point Repairs in the Town of Cheektowaga (Bid 2014-30), said notice to be published in the CHEEKTOWAGA BEE, AND, BE IT FURTHER

RESOLVED, that sealed bids will be received on the 6th day of August, 2014 at 11:00 am at a public bid opening to be held in the Council Chambers in the Cheektowaga Town Hall.

NOTICE TO BIDDERS

Sealed proposals will be received and considered by the Town Board of the Town of Cheektowaga on August 6, 2014 at 11:00 am at the Town Hall, corner of Broadway and Union Roads, for the furnishing of Equipment and Operators for the Installation of Cured-in-Place Sanitary Sewer Point Repairs in the Town of Cheektowaga for the balance of the 2014 calendar year.

Information for bidders and specifications may be obtained from the Town Clerk in said Town Hall.

Proposals shall be submitted in a sealed envelope plainly marked on the outside "Bid for Furnishing of Equipment and Operators for the Installation of Cured-in-Place Sanitary Sewer Point Repairs" (Bid 2014-30) and be submitted to the Town Clerk prior to bid opening.

No bidder may withdraw his bid within forty-five (45) days after the actual date of the opening thereof.

The Town Board reserves the right to consider informal any bid not prepared and submitted in accordance with the provisions of the specifications and contract documents, and may waive any informalities, make an award to other than the low bidder, should it be in the best interest of the Town, or reject any or all bids.

Each proposal must be accompanied by a certified check for a sum equal to five percent (5%) of the amount of the bid, payable to the Town of Cheektowaga, New York, or bond with sufficient sureties to be approved by the attorney for the Town of Cheektowaga, New York.

The successful bidder will be required to furnish a Performance Bond acceptable to the Owner in an amount equal to the contract award.

By Order of the Town Board of the Town of Cheektowaga, Erie County, New York.

Alice Magierski
Town Clerk

DATED: July 21, 2014

RESULT:	ADOPTED [UNANIMOUS]
MOVER:	Timothy J. Meyers, Councilmember
SECONDER:	Mary Holtz, Supervisor
AYES:	Holtz, Rogowski, Kaminski, Wozniak, Benczkowski, Meyers



8. RESOLUTION 2014-414

Notice to Bidders - Demolition with Asbestos Abatement of 42 Avery Place (BID 2014-31 LAW)

Sponsored By: Supervisor Holtz, Councilmember Benczkowski

WHEREAS, it is in order that bids be advertised for the demolition and asbestos abatement of structures located at 42 Avery Place, Cheektowaga, New York; and

WHEREAS, specifications for same have been prepared by the Town Attorney's Office with the assistance of Nussbaumer & Clarke, Inc.; NOW, THEREFORE, BE IT

RESOLVED, that the Town Clerk be and hereby is directed to publish a Notice to Bidders (BID 2014-31 LAW) for the demolition and asbestos abatement of structures located at 42 Avery Place, said notice to be published in the CHEEKTOWAGA BEE, and BE IT FURTHER

RESOLVED, that sealed bids will be received and opened by the Town Clerk at a public bid opening to be held in the Council Chambers at the Cheektowaga Town Hall on Wednesday, July 30, 2014 at 11:00 A.M.



NOTICE TO BIDDERS

Sealed proposals will be received by the Town Clerk of the Town of Cheektowaga on Wednesday, July 30, 2014, at 11:00 A.M. at the Cheektowaga Town Hall, 3301 Broadway, Cheektowaga, New York, for the demolition and asbestos abatement of structures located at 42 Avery Place (BID 2014-31 LAW), situate in the Town of Cheektowaga, New York.

Information for bidders and specifications may be obtained from the Town Clerk at her office in said Town.

The Town Board reserves the right to consider informal any bid not prepared and submitted in accordance with the provisions of the specification and contract documents, and may waive any informalities, make an award to other than the low bidder, or reject any or all bids should it be in the best interest of the Town.

BY ORDER OF THE TOWN BOARD OF THE TOWN OF CHEEKTOWAGA, ERIE COUNTY, NEW YORK.

Alice Magierski, Town Clerk

Dated: 21 July 2014

RESULT: **ADOPTED [UNANIMOUS]**
MOVER: Mary Holtz, Supervisor
SECONDER: Diane Benczkowski, Councilmember
AYES: Holtz, Rogowski, Kaminski, Wozniak, Benczkowski, Meyers



9. RESOLUTION 2014-415

Award of Bid - Rein Road Bridge Rehabilitation Project (Bid #2014-28)

Sponsored By: Supervisor Holtz, Councilmember Kaminski

WHEREAS, a Notice to Bidders was duly published for the receipt of bids for the Rehabilitation of the Rein Road Bridge Spanning Ellicott Creek, PIN 5758.38, BIN 2212970, which bids were duly received and opened on July 2, 2014 by the Town Clerk, AND

WHEREAS, said bids were referred to the Engineering Department and the project engineering consulting firm of Greenman Pedersen, Inc. for analysis, tabulation and report, which analysis, tabulation and report is contained in a letter from the Town Engineer dated July 16, 2014, AND

WHEREAS, the Town Engineer and Greenman Pedersen, Inc. have recommended that the bid be awarded to Hunting Valley Construction, Inc. based on their submission of the lowest bid meeting the requirements of the specifications, NOW, THEREFORE, BE IT

RESOLVED, that the bid for the Rehabilitation of the Rein Road Bridge Spanning Ellicott Creek be and hereby is awarded to Hunting Valley Construction, Inc., 825 Rein Road, Cheektowaga, New York 14225 for the base bid price of \$810,782.90, being the lowest bid meeting the requirements of the specifications, AND, BE IT FURTHER

RESOLVED, that the Supervisor be and hereby is directed and authorized to sign any and all agreements for the aforesaid contract on behalf of this Town Board, AND, BE IT FURTHER

RESOLVED, that funding for said bridge rehabilitation project shall be chargeable to Account No. 500-1440-2050-5030 with said project being eligible for 80% federal funding reimbursement under the Federal Highway Bridge Rehabilitation and Replacement Program and State Marchiselli Aid Reimbursement in accordance with Supplemental Agreement No. 2 between the Town of Cheektowaga and the New York State Department of Transportation.

RESULT:	ADOPTED [UNANIMOUS]
MOVER:	Mary Holtz, Supervisor
SECONDER:	Gerald Kaminski, Councilmember
AYES:	Holtz, Rogowski, Kaminski, Wozniak, Benczkowski, Meyers



10. RESOLUTION 2014-416

Renew Flood Insurance Coverage for Anna Reinstein Library

Sponsored By: Supervisor Holtz, Councilmember Kaminski

WHEREAS, the Town's Flood Insurance Coverage for the Anna Reinstein Library at 2580 Harlem Road expired on July 19, 2014, AND

WHEREAS, Holfoth Risk Management, the Town's insurance consultant, solicited a renewal quote from American Bankers Trust Company of Florida (guaranteed through the Federal Flood Program) for this flood insurance coverage, and has recommended that we renew said insurance through Travelers Insurance Company, NOW, THEREFORE, BE IT

RESOLVED, that this Town Board hereby awards the flood insurance for the Anna Reinstein Library with coverage to Travelers Insurance Company in the amount of \$500,000.00 (\$100,000 for contents) for an annual premium of \$3,208.00 and, BE IT FURTHER

RESOLVED, that moneys for said insurance shall be appropriated from budget line item number 101.1710.4101 and, BE IT FURTHER

RESOLVED, that the Supervisor be and hereby is authorized and directed to execute any and all documents to effectuate this flood insurance coverage.

RESULT:	ADOPTED [UNANIMOUS]
MOVER:	Mary Holtz, Supervisor
SECONDER:	Gerald Kaminski, Councilmember
AYES:	Holtz, Rogowski, Kaminski, Wozniak, Benczkowski, Meyers



11. RESOLUTION 2014-417

Authorize Supervisor to Execute Supplemental Agreement No. 2 with NYSDOT for the Rein Road Bridge Rehabilitation Project

Sponsored By: Supervisor Holtz, Councilmember Kaminski

WHEREAS, a project for the Rehabilitation of the Rein Road Bridge over Ellicott Creek, BIN 2212970 in the Town of Cheektowaga, Erie County, PIN 5758.38 (the "Project") is eligible for funding under Title 23 U.S. Code, as amended, that calls for the apportionment of the costs of such program to be borne at the ratio of 80% federal funds and 20% non-federal funds, AND

WHEREAS, the Town of Cheektowaga desires to advance the Project by making a commitment of 100% of the non-federal share of the costs of the Preliminary Engineering (Design I-VI), Right-of-Way (Incidentals & Acquisition) and Construction & Construction Inspection phases of the Project, PIN 5758.38, NOW, THEREFORE, BE IT

RESOLVED, that the Town Board of the Town of Cheektowaga hereby approves the above subject project and hereby authorizes the Town of Cheektowaga to pay in the first instance 100% of the federal and non-federal shares of the cost of the Preliminary Engineering (Design I-VI), Right-of-Way (Incidentals & Acquisition) and Construction & Construction Inspection phases of the Project or portions thereof and, BE IT FURTHER

RESOLVED, that the sum of \$190,420 is hereby appropriated from Account No. 500-1440-2050-5030 in addition to \$219,195 previously appropriated by Town Resolution Nos. 2010-579 and 2013-391 adopted on October 4, 2010 and July 30, 2013, respectively, and made available to cover the cost of participation in the Preliminary Engineering (Design I-VI), Right-of-Way (Incidentals & Acquisition) and Construction & Construction Inspection phases of the Project and, BE IT FURTHER

RESOLVED, that in the event the amount required to pay, in the first instance 100% of the federal and non-federal shares of the cost of the project's Preliminary Engineering (Design I-VI), Right-of-Way (Incidentals & Acquisition) and Construction & Construction Inspection phases exceeds the amount appropriated, \$409,615 and/or 100% of the full federal and non-federal shares of the cost of the project's Preliminary Engineering (Design I-VI), Right-of-Way (Incidentals & Acquisition) and Construction & Construction Inspection phases exceeds \$1,171,295, the project's current total cost, the Town of Cheektowaga shall convene a meeting as soon as possible to appropriate said excess amount immediately upon the notification by the New York State Department of Transportation thereof and, BE IT FURTHER

RESOLVED, that the Supervisor of the Town of Cheektowaga is hereby authorized to execute all necessary Agreements, certifications or reimbursement requests for Federal Aid and/or Marchiselli Aid on behalf of the Town of Cheektowaga with the New York State Department of Transportation in connection with the advancement or approval of the Project and providing for the administration of the Project and the municipality's first instance funding of project costs and permanent funding of the local share of Federal Aid and State Aid eligible Project costs and all Project costs within appropriations therefore that are not so eligible and, IT IS FURTHER

RESOLVED, that a certified copy of this Resolution be filed with the New York State Commissioner of Transportation by attaching it to any necessary Agreement in connection with the Project and, BE IT FURTHER

RESOLVED, this Resolution shall take effect immediately.

RESULT:	ADOPTED [UNANIMOUS]
MOVER:	Mary Holtz, Supervisor
SECONDER:	Gerald Kaminski, Councilmember
AYES:	Holtz, Rogowski, Kaminski, Wozniak, Benczkowski, Meyers



12. RESOLUTION 2014-418

Authorize Supervisor to Sign Supplemental Agreement No. 2 with Greenman Pedersen, Inc. for the Rehabilitation of the Rein Road Bridge

Sponsored By: Supervisor Holtz, Councilmember Kaminski

WHEREAS, the Town of Cheektowaga was awarded a grant for Federal Highway Bridge Rehabilitation and Replacement (HBRR) Funds to rehabilitate the Rein Road Bridge over Ellicott Creek, PIN 5758.38, which grant is required to be administered in accordance with New York State Department of Transportation guidelines and procedures for Locally Administered Federal Aid Projects, AND

WHEREAS, by resolution dated October 4, 2010 this Town Board authorized the Town Supervisor to execute a Federal Aid Local Project Agreement for the Preliminary Engineering (Design I-VI) phase of said project with the apportionment cost of this project to be at the ratio of 80% federal funds and 20% non-federal funds, AND

WHEREAS, under the Procedures for a Locally Administered Federal Aid Project the Town, by resolution dated September 19, 2011, engaged the firm of Abate Associates, Engineers and Surveyors P.C., which firm following a merger is now known as Greenman Pedersen, Inc., for preliminary and final design services, Phases I-VI, AND

WHEREAS, by resolution dated February 20, 2013 this Town Board authorized the Town Supervisor to execute Supplemental Agreement No. 1 with Greenman Pedersen, Inc. for the inclusion of right-of-way tasks for said project, AND

WHEREAS, by resolution dated July 30, 2013 this Town Board authorized the Town Supervisor to execute Federal Aid Local Project Agreement, Supplemental Agreement No. 1 with NYSDOT to provide for a Right-of-Way Incidentals and Acquisition phase of the project, AND

WHEREAS, by resolution dated July 21, 2014 this Town Board authorized the Town Supervisor to execute a Federal Aid Local Project Agreement, Supplemental Agreement No. 2 with NYSDOT in accordance with Procedures for Locally Administered Federal Aid Projects, which provides for and details the Federal Funding Share and State Marchiselli Program Aid funding share for the Construction and Construction Inspection phase of the Project, AND

WHEREAS, there is a need to amend the agreement with Greenman Pedersen, Inc. to include Construction Phase Services and Construction Inspection Services for the Rein Road Bridge Rehabilitation Project, NOW, THEREFORE, BE IT

RESOLVED, that the proposal of Greenman Pederson, Inc. dated May 19, 2014, being a Supplemental Agreement No. 2 for the provision of Construction Phase Services in an amount not to exceed \$141,275.67 be and hereby is accepted and approved and, BE IT FURTHER

RESOLVED, that the Supervisor, on behalf of this Town Board, is directed and authorized to sign said Supplemental Agreement No. 2 with Greenman Pedersen, Inc., and, BE IT FURTHER

RESOLVED, that the cost of said Supplemental Agreement No. 2 Construction Phase and Construction Inspection Services shall be chargeable to Account #500-1440-2050-5030.

RESULT:	ADOPTED [UNANIMOUS]
MOVER:	Mary Holtz, Supervisor
SECONDER:	Gerald Kaminski, Councilmember
AYES:	Holtz, Rogowski, Kaminski, Wozniak, Benczkowski, Meyers



13. RESOLUTION 2014-419

Authorize Supervisor to Execute Agreement for Meals on Wheels Program

Sponsored By: Supervisor Holtz, Councilmember Kaminski

WHEREAS, for the past several years, the Town of Cheektowaga Senior Citizens Center has acted as a site for the Meals on Wheels program operated by Meals on Wheels for Western New York, Inc., AND

WHEREAS, this program allows senior citizens who are house bound to have nutritious meals delivered to them, AND

WHEREAS, Meals on Wheels of Western New York, Inc. has again requested the use of the Town's Senior Citizens Center for its Meals on Wheels program, AND

WHEREAS, this Board supports this program, NOW, THEREFORE, BE IT

RESOLVED, that the Supervisor be and hereby is authorized and directed to execute an agreement with Meals on Wheels of Western New York for the use of the Town Senior Citizens Center, subject to approval of the form thereof by the Town Attorney.

RESULT:	ADOPTED [UNANIMOUS]
MOVER:	Mary Holtz, Supervisor
SECONDER:	Gerald Kaminski, Councilmember
AYES:	Holtz, Rogowski, Kaminski, Wozniak, Benczkowski, Meyers



14. RESOLUTION 2014-420

Authorize Supervisor to Execute Application for Operation IMPACT Tools Grant

Sponsored By: Councilmember Benczkowski, Councilmember Kaminski

WHEREAS, the Operation IMPACT Tools Grant is sponsored by the Department of Criminal Justice Services to reduce UCR Part 1 Crimes, by developing and implementing problem-solving strategies, AND

WHEREAS, Grantmakers Advantage, Inc. filed a grant application on behalf of the Town of Cheektowaga Police Department to secure \$50,000 to address the reduction of Part 1 crimes, AND

WHEREAS, the Town was awarded a \$50,000 grant through Operation IMPACT Tools;
NOW, THEREFORE, BE IT

RESOLVED, that the Supervisor be and hereby is authorized and directed to execute any and all documents pertaining to the application for and acquisition of said funding, including all contractual and reporting documents.

RESULT:	ADOPTED [UNANIMOUS]
MOVER:	Diane Benczkowski, Councilmember
SECONDER:	Gerald Kaminski, Councilmember
AYES:	Holtz, Rogowski, Kaminski, Wozniak, Benczkowski, Meyers



15. RESOLUTION 2014-421

Authorize Supervisor to Execute Grant Application

Sponsored By: Councilmember Benczkowski, Councilmember Kaminski

WHEREAS, the New York State Division of Homeland Security and Emergency Services Office of Counter Terrorism has grant monies available through the FY2014 Technical Rescue and Urban Search and Rescue (USAR) Grant Program, AND

WHEREAS, the Cheektowaga Police Department seeks funding to advance the capabilities of their tactical team, NOW, THEREFORE, BE IT

RESOLVED, that KHEOPS, the Town's grant consultants, be authorized and directed to complete the necessary application, forms, etc. to be submitted to the New York State Division of Homeland Security and Emergency Services for the purpose of securing this grant, and BE IT FURTHER

RESOLVED, that the Supervisor and Chief of Police be and hereby are authorized and directed to execute all documents pertaining to the application and acquisition of said funding.

RESULT:	ADOPTED [UNANIMOUS]
MOVER:	Diane Benczkowski, Councilmember
SECONDER:	Gerald Kaminski, Councilmember
AYES:	Holtz, Rogowski, Kaminski, Wozniak, Benczkowski, Meyers



16. RESOLUTION 2014-422

Appointment of Coordinator of Employee Relations

Sponsored By: Holtz, Kaminski, Rogowski, Wozniak, Benczkowski, Meyers

WHEREAS, a vacancy currently exists in the position of Coordinator of Employee Relations, AND

WHEREAS, such position was duly advertised, AND

WHEREAS, this Town Board reviewed applications and conducted interviews for this position, AND

WHEREAS, Karen Marchese applied for this position and meets all of the requirements for and is highly qualified for this position, NOW, THEREFORE, BE IT

RESOLVED, that, pursuant to paragraph 7 of the Residency Law of the Town of Cheektowaga, this Town Board has determined that, by reason of special skills, aptitude and expertise, an appropriate appointment cannot be made to fill the position of Coordinator of Employee Relations with a domiciliary in the Town of Cheektowaga, and BE IT FURTHER

RESOLVED, the Karen Marchese of Batavia, New York be and hereby is appointed to the position of Coordinator of Employee Relations, effective August 4, 2014, at an annual salary established for said position, and BE IT FURTHER

RESOLVED, that, in compliance with the Residency Law of the Town of Cheektowaga, Karen Marchese is hereby ordered to obtain residency within the Town of Cheektowaga within six (6) months from the date of this resolution.

RESULT:	ADOPTED [UNANIMOUS]
MOVER:	Mary Holtz, Supervisor
SECONDER:	Gerald Kaminski, Councilmember
AYES:	Holtz, Rogowski, Kaminski, Wozniak, Benczkowski, Meyers



17. RESOLUTION 2014-423

Appointment of Police Officers (Competitive/Permanent) Dennis M. Frajdofer, Jr., Eric D. Derby, Matthew R. Maggio

Sponsored By: Councilmember Benczkowski, Councilmember Kaminski

WHEREAS, three (3) vacancies exist in the position of Police Officer in the Town of Cheektowaga, AND

WHEREAS, the civil service list for said title has been canvassed and candidates have been interviewed; NOW, THEREFORE, BE IT

RESOLVED, that the following be and hereby are appointed to the position of Police Officer at a salary in accordance with the collective bargaining agreement between the Town of Cheektowaga and the Town of Cheektowaga Police Club:

1. Dennis M. Frajdofer, Jr. of Cheektowaga, New York
2. Eric D. Derby of Cheektowaga, New York
3. Matthew R. Maggio of Depew, New York; AND, BE IT FURTHER

RESOLVED, that these officers' seniority be based on the order of their appointment as enumerated above and, BE IT FURTHER

RESOLVED, that said appointments shall become effective July 31, 2014, and are subject to verification of compliance with the Residency Law of the Town of Cheektowaga.

RESULT:	ADOPTED [UNANIMOUS]
MOVER:	Diane Benczkowski, Councilmember
SECONDER:	Gerald Kaminski, Councilmember
AYES:	Holtz, Rogowski, Kaminski, Wozniak, Benczkowski, Meyers



18. RESOLUTION 2014-424

Appointment of Laborer (Labor/Permanent) Highway Department/Peter D. Gerlach

Sponsored By: Councilmember Rogowski, Supervisor Holtz

WHEREAS, a vacancy exists in the title of Laborer in the Highway Department; AND

WHEREAS, notice of such vacancy has been posted in accordance with the provisions of the Town's collective bargaining agreement with the Town of Cheektowaga Employees Association; AND

WHEREAS, Peter D. Gerlach, currently employed as a Motor Equipment Operator - B in the Sanitation Department, bid on said vacancy and meets the necessary qualifications for appointment; NOW, THEREFORE, BE IT

RESOLVED, that Peter D. Gerlach of Cheektowaga, New York, be and hereby is appointed to the position of Laborer in the Highway Department in accordance with the terms and conditions of the Town's collective bargaining agreement with the Town of Cheektowaga Employees Association effective July 21, 2014.

RESULT:	ADOPTED [UNANIMOUS]
MOVER:	James P. Rogowski, Councilmember
SECONDER:	Mary Holtz, Supervisor
AYES:	Holtz, Rogowski, Kaminski, Wozniak, Benczkowski, Meyers



19. RESOLUTION 2014-425

Appointment of Motor Equipment Operator - B (Non-Competitive/Permanent) Sanitation Department/Scott R. Fullington

Sponsored By: Councilmember Kaminski, Supervisor Holtz

WHEREAS, a vacancy exists in the title of Motor Equipment Operator - B in the Sanitation Department; AND

WHEREAS, Scott R. Fullington, currently employed as a Laborer in the Highway Department, will exercise his right to super-seniority bidding rights; AND

WHEREAS, Scott R. Fullington meets the qualifications for appointment to the title of Motor Equipment Operator - B; NOW, THEREFORE, BE IT

RESOLVED, that Scott R. Fullington of Cheektowaga, New York, be and hereby is appointed to the position of Motor Equipment Operator - B in the Sanitation Department in accordance with the terms and conditions of the Town's collective bargaining agreement with the Town of Cheektowaga Employees Association effective July 21, 2014.

RESULT:	ADOPTED [UNANIMOUS]
MOVER:	Gerald Kaminski, Councilmember
SECONDER:	Mary Holtz, Supervisor
AYES:	Holtz, Rogowski, Kaminski, Wozniak, Benczkowski, Meyers



20. RESOLUTION 2014-426

Appointment of Park Maintenance Worker I (Labor/Permanent) Facilities Department (Parks Division)/William R. Haderer

Sponsored By: Councilmember Rogowski, Councilmember Kaminski

WHEREAS, a vacancy exists in the title of Park Maintenance Worker I in the Facilities Department (Parks Division); AND

WHEREAS, notice of said vacancy has been posted in accordance with the provisions of the Town's collective bargaining agreement with the Town of Cheektowaga Employees Association; AND

WHEREAS, no full-time bargaining unit bid on said vacancy; AND

WHEREAS, William R. Haderer of Cheektowaga, New York, currently employed as a temporary Park Maintenance Worker I, applied for said position and meets the necessary qualifications for appointment; NOW, THEREFORE, BE IT

RESOLVED, that William R. Haderer of Cheektowaga, New York, be and hereby is appointed to the position of Park Maintenance Worker I in the Facilities Department (Parks Division) in accordance with the terms and conditions of the Town's collective bargaining agreement with the Town of Cheektowaga Employees Association effective July 22, 2014.

RESULT:	ADOPTED [UNANIMOUS]
MOVER:	James P. Rogowski, Councilmember
SECONDER:	Gerald Kaminski, Councilmember
AYES:	Holtz, Rogowski, Kaminski, Wozniak, Benczkowski, Meyers



21. RESOLUTION 2014-427

Appointment to Cheektowaga Economic Development Corporation Directors

Sponsored By: Councilmember Benczkowski, Supervisor Holtz

WHEREAS, the Town Board of the Town of Cheektowaga previously created the Cheektowaga Economic Development Corporation for the purpose of assisting and encouraging economic development within the Town, AND

WHEREAS, by Resolution dated February 7, 1983 this Town Board approved the By-Laws of the Cheektowaga Economic Development Corporation which provide that the Directors of the Cheektowaga Economic Development Corporation be appointed by resolution of the Cheektowaga Town Board, AND

WHEREAS, the Cheektowaga Economic Development Corporation Board of Directors has unanimously recommended the appointment of the individual listed below to the Board of Directors of the Cheektowaga Economic Development Corporation for a term of two years, NOW, THEREFORE, BE IT

RESOLVED, that the following individual is hereby appointed to the Board of Directors of the Cheektowaga Economic Development Corporation, effective immediately for a term of two years, said term expiring at the time of reappointment to said Board of Directors positions in 2016, but no later than June 30, 2016:

Jeffrey C. Mendola

RESULT:	ADOPTED [UNANIMOUS]
MOVER:	Diane Benczkowski, Councilmember
SECONDER:	Mary Holtz, Supervisor
AYES:	Holtz, Rogowski, Kaminski, Wozniak, Benczkowski, Meyers



22. RESOLUTION 2014-428

Appointment of Member of Traffic Safety Commission

Sponsored By: Councilmember Meyers, Councilmember Rogowski

WHEREAS, there is a vacancy in the position of member of the Cheektowaga Traffic Safety Commission, AND

WHEREAS, Joseph Gasiewicz has expressed an interest in serving on the Traffic Safety Commission, AND

WHEREAS, the Traffic Safety Commission has recommended that Joseph Gasiewicz be appointed to the Traffic Safety Commission, NOW, THEREFORE, BE IT

RESOLVED, that Joseph Gasiewicz, Depew, New York, be and hereby is appointed as member of the Traffic Safety Commission, effective immediately and terminating on December 31, 2015.

RESULT:	ADOPTED [UNANIMOUS]
MOVER:	Timothy J. Meyers, Councilmember
SECONDER:	James P. Rogowski, Councilmember
AYES:	Holtz, Rogowski, Kaminski, Wozniak, Benczkowski, Meyers



23. RESOLUTION 2014-429

Youth & Recreation Terminations

Sponsored By: Councilmember Wozniak, Councilmember Rogowski

BE IT RESOLVED that the individuals listed below be and hereby are terminated in the Department of Youth & Recreational Services effective as indicated:

Lillith Boyd-Gamel	Never worked	14225
Steven Gasiorek	8/30/13	14206
Tracey Marlinski	5/10/14	14227
Susan Mayle	3/14/14	14225
Megan McIntosh	Never worked	14225
Alexis Wayne	8/30/13	14227

Motion by Councilmember Rogowski; Seconded by Councilmember Benczkowski to Waive the Reading of Names for the following three (3) resolutions: 2014-429; 2014-430 and 2014-431. Motion Carried.

RESULT: ADOPTED [UNANIMOUS]
MOVER: Angela M. Wozniak, Councilmember
SECONDER: James P. Rogowski, Councilmember
AYES: Holtz, Rogowski, Kaminski, Wozniak, Benczkowski, Meyers



24. RESOLUTION 2014-430

Youth & Recreation Hire/Transfers

Sponsored By: Councilmember Wozniak, Councilmember Rogowski

WHEREAS the Youth & Recreational Services Department is in need of replacing a Special Needs 1 to 1 Camp Counselor, AND

WHEREAS, Chapter 25-7 of the Town Code allows for the TOWN to relax residency restrictions for any position of employment requiring special skills, aptitude and expertise, AND

WHEREAS, the above position require special skills, aptitude and expertise as per code 25-7, NOW, THEREFORE, BE IT

RESOLVED, that, based on the above, this Town Board hereby exempts the following position and individual from Town residency requirement; and hereby appoints him to the following position, effective immediately:

Recreation Attendant (1:1) - 7140.1632 - \$8.00 - Seasonal - Retro to 7/7/14
Benjamin Kean 14075

BE IT FURTHER RESOLVED, that the following individuals be transferred as indicated below:

Recreation Aide to Recreation Attendant - 7310.1801 - \$8.00 - Regular Part-Time
Jessica Gaffney

Recreation Aide 7310.1801(Alexander Day Camp) to 7140.1632(Dartwood Day Camp) - \$8.00 - Part-Time
Alexe Wodowski

RESULT:	ADOPTED [UNANIMOUS]
MOVER:	Angela M. Wozniak, Councilmember
SECONDER:	James P. Rogowski, Councilmember
AYES:	Holtz, Rogowski, Kaminski, Wozniak, Benczkowski, Meyers



25. RESOLUTION 2014-431

Hiring/Termination of Part-Time/Seasonal Employees

Sponsored By: Councilmember Kaminski, Supervisor Holtz

BE IT RESOLVED, that the following individuals be and hereby are hired as SEASONAL EMPLOYEES, not to exceed five (5) months in a calendar year, in the various departments listed and in compliance with Civil Service Laws and Regulations as well as the provisions of the Town's collective bargaining agreement between the Town of Cheektowaga and the Town of Cheektowaga Employees Association:

SANITATION DEPARTMENT Laborer \$9.25/hour
Jeffrey T. Lewis, Cheektowaga, NY effective 7/1/14
Justin L. Struzik, Cheektowaga, NY effective 7/7/14

BE IT RESOLVED, that the following individuals be and hereby are hired as PART-TIME EMPLOYEES in the departments listed, not to exceed nineteen (19) hours on a weekly basis, in compliance with Civil Service Laws and Regulations as well as the provisions of the Town's collective bargaining agreement between the Town of Cheektowaga and the Town of Cheektowaga Employees Association:

POLICE DEPARTMENT Student Assistant \$8.00/hour effective 7/22/14
Hannah N. Benson, Cheektowaga, New York

POLICE DEPARTMENT Laborer \$10.50/hour effective 7/22/14
Jason C. Dorsey, Cheektowaga, New York

JUSTICE COURT Clerk \$9.00/hour effective 7/22/14
Marissa M. Floyd, Cheektowaga, New York

BE IT RESOLVED, that the following seasonal and/or part-time employees be and hereby are terminated as listed:

POLICE DEPARTMENT
Keileigh C. Pecyne effective 7/13/14
Miranda L. Turnbull effective 7/20/14
Matthew J. Hockwater effective 7/22/14

OFFICE OF THE TOWN ASSESSOR
Kristen M. Murphy effective 4/16/14
Kara N. Oxley effective 5/5/14

JUSTICE COURT
Lynn M. Imiola effective 7/3/14

BE IT RESOLVED, that the following be and hereby are amended as follows:

SANITATION DEPARTMENT Appointment of Seasonal Laborer \$9.25/hour effective 6/16/14
Amend name: Andrew P. Babcock to Andrew P. Babcock, Cheektowaga, New York

POLICE DEPARTMENT Termination
Anthony M. Theriault (include effective date of 10/18/13)

RESULT:	ADOPTED [UNANIMOUS]
MOVER:	Gerald Kaminski, Councilmember
SECONDER:	Mary Holtz, Supervisor
AYES:	Holtz, Rogowski, Kaminski, Wozniak, Benczkowski, Meyers

V. Suspension of Rules

Motion by Councilmember Rogowski; Seconded by Councilmember Meyers to Waive the Rules to Include the Following two (2) resolutions: 2014-432 and 2014-433. Motion Carried.
--



1. RESOLUTION 2014-432

Preparation of 5-Year Consolidated Plan

Sponsored By: Supervisor Holtz, Councilmember Benczkowski

PREPARATION OF 5-YEAR CONSOLIDATED PLAN

WHEREAS, the Towns of Amherst, Cheektowaga and Tonawanda have formed a consortium for the purpose of qualifying for federal HOME Investment Partnership funds, and

WHEREAS, consortia formed under the HOME Investment Partnership Act are required to prepare a new Consolidated Plan that analyzes housing and community development needs and establishes a plan for utilizing federal Community Development Block Grant and HOME funds to meet those needs during federal fiscal years 2015-2019, and

WHEREAS, the Community Development Departments from the three Towns have jointly requested proposals for the preparation of a new revised Consolidated Plan, and

WHEREAS, based on results from the Request for Proposal process, the Community Development Departments from the three towns recommend executing a contract in an amount not to exceed \$28,012 with Mullin & Lonergan Associates, Inc. to prepare the Consolidated Plan; and

WHEREAS, funds for the Analysis will be federal Community Development Block Grant (CDBG) monies available to each municipality with contributions shown as follows:

<input type="checkbox"/>	\$ 9,838	Town of Amherst
<input type="checkbox"/>	9,837	Town of Tonawanda
<input type="checkbox"/>	<u>9,837</u>	Town of Cheektowaga
	<u>\$28,012</u>	Total

NOW, THEREFORE, BE IT RESOLVED, that the Town Supervisor be and hereby is authorized to execute a joint contract between the three Towns and Mullen & Lonergan Associates, Inc., 800 Vinial Street, Suite B-414, Pittsburgh, PA 15212 for the preparation of a consortium Consolidated Plan for an amount not to exceed \$28,012, the cost to be shared equally by the Towns of Amherst, Cheektowaga and Tonawanda, for which the Town will pay an amount not to exceed \$9,837, and

BE IT FURTHER RESOLVED that the cost of said contract be paid from Community Development Block Grant funds.

RESULT:	ADOPTED [UNANIMOUS]
MOVER:	Mary Holtz, Supervisor
SECONDER:	Diane Benczkowski, Councilmember
AYES:	Holtz, Rogowski, Kaminski, Wozniak, Benczkowski, Meyers



2. RESOLUTION 2014-433

Special Event - Great Amazing Race-Family Fitness Activity

Sponsored By: Councilmember Rogowski, Councilmember Meyers

WHEREAS, by resolution dated May 1, 1995, this Town Board adopted a Special Events policy, which requires anyone wishing to hold a special event in the Town to file an application and supporting documentation, fees, etc. to the Town Clerk prior to the special event; and

WHEREAS, the "Great Amazing Race-Family Fitness Activity" has made application to hold its Family Fitness Activity to benefit Family Initiative and Pediatric Cancer Research on Sunday, August 3, 2014 at Stiglmeier Park from 2:00 p.m. until 6:00 p.m.; and

WHEREAS, this Board has reviewed the aforementioned application, which application has been approved by the Police Department, Highway Department, the Department of Youth and Recreation, and the Facilities Department, and has no objection to same; and

WHEREAS, due to the nature of the event, this Town Board hereby waives the following requirements:

1. Submittal of plan for sanitary facilities;
2. Submittal of site plan;
3. Requirement that application be made at least 60 days prior to the date of the special event;
4. Submittal of Security Plan;
5. Submittal of Fire Prevention/Emergency Services Plan;

NOW, THEREFORE, BE IT

RESOLVED, that this Town Board hereby approves the application of the "Great Amazing Race-Family Fitness Activity" for this event to be held on Sunday, August 3, 2014 in Stiglmeier Park.

RESULT:	ADOPTED [UNANIMOUS]
MOVER:	James P. Rogowski, Councilmember
SECONDER:	Timothy J. Meyers, Councilmember
AYES:	Holtz, Rogowski, Kaminski, Wozniak, Benczkowski, Meyers

VI. Communications

A. Departmental Communications

1. Minutes: Cheektowaga Public Library - June 25, 2014
2. Minutes: Cheektowaga Traffic Safety Commission - May 20, 2014
3. Minutes: Cheektowaga Traffic Safety Commission - June 17, 2014
4. Town of Cheektowaga Emergency Services Quarterly Report - April to June 2014

B. General Communications

1. 2014 Annual Report of the Department of Real Property Tax Services
2. Summons: Wendover Financial Services Corporation vs. Louise Reid, et al.
3. Notice of Claim: Antone D Page vs. Town of Cheektowaga
4. Notice of Petition: R & F Walden Avenue, LLC vs. Assessor, Board of Assessment Review and Town of Cheektowaga

VII. Comments

A. Supervisor's Comments

B. Councilmember's Comments

C. Public Comments

VIII. Adjournment

Motion by Supervisor Holtz; Seconded by Councilmember Kaminski to adjourn the meeting at 7:59 PM.

Alice Magierski, Town Clerk



Town of Cheektowaga

Regular Meeting

~ Minutes ~

3301 Broadway
Cheektowaga, NY 14227
<http://www.town.cheektowaga.ny.us>

Alice Magierski
716-686-3400

Monday, August 4, 2014

6:45 PM

Council Chambers

I. Call to Order

6:45 PM Meeting called to order on August 4, 2014 at Council Chambers, 3301 Broadway St, Cheektowaga, NY.

Attendee Name	Organization	Title	Status	Arrived
Mary Holtz	Town of Cheektowaga	Supervisor	Present	
James P. Rogowski	Town of Cheektowaga	Councilmember	Present	
Gerald Kaminski	Town of Cheektowaga	Councilmember	Present	
Angela M. Wozniak	Town of Cheektowaga	Councilmember	Absent	
Diane Benczkowski	Town of Cheektowaga	Councilmember	Present	
Timothy J. Meyers	Town of Cheektowaga	Councilmember	Present	

2. Additional Attendees

Patrick Bowen, Town Engineer
Robert Brandon, Zoning Board Chairman
Carla A. Kosmerl, Director of Community Development
Brian Krause, Director of Finance and Administration
Kevin Schenk, Town Attorney
Mark Wegner, Highway Superintendent

II. Public Comment Period

III. Public Hearings

1. Special Use Permit

Accessory Drive Thru - 4243-4271 Genesee Street

COMMENTS - Current Meeting:

This being the time and place advertised for a Public Hearing, the Supervisor directed the Town Clerk to present that such notice has been duly published and posted; upon the order of the Supervisor such proof was duly filed.

The Supervisor announced that the Town Board would hear all persons interested in the subject of the hearing. Comments were heard, after which the Supervisor declared the hearing closed, decision was reserved.

RESULT: CLOSED [UNANIMOUS]
MOVER: Diane Benczkowski, Councilmember
SECONDER: James P. Rogowski, Councilmember
AYES: Holtz, Rogowski, Kaminski, Benczkowski, Meyers
ABSENT: Angela M. Wozniak

2. Amend Traffic Ordinance

COMMENTS - Current Meeting:

This being the time and place advertised for a Public Hearing, the Supervisor directed the Town Clerk to present that such notice has been duly published and posted; upon the order of the Supervisor such proof was duly filed.

The Supervisor announced that the Town Board would hear all persons interested in the subject of the hearing. Comments were heard, after which the Supervisor declared the hearing closed, decision was reserved.

RESULT: CLOSED [UNANIMOUS]
MOVER: Timothy J. Meyers, Councilmember
SECONDER: James P. Rogowski, Councilmember
AYES: Holtz, Rogowski, Kaminski, Benczkowski, Meyers
ABSENT: Angela M. Wozniak

IV. Resolutions



1. RESOLUTION 2014-434

Transfer of Funds

Sponsored By: Supervisor Holtz, Councilmember Kaminski

BE IT RESOLVED, that the following transfer is hereby approved and made part hereof;

GENERAL

FROM:	100.1680.2204	Computer Hardware	\$25,000.00
	100.1410.4088	Travel	1,500.00
TO:	100.1680.4434	Software Maintenance	\$25,000.00
	100.1410.2201	Office Equipment	1,500.00

RESULT:	ADOPTED [UNANIMOUS]
MOVER:	Mary Holtz, Supervisor
SECONDER:	Gerald Kaminski, Councilmember
AYES:	Holtz, Rogowski, Kaminski, Benczkowski, Meyers
ABSENT:	Angela M. Wozniak



2. RESOLUTION 2014-435

Warrant

Sponsored By: Supervisor Holtz, Councilmember Kaminski

BE IT RESOLVED, that the following Vouchers & Warrants submitted to the Town of Cheektowaga prior to August 4, 2014 are hereby approved and made part hereof;

GENERAL FUND	\$2,745,797.03
RISK RETENTION FUND	814,149.66
NYS HOME PROGRAM	0.00
DEBT	44,043.75
HUD HOUSING REHABILITATION FUND	0.00
SPECIAL DISTRICTS FUND	1,039,734.92
HIGHWAY FUND	680,090.14
CAPITAL FUND	732,610.63
TRUST & AGENCY FUND	15,376.25
HUD CDBG FUND	97.78
PART TOWN FUND	123,432.39
NYS AFFORDABLE HOUSING	0.00
	<hr/>
	\$6,195,332.55

RESULT:	ADOPTED [UNANIMOUS]
MOVER:	Mary Holtz, Supervisor
SECONDER:	Gerald Kaminski, Councilmember
AYES:	Holtz, Rogowski, Kaminski, Benczkowski, Meyers
ABSENT:	Angela M. Wozniak



3. RESOLUTION 2014-436

Adopt Amendments to Vehicle and Traffic Law

Sponsored By: Councilmember Meyers, Councilmember Rogowski

WHEREAS, this Town Board held a public hearing on August 4, 2014 to consider the advisability of adopting proposed amendments to Chapter 235 of the Code of the Town of Cheektowaga (Vehicle and Traffic), said hearing being held in accordance with Notice thereof which was duly published as required by law, at which hearing an opportunity to be heard was afforded all persons interested in the subject thereof,

NOW, THEREFORE, BE IT RESOLVED, as follows:

Section 1.

That this Town Board determines it is in the public interest to adopt the following amendments to Chapter 235 of the Code of the Town of Cheektowaga, County of Erie and State of New York, and said amendments are herewith adopted and enacted:

ARTICLE V. Schedules, Section 235-49, Schedule X: Parking Prohibited in Designated Locations, shall be amended by deleting therefrom the following:

In accordance with the provisions of §235-34, no person shall park a vehicle at any time upon any of the following described streets or parts of streets:

REO AVENUE - East side: from the north curb line of Walden Avenue to a point 25 feet north

ARTICLE V. Schedules, Section 235-49, Schedule X: Parking Prohibited in Designated Locations, shall be amended by adding thereto the following:

In accordance with the provisions of § 235-34, no person shall park a vehicle at any time upon any of the following described streets or parts of streets:

REO AVENUE - East side: from the north curb line of Walden Avenue to a point 50 feet north

FAIRELM LANE - North side: between a point 114 feet east of the east curb line of Constance Lane to a point 156 feet east of the east curb line of Constance Lane

ARTICLE V. Schedules, Section 235-51, Schedule XII: Stopping Prohibited in Designated Locations, shall be amended by adding thereto the following:

ALLIED DRIVE - West side: from the south curb line of Broadway southerly around the cul-de-sac to the north curb line of the loading dock driveway of 125 Allied Drive.

Section 2. Time to Take Effect

These amendments shall take effect when properly posted within a reasonable time except those parts, if any, which are subject to approval under Section 1684 of the Vehicle and Traffic Law of the State of New York.

Any part or parts of these amendments which are subject to approval under Section 1684 of the Vehicle and Traffic Law of the State of New York shall take effect from and after the day on which approval in writing is received from the New York State Traffic Commission.

Section 3. Territorial Application

These amendments shall apply to all of the Town of Cheektowaga, Erie County, New York outside of the villages of Depew and Sloan.

Section 4. Publication

That these amendments to Chapter 235 (formerly Chapter 76) of the Code of the Town of Cheektowaga shall be entered into the minutes of the Town Board and shall be published in the CHEEKTOWAGA BEE, a newspaper published in this Town, and affidavits of such publication shall be filed with the Town Clerk and the Town Clerk shall likewise enter in the Ordinance Book a copy of said amendments specifying the date of adoption thereof.

RESULT:	ADOPTED [UNANIMOUS]
MOVER:	Timothy J. Meyers, Councilmember
SECONDER:	James P. Rogowski, Councilmember
AYES:	Holtz, Rogowski, Kaminski, Benczkowski, Meyers
ABSENT:	Angela M. Wozniak



4. RESOLUTION 2014-437

Adopt Video and Audio Recording Policy

Sponsored By: Supervisor Holtz, Councilmember Benczkowski

WHEREAS, the Town Board desires to adopt a formal policy to address retention and storage issues associated with video and audio records/recordings, and

WHEREAS, the Municipal Records Manager created the video and audio recording policy, and

WHEREAS, periodically, this Town Board may readopt and reaffirm such Video and Audio Recording policy of the Town of Cheektowaga, NOW, THEREFORE, BE IT

RESOLVED, that this Town Board hereby adopts the attached Video and Audio Recording policy, effective immediately.

Attachments:

videoaudiopolicy (PDF)

RESULT:	ADOPTED [UNANIMOUS]
MOVER:	Mary Holtz, Supervisor
SECONDER:	Diane Benczkowski, Councilmember
AYES:	Holtz, Rogowski, Kaminski, Benczkowski, Meyers
ABSENT:	Angela M. Wozniak



5. RESOLUTION 2014-438

Notice to Bidders - Southcrest Avenue Road Reconstruction (Bid #2014-26)

Sponsored By: Councilmember Meyers, Supervisor Holtz

WHEREAS, it is in order that bids be advertised for the Southcrest Avenue Road Reconstruction Project (Bid 2014-26), AND

WHEREAS, the Engineering Department has prepared plans and specifications for said road reconstruction project, NOW, THEREFORE, BE IT

RESOLVED, that the Town Clerk be directed to publish a Notice to Bidders for the Southcrest Avenue Road Reconstruction Project, said notice to be published in the CHEEKTOWAGA BEE, AND, BE IT FURTHER

RESOLVED, that sealed bids will be received on the 27th day of August, 2014 at 11:00 am at a public bid opening to be held in the Council Chambers in the Cheektowaga Town Hall.



NOTICE TO BIDDERS

Sealed proposals will be received and considered by the Town Board of the Town of Cheektowaga on August 27, 2014 at 11:00 A.M., at the Town Hall, corner of Broadway and Union Roads, Cheektowaga, New York, for the Reconstruction of Southcrest Avenue in the Town of Cheektowaga (Bid 2014-26).

Copies of the proposed Contract Documents, Plans and Specifications may be examined at the Town of Cheektowaga Engineering Department, 275 Alexander Avenue, Cheektowaga, New York 14211. Copies may be obtained from the Town Clerk at her office in Town Hall, Broadway & Union Road, upon the payment of \$50.00 per set of documents. Checks shall be made payable to the Town of Cheektowaga.

Proposals shall be submitted in a sealed envelope, plainly marked on the outside "Bid for Southcrest Avenue Road Reconstruction" and submitted to the Town Clerk prior to bid opening.

No bidder may withdraw his bid within forty-five (45) days after the actual date of the opening thereof. The proposed project is contingent upon bid price and budget constraints.

The Town Board reserves the right to consider informal any bid not prepared and submitted in accordance with the provisions of the specifications and contract documents, and may waive any informalities, make an award to other than the low bidder, should it be in the best interest of the Town, or reject any and all bids.

By Order of the Town Board of the Town of Cheektowaga, Erie County, New York.

Alice Magierski
Town Clerk

Dated: August 4, 2014

RESULT:	ADOPTED [UNANIMOUS]
MOVER:	Timothy J. Meyers, Councilmember
SECONDER:	Mary Holtz, Supervisor
AYES:	Holtz, Rogowski, Kaminski, Benczkowski, Meyers
ABSENT:	Angela M. Wozniak



6. RESOLUTION 2014-439

Approve Purchase of One New and Unused 2014 Caterpillar Backhoe Loader 420F-IT

Sponsored By: Councilmember Kaminski, Supervisor Holtz

WHEREAS, the Town Board authorized the purchase of One New and Unused 2013 Caterpillar Backhoe Loader 420F-IT from Milton-Cat, 4610 East Saile Drive, Batavia, New York 14020, as specified under the contract documents for the Township of Brighton in Monroe County at a regular board meeting on April 15, 2013, AND

WHEREAS, said Township of Brighton contract is renewable for up to a three (3) year period, AND

WHEREAS, the proposed purchase agreement with Milton Cat contains the required language required by section 103-b of the General Municipal Law and otherwise complies with the New York State Law, AND

WHEREAS, Milton Cat offers a one year trade-in program for said equipment, AND

WHEREAS, said trade-in program is based on the hours of use of equipment and any price increase in the Township of Brighton contract, AND

WHEREAS, the Highway Department has requested authorization to trade-in one 2013 Caterpillar Backhoe Loader 420F-IT for one new and unused 2014 Caterpillar Backhoe Loader 420F-IT as specified under the terms of Milton Cat's trade-in program and the Township of Brighton's contract, AND

WHEREAS, funds for said purchase have been budgeted and are available under account number 300-5130-2407, NOW THEREFORE BE IT

RESOLVED, that the Town Board hereby authorizes to trade-in one 2013 Caterpillar Backhoe Loader 420F-IT for one new and unused 2014 Caterpillar Backhoe Loader 420F-IT in the amount of \$6,384.00 from:

Milton Cat
4610 East Saile Drive
Batavia, NY 14020

RESULT:	ADOPTED [UNANIMOUS]
MOVER:	Gerald Kaminski, Councilmember
SECONDER:	Mary Holtz, Supervisor
AYES:	Holtz, Rogowski, Kaminski, Benczkowski, Meyers
ABSENT:	Angela M. Wozniak



7. RESOLUTION 2014-440

Special Event - John F. Kennedy High School Homecoming Parade

Sponsored By: Councilmember Meyers, Councilmember Rogowski

WHEREAS, by resolution dated May 1, 1995, this Town Board adopted a Special Events policy, which requires anyone wishing to hold a special event in the Town to file an application and supporting documentation, fees, etc. To the Town Clerk prior to the special event, and

WHEREAS, the Student Council of John F. Kennedy High School has made application to hold its Homecoming Parade on Saturday, September 6th, 2014, beginning at 12:00 p.m. (parade route attached to application); and

WHEREAS, this Board has reviewed the aforementioned application, which application has been approved by the Cheektowaga Police Department, Highway Department & Parks Department, and has no objection to same, and

WHEREAS, due to the nature of the event, this Town Board hereby waives the following requirements: Submittal of plan for sanitary facilities;

- 1) Submittal of site plan;
- 2) Requirement that application be made at least 60 days prior to the date of the special event;
- 3) Submittal of Security Plan;
- 4) Submittal of Fire Prevention/Emergency Services Plan.

NOW, THEREFORE, BE IT

RESOLVED, that this Town Board hereby approves the aforementioned application of the Student Council of John F. Kennedy High School for the aforementioned parade to be held on Saturday, September 6th, 2014, and BE IT FURTHER

RESOLVED, that the Chief of Police be and hereby is directed to provide traffic safety and escort services for such parade and to ensure compliance with Section 1660 (a)(6) of the Vehicle and Traffic Law.

RESULT:	ADOPTED [UNANIMOUS]
MOVER:	Timothy J. Meyers, Councilmember
SECONDER:	James P. Rogowski, Councilmember
AYES:	Holtz, Rogowski, Kaminski, Benczkowski, Meyers
ABSENT:	Angela M. Wozniak



8. RESOLUTION 2014-441

Unsafe-Unsecured/20 Andrews Avenue

Sponsored By: Supervisor Holtz, Councilmember Benczkowski

WHEREAS, Town of Cheektowaga Law for the Administration and Enforcement of the Codes of New York State; and the Property Maintenance Code of New York State require that all vacant structures and premises shall be maintained in clean, safe, secure and sanitary conditions so as not to cause a blighting problem or adversely affect the public health or safety and all nuisances abated, AND

WHEREAS, the Town of Cheektowaga has received notification of an unsafe structure and premises located at 20 Andrews Avenue, Cheektowaga, New York SBL# 101.28-2-5 that is a danger to the safety of others, and records kept by the Assessors Office identify Mary Dee McInturff, 20 Andrews Avenue, Cheektowaga, New York 14225, as the owner AND

WHEREAS, an inspection of such premises was conducted at 20 Andrews Avenue, by the Housing and Neighborhood Preservation Office, AND

WHEREAS, such inspection found the premises to be deteriorated, vacant, a hazard, and a danger to the safety and well being of others, AND

WHEREAS, the Town of Cheektowaga Housing and Neighborhood Preservation Office properly notified the property owner in accordance with the Town of Cheektowaga Law for the Administration and Enforcement of the Codes of New York State, and the owner failed to take actions to safeguard the premises, AND

WHEREAS, these conditions require the Town of Cheektowaga Housing and Neighborhood Preservation Office to take immediate steps to safeguard the premises to protect the health and safety of others and abate all nuisances, NOW, THEREFORE BE IT

RESOLVED, that pursuant to Section 70-7A.(5) and Section 70-8 of the Town of Cheektowaga Law for the Administration and Enforcement of the Codes of New York State that the vacant structure premises be safeguarded and all nuisances abated; and all costs incurred be assessed against the property hereinbefore described.

RESULT:	ADOPTED [UNANIMOUS]
MOVER:	Mary Holtz, Supervisor
SECONDER:	Diane Benczkowski, Councilmember
AYES:	Holtz, Rogowski, Kaminski, Benczkowski, Meyers
ABSENT:	Angela M. Wozniak



9. RESOLUTION 2014-442

Bonfire-Cheektowaga Central/3600 Union Road

Sponsored By: Supervisor Holtz, Councilmember Benczkowski

WHEREAS, pursuant to the Open Burning Law of the Town of Cheektowaga, the Fire Inspector reviews various applications for open fires and open burning and renders his recommendation concerning the fire safety and impact to the general public of such application, AND

WHEREAS, the Town Board, pursuant to the Open Burning Law of the Town of Cheektowaga, is designated the Approval Agency, AND

WHEREAS, since the Town Board is the Approval Agency, it must affirm, modify or reject any recommendations or permits submitted to it by Joseph Ehnes, Fire Inspector, AND

WHEREAS, an application for a permit was submitted by the Cheektowaga Central High School to conduct a open fire on September 16, 2014 (rain date of September 17, 2014) on the property located at 3600 Union Road, Cheektowaga, New York AND

WHEREAS, the applicant intends to maintain a small bonfire with the assistance of the Forks Fire Department in conjunction with summer youth activities, AND

WHEREAS, Joseph Ehnes, Fire Inspector has received this application and finds that all requirements have been met and that this application is in compliance with conditions and requirement of the Town of Cheektowaga Fire Prevention Code and the Open Burning Law. He requests the Town Board approve issuance of a permit, AND

WHEREAS, this Town Board has reviewed the application submitted by Cheektowaga Central High School and the recommendations of Joseph Ehnes, Fire Inspector, NOW, THEREFORE, BE IT

RESOLVED, that this Town Board, authorizes the Fire Inspector to issue such permit.

RESULT:	ADOPTED [UNANIMOUS]
MOVER:	Mary Holtz, Supervisor
SECONDER:	Diane Benczkowski, Councilmember
AYES:	Holtz, Rogowski, Kaminski, Benczkowski, Meyers
ABSENT:	Angela M. Wozniak



10. RESOLUTION 2014-443

Youth & Recreation Terminations

Sponsored By: Councilmember Rogowski, Councilmember Meyers

BE IT RESOLVED that the individuals listed below be and hereby are terminated in the Department of Youth & Recreational Services effective as indicated:

Christopher Balash	Never worked		14215
Timothy Baumgart	7/11/14		14225
Joseph Creek	Never worked	14225	
Tyler Elis	Never worked		14225
Matthew Lanning	Never worked		14225
Matthew Loos	Never worked		14225
Steven Malicki	Never worked		14206
Leah Polvinale	6/2/14		14227
Corey Smith	6/2/14	14043	
Rob Tighe	Never worked		14225
Allysa Walker	7/2/14		14225
Nakira White	7/2/14		14225
Trevor Wrona	Never worked		14225

Motion by Councilmember Rogowski; Seconded by Councilmember Meyers to waive the reading of names for the following two (2) resolutions: 2014-443 and 2014-444. Motion Carried.

RESULT: ADOPTED [UNANIMOUS]
MOVER: James P. Rogowski, Councilmember
SECONDER: Timothy J. Meyers, Councilmember
AYES: Holtz, Rogowski, Kaminski, Benczkowski, Meyers
ABSENT: Angela M. Wozniak



11. RESOLUTION 2014-444

Hiring of Part Time Employee

Sponsored By: Councilmember Kaminski, Supervisor Holtz

BE IT RESOLVED, that the following individual be and hereby is hired as **SEASONAL EMPLOYEE**, not to exceed five (5) months in a calendar year, in the department listed and in compliance with Civil Service Laws and Regulations as well as the provisions of the Town's collective bargaining agreement between the Town of Cheektowaga and the Town of Cheektowaga Employees Association:

SANITATION DEPARTMENT Laborer \$9.25/hour effective 7/22/14
Louis A. Hyatt, Cheektowaga, New York

RESULT:	ADOPTED [UNANIMOUS]
MOVER:	Gerald Kaminski, Councilmember
SECONDER:	Mary Holtz, Supervisor
AYES:	Holtz, Rogowski, Kaminski, Benczkowski, Meyers
ABSENT:	Angela M. Wozniak



12. RESOLUTION 2014-445

Appointment of Town Engineer

Sponsored By: Supervisor Holtz, Councilmember Kaminski

WHEREAS, William R. Pugh, P.E. has informed this Board that he will be retiring from his position as Town Engineer, effective August 15, 2014, and

WHEREAS, this Board desires to fill the position of Town Engineer, and

WHEREAS, Patrick Bowen, Assistant Town Engineer, has indicated a desire to be promoted to the position of Town Engineer, and meets all of the qualifications for said position, and

WHEREAS, Patrick Bowen is eligible under the Rules of the Classified Civil Services for a non-competitive promotion to the position of Town Engineer, NOW, THEREFORE, BE IT

RESOLVED, that Patrick Bowen of Cheektowaga, New York be and hereby is promoted to the position of Town Engineer, effective August 18, 2014, contingent upon the retirement of William R. Pugh, and further contingent upon Erie County Department of Personnel approving the non-competitive promotion of Patrick Bowen, and BE IT FURTHER

RESOLVED, that the Supervisor be and hereby is authorized and directed to execute the nomination form for the non-competitive promotion and any and all other documents necessary to effectuate the promotion of Patrick Bowen to the position of Town Engineer, and BE IT FURTHER

RESOLVED, that the salary for this position shall be established at \$86,000.00 per year.

RESULT:	ADOPTED [UNANIMOUS]
MOVER:	Mary Holtz, Supervisor
SECONDER:	Gerald Kaminski, Councilmember
AYES:	Holtz, Rogowski, Kaminski, Benczkowski, Meyers
ABSENT:	Angela M. Wozniak



13. RESOLUTION 2014-446

Appoint Interim Supervising Code Enforcement Officer

Sponsored By: Supervisor Holtz, Councilmember Kaminski

WHEREAS, many Town Codes are administered and enforced by the Supervising Code Enforcement Officer of the Town of Cheektowaga (a/k/a Supervising Building & Plumbing Inspector, a/k/a Supervising Building Inspector, a/k/a Town Building Inspector), and

WHEREAS, Thomas J. Adamczak, Supervising Code Enforcement Officer, retired as of July 25, 2014, and

WHEREAS, until such time as a new permanent Supervising Code Enforcement Officer is appointed, there needs to be a temporary appointment to the title of Supervising Code Enforcement Officer under various Town Codes and to administer the Building Inspections Department, and

WHEREAS, Carla A. Kosmerl, Director of Community Development, also oversees the Housing & Neighborhood Preservation Office, and, after successfully completing code enforcement classes, is a Code Enforcement Officer, and

WHEREAS, as such, Carla A. Kosmerl is qualified to serve temporarily as an interim Supervising Code Enforcement Officer, NOW, THEREFORE, BE IT

RESOLVED, that Carla A. Kosmerl, Director of Community Development, be and hereby is designated as interim Supervising Code Enforcement Officer (a/k/a Supervising Building & Plumbing Inspector, a/k/a Supervising Building Inspector, a/k/a Town Building Inspector) of the Town of Cheektowaga to administer and enforce various Town Codes and to administer the Office of Building Inspections, effective immediately, and BE IT FURTHER,

RESOLVED, that Carla A. Kosmerl shall have authority under all existing Town Codes to act as Supervising Code Enforcement Officer (a/k/a Supervising Building & Plumbing Inspector, a/k/a Supervising Building Inspector, a/k/a Town Building Inspector).

RESULT:	ADOPTED [UNANIMOUS]
MOVER:	Mary Holtz, Supervisor
SECONDER:	Gerald Kaminski, Councilmember
AYES:	Holtz, Rogowski, Kaminski, Benczkowski, Meyers
ABSENT:	Angela M. Wozniak



14. RESOLUTION 2014-447

Retention of Engineering Consultant

Sponsored By: Supervisor Holtz, Councilmember Kaminski

WHEREAS, William R. Pugh, P.E. retired from his position as Town Engineer, effective August 15, 2014, and

WHEREAS, because of the many years of knowledge and expertise of William R. Pugh, P.E., there is a need to retain his services temporarily to assist the Town as a consultant to the Engineering Department, and

WHEREAS, William R. Pugh has agreed to work as a consultant to the Town Engineering Department, NOW, THEREFORE, BE IT

RESOLVED, that William R. Pugh, P.E., be and hereby is retained by the Town as an engineering consultant, at the rate of \$366.00, per day, effective August 18, 2014, and BE IT FURTHER

RESOLVED, that the Supervisor be and hereby is authorized and directed to execute any and all documents in connection with this matter.

RESULT:	ADOPTED [UNANIMOUS]
MOVER:	Mary Holtz, Supervisor
SECONDER:	Gerald Kaminski, Councilmember
AYES:	Holtz, Rogowski, Kaminski, Benczkowski, Meyers
ABSENT:	Angela M. Wozniak



15. RESOLUTION 2014-448

Travel Authorization Police Department/Lieutenant Patrick Chludzinski

Sponsored By: Councilmember Benczkowski, Councilmember Kaminski

WHEREAS, the 10th Annual IAPRO Users Conference is being held November 3 through November 6, 2014 in St. Petersburg, Florida; AND

WHEREAS, Lieutenant Patrick Chludzinski has been recommended to attend said conference; AND

WHEREAS, Police Chief David Zack has submitted a request for travel authorization along with the proper paperwork in a timely manner; AND

WHEREAS, the total cost to the Town shall not exceed \$1,288; AND

WHEREAS, these expenses have been budgeted by the Department; NOW, THEREFORE, BE IT

RESOLVED, that Lieutenant Patrick Chludzinski be and hereby is authorized to attend the 10th Annual IAPRO Users Conference being held November 3 through November 6, 2014 in St. Petersburg, Florida.

RESULT:	ADOPTED [UNANIMOUS]
MOVER:	Diane Benczkowski, Councilmember
SECONDER:	Gerald Kaminski, Councilmember
AYES:	Holtz, Rogowski, Kaminski, Benczkowski, Meyers
ABSENT:	Angela M. Wozniak

V. Communications

A. Departmental Communications

1. Supervisor's Statement of Funds - June 2014
2. Town of Cheektowaga Board of Assessment Review Hearing Results for 2014
3. Minutes: Town Environmental Advisory Committee - June 25, 2014
4. Minutes: Cheektowaga Planning Board - July 10, 2014

B. General Communications

1. **Summons & Complaint: EPK Properties, LLC vs. Town of Cheektowaga**
2. **Notice of Claim: Adirondack Ins. Exchange a/s/o Duane DiPirro vs. Town of Cheektowaga**
3. **Notice of Claim: GEICO a/s/o Karin A Brzezowski vs. Town of Cheektowaga**
4. **Notice of Claim: Progressive a/s/o Jason Hernandez vs. Town of Cheektowaga**
5. **Notice of Claim: Robert Sauer vs. Town of Cheektowaga**
6. **Notice of Claim: Richard Viggato vs. Town of Cheektowaga**
7. **Notice of Petition: Carrols Corporation #490 vs. Assessor and the Board of Assessment Review of the Town of Cheektowaga and the Town of Cheektowag, County of Erie, New York**
8. **Notice of Petition: Holland Motor Express vs. Assessor and the Board of Assessment Review of the Town of Cheektowaga and the Town of Cheektowag, County of Erie, New York**
9. **Notice of Petition: US Foodservice Corporation vs. Assessor and the Board of Assessment Review of the Town of Cheektowaga and the Town of Cheektowag, County of Erie, New York**
10. **Notice of Petition: Carrols Corporation #512 vs. Assessor and the Board of Assessment Review of the Town of Cheektowaga and the Town of Cheektowag, County of Erie, New York**
11. **Notice of Petition: United Parcel Service vs. Assessor and the Board of Assessment Review of the Town of Cheektowaga and the Town of Cheektowag, County of Erie, New York**
12. **Notice of Petition: UPS Supply Chain Solutions vs. Assessor and the Board of Assessment Review of the Town of Cheektowaga and the Town of Cheektowag, County of Erie, New York**
13. **Notice of Petition: Buffalo WVP Associates, LLC vs. Assessor and the Board of Assessment Review of the Town of Cheektowaga and the Town of Cheektowag, County of Erie, New York**
14. **Notice of Petition: KQ Bell Towers of Erie LLC; Towers of Erie LLC and Tri City Rentals, LLC vs. Assessor and the Board of Assessment Review of the Town of Cheektowaga and the Town of Cheektowag, County of Erie, New York**
15. **Notice of Petition: Grunin LLC vs. Assessor and the Board of Assessment Review of the Town of Cheektowaga and the Town of Cheektowag, County of Erie, New York**
16. **Notice of Petition: Buffalo RHM Operating LLC vs. Assessor and the Board of Assessment Review of the Town of Cheektowaga and the Town of Cheektowag, County of Erie, New York**

17. **Notice of Petition: LT Propco LLC vs. Assessor and the Board of Assessment Review of the Town of Cheektowaga and the Town of Cheektowag, County of Erie, New York**
18. **Notice of Petition: Macy's Retail Holdings, Inc. vs. Assessor and the Board of Assessment Review of the Town of Cheektowaga and the Town of Cheektowag, County of Erie, New York**
19. **Notice of Petition: JMDH Real Estate of Buffalo LLC vs. Assessor and the Board of Assessment Review of the Town of Cheektowaga and the Town of Cheektowag, County of Erie, New York**
20. **Notice of Petition: Target #1014 vs. Assessor and the Board of Assessment Review of the Town of Cheektowaga and the Town of Cheektowag, County of Erie, New York**
21. **Notice of Petition: Target #2191 vs. Assessor and the Board of Assessment Review of the Town of Cheektowaga and the Town of Cheektowag, County of Erie, New York**
22. **Notice of Petition: 151 Bennett Road LLC; 225 Bennett Road LLC vs. Assessor and the Board of Assessment Review of the Town of Cheektowaga and the Town of Cheektowag, County of Erie, New York**
23. **Notice of Petition: Erie Logistics LLC vs. Assessor and the Board of Assessment Review of the Town of Cheektowaga and the Town of Cheektowag, County of Erie, New York**
24. **Notice of Petition: Tops Markets, LLC vs. Assessor and the Board of Assessment Review of the Town of Cheektowaga and the Town of Cheektowag, County of Erie, New York**
25. **Notice of Petition: HD Development of Maryland Inc. vs. Assessor and the Board of Assessment Review of the Town of Cheektowaga and the Town of Cheektowag, County of Erie, New York**
26. **Notice of Petition: DDR MDT Union Consumer Square, LLC vs. Assessor and the Board of Assessment Review of the Town of Cheektowaga and the Town of Cheektowag, County of Erie, New York**
27. **Notice of Petition: Niagara Mohawk Power Corporation d/b/a National Grid vs. Assessor and the Board of Assessment Review of the Town of Cheektowaga and the Town of Cheektowag, County of Erie, New York**
28. **Notice of Petition: Rite Aid Corporation/Eckerd Corporation vs. Assessor and the Board of Assessment Review of the Town of Cheektowaga and the Town of Cheektowag, County of Erie, New York**
29. **Notice of Petition: Idylwood LLC and Morgan Management vs. Assessor and the Board of Assessment Review of the Town of Cheektowaga and the Town of Cheektowag, County of Erie, New York**
30. **Notice of Petition: WPH Airport Associates vs. Assessor and the Board of Assessment Review of the Town of Cheektowaga and the Town of Cheektowag, County of Erie, New York**
31. **Notice of Petition: ATA Associates vs. Assessor and the Board of Assessment Review of the Town of Cheektowaga and the Town of Cheektowag, County of Erie, New York**

32. **Notice of Petition: MDC Concourse Center, LLC vs. Assessor and the Board of Assessment Review of the Town of Cheektowaga and the Town of Cheektowag, County of Erie, New York**
33. **Notice of Petition: DDR MDT Walden Square LLC vs. Assessor and the Board of Assessment Review of the Town of Cheektowaga and the Town of Cheektowag, County of Erie, New York**
34. **Notice of Petition: French/Borden Partners, LLC c/o Walgreens vs. Assessor and the Board of Assessment Review of the Town of Cheektowaga and the Town of Cheektowag, County of Erie, New York**
35. **Notice of Petition: DDR Union Road LLC vs. Assessor and the Board of Assessment Review of the Town of Cheektowaga and the Town of Cheektowag, County of Erie, New York**
36. **Notice of Petition: RE FUND SKY HARBOR PROPERTY LLC, (all properties within Sky Harbor) vs. Assessor and the Board of Assessment Review of the Town of Cheektowaga and the Town of Cheektowag, County of Erie, New York**
37. **Notice of Petition: Century Professional Building, LLC vs. Assessor and the Board of Assessment Review of the Town of Cheektowaga and the Town of Cheektowag, County of Erie, New York**
38. **Notice of Petition: Walden Properties, LLC vs. Assessor and the Board of Assessment Review of the Town of Cheektowaga and the Town of Cheektowag, County of Erie, New York**
39. **Notice of Petition: 340/350 Nagel Drive LLC vs. Assessor and the Board of Assessment Review of the Town of Cheektowaga and the Town of Cheektowag, County of Erie, New York**
40. **Notice of Petition: Kabir's LLC vs. Assessor and the Board of Assessment Review of the Town of Cheektowaga and the Town of Cheektowag, County of Erie, New York**
41. **Notice of Petition: 3770 Union Road vs. Assessor and the Board of Assessment Review of the Town of Cheektowaga and the Town of Cheektowag, County of Erie, New York**
42. **Notice of Petition: CM Scrivner, LLC vs. Assessor and the Board of Assessment Review of the Town of Cheektowaga and the Town of Cheektowag, County of Erie, New York**
43. **Notice of Petition: Keller Chevrolet, Inc. vs. Assessor and the Board of Assessment Review of the Town of Cheektowaga and the Town of Cheektowag, County of Erie, New York**
44. **Notice of Petition: Kabir Group, Inc., Kabir Hotels, Inc and Matajjs, Inc. vs. Assessor and the Board of Assessment Review of the Town of Cheektowaga and the Town of Cheektowag, County of Erie, New York**
45. **Notice of Petition: McDonald's USA, LLC vs. Assessor and the Board of Assessment Review of the Town of Cheektowaga and the Town of Cheektowag, County of Erie, New York**
46. **Notice of Petition: Goldi Group, Inc. vs. Assessor and the Board of Assessment Review of the Town of Cheektowaga and the Town of Cheektowag, County of Erie, New York**

47. **Notice of Petition: Marygold Manor, Inc. vs. Assessor and the Board of Assessment Review of the Town of Cheektowaga and the Town of Cheektowag, County of Erie, New York**
48. **Notice of Petition: RMF Holding, Inc. vs. Assessor and the Board of Assessment Review of the Town of Cheektowaga and the Town of Cheektowag, County of Erie, New York**
49. **Notice of Petition: Iskalo Real Estate Partnership vs. Assessor and the Board of Assessment Review of the Town of Cheektowaga and the Town of Cheektowag, County of Erie, New York**
50. **Notice of Petition: Hutch Enterprises, Inc., vs. Assessor and the Board of Assessment Review of the Town of Cheektowaga and the Town of Cheektowag, County of Erie, New York**
51. **Notice of Petition: Sheridan Carmen LLC a/k/a 132 Cayuga Road vs. Assessor and the Board of Assessment Review of the Town of Cheektowaga and the Town of Cheektowag, County of Erie, New York**
52. **Notice of Petition: P. Lebourg, Inc. vs. Assessor and the Board of Assessment Review of the Town of Cheektowaga and the Town of Cheektowag, County of Erie, New York**
53. **Notice of Petition: 3500 Genesee Associates, LLC vs. Assessor and the Board of Assessment Review of the Town of Cheektowaga and the Town of Cheektowag, County of Erie, New York**
54. **Notice of Petition: Frank E. Bork, III vs. Assessor and the Board of Assessment Review of the Town of Cheektowaga and the Town of Cheektowag, County of Erie, New York**
55. **Notice of Petition: 2485 Broadway, LLC & 2065 Harlem Road, LLC vs. Assessor and the Board of Assessment Review of the Town of Cheektowaga and the Town of Cheektowag, County of Erie, New York**
56. **Notice of Petition: Shaw Partners vs. Assessor and the Board of Assessment Review of the Town of Cheektowaga and the Town of Cheektowag, County of Erie, New York**
57. **Notice of Petition: Iskalo Properties, LLC vs. Assessor and the Board of Assessment Review of the Town of Cheektowaga and the Town of Cheektowag, County of Erie, New York**
58. **Notice of Petition: Lovullo Associates, Inc. & Marauder Enterprises LLC vs. Assessor and the Board of Assessment Review of the Town of Cheektowaga and the Town of Cheektowag, County of Erie, New York**
59. **Notice of Petition: Urbandale Development vs. Assessor and the Board of Assessment Review of the Town of Cheektowaga and the Town of Cheektowag, County of Erie, New York**
60. **Notice of Petition: Har-Wal Associates Inc. vs. Assessor and the Board of Assessment Review of the Town of Cheektowaga and the Town of Cheektowag, County of Erie, New York**
61. **Notice of Petition: Walden Avenue Realty vs. Assessor and the Board of Assessment Review of the Town of Cheektowaga and the Town of Cheektowag, County of Erie, New York**

62. Notice of Petition: Marshall Kimmins vs. Assessor and the Board of Assessment Review of the Town of Cheektowaga and the Town of Cheektowag, County of Erie, New York
63. Notice of Petition: Rotor Motion, Inc. vs. Assessor and the Board of Assessment Review of the Town of Cheektowaga and the Town of Cheektowag, County of Erie, New York
64. Notice of Petition: Bhavani Associates, LLC vs. Assessor and the Board of Assessment Review of the Town of Cheektowaga and the Town of Cheektowag, County of Erie, New York
65. Notice of Petition: 2745 Broadway, LLC vs. Assessor and the Board of Assessment Review of the Town of Cheektowaga and the Town of Cheektowag, County of Erie, New York
66. Notice of Petition: Bhavani Group, Inc. vs. Assessor and the Board of Assessment Review of the Town of Cheektowaga and the Town of Cheektowag, County of Erie, New York
67. Notice of Petition: Lockport Properties LLC vs. Assessor and the Board of Assessment Review of the Town of Cheektowaga and the Town of Cheektowag, County of Erie, New York

VI. Comments

A. Supervisor's Comments

B. Councilmember's Comments

C. Public Comments

VII. Adjourn

Motion by Supervisor Holtz; Seconded by Councilmember Kaminski to adjourn the meeting at 7:25 PM.

Alice Magierski, Town Clerk

VIDEO AND AUDIO RECORDING POLICY

Overview: The purpose of this policy is to address retention and storage issues associated with video surveillance/security and audio records, with the exception of Police Car Video/Audio and investigative records.

Recording the voice and/or image of an individual creates a type of record that requires unique handling and storage, particularly if the content may be considered administrative or having potential legal uses.

Policy Elements:

- Purpose and use of recording
- People who will have access to the recording(s)
- Storage procedures, the storage location
- Retention Procedures
- Procedures for controlling access to and use of the recordings
- Purging of Recordings

The Town of Cheektowaga reserves the right to place video/audio monitoring and/or recording equipment on its premises where necessary and appropriate. This policy applies to video and audio related property and records owned, maintained, or controlled by the Town of Cheektowaga.

NOTE: At no time should an employee expect privacy in work-related areas as a part of daily business operations.

Policy:

I. Video Surveillance and Audio Monitoring Equipment

- A. The acquisition and installation of video/audio monitoring and/or recording equipment must be coordinated and approved through the Department of Information Services department head.
- B. The Town of Cheektowaga will not make video or audio recordings or conduct surveillance without the proper and legal acknowledgments and/or postings as required by law, policy, rule or regulation.
- C. False, empty, dummy or inactive cameras will not be used.

II. Video Surveillance

In order to promote the safety of employees and visitors, as well as the security of Town facilities, the Town may conduct video surveillance of any portion of its premises at any time, the only exception being private areas of restrooms, locker rooms and showers. The Town may conduct video\audio surveillance for security purposes of any building, facility, or town owned property.

III. Review of Audio/Video Surveillance Recordings

Only authorized personnel shall be able to review and export the audio/video surveillance recordings. The authorized personnel will be designated by the Department of Information Services department head (all Town business and personnel matters) and the Chief of Police (criminal matters and public safety). If any questions arise as to who is an authorized individual, the Department of Information Services department head and/or the Chief of Police will make the final determination as to who may view the audio/video surveillance recording.

Audit Trails will be reviewed and exported by authorized personnel at the request of the department superior.

Currently, authorized personnel include, the SPSD Senior Public Safety Dispatcher, the Headquarters and Support Services Lieutenant, and the designated Computer Support Technician.

IV. Audio/Video Monitoring Storage

The recording media shall be stored on the Town's recording servers as designated by the authorized Computer Support Technician and shall be retained in accordance with this policy and regulations and rules of the NYS MU-1 Schedule retention requirements (see Appendix A).

V. Release of Recordings

Video or audio recordings will not be viewed or released outside of the Town of Cheektowaga unless required by NYS Freedom of Information Law or other applicable law or regulation, or as deemed appropriate by the Department of Information Services department head and/or the Chief of Police. Freedom of Information requests should be directed to the Town's Records Access Officer for review and release.

VI. Destruction or Tampering with Video/Audio Recording Equipment

Any person who tampers with or willfully destroys any video/audio monitoring and/or recording equipment or recorded video/audio or any part of the equipment or recorded video/audio may be disciplined up to and including dismissal from the Town of Cheektowaga.

VII. Reporting/Capture of Video/Audio Records

A. Should an event be reported to administrative staff, authorized personnel are required to download and save the relevant Video/Audio Records. An event is any occurrence, regardless of incident, in which an individual reports an issue.

B. If an incident occurs, or an individual has reason to believe an incident occurs, the requesting individual has 18 business days (Monday – Friday) to report the occurrence. If the incident is not reported within the first 18 business days of the occurrence, the Town of Cheektowaga cannot guarantee

that the video/audio is available. An incident only becomes an incident to be managed by the Town of Cheektowaga if it is reported.

Reporting of the incident has to be to one of the authorized personnel as stated above within the first 18 days of the incident.

VIII. Purging of Video/Audio

All Town of Cheektowaga video/audio records will be deleted from the server on a thirty day calendar cycle. Town equipment will only maintain video/audio for thirty days, at which time, the video/audio is automatically set to purge (with the exception of Police Car video and investigative records). Once the records are purged, they cannot be retrieved.

The Town of Cheektowaga will assume if an incident is not reported, video consists of “non-event” related records and the purging cycle and appropriate retentions will be applied.

IX. Department of Information Services Responsibility

A. The IT staff shall be responsible for all aspects of equipment, its installation and maintenance, and the purging of video/audio records according to the policy purging cycle.

B. An inventory of all cameras, including the type of cameras, location, viewing capacity, server location, installation date, etc. shall be maintained as an updated record and filed annually with the Records Management Department. The designated Computer Support Technician will report to Headquarters and Support Services Lieutenant and the Department of Information Services issues with any cameras and/or report cameras which are down, outdated, or in the process of repair.

X. Voicemail Recordings

The authorized Computer Support Technician will purge all voicemail records once notified by any Department Head if/when an individual no longer uses the assigned telephone extension within three months of the change in use.

DISCLAIMER:

The Town Municipal Records Manager reserves the right to make changes to this policy on an annual basis as part of records retention updates and yearly review with members of the IT Committee, at which time, should any changes occur, the updated policy will be approved by the Town Board.

NOTE: The prisoner phone vendor, TIPS Systems, maintains the inmate phone systems and retains the phone records for two years. (Meets State Retention 07/25/2014, MU-1 [781b])

NOTE II: In the 911 system, maintained by NICE Information Systems, the records are purged and then maintained in the CHARMS System which is retained permanently with the County of Erie. Backup records are also maintained by the Town on the CPD server. (Meets State Retention 07/25/2014, MU-1 [2]b)

APPENDIX

Video and Audio Retention

[781] Video tape or other recording (audio) maintained for security purposes

a. Videotape or other recording containing incidents warranting retention for administrative or potential legal uses:

RETENTION: 3 years (assuming the records relevant to cases or long term legal requirements are placed with the case file) OR until any minor attains age 21

b. Videotape or other recording NOT containing incidents warranting retention for administrative or potential legal uses:

RETENTION: Disposed of through the 30 day recording cycle

[2] Recording of voice conversations, including audio tape and videotape

b. Recording other than of public meeting:

RETENTION: Disposed of through the 30 day recording cycle



Town of Cheektowaga

Work Session

~ Minutes ~

3301 Broadway
Cheektowaga, NY 14227
<http://www.town.cheektowaga.ny.us>

Alice Magierski
716-686-3400

Tuesday, August 12, 2014

6:00 PM

Council Office

I. Call to Order

6:00 PM Meeting called to order on August 12, 2014 at Council Office, Conference Room, Cheektowaga, NY.

Attendee Name	Organization	Title	Status	Arrived
Mary Holtz	Town of Cheektowaga	Supervisor	Present	
James P. Rogowski	Town of Cheektowaga	Councilmember	Absent	
Gerald Kaminski	Town of Cheektowaga	Councilmember	Present	
Angela M. Wozniak	Town of Cheektowaga	Councilmember	Present	
Diane Benczkowski	Town of Cheektowaga	Councilmember	Present	
Timothy J. Meyers	Town of Cheektowaga	Councilmember	Absent	

2. Additional Attendees

Brian Krause, Director of Finance and Administration
Karen Marchese, Coordinator of Employee Relations
Kevin Schenk, Town Attorney

3. Motion To: Enter Into Executive Session

COMMENTS - Current Meeting:

To Discuss matters relating to appointment, dismissal and termination of employees and litigation matters.

RESULT: ADOPTED [UNANIMOUS]
MOVER: Mary Holtz, Supervisor
SECONDER: Gerald Kaminski, Councilmember
AYES: Mary Holtz, Gerald Kaminski, Angela M. Wozniak, Diane Benczkowski
ABSENT: James P. Rogowski, Timothy J. Meyers

4. Motion To: Exit Executive Session at 620 PM

RESULT: ADOPTED [UNANIMOUS]
MOVER: Diane Benczkowski, Councilmember
SECONDER: Angela M. Wozniak, Councilmember
AYES: Mary Holtz, Gerald Kaminski, Angela M. Wozniak, Diane Benczkowski
ABSENT: James P. Rogowski, Timothy J. Meyers

II. Resolutions at 6:21 PM



1. RESOLUTION 2014-449

Appointment of Appointing Authority (Karen R. Marchese)

Sponsored By: Councilmember Kaminski, Supervisor Holtz

WHEREAS, Erie County Civil Service law stipulates that the Town must appoint an "Appointing Authority" to perform various functions, including the completion and execution of various official personnel forms, personnel changes and reports; AND

WHEREAS, the Personnel Department has been performing these functions and is the proper office in the Town's departmental structure for these functions; THEREFORE, BE IT

RESOLVED, that Coordinator of Employee Relations Karen R. Marchese be and hereby is designated the Town of Cheektowaga's "Appointing Authority" effective August 12, 2014, and that a copy of this resolution be forwarded to the Commissioner of the Erie County Personnel Department.

RESULT:	ADOPTED [UNANIMOUS]
MOVER:	Gerald Kaminski, Councilmember
SECONDER:	Mary Holtz, Supervisor
AYES:	Mary Holtz, Gerald Kaminski, Angela M. Wozniak, Diane Benczkowski
ABSENT:	James P. Rogowski, Timothy J. Meyers



2. RESOLUTION 2014-450

Appointment of Drug Enforcement Representative (Karen R. Marchese)

Sponsored By: Councilmember Kaminski, Supervisor Holtz

BE IT RESOLVED, Coordinator of Employee Relations Karen R. Marchese be and hereby is designated the Town's "Drug Enforcement Representative" effective August 12, 2014.

RESULT:	ADOPTED [UNANIMOUS]
MOVER:	Gerald Kaminski, Councilmember
SECONDER:	Mary Holtz, Supervisor
AYES:	Mary Holtz, Gerald Kaminski, Angela M. Wozniak, Diane Benczkowski
ABSENT:	James P. Rogowski, Timothy J. Meyers



3. RESOLUTION 2014-451

Settlement of Litigation

Sponsored By: Supervisor Holtz, Councilmember Kaminski

WHEREAS, an action was commenced against the Town of Cheektowaga in the United States District Court in the Western District of New York (Civil Action No. 1:13-CV-00985-a); and

WHEREAS, the law firm of Phillips Lytle LLP (James D. Donathen, Esq., of counsel) was retained to represent the Town; vigorously defended the interests of the Town with regard to this claim; and has recommended a settlement with the claimants' attorney; and

WHEREAS, this settlement is in the best interest of the Town of Cheektowaga; NOW THEREFORE, BE IT

RESOLVED, that the Town Board approves of the above settlement in accord with the Stipulation of Discontinuance and Settlement Agreement, Release and Waiver signed by the plaintiffs, and the Town Supervisor and/or James D. Donathen, Esq.. be and hereby are authorized to execute and procure all papers necessary to effectuate said settlement and compromise of the above mentioned claim in accordance with the terms of the Settlement Agreement, Release and Waiver, and the Stipulation of Discontinuance.

RESULT:	ADOPTED [UNANIMOUS]
MOVER:	Mary Holtz, Supervisor
SECONDER:	Gerald Kaminski, Councilmember
AYES:	Mary Holtz, Gerald Kaminski, Angela M. Wozniak, Diane Benczkowski
ABSENT:	James P. Rogowski, Timothy J. Meyers



Town of Cheektowaga

Regular Meeting

~ Minutes ~

3301 Broadway
Cheektowaga, NY 14227
<http://www.town.cheektowaga.ny.us>

Alice Magierski
716-686-3400

Monday, August 18, 2014

6:45 PM

Council Chambers

I. Call to Order

6:45 PM Meeting called to order on August 18, 2014 at Council Chambers, 3301 Broadway St, Cheektowaga, NY.

Attendee Name	Organization	Title	Status	Arrived
Mary Holtz	Town of Cheektowaga	Supervisor	Present	
James P. Rogowski	Town of Cheektowaga	Councilmember	Present	
Gerald Kaminski	Town of Cheektowaga	Councilmember	Present	
Angela M. Wozniak	Town of Cheektowaga	Councilmember	Present	
Diane Benczkowski	Town of Cheektowaga	Councilmember	Present	
Timothy J. Meyers	Town of Cheektowaga	Councilmember	Present	

2. Additional Attendees

Patrick Bowen, Town Engineer
Robert Brandon, Zoning Board Chairman
Carla A. Kosmerl, Director of Community Development
Brian Krause, Director of Finance and Administration
Kevin Schenk, Town Attorney

II. Public Comment Period

A. Proclamation

By Councilmember Meyers to Delcare September Childhood Cancer Awareness Month.

III. Resolutions



1. RESOLUTION 2014-452

Transfer of Funds

Sponsored By: Councilmember Kaminski, Supervisor Holtz

BE IT RESOLVED, that the following transfer is hereby approved and made part hereof;
HIGHWAY

FROM: 300.1910.2665 Revenue Account \$11,200.00

TO: 300.5130.2407 Highway Equipment \$11,200.00

RESULT: ADOPTED [UNANIMOUS]

MOVER: Gerald Kaminski, Councilmember

SECONDER: Mary Holtz, Supervisor

AYES: Holtz, Rogowski, Kaminski, Wozniak, Benczkowski, Meyers



2. RESOLUTION 2014-453

Warrant

Sponsored By: Councilmember Kaminski, Supervisor Holtz

BE IT RESOLVED, that the following Vouchers & Warrants submitted to the Town of Cheektowaga prior to August 18, 2014 are hereby approved and made part hereof;

GENERAL FUND	\$214,261.56
RISK RETENTION FUND	22,198.50
NYS HOME PROGRAM	0.00
DEBT	5,466.66
HUD HOUSING REHABILITATION FUND	20,601.00
SPECIAL DISTRICTS FUND	365,185.19
HIGHWAY FUND	447,211.81
CAPITAL FUND	177,426.60
TRUST & AGENCY FUND	34,210.21
HUD CDBG FUND	1,332.29
PART TOWN FUND	3,692.68
NYS AFFORDABLE HOUSING	0.00
	\$1,291,586.50

RESULT:	ADOPTED [UNANIMOUS]
MOVER:	Gerald Kaminski, Councilmember
SECONDER:	Mary Holtz, Supervisor
AYES:	Holtz, Rogowski, Kaminski, Wozniak, Benczkowski, Meyers



3. RESOLUTION 2014-454

Award of Bid - Equipment & Operators for the Cleaning, Televising and Grouting of Various Sanitary Sewers (Bid #2014-27)

Sponsored By: Councilmember Meyers, Supervisor Holtz

WHEREAS, as a result of advertisement, bids were received on August 6, 2014 for the furnishing of equipment and operators for the cleaning, televising and grouting of various sanitary sewers in the Town of Cheektowaga, AND

WHEREAS, said bids were referred to the Town Engineer for analysis, tabulation and report, which tabulation and report is contained in a letter from the Town Engineer dated August 14, 2014, NOW, THEREFORE, BE IT

RESOLVED, that the contract for the furnishing of equipment & operators for the grouting, cleaning and televising of various sanitary sewers for the balance of the 2014 calendar year be awarded to:

Sewer Specialty Services Company, Inc.
2462 New Road
Leicester, New York 14481

for submission of the lowest bid meeting the requirements of the specifications in the amount of \$3,200.00/day for equipment & operators and \$10.00/gallon for grouting agent, AND, BE IT FURTHER

RESOLVED, that funds have been budgeted in Account No. 255-8125-4543 for the associated rehabilitation work.

RESULT:	ADOPTED [UNANIMOUS]
MOVER:	Timothy J. Meyers, Councilmember
SECONDER:	Mary Holtz, Supervisor
AYES:	Holtz, Rogowski, Kaminski, Wozniak, Benczkowski, Meyers



4. RESOLUTION 2014-455

Award of Bid - Equipment & Operators for the Installation of Cured-in-Place Sanitary Sewer Point Repairs (Bid #2014-30)

Sponsored By: Councilmember Meyers, Supervisor Holtz

WHEREAS, as a result of advertisement, bids were received on August 6, 2014 for the furnishing of equipment & operators for the installation of cured-in-place sanitary sewer point repairs in the Town of Cheektowaga, AND

WHEREAS, said bids were referred to the Town Engineer for analysis, tabulation and report, which tabulation and report is contained in a letter from the Town Engineer dated August 14, 2014, NOW, THEREFORE, BE IT

RESOLVED, that the contract for the furnishing of equipment & operators for the installation of cured-in-place sanitary sewer point repairs be awarded to:

Sewer Specialty Services Company, Inc.
2462 New Road
Leicester, New York 14481

for submission of the lowest bid meeting the requirements of the specifications in the amount of \$3,200.00/day for equipment & operators and the unit prices for the various diameter, material repair lengths stated below:

- 1) 8" diameter, 2' long point repair materials: \$ 650.00 each
- 2) 8" diameter, 4' long point repair materials: \$1,300.00 each
- 3) 10" diameter, 2' long point repair materials: \$ 650.00 each
- 4) 10" diameter, 4' long point repair materials: \$1,300.00 each
- 5) 12" diameter, 2' long point repair materials: \$ 700.00 each
- 6) 12" diameter, 4' long point repair materials: \$1,400.00 each

AND, BE IT FURTHER

RESOLVED, that funds have been budgeted in the Consolidated Sewer District Account No. 255-8125-4543 for this work.

RESULT:	ADOPTED [UNANIMOUS]
MOVER:	Timothy J. Meyers, Councilmember
SECONDER:	Mary Holtz, Supervisor
AYES:	Holtz, Rogowski, Kaminski, Wozniak, Benczkowski, Meyers



5. RESOLUTION 2014-456

Accept Site Plan-225-229 Bennett Road Elderwood of Cheektowaga

Sponsored By: Councilmember Benczkowski, Councilmember Rogowski

WHEREAS, pursuant to the Zoning Law of the Town of Cheektowaga, the Planning Board reviews various development review applications for site plans, rezonings, special permits and realty subdivisions and renders its recommendation concerning the compatibility of such application with the zoning regulations, the Town Master Plan and neighborhood character, AND

WHEREAS, the Town Board, pursuant to section 260-47.1C of the Zoning Law of the Town of Cheektowaga is vested with the authority to approve site plans and modify or reject any recommendation submitted to it by its advisory committees, AND

WHEREAS, William Cisak, R.A. on behalf of Elderwood of Cheektowaga submitted a development review application for the construction of a parking area expansion to accommodate (39) additional parked cars at 225-229 Bennett Road, AND

WHEREAS, the Town of Cheektowaga Planning Board, reviewed and commented on the Application at their meeting of July 10, 2014 and have recommended approval thereof, NOW THEREFORE BE IT,

RESOLVED, that pursuant to Section 260-47-1 of the Code of the Town of Cheektowaga and Section 274-a of New York State Town Law that this Town Board approves the proposed site plan subject to :

1. The Town Engineer reviewing and approving the grading/drainage plans.
2. Compensatory trees being providing for each tree (4) inches or greater being removed pursuant to section 229-5 of the Town Code
3. Submission of a revised landscaping plan to the Town Planner for review and approval

RESULT:	ADOPTED [UNANIMOUS]
MOVER:	Diane Benczkowski, Councilmember
SECONDER:	James P. Rogowski, Councilmember
AYES:	Holtz, Rogowski, Kaminski, Wozniak, Benczkowski, Meyers



6. RESOLUTION 2014-457

Reject and Readvertise for Bids for Demolition with Asbestos Abatement of 42 Avery Place (BID 2014-31 LAW)

Sponsored By: Supervisor Holtz, Councilmember Benczkowski

WHEREAS, by resolution dated July 21, 2014 (Resolution 2014-414), this Town Board advertised for bids for the demolition and asbestos abatement of structures located at 42 Avery Place, and

WHEREAS, a sole bid proposal was received and opened on July 30, 2014; and

WHEREAS, based on review of the proposal and bid specifications by the Building Inspections and Housing Department Committee and the Town Attorney, it has been recommended that this Town Board reject the bid received and re-bid this matter, NOW, THEREFORE, BE IT

RESOLVED, that the aforementioned bid received on July 30, 2014 be and hereby is rejected, and BE IT FURTHER

RESOLVED, that the Town Clerk be and hereby is directed to publish a Notice to Bidders (BID 2014-31 LAW) for the demolition and asbestos abatement of structures located at 42 Avery Place, said notice to be published in the CHEEKTOWAGA BEE, and BE IT FURTHER

RESOLVED, that sealed bids will be received and opened by the Town Clerk at a public bid opening to be held in the Council Chambers at the Cheektowaga Town Hall on Wednesday, August 27, 2014 at 11:00 A.M.



NOTICE TO BIDDERS

Sealed proposals will be received by the Town Clerk of the Town of Cheektowaga on Wednesday, August 27, 2014 at 11:00 A.M. at the Cheektowaga Town Hall, 3301 Broadway, Cheektowaga, New York, for the demolition and asbestos abatement of structures located at 42 Avery Place (BID 2014-31 LAW), situate in the Town of Cheektowaga, New York.

Information for bidders and specifications may be obtained from the Town Clerk at her office in said Town.

The Town Board reserves the right to consider informal any bid not prepared and submitted in accordance with the provisions of the specification and contract documents, and may waive any informalities, make an award to other than the low bidder, or reject any or all bids should it be in the best interest of the Town.

BY ORDER OF THE TOWN BOARD OF THE TOWN OF CHEEKTOWAGA, ERIE COUNTY, NEW YORK.

Alice Magierski, Town Clerk

Dated: 18 August 2014

RESULT:	ADOPTED [UNANIMOUS]
MOVER:	Mary Holtz, Supervisor
SECONDER:	Diane Benczkowski, Councilmember
AYES:	Holtz, Rogowski, Kaminski, Wozniak, Benczkowski, Meyers



7. RESOLUTION 2014-458

Authorize Supervisor to Execute Enrollment Renewal Form with Energy Curtailment Specialists, Inc.

Sponsored By: Supervisor Holtz, Councilmember Kaminski

WHEREAS, New York Independent System Operator ("NYISO"), the operator of New York's electricity grid, supports demand support programs to deal with electricity demands during periods of high demand, and

WHEREAS, moneys are available through these programs to businesses that can reduce some or all of their electric requirements for a few hours a year when the electric grid is unstable through the "Operation Save New York" program, and

WHEREAS, the Town of Cheektowaga is committed to saving money by reducing the use of electricity at our facilities, and

WHEREAS, the Town of Cheektowaga previously, by Resolutions Nos. 2008-426 and 2008-499, executed enrollment forms with Energy Curtailment Specialists, Inc. ("ECS"), an administrator of the NYSIO, for the Town's Wastewater Pump Station and Stiglmeier Park, under this program, and has saved thousands of dollars each year, and

WHEREAS, ECS has requested the Town of Cheektowaga to renew its participation in this program, NOW, THEREFORE, BE IT

RESOLVED, that the Supervisor be and hereby is authorized and directed to execute an Renewal of Participation form with ECS.

RESULT:	ADOPTED [UNANIMOUS]
MOVER:	Mary Holtz, Supervisor
SECONDER:	Gerald Kaminski, Councilmember
AYES:	Holtz, Rogowski, Kaminski, Wozniak, Benczkowski, Meyers



8. RESOLUTION 2014-459

Authorize Supervisor to Execute Affiliation Agreement with Buffalo State College

Sponsored By: Councilmember Benczkowski, Councilmember Kaminski

WHEREAS, occasionally, students at local colleges wish to obtain unpaid internships with the Town of Cheektowaga in their fields of study, and

WHEREAS, the Town of Cheektowaga wishes to work with local colleges to enable students to obtain real life on-the-job training opportunities, and

WHEREAS, the State University of New York, Buffalo State College, wishes to offer this opportunity to their students, and

WHEREAS, the State University of New York, Buffalo State College, has submitted to the Town of Cheektowaga an Affiliation Agreement between said College and the Town of Cheektowaga for a program through the Town of Cheektowaga Police Department, and

WHEREAS, said agreement has been reviewed and approved as to form by the Town Attorney, NOW, THEREFORE, BE IT

RESOLVED, that the Supervisor be and hereby is authorized and directed to execute said Affiliation Agreement on behalf of the Town of Cheektowaga.

RESULT:	ADOPTED [UNANIMOUS]
MOVER:	Diane Benczkowski, Councilmember
SECONDER:	Gerald Kaminski, Councilmember
AYES:	Holtz, Rogowski, Kaminski, Wozniak, Benczkowski, Meyers



9. RESOLUTION 2014-460

Authorize Supervisor to Execute Affiliation Agreement with SUNYAB

Sponsored By: Councilmember Benczkowski, Councilmember Kaminski

WHEREAS, occasionally, students at local colleges wish to obtain unpaid internships with the Town of Cheektowaga in their fields of study, and

WHEREAS, the Town of Cheektowaga wishes to work with local colleges to enable students to obtain real life on-the-job training opportunities, and

WHEREAS, the State University of New York at Buffalo wishes to offer this opportunity to their students, and

WHEREAS, the State University of New York at Buffalo, has submitted to the Town of Cheektowaga an Affiliation Agreement between said College and the Town of Cheektowaga for a program through the Town of Cheektowaga Police Department, and

WHEREAS, said agreement has been reviewed and approved as to form by the Town Attorney, NOW, THEREFORE, BE IT

RESOLVED, that the Supervisor be and hereby is authorized and directed to execute said Affiliation Agreement on behalf of the Town of Cheektowaga.

RESULT:	ADOPTED [UNANIMOUS]
MOVER:	Diane Benczkowski, Councilmember
SECONDER:	Gerald Kaminski, Councilmember
AYES:	Holtz, Rogowski, Kaminski, Wozniak, Benczkowski, Meyers



10. RESOLUTION 2014-461

Authorize Supervisor to Execute Memorandum of Understanding with New York State Chiropractic College

Sponsored By: Councilmember Kaminski, Supervisor Holtz

WHEREAS, the New York State Education Law Article 129-A, Section 6434, directs each college in New York State to adopt and implement a plan providing for the investigation of any violent felony offense occurring at or on the grounds of each such institution, to provide for the investigation of reports of any missing students, and to provide for the coordination of the investigation of such crimes and reports with local law enforcement agencies; and

WHEREAS, the New York Chiropractic College Health Center ("NYCC"), located at 4974 Transit Road, Depew, New York, in order to maintain effective law enforcement and a secure environment, desires to provide all reasonable and appropriate support to the Cheektowaga Police Department and other law enforcement agencies who may be involved in the investigation of any alleged crime or other incident that may occur at the College Health Center or at housing owned or operated at the aforesaid location by NYCC; and

WHEREAS, the College has requested that the Town enter into a Memorandum of Understanding concerning the College's plan for the investigation of violent felonies or reports of missing students who reside in housing owned or operated at said location by NYCC; and

WHEREAS, NYCC has prepared and submitted a Memorandum of Understanding for such purpose; NOW, THEREFORE, BE IT

RESOLVED, that the Supervisor be and hereby is authorized to execute a Memorandum of Understanding with the New York Chiropractic College, subject to the approval of the Town Attorney.

RESULT:	ADOPTED [UNANIMOUS]
MOVER:	Gerald Kaminski, Councilmember
SECONDER:	Mary Holtz, Supervisor
AYES:	Holtz, Rogowski, Kaminski, Wozniak, Benczkowski, Meyers



11. RESOLUTION 2014-462

Retain Engineering Consultant to Prepare Sanitary Sewer Overflow Abatement Report

Sponsored By: Councilmember Kaminski, Supervisor Holtz

WHEREAS, in order to formulate a long term plan for the elimination of sanitary sewer wet weather overflows, the Town of Cheektowaga needs to retain an engineering consultant to prepare an engineering report for the abatement of sanitary sewer overflows in the Town's wastewater collection system in accordance with directives from the New York State Department of Environmental Conservation, and

WHEREAS, Nussbaumer & Clarke, Inc. has submitted a proposal to the Town of Cheektowaga to perform said report at an initial upset threshold cost (final cost to be determined after further review and investigation) not to exceed \$150,000.00 without further Town Board approval, and

WHEREAS, since Nussbaumer & Clarke, Inc. is fully familiar with the Town's sanitary sewer system, the Town Engineer has recommended that this Town Board retain Nussbaumer & Clarke, Inc. to prepare said report, NOW, THEREFORE, BE IT

RESOLVED, subject to review and approval of the Proposal for Professional Services prepared by Nussbaumer & Clarke, Inc., this Town Board hereby retains Nussbaumer & Clarke, Inc. to prepare the aforementioned report at an initial cost not to exceed \$150,000.000 without further Town Board authorization, and BE IT FURTHER

RESOLVED, that, upon approval of the form of the aforesaid proposal by the Town Attorney, the Supervisor be and hereby is authorized and directed to execute said proposal on behalf of the Town of Cheektowaga, and BE IT FURTHER

RESOLVED, that funding for said services shall be appropriated from budget line item number 255-8125-4581.

RESULT:	ADOPTED [UNANIMOUS]
MOVER:	Gerald Kaminski, Councilmember
SECONDER:	Mary Holtz, Supervisor
AYES:	Holtz, Rogowski, Kaminski, Wozniak, Benczkowski, Meyers



12. RESOLUTION 2014-463

Unsafe-Unsecured/2621 Genesee Street

Sponsored By: Supervisor Holtz, Councilmember Benczkowski

WHEREAS, Town of Cheektowaga Law for the Administration and Enforcement of the Codes of New York State; and the Property Maintenance Code of New York State require that all vacant structures and premises shall be maintained in clean, safe, secure and sanitary conditions so as not to cause a blighting problem or adversely affect the public health or safety and all nuisances abated, AND

WHEREAS, the Town of Cheektowaga has received notification of an unsafe structure and premises located at 2621 Genesee Street, Cheektowaga, New York SBL# 91.78-2-4 that is a danger to the safety of others, and records kept by the Assessors Office identify Frank Rodriquez, 2621 Genesee Street, Cheektowaga, New York 14225, as the owner AND

WHEREAS, an inspection of such premises was conducted at 2621 Genesee Street, by the Housing and Neighborhood Preservation Office, AND

WHEREAS, such inspection found the premises to be deteriorated, vacant, a hazard, and a danger to the safety and well being of others, AND

WHEREAS, the Town of Cheektowaga Housing and Neighborhood Preservation Office properly notified the property owner in accordance with the Town of Cheektowaga Law for the Administration and Enforcement of the Codes of New York State, and the owner failed to take actions to safeguard the premises, AND

WHEREAS, these conditions require the Town of Cheektowaga Housing and Neighborhood Preservation Office to take immediate steps to safeguard the premises to protect the health and safety of others and abate all nuisances, NOW, THEREFORE BE IT

RESOLVED, that pursuant to Section 70-7A.(5) and Section 70-8 of the Town of Cheektowaga Law for the Administration and Enforcement of the Codes of New York State that the vacant structure premises be safeguarded and all nuisances abated; and all costs incurred be assessed against the property hereinbefore described.

RESULT:	ADOPTED [UNANIMOUS]
MOVER:	Mary Holtz, Supervisor
SECONDER:	Diane Benczkowski, Councilmember
AYES:	Holtz, Rogowski, Kaminski, Wozniak, Benczkowski, Meyers



13. RESOLUTION 2014-464

Unsafe-Unsecured/16 A-D Glenwood Court

Sponsored By: Supervisor Holtz, Councilmember Benczkowski

WHEREAS, Town of Cheektowaga Law for the Administration and Enforcement of the Codes of New York State; and the Property Maintenance Code of New York State require that all vacant structures and premises shall be maintained in clean, safe, secure and sanitary conditions so as not to cause a blighting problem or adversely affect the public health or safety and all nuisances abated, AND

WHEREAS, the Town of Cheektowaga has received notification of an unsafe structure and premises located at 16 A-D Glenwood Court, Cheektowaga, New York SBL# 91.15-1-15 that is a danger to the safety of others, and records kept by the Assessors Office identify Louis Migliore, 1034 Amherst Street Buffalo, New York 14216, as the owner AND

WHEREAS, an inspection of such premises was conducted at 16 A-D Glenwood Court, by the Housing and Neighborhood Preservation Office, AND

WHEREAS, such inspection found the premises to be deteriorated, vacant, a hazard, and a danger to the safety and well being of others, AND

WHEREAS, the Town of Cheektowaga Housing and Neighborhood Preservation Office properly notified the property owner in accordance with the Town of Cheektowaga Law for the Administration and Enforcement of the Codes of New York State, and the owner failed to take actions to safeguard the premises, AND

WHEREAS, these conditions require the Town of Cheektowaga Housing and Neighborhood Preservation Office to take immediate steps to safeguard the premises to protect the health and safety of others and abate all nuisances, NOW, THEREFORE BE IT

RESOLVED, that pursuant to Section 70-7A.(5) and Section 70-8 of the Town of Cheektowaga Law for the Administration and Enforcement of the Codes of New York State that the vacant structure premises be safeguarded and all nuisances abated; and all costs incurred be assessed against the property hereinbefore described.

RESULT:	ADOPTED [UNANIMOUS]
MOVER:	Mary Holtz, Supervisor
SECONDER:	Diane Benczkowski, Councilmember
AYES:	Holtz, Rogowski, Kaminski, Wozniak, Benczkowski, Meyers



14. RESOLUTION 2014-465

Special Event - HSBC S Co-Ed Softball Tournament

Sponsored By: Councilmember Rogowski, Councilmember Meyers

WHEREAS, by resolution dated June 2, 2014, this Town Board approved a Special Event request for the HSBC Sports and Social Club for their annual "Co-Ed" Softball Tournament to be held on August 9, 2014; AND

WHEREAS, the HSBC Sports and Social Club has requested to reschedule this event to Saturday, September 13th, from 7:00 a.m. until 7:00 p.m. at Stiglmeier Park; NOW, THEREFORE BE IT

RESOLVED, that the HSBC Sports and Social Club "Co-Ed" Softball Tournament be and hereby is approved to be held on Saturday, September 13, 2014 from 7:00 a.m. until 7:00 p.m. at Stiglmeier Park.

RESULT:	ADOPTED [UNANIMOUS]
MOVER:	James P. Rogowski, Councilmember
SECONDER:	Timothy J. Meyers, Councilmember
AYES:	Holtz, Rogowski, Kaminski, Wozniak, Benczkowski, Meyers



15. RESOLUTION 2014-466

Bonfire-Cleveland Hill School

Sponsored By: Supervisor Holtz, Councilmember Benczkowski

WHEREAS, pursuant to the Open Burning Law of the Town of Cheektowaga, the Fire Inspector reviews various applications for open fires and open burning and renders his recommendation concerning the fire safety and impact to the general public of such application, AND

WHEREAS, the Town Board, pursuant to the Open Burning Law of the Town of Cheektowaga, is designated the Approval Agency, AND

WHEREAS, since the Town Board is the Approval Agency, it must affirm, modify or reject any recommendations or permits submitted to it by the Town Fire Inspector, AND

WHEREAS, an application for a permit was submitted by the Cleveland Hill Union Free School District to conduct a open fire on October 3, 2014 on the property located at 105 Mapleview Road, Cheektowaga, New York AND

WHEREAS, the applicant intends to maintain a small bonfire with the assistance of the Cleveland Hill Fire Department in conjunction with summer youth activities, AND

WHEREAS, the Fire Inspector Joseph Ehnes has received this application and finds that all requirements have been met. And that this application is in compliance with conditions and requirement of the Town of Cheektowaga Fire Prevention Code and the Open Burning Law. He requests the Town Board approve issuance of a permit, AND

WHEREAS, this Town Board has reviewed the application submitted by the Cleveland Hill Union Free School District and the recommendations of the Fire Inspector Joseph Ehnes, NOW, THEREFORE, BE IT

RESOLVED, that this Town Board, authorizes the Fire Inspector Joseph Ehnes to issue such permit.

RESULT:	ADOPTED [UNANIMOUS]
MOVER:	Mary Holtz, Supervisor
SECONDER:	Diane Benczkowski, Councilmember
AYES:	Holtz, Rogowski, Kaminski, Wozniak, Benczkowski, Meyers



16. RESOLUTION 2014-467

Hiring/Termination of Part Time Employees

Sponsored By: Councilmember Kaminski, Supervisor Holtz

BE IT RESOLVED, that the following individual be and hereby is hired as a **PART-TIME EMPLOYEE** in the department listed, not to exceed nineteen (19) hours on a weekly basis, in compliance with Civil Service Laws and Regulations as well as the provisions of the Town's collective bargaining agreement between the Town of Cheektowaga and the Town of Cheektowaga Employees Association:

BUILDING AND PLUMBING DEPARTMENT Clerk (Temporary) \$8.75/hour effective 8/19/14
Matthew J. Greenberg, Cheektowaga, New York

BE IT RESOLVED, that the following seasonal and/or part-time employees be and hereby are terminated as listed:

EMPLOYEE RELATIONS

Anthony M. Romano effective 8/8/14

POLICE DEPARTMENT

Jenna N. Hockwater effective 8/20/14

SENIOR SERVICES

Mildred Fournier effective 8/19/14

Motion by Councilmember Rogowski; Seconded by Councilmember Meyers to Waive the Reading of Names for this Resolution. Motion Carried.

RESULT: ADOPTED [UNANIMOUS]
MOVER: Gerald Kaminski, Councilmember
SECONDER: Mary Holtz, Supervisor
AYES: Holtz, Rogowski, Kaminski, Wozniak, Benczkowski, Meyers



17. RESOLUTION 2014-468

Termination of Park Maintenance Worker I (Mark M. Blachowicz)

Sponsored By: Supervisor Holtz, Councilmember Kaminski

BE IT RESOLVED, that Park Maintenance Worker I Mark M. Blachowicz is hereby terminated effective August 15, 2014.

RESULT:	ADOPTED [UNANIMOUS]
MOVER:	Mary Holtz, Supervisor
SECONDER:	Gerald Kaminski, Councilmember
AYES:	Holtz, Rogowski, Kaminski, Wozniak, Benczkowski, Meyers



18. RESOLUTION 2014-469

Travel Authorization Police Department/Detective Timothy Szymanski

Sponsored By: Councilmember Benczkowski, Councilmember Kaminski

WHEREAS, the Certified SABIS/Latent Print Examiner: Level III Seminar is being held September 22 through September 26, 2014 in Albany, New York; AND

WHEREAS, Detective Timothy Szymanski has been recommended to attend said seminar; AND

WHEREAS, Police Chief David Zack has submitted a request for travel authorization along with the proper paperwork in a timely manner; AND

WHEREAS, the total cost to the Town shall not exceed \$696; AND

WHEREAS, these expenses have been budgeted by the Department; NOW, THEREFORE, BE IT

RESOLVED, that Detective Timothy Szymanski be and hereby is authorized to attend the Certified SABIS/Latent Print Examiner: Level III Seminar being held September 22 through September 26, 2014 in Albany, New York.

RESULT:	ADOPTED [UNANIMOUS]
MOVER:	Diane Benczkowski, Councilmember
SECONDER:	Gerald Kaminski, Councilmember
AYES:	Holtz, Rogowski, Kaminski, Wozniak, Benczkowski, Meyers



19. RESOLUTION 2014-470

Travel Authorization Community Development/Richard J. Willis

Sponsored By: Councilmember Kaminski, Supervisor Holtz

WHEREAS, the Asbestos Project Designer Course is being held August 18 through August 20, 2014 in Buffalo, New York; AND

WHEREAS, Assistant Code Enforcement Officer Richard J. Willis has been recommended to attend said course; AND

WHEREAS, Director of Community Development Carla Kosmerl has submitted a request for travel authorization along with the proper paperwork in a timely manner; AND

WHEREAS, the total cost to the Town shall not exceed \$620; AND

WHEREAS, these expenses have been budgeted by the Department; NOW, THEREFORE, BE IT

RESOLVED, that Assistant Code Enforcement Officer Richard J. Willis be and hereby is authorized to attend the Asbestos Project Designer Course being held August 18 through August 20, 2014 in Buffalo, New York.

RESULT:	ADOPTED [UNANIMOUS]
MOVER:	Gerald Kaminski, Councilmember
SECONDER:	Mary Holtz, Supervisor
AYES:	Holtz, Rogowski, Kaminski, Wozniak, Benczkowski, Meyers

IV. Communications

A. Departmental Communications

1. **Minutes: Cheektowaga Conservation Advisory Council - June 5, 2014**
2. **Notice of Closure of Rein Road Bridge in the Town of Cheektowaga shall be closed to vehicular and pedestrian traffic beginning August 18, 2014 and continuing until December 15, 2014.**

B. General Communications

1. **Notice of Claim: Veronica K. Brown vs. Town of Cheektowaga**

2. Notice of Claim: Judith A. Edmister vs. Town of Cheektowaga
3. Notice of Claim: Marilyn Y. Hubbard vs. Town of Cheektowaga
4. Notice of Claim: Jeff Kerl vs. Town of Cheektowaga
5. Notice of Claim: Brittany Kullewicz vs. Town of Cheektowaga
6. Notice of Claim: Judith M. Mahalic vs. Town of Cheektowaga
7. Notice of Claim: Mary & Thomas Walsh vs. Town of Cheektowaga
8. Notice of Petition: EPK Properties, LLC vs. Assessor for theTown of Cheektowaga; The Board of Assessment Review for the Town of Cheektowaga and the Town of Cheektowaga, in the County of Erie, New York
9. Notice of Petition: Joseph R. LaJudice vs. Assessor for theTown of Cheektowaga; The Board of Assessment Review for the Town of Cheektowaga and the Town of Cheektowaga, in the County of Erie, New York
10. Notice of Petition: 2060 Auto Parks, Inc and 2150 Recycling Center, Inc. vs. Assessor for theTown of Cheektowaga; The Board of Assessment Review for the Town of Cheektowaga and the Town of Cheektowaga, in the County of Erie, New York
11. Notice of Petition: Western New York Business Ventures, Inc. vs. Assessor for theTown of Cheektowaga; The Board of Assessment Review for the Town of Cheektowaga and the Town of Cheektowaga, in the County of Erie, New York
12. Petition from Homeowners/Residents of Roycroft Blvd. RE: Winter Plowing
13. Petition from Residents on Lordan Drive

V. Comments

A. Supervisor's Comments

B. Councilmember's Comments

C. Public Comments

VI. Adjournment

Motion by Supervisor Holtz; Seconded by Councilmember Rogowski to adjourn the meeting in memory of James Speyer, Sr.; Member of the Zoning Board and J. Donald Griffin/ former POW and member of Veterans' Committee. Time: 7:19PM

Alice Magierski, Town Clerk

VII. Presentation

Buffalo Crushed Stone and Dan Ulatowski, Town Planner.



Town of Cheektowaga

Regular Meeting

~ Minutes ~

3301 Broadway
Cheektowaga, NY 14227
<http://www.town.cheektowaga.ny.us>

Alice Magierski
716-686-3400

Tuesday, September 2, 2014

6:45 PM

Council Chambers

I. Call to Order

6:45 PM Meeting called to order on September 2, 2014 at Council Chambers, 3301 Broadway St, Cheektowaga, NY.

Attendee Name	Organization	Title	Status	Arrived
Mary Holtz	Town of Cheektowaga	Supervisor	Present	
James P. Rogowski	Town of Cheektowaga	Councilmember	Present	
Gerald Kaminski	Town of Cheektowaga	Councilmember	Present	
Angela M. Wozniak	Town of Cheektowaga	Councilmember	Present	
Diane Benczkowski	Town of Cheektowaga	Councilmember	Present	
Timothy J. Meyers	Town of Cheektowaga	Councilmember	Present	

2. Additional Attendees

Patrick Bowen, Town Engineer
Carla A. Kosmerl, Director of Community Development
Brian Krause, Director of Finance and Administration
Karen Marchese, Coordinator of Employee Relations
Kevin Schenk, Town Attorney

II. Public Comment Period

III. Resolutions



1. RESOLUTION 2014-471

Transfer of Funds

Sponsored By: Supervisor Holtz, Councilmember Kaminski

BE IT RESOLVED, that the following transfer is hereby approved and made part hereof;

GENERAL FUND

FROM:	100.3120.3820	STATE AID POLICE	\$ 1,671.00
TO:	100.3120.4003	TRAFFIC SAFETY SUPPLIES	\$ 1,671.00

SPECIAL DISTRICTS FUND

FROM:	255.8125.4543	CONTRACTED SEWER REPAIRS	\$ 25,000.00
TO:	255.8125.4581	CONSULTING ENGINEERS	\$ 25,000.00

RESULT:	ADOPTED [UNANIMOUS]
MOVER:	Mary Holtz, Supervisor
SECONDER:	Gerald Kaminski, Councilmember
AYES:	Holtz, Rogowski, Kaminski, Wozniak, Benczkowski, Meyers



2. RESOLUTION 2014-472

Warrant

Sponsored By: Supervisor Holtz, Councilmember Kaminski

BE IT RESOLVED, that the following Vouchers & Warrants submitted to the Town of Cheektowaga prior to August 29, 2014 are hereby approved and made part hereof;

GENERAL FUND	\$ 4,586,740.28
RISK RETENTION FUND	1,112,494.66
DEBT	28,664,499.97
SPECIAL DISTRICTS FUND	808,252.50
HIGHWAY FUND	1,274,871.05
CAPITAL FUND	308,827.94
TRUST & AGENCY FUND	7,881.99
HUD CDBG FUND	5,150.52
PART TOWN FUND	147,421.97
	<hr/>
	\$ 36,916,140.88

RESULT:	ADOPTED [UNANIMOUS]
MOVER:	Mary Holtz, Supervisor
SECONDER:	Gerald Kaminski, Councilmember
AYES:	Holtz, Rogowski, Kaminski, Wozniak, Benczkowski, Meyers



3. RESOLUTION 2014-473

Amend Resolution Relating to Grant Application

Sponsored By: Councilmember Benczkowski, Councilmember Kaminski

WHEREAS, by resolution dated July 21, 2014 (Resolution 2014-421), this Town Board authorized the application for grant funding for the Police Department through the FY2014 Technical Rescue and Urban Search and Rescue Grant Program from the New York State Division of Homeland Security and Emergency Services Office of Counter Terrorism, and

WHEREAS, an error was made in the name of the grant program; the technical correct name of this grant is FY14 Tactical Team Targeted Grant Program, and

WHEREAS, funding is available through the FY14 Tactical Team Targeted Grant Program for body armor and helmets, NOW, THEREFORE, BE IT

RESOLVED, that the aforementioned Resolution 2014-421 be and hereby is amended to direct KEHEOPS, the Town's grants consultants, to apply for funding for the Cheektowaga Police Department under the FY14 Tactical Team Targeted Grant Program, and BE IT FURTHER

RESOLVED, that the Supervisor be and hereby is authorized and directed to execute all documents pertaining to the application and acquisition of funding under said grant.

RESULT:	ADOPTED [UNANIMOUS]
MOVER:	Diane Benczkowski, Councilmember
SECONDER:	Gerald Kaminski, Councilmember
AYES:	Holtz, Rogowski, Kaminski, Wozniak, Benczkowski, Meyers



4. RESOLUTION 2014-474

Negative SEQR Declaration - 4243-4271 Genesee Street Starbucks Coffee

Sponsored By: Councilmember Meyers, Supervisor Holtz

WHEREAS, pursuant to the Environmental Impact Review Ordinance of the Town of Cheektowaga, the Environmental Advisory Committee ("EAC") reviews various applications for site plans, rezonings, special permits, etc. And renders its recommendation concerning the environmental significance of such application, AND

WHEREAS, an application was submitted by Benderson Development Co., LLC for the construction of a 9,800 sf retail building at 4243-4271 Genesee Street which will accommodate a 1,950 sf Starbucks Coffee shop with an accessory drive through window, AND

WHEREAS, the proposed accessory drive through window requires a special use permit and relief from the accessory drive through provisions of the Zoning Law of the Town of Cheektowaga, AND

WHEREAS, the Town Board, pursuant to the Environmental Impact Review Ordinance of the Town of Cheektowaga, is designated the Lead Agency, AND

WHEREAS, since the Town Board is the Lead Agency, it must affirm, modify or reject any recommendations submitted to it by the Advisory Committee, AND

WHEREAS, the Town of Cheektowaga Planning Board recommended approval of the site plan at their meeting of June 12, 2014, AND

WHEREAS, the Town of Cheektowaga Traffic Safety Commission has reviewed the subject project and is recommending its approval, AND

WHEREAS, the Environmental Advisory Committee at its meetings held on August 20, 2014 recommended a SEQR determination of non significance, AND

WHEREAS, this Town Board has reviewed the application submitted and the recommendations made by the Environmental Advisory Committee, the Planning Board and the Traffic Safety Commission, NOW, THEREFORE, BE IT

RESOLVED, that this Town Board determines that the project will not have a significant effect on the environment and therefore issues a Negative Declaration for purposes of the State Environmental Quality Review Act (SEQRA).

RESULT:	ADOPTED [UNANIMOUS]
MOVER:	Timothy J. Meyers, Councilmember
SECONDER:	Mary Holtz, Supervisor
AYES:	Holtz, Rogowski, Kaminski, Wozniak, Benczkowski, Meyers



5. RESOLUTION 2014-475

Accept Site Plan- 4243-4271 Genesee Street Starbucks Coffee

Sponsored By: Councilmember Benczkowski, Councilmember Rogowski

WHEREAS, pursuant to the Zoning Law of the Town of Cheektowaga, the Planning Board reviews various development review applications for site plans, rezonings, special permits and realty subdivisions and renders its recommendation concerning the compatibility of such application with the zoning regulations, the Town Master Plan and neighborhood character, AND

WHEREAS, the Town Board, pursuant to section 260-47.1C of the Zoning Law of the Town of Cheektowaga is vested with the authority to approve site plans and modify or reject any recommendation submitted to it by its advisory committees, AND

WHEREAS, Benderson Development Co., LLC submitted a development review application for the construction of a 9,800 sf retail building at 4243-4271 Genesee Street which will accommodate a 1,950 sf Starbucks Coffee shop with an accessory drive through window, AND

WHEREAS, the Town of Cheektowaga Planning Board, reviewed and commented on the Application at their meeting of June 12, 2014 and have recommended approval thereof, NOW THEREFORE BE IT,

RESOLVED, that pursuant to Section 260-47-1 of the Code of the Town of Cheektowaga and Section 274-a of New York State Town Law that this Town Board approves the proposed site plan subject to:

1. The Town Engineer reviewing and approving the grading/drainage plan.

RESULT:	ADOPTED [UNANIMOUS]
MOVER:	Diane Benczkowski, Councilmember
SECONDER:	James P. Rogowski, Councilmember
AYES:	Holtz, Rogowski, Kaminski, Wozniak, Benczkowski, Meyers



6. RESOLUTION 2014-476

Approve Special Use Permit & Variance - 4243-4271 Genesee Street

Sponsored By: Councilmember Benczkowski, Councilmember Meyers

WHEREAS, Benderson Development Company, LLC has applied for a Special Use Permit to establish an accessory drive through window for a proposed restaurant/cafe on property owned by 4243 GS Associates, LLC and located at 4243-4271 Genesee Street, Cheektowaga, New York, pursuant to Sections 260-47 and 260-48.2 of the Code of the Town of Cheektowaga ("Zoning Law"); and

WHEREAS, Benderson Development Company, LLC also requested a variance to reduce the number of vehicle queues from sixteen (16) to eleven (11), and

WHEREAS, a public hearing was held before the Cheektowaga Town Board on the 4th day of August, 2014 at 6:45 P.M. of said day for the purpose of considering said applications for a Special Permit and variances from the Zoning Law, after publication and service of the notices required by the provisions of the Zoning Law and the Town Law; and all interested parties were given an opportunity to be heard at such hearing; and

WHEREAS, the Cheektowaga Planning Board has recommended approval of this Special Permit and variance; and

WHEREAS, this Town Board previously issued a Negative Declaration under SEQRA for this project; NOW, THEREFORE BE IT

RESOLVED, that the aforesaid Special Use Permit be and hereby is granted, and BE IT FURTHER

RESOLVED, that this Town Board hereby grants the aforementioned variance relating to the reduction in the vehicle queue from sixteen (16) to eleven (11).

RESULT:	ADOPTED [UNANIMOUS]
MOVER:	Diane Benczkowski, Councilmember
SECONDER:	Timothy J. Meyers, Councilmember
AYES:	Holtz, Rogowski, Kaminski, Wozniak, Benczkowski, Meyers



7. RESOLUTION 2014-477

Call for Public Hearing - 4213 Genesee Street S&K Hotels, LLC

Sponsored By: Councilmember Benczkowski, Councilmember Rogowski

WHEREAS, S&K Hotels, LLC has made application and requested a special use permit to establish a car rental agency at 4213 Genesee Street, NOW, THEREFORE BE IT

RESOLVED, that a Public Hearing be held regarding said request under the provisions of the Zoning Law on September 15th, 2014 at 6:45 P.M., at the Cheektowaga Town Hall, 3301 Broadway at the corner of Union Road.



Notice of Public Hearing

NOTICE IS HEREBY GIVEN that a Public Hearing will be held by the Town Board of the Town of Cheektowaga, Erie County, New York at the Town Hall in the said Town of Cheektowaga, 3301 Broadway corner of Union Road on the September 15th, 2014 at 6:45 o'clock P.M., of said day for the purpose of considering the application of:

S&K Hotels, LLC

Requesting a special use permit to establish a car rental agency at 4213 Genesee Street.

All parties in interest and citizens will be given an opportunity to be heard in regard to such proposed application.

BY ORDER OF THE TOWN BOARD, Town of Cheektowaga, NY

Alice Magierski, TOWN CLERK



All that tract or parcel of land situate in Town of Cheektowaga, County of Erie, and State of New York, being part of Lot No. 5, Township 11, Range 7 of the Holland Land Company's Survey, bounded and described as follows: Beginning at the point of intersection of the southerly boundary of Genesee Street as established by virtue of Notice of Appropriation recorded in Erie County Clerk's Office in Liber 7600 of Deeds at page 54 and identified therein as Map No. 29, Parcel No. 30 with the division line between the property now or formerly of Dynamic Hotel Development, Inc. on the east and the property of NLChemicals/NL Industries on the west, said division line being established by Boundary Line Agreement recorded in Erie County Clerk's Office in Liber 6666 of Deeds at page 587, said beginning point being 2343.16 feet east of the west line of Lot No. 5; running thence easterly along said southerly boundary of Genesee Street 23.04 feet to the northeast corner of a parcel of land appropriated by the People of the State of New York by Notice of Appropriation recorded in Erie County Clerk's Office in Liber 11070 of Deeds at page 7337 and identified therein as Map No. 282, Parcel No. 325; thence southwesterly and southerly along the present right of way of said Map 282, Parcel

325, the following bearings and distances: S 56° 02' 50" W, 15.83 feet to a point; S 13° 58' 08" W, 220.41 feet to the principal point of beginning; running thence easterly bearing S 75° 05' 18" E, 164.47 feet to a point; thence southerly bearing S 14° 42' 02" W, 21.64 feet to a point; thence westerly and bearing N 75° 17' 58" W, 45.50 feet to a point; thence southerly and bearing S 14° 42' 02" W, 85.78 feet to a point; thence westerly and bearing N 75° 17' 58" W, 1.10 feet to a point; thence southerly and bearing S 14° 42' 02" W, 2 feet to a point; thence easterly and bearing S 75° 17' 58" E, 1.10 feet to a point; thence southerly and bearing S 14° 42' 02" W, 16.10 feet to a point; thence easterly and bearing S 75° 05' 18" E, 50.64 feet to a point; thence southerly and bearing S 14° 42' 02" W a distance of 109.52 feet to a point; thence westerly and bearing N 75° 05' 18" W, 166.52 feet to a point; thence N 13° 58' 08" E 241.53 to the principal point of beginning.

RESULT:	ADOPTED [UNANIMOUS]
MOVER:	Diane Benczkowski, Councilmember
SECONDER:	James P. Rogowski, Councilmember
AYES:	Holtz, Rogowski, Kaminski, Wozniak, Benczkowski, Meyers



8. RESOLUTION 2014-478

Call for Public Hearing - 93 Maryvale Drive T-Mobile Northeast , LLC

Sponsored By: Councilmember Benczkowski, Councilmember Rogowski

WHEREAS, T-Mobile Northeast, LLC has made application and requested a special use permit for co-locating a new cellular communications facility on an existing 139 foot tall cell tower at 93 Maryvale Drive, NOW, THEREFORE BE IT

RESOLVED, that a Public Hearing be held regarding said request under the provisions of the Zoning Law on September 15th, 2014 at 6:45 P.M., at the Cheektowaga Town Hall, 3301 Broadway at the corner of Union Road.



Notice of Public Hearing

NOTICE IS HEREBY GIVEN that a Public Hearing will be held by the Town Board of the Town of Cheektowaga, Erie County, New York at the Town Hall in the said Town of Cheektowaga, 3301 Broadway corner of Union Road on the September 15th, 2014 at 6:45 o'clock P.M., of said day for the purpose of considering the application of:

T-Mobile Northeast, LLC

For a special use permit for co-locating a new cellular communications facility on an existing 139 foot tall cell tower at 93 Maryvale Drive,

All parties in interest and citizens will be given an opportunity to be heard in regard to such proposed application.

BY ORDER OF THE TOWN BOARD, Town of Cheektowaga, NY

Alice Magierski, TOWN CLERK



All that tract or parcel of land situate in Town of Cheektowaga, County of Erie, and State of New York, being part of Lot No. 35, Township 11, Range 7 of the Holland Land Company's Survey, described as follows:

BEGINNING at a point in the southerly line of Maryvale Drive (formerly Pine Ridge Road) distant 160 feet west from the east line of Lot No. 35, said east line of Lot No. 35, being also the west line of Harlem Road as laid out as a 66 foot highway; thence southerly parallel with the east line of Lot No. 35 a distance of 175 feet to a point; thence westerly parallel with

Maryvale Drive, a distance of 90 feet to a point; thence northerly parallel with the east line of Lot No. 35 a distance of 175 feet to a point in the southerly line of Maryvale Drive; thence easterly along the southerly line of Maryvale Drive 90 feet to the point or place of beginning.

RESULT:	ADOPTED [UNANIMOUS]
MOVER:	Diane Benczkowski, Councilmember
SECONDER:	James P. Rogowski, Councilmember
AYES:	Holtz, Rogowski, Kaminski, Wozniak, Benczkowski, Meyers



9. RESOLUTION 2014-479

Call for Public Hearing - 2700 Union Road Rerob, LLC- Express Mart

Sponsored By: Councilmember Benczkowski, Councilmember Rogowski

WHEREAS, Carmina Wood Morris, DPC with permission of the owner, Rerob, LLC has made application and requested the rezoning of 2700 Union Road from CM- General Commercial to MS- Motor service, as well as, a request for a special use permit for an accessory drive through window for a proposed 5,256 sf convenience store with an accessory coffee /donut shop, NOW, THEREFORE BE IT

RESOLVED, that a Public Hearing be held regarding said request under the provisions of the Zoning Law on September 15th, 2014 at 6:45 P.M., at the Cheektowaga Town Hall, 3301 Broadway at the corner of Union Road.



Notice of Public Hearing

NOTICE IS HEREBY GIVEN that a Public Hearing will be held by the Town Board of the Town of Cheektowaga, Erie County, New York at the Town Hall in the said Town of Cheektowaga, 3301 Broadway corner of Union Road on the September 15th, 2014 at 6:45 o'clock P.M., of said day for the purpose of considering the application of:

Carmina Wood Morris, DPC

Requesting the rezoning of 2700 Union Road from CM- General Commercial to MS- Motor service, as well as, a request for a special use permit for an accessory drive through window for a proposed 5,256 sf convenience store with an accessory coffee /donut shop.

All parties in interest and citizens will be given an opportunity to be heard in regard to such proposed application.

BY ORDER OF THE TOWN BOARD, Town of Cheektowaga, NY

Alice Magierski, TOWN CLERK



All that tract or parcel of land situate in Town of Cheektowaga, County of Erie, and State of New York, being part of Lot No.64, Township 10, Range 7 of the Buffalo Creek Reservation, described as follows:

BEGINNING at a point on the northerly highway boundary of William Street (Eighme Road) (County Road No. 207) as acquired by the Erie County Department of Public Works in connection with the rebuilding of said William Street, at its intersection with the easterly line of lands described in a deed to Iroquois Gas Corporation by deed recorded in the Erie County Clerk's Office in Liber 2077 of Deeds at page 543, said point of beginning being also the northwesterly corner of Map No. 197-48R, Parcel 40 as shown on the said highway

appropriations; running thence north 00° 47' 47" east along the easterly line of the said Iroquois Gas Corporation lands, a distance of 85.19 feet to the northeast corner thereof; running thence north 89° 12' 13" west, along the northerly line of the Iroquois Gas Corporation lands, a distance of 25 feet to the northwesterly corner thereof; running thence north 00° 47' 47" east, parallel with the original center line of Union Road, a distance of 228.55 feet to a point, said point being the southwesterly corner of lands described in a deed to Matthew and Irene Korpanty by deed recorded in the Erie County Clerk's Office in Liber 7938 of Deeds at page 229; running thence south 87° 47' 55" east, along the southerly line of the said Korpanty lands and said line extended, a distance of 295.48 feet to a point on the westerly line of Union Road (Gardenville-Williamsville Part 1 (S.H. No. 1733) as acquired by New York State Department of Public Works Map No. 89, Parcel No. 99; running thence southerly along the westerly line of Union Road, Map No. 89, Parcel No. 99 on a curve to the left having a radius of 2,914.79 feet, a distance of 99.28 feet to a point; running thence south 22° 45' 54" west along the westerly line of Union Road, Map No. 89, Parcel no. 99, a distance of 72.70 feet to the northerly line of William Street; running thence south 61° 03' 49" west along the northerly line of William Street and the northerly line of Map No. 89, Parcel No. 99 and Map No. 88, Parcel No. 98 as acquired by New York State Department of Public Works, a distance of 85.90 feet to the northwest corner of Map No. 88, Parcel No. 98; running thence south 28° 56' 11" east along the westerly line of Map No. 88, Parcel No. 98, a distance of 11 feet to a point on the northerly line of William Street; running thence south 61° 03' 49" west along the northerly line of William Street, a distance of 141.54 feet to the southeast corner of Map No. 197-48R, Parcel 40 as acquired by the Erie County Department of Public Works in connection with the rebuilding of William Street; running thence north 30° 08' 12" west, along the easterly line of said Map No. 197-48R, Parcel 40, a distance of 10.88 feet to the northeast corner of said parcel; running thence south 61° 03' 49" west, along the northerly line of said parcel, a distance of 54.02 feet to the point or place of beginning.

RESULT:	ADOPTED [UNANIMOUS]
MOVER:	Diane Benczkowski, Councilmember
SECONDER:	James P. Rogowski, Councilmember
AYES:	Holtz, Rogowski, Kaminski, Wozniak, Benczkowski, Meyers



10. RESOLUTION 2014-480

Call for Public Hearing - 2013 Walden Avenue Panera Bread

Sponsored By: Councilmember Benczkowski, Councilmember Rogowski

WHEREAS, Benderson Development Co., LLC has made application and requested a special use permit for an accessory drive through window, as well as, relief from the regulations governing accessory drive through windows, for a proposed restaurant at 2013 Walden Avenue, , NOW, THEREFORE BE IT

RESOLVED, that a Public Hearing be held regarding said request under the provisions of the Zoning Law on September 15th, 2014 at 6:45 P.M., at the Cheektowaga Town Hall, 3301 Broadway at the corner of Union Road.

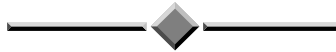

Notice of Public Hearing

NOTICE IS HEREBY GIVEN that a Public Hearing will be held by the Town Board of the Town of Cheektowaga, Erie County, New York at the Town Hall in the said Town of Cheektowaga, 3301 Broadway corner of Union Road on the September 15th, 2014 at 6:45 o'clock P.M., of said day for the purpose of considering the application of:

Benderson Development Co., LLC

For a special use permit for an accessory drive through window, as well as, relief from the regulations governing accessory drive through windows, for a proposed restaurant at 2013 Walden Avenue

All parties in interest and citizens will be given an opportunity to be heard in regard to such proposed application.

BY ORDER OF THE TOWN BOARD, Town of Cheektowaga, NY

Alice Magierski, TOWN CLERK



All That Tract Or Parcel Of Land Situate In Town Of Cheektowaga, County Of Erie, And State Of New York, In Part Of Town Lot 16, Township 11, Range 7, Part Of The Holland Land Company's Survey, Town Of Cheektowaga, County Of Erie, State Of New York, And Being More Particularly Bounded And Described As Follows:

Beginning At A Point On The West Right-Of-Way Line Of Duke Road (65' Wide) At The Southeast Corner Of Lands Now Or Formerly Owned By Wegmans Food Markets Inc, Described In Liber 10049 Of Deeds At Page 275 (Tax Account Number 102.04-01-017.10), Said Point Also Being The Northeast Corner Of Lands Now Or Formerly Owned By Cedar Key Associates, L.P. Described In Liber 10884 Of Deeds At Page 3917 (Tax Account Number 120.04-01-30.111); Thence

N87°11'44"W, A Distance Of 1,079.33 Feet To A Point On The Easterly Right-Of-Way Line Of

New York State Thruway Ontario Section; Thence

N02°00'21"E, And Along Said Easterly Right-Of-Way Line Of The New York State Thruway Ontario Section A Distance Of 180.73 Feet To A Point; Thence

N18°42'00"E, And Along Said Easterly Right-Of-Way Line Of The New York State Thruway Ontario Section A Distance Of 209.00 Feet To A Point; Thence

N47°37'00"E, And Along Said Easterly Right-Of-Way Line Of The New York State Thruway Ontario Section A Distance Of 187.40 Feet To A Point; Thence

N57°00'21"E, And Along Said Easterly Right-Of-Way Line Of The New York State Thruway Ontario Section A Distance Of 418.77 Feet To A Point; Thence

N02°00'21"E, And Along Said Easterly Right-Of-Way Line Of The New York State Thruway Ontario Section A Distance Of 593.44 Feet To A Point; Thence

N27°35'19"E, And Along Said Easterly Right-Of-Way Line Of The New York State Thruway Ontario Section A Distance Of 97.56 Feet To A Point On The Southerly Right-Of-Way Line Of Walden Avenue; Thence

S84°47'00"E, And Along Said Southerly Right-Of-Way Line Of Walden Avenue A Distance Of 316.50 Feet To A Point; Thence

S78°30'00"E, And Along Said Southerly Right-Of-Way Line Of Walden Avenue A Distance Of 152.12 Feet To A Point On The Westerly Right-Of-Way Line Of Duke Road; Thence

S00°37'04"W, Along Said Southerly Right-Of-Way Line Of Duke Road A Distance Of 1,406.28 Feet To The Point And Place Of Beginning. Containing 23.975 Acres Of Land, More Or Less.

RESULT:	ADOPTED [UNANIMOUS]
MOVER:	Diane Benczkowski, Councilmember
SECONDER:	James P. Rogowski, Councilmember
AYES:	Holtz, Rogowski, Kaminski, Wozniak, Benczkowski, Meyers



11. RESOLUTION 2014-481

Settlement of Claim - M.K.S. Plumbing Corporation

Sponsored By: Supervisor Holtz, Councilmember Kaminski

WHEREAS, the Town of Cheektowaga entered into and Agreement dated September 7, 2010 with M.K.S. Plumbing Corporation ("MKS") for Plumbing work for the Police & Court Building Renovations and Addition Project, and

WHEREAS, there were delays in completing said project, and

WHEREAS, MKS submitted a claim for additional compensation allegedly due because of the delay, and

WHEREAS, the law firm of Hodgson Russ LLP (William A. Lundquist, of Counsel), the Town Attorney and representatives of the Town of Cheektowaga met with representatives of MKS to reach a settlement on this claim, and have recommended to this Town Board a settlement with MKS, NOW, THEREFORE, BE IT

RESOLVED, that this Town Board hereby approves of the Settlement Agreement with MKS on this matter, and BE IT FURTHER

RESOLVED, that the Supervisor be and hereby is authorized and directed to execute said Settlement Agreement with MKS on behalf of the Town of Cheektowaga, and BE IT FURTHER

RESOLVED, that funds necessary to be paid to MKS for said settlement shall be appropriated from budget line item number 500.1440.25.28.5025.

RESULT:	ADOPTED [UNANIMOUS]
MOVER:	Mary Holtz, Supervisor
SECONDER:	Gerald Kaminski, Councilmember
AYES:	Holtz, Rogowski, Kaminski, Wozniak, Benczkowski, Meyers



12. RESOLUTION 2014-482

Settlement of Claim - MLP Plumbing & Mechanical, Inc.

Sponsored By: Supervisor Holtz, Councilmember Kaminski

WHEREAS, the Town of Cheektowaga entered into and Agreement dated September 7, 2010 with MLP Plumbing & Mechanical, Inc. ("MLP") for HVAC work for the Police & Court Building Renovations and Addition Project, and

WHEREAS, there were delays in completing said project, and

WHEREAS, MLP submitted a claim for additional compensation allegedly due because of the delay, and

WHEREAS, the law firm of Hodgson Russ LLP (William A. Lundquist, of Counsel), the Town Attorney and representatives of the Town of Cheektowaga met with representatives of MLP to reach a settlement on this claim, and have recommended to this Town Board a settlement with MLP, NOW, THEREFORE, BE IT

RESOLVED, that this Town Board hereby approves of the Settlement Agreement with MLP on this matter, and BE IT FURTHER

RESOLVED, that the Supervisor be and hereby is authorized and directed to execute said Settlement Agreement with MLP on behalf of the Town of Cheektowaga, and BE IT FURTHER

RESOLVED, that funds necessary to be paid to MLP for said settlement shall be appropriated from budget line item number 500.1440.2528.5025.

RESULT:	ADOPTED [UNANIMOUS]
MOVER:	Mary Holtz, Supervisor
SECONDER:	Gerald Kaminski, Councilmember
AYES:	Holtz, Rogowski, Kaminski, Wozniak, Benczkowski, Meyers



13. RESOLUTION 2014-483

Direct the Supervisor to Sign Public Utility Work Agreement Form HC-140

Sponsored By: Councilmember Meyers, Supervisor Holtz

WHEREAS, the New York State Department of Transportation proposes the November 2014 project letting for the milling and asphalt overlay of Walden Avenue from Union Road easterly to the CSX Overpass (BIN 7327170), identified as PIN 5812.54, AND

WHEREAS, as part of said highway rehabilitation project there is a need to perform adjustments and modifications to Town sanitary sewer district facilities located within the State highway right-of-way, NOW, THEREFORE, BE IT

RESOLVED, that this Town Board, in its capacity as the Board of Managers for the Town Consolidated Sanitary Sewer District, hereby grants permission to the NYSDOT to perform the necessary modifications to sanitary sewer district manhole frames and covers located within the pavement, providing that such modifications meet the approval of the Town Engineer, AND, BE IT FURTHER

RESOLVED, that all costs associated with the adjustment and modification to sewer district facilities are to be borne by the NYSDOT as an integral part of the highway reconstruction project, AND, BE IT FURTHER

RESOLVED, that the Supervisor be and hereby is directed, on behalf of this Town Board, to sign the Public Utility Work Agreement Form HC-140, submitted by the New York State Department of Transportation, which provides for sanitary sewer district facilities modification and adjustment.

RESULT:	ADOPTED [UNANIMOUS]
MOVER:	Timothy J. Meyers, Councilmember
SECONDER:	Mary Holtz, Supervisor
AYES:	Holtz, Rogowski, Kaminski, Wozniak, Benczkowski, Meyers



14. RESOLUTION 2014-484

Authorize Supervisor to Execute Agreement with Cheektowaga Central School District

Sponsored By: Councilmember Kaminski, Supervisor Holtz

WHEREAS, on occasion, commercial property owners in the Town of Cheektowaga challenge their assessments in court, and

WHEREAS, presently Cheektowaga Central School District and the Town of Cheektowaga utilize different attorneys to represent their interest in court on these legal challenges, and

WHEREAS, representatives of the Town of Cheektowaga met with representatives of Cheektowaga Central School District to discuss sharing attorneys and splitting the costs of such attorneys in order to save taxpayers money, and

WHEREAS, both sides agreed to utilize the Town's attorneys to represent both parties on these assessment challenges, and

WHEREAS, the Town Attorney has prepared an agreement between both parties to accomplish this, NOW, THEREFORE, BE IT

RESOLVED, that the Supervisor be and hereby is authorized and directed to execute the aforementioned agreement between the Town of Cheektowaga and Cheektowaga Central School District on behalf of the Town.

RESULT:	ADOPTED [UNANIMOUS]
MOVER:	Gerald Kaminski, Councilmember
SECONDER:	Mary Holtz, Supervisor
AYES:	Holtz, Rogowski, Kaminski, Wozniak, Benczkowski, Meyers



15. RESOLUTION 2014-485

Authorize Supervisor to Sign Dasherboard Contracts

Sponsored By: Councilmember Wozniak, Councilmember Rogowski

BE IT RESOLVED that subject to approval by the Town Attorney, Supervisor Mary F. Holtz be and hereby is authorized to sign contracts between the Town of Cheektowaga, businesses and/or organizations for dasherboard advertising and ice rentals at the Town Recreation Center during the 2014-2015 season.

FUNDING SOURCE: 0100.7140.4521

REVENUE SOURCE 0100.7140.2128
0100.0882

RESULT:	ADOPTED [UNANIMOUS]
MOVER:	Angela M. Wozniak, Councilmember
SECONDER:	James P. Rogowski, Councilmember
AYES:	Holtz, Rogowski, Kaminski, Wozniak, Benczkowski, Meyers



16. RESOLUTION 2014-486

Authorize Purchase of Copy Machine for Office of Tax Receiver

Sponsored By: Supervisor Holtz, Councilmember Benczkowski

WHEREAS, due to heavy usage and age, the copy machine in the Office of the Tax Receiver is experiencing many breakdowns requiring frequent service calls and maintenance; and

WHEREAS, Toshiba America Business Solutions, Inc. was awarded a bid through the New York State Office of General Services for various Toshiba copy machines (New York State Contract No. PT66219); and

WHEREAS, a local vendor, Eagle Systems, Inc., is an authorized vendor/dealer for Toshiba under said State contract; and

WHEREAS, the Town of Cheektowaga solicited a quotation from Eagle Systems for a Toshiba e-Studio 306 Copier through said State contract; and

WHEREAS, funds for said purchase have been budgeted and are available; NOW, THEREFORE, BE IT

RESOLVED, that this Town Board agrees to purchase the aforesaid copy machine through the following contract awarded by the New York State Office of General Services utilizing a local vendor/authorized dealer, Eagle Systems, Inc., 2421 Harlem Road, Cheektowaga, New York 14225:

Group No. 22424
Contract Award No. 22662
Authorized Dealer: Toshiba America Business Solutions, Inc.,

at a total cost of \$3,509.00, said pricing to include delivery, surge protectors, installation on servers and three workstations, and removal and return of the hard drive on the present copier to the Town of Cheektowaga for destruction; and BE IT FURTHER

RESOLVED, that the cost per copy for maintenance and supplies for said copier will be added to an existing Town contract and will be \$0.008 per black and white copy; and BE IT FURTHER

RESOLVED, that moneys for said purchase shall be appropriated from Office of Tax Receiver account number 100-1410-2201; and BE IT FURTHER

RESOLVED, that the Supervisor be and hereby is authorized and directed to execute all documents and maintenance agreements with Eagle Systems, Inc., to effectuate said purchase, subject to the review and approval of same by the Town Attorney.

RESULT:	ADOPTED [UNANIMOUS]
MOVER:	Mary Holtz, Supervisor
SECONDER:	Diane Benczkowski, Councilmember
AYES:	Holtz, Rogowski, Kaminski, Wozniak, Benczkowski, Meyers



17. RESOLUTION 2014-487

Approve Auction of Town Surplus Vehicles

Sponsored By: Councilmember Kaminski, Supervisor Holtz

WHEREAS, the Town wishes to dispose of a number of surplus motor vehicles that are no longer needed for Town use and BE IT

RESOLVED, that the Town hereby retains Auctions International, Inc. 808 Borden Road, Cheektowaga, NY as per the submitted contract, to conduct a sale of surplus of Town vehicles identified on the attached list at an on-line auction to be held on its website and BE IT FURTHER

RESOLVED, that the Supervisor of the Town of Cheektowaga be and hereby is authorized to execute the aforementioned contract and any and all documents that may be required to effectuated the sale and transfer of all said vehicles and equipment.

Make	Model	VIN #	Fleet #	YEAR	Miles
Autocar	Dump (10 Ton)	4V2SABMD1LU505425	18	1990	120385
Autocar	Dump (10 Ton)	4V2SABMD1LU505427	20	1990	126454
Chevrolet	Pick-up	1GCGK24R6YR195915	102	2000	63315

RESULT: **ADOPTED [UNANIMOUS]**
MOVER: Gerald Kaminski, Councilmember
SECONDER: Mary Holtz, Supervisor
AYES: Holtz, Rogowski, Kaminski, Wozniak, Benczkowski, Meyers



18. RESOLUTION 2014-488

Agreement with NYS Hockey Association

Sponsored By: Councilmember Wozniak, Councilmember Rogowski

BE IT RESOLVED that subject to approval by the Town Attorney, Supervisor Mary F. Holtz be and hereby is authorized to sign an association membership agreement between the Town of Cheektowaga and the New York State Amateur Hockey Association for the 2014-2015 season.

RESULT:	ADOPTED [UNANIMOUS]
MOVER:	Angela M. Wozniak, Councilmember
SECONDER:	James P. Rogowski, Councilmember
AYES:	Holtz, Rogowski, Kaminski, Wozniak, Benczkowski, Meyers



19. RESOLUTION 2014-489

Villa Maria Rental Agreement for Special Olympics Program 2014 - 2015

Sponsored By: Councilmember Wozniak, Councilmember Rogowski

WHEREAS, the Department of Youth and Recreational Services is desirous of entering into a rental agreement with Villa Maria College for use of its swimming pool for its Special Olympics program and

WHEREAS, Villa Maria has agreed to offer its facilities for a discounted rate of \$70 per hour, NOW, THEREFORE BE IT

RESOLVED, that upon approval by the Town Attorney, the Supervisor be and hereby is authorized and directed to execute a rental agreement with Villa Maria College for the Youth & Recreational Services Department Special Olympics Swim Program for the 2014 & 2015 season.

RESULT:	ADOPTED [UNANIMOUS]
MOVER:	Angela M. Wozniak, Councilmember
SECONDER:	James P. Rogowski, Councilmember
AYES:	Holtz, Rogowski, Kaminski, Wozniak, Benczkowski, Meyers



20. RESOLUTION 2014-490

Special Event - Cheektowaga Central Homecoming Parade

Sponsored By: Councilmember Meyers, Councilmember Rogowski

WHEREAS, by resolution dated May 1, 1995, this Town Board adopted a Special Events policy, which requires anyone wishing to hold a special event in the Town to file an application and supporting documentation, fees, etc. to the Town Clerk prior to the special event, and

WHEREAS, the Cheektowaga Central School District has made application to hold its Homecoming Parade on Friday, September 19th, 2014, beginning at 5:45 p.m. (parade route - Union Road, only to cross over to Zoerb and back again from South Creek); and

WHEREAS, this Board has reviewed the aforementioned application, which application has been approved by the Cheektowaga Police Department, and has no objection to same, and

WHEREAS, due to the nature of the event, this Town Board hereby waives the following requirements: Submittal of plan for sanitary facilities;

- 1) Submittal of site plan;
- 2) Requirement that application be made at least 60 days prior to the date of the special event;
- 3) Submittal of Security Plan;
- 4) Submittal of Fire Prevention/Emergency Services Plan.

NOW, THEREFORE, BE IT

RESOLVED, that this Town Board hereby approves the aforementioned application of the Cheektowaga Central School District for the aforementioned Homecoming Parade to be held on Friday, September 19th, 2014, and BE IT FURTHER

RESOLVED, that the Chief of Police be and hereby is directed to provide traffic safety and escort services for such parade and to ensure compliance with Section 1660 (a)(6) of the Vehicle and Traffic Law.

RESULT:	ADOPTED [UNANIMOUS]
MOVER:	Timothy J. Meyers, Councilmember
SECONDER:	James P. Rogowski, Councilmember
AYES:	Holtz, Rogowski, Kaminski, Wozniak, Benczkowski, Meyers



21. RESOLUTION 2014-491

Approve Neighborhood Block Party

Sponsored By: Councilmember Rogowski, Councilmember Meyers

WHEREAS, Chapter 65 of the Code of the Town of Cheektowaga permits the holding of neighborhood block parties or celebrations on town streets during the months of June, July and August, and

WHEREAS, a request was received by this Town Board from residents on a portion of Lucille Drive to hold a block party on September 21, 2014 from 2:00 P.M. to dusk, and

WHEREAS, this Town Board has no objection to the holding of this block party on September 21, 2014, NOW, THEREFORE, BE IT

RESOLVED, that this Town Board hereby waives the requirement of Chapter 65 of the Town Code that block parties be held only during the months of June, July and August; and hereby permits the holding of a block party on a portion of Lucille Drive on September 21, 2014 from 2:00 P.M. to dusk, and BE IT FURTHER

RESOLVED, that said block party shall comply with all other provisions of Chapter 65 of the Town Code.

RESULT:	WITHDRAWN
----------------	------------------



22. RESOLUTION 2014-492

Youth & Recreation Hiring

Sponsored By: Councilmember Wozniak, Councilmember Rogowski

BE IT RESOLVED that the individuals listed below be and hereby are hired, as indicated, in the Department of Youth & Recreational Services, effective immediately:

Recreation Attendant - 7140.1664 - \$13.30 - Regular Part-time

Laila Desjardins

14227

Motion by Councilmember Rogowski; Seconded by Councilmember Meyers to waive the reading of names for the following two (2) resolutions: 2014-492 and 2014-493. Motion Carried.

RESULT: **ADOPTED [UNANIMOUS]**

MOVER: Angela M. Wozniak, Councilmember

SECONDER: James P. Rogowski, Councilmember

AYES: Holtz, Rogowski, Kaminski, Wozniak, Benczkowski, Meyers



23. RESOLUTION 2014-493

Hiring/Termination of Part-Time/Seasonal Employees

Sponsored By: Councilmember Rogowski, Supervisor Holtz

BE IT RESOLVED, that the following individual be and hereby is hired as a **PART-TIME EMPLOYEE** in the department listed, not to exceed nineteen (19) hours on a weekly basis, in compliance with Civil Service Laws and Regulations as well as the provisions of the Town's collective bargaining agreement between the Town of Cheektowaga and the Town of Cheektowaga Employees Association:

SENIOR SERVICES Recreation Attendant \$8.75/hour effective 9/3/14
Donna M. Bohrer, Cheektowaga, New York

BE IT RESOLVED, that the following employee be transferred from part-time to seasonal:

SANITATION DEPARTMENT Laborer \$9.25/hour effective 8/16/14
Michael J. Cristina, Depew, New York

BE IT RESOLVED, that the following seasonal and/or part-time employees be and hereby are terminated as listed:

SEWER MAINTENANCE
Adam J. Cartenuto effective 8/13/14
Eric R. Cartenuto effective 8/16/14

RESULT:	ADOPTED [UNANIMOUS]
MOVER:	James P. Rogowski, Councilmember
SECONDER:	Mary Holtz, Supervisor
AYES:	Holtz, Rogowski, Kaminski, Wozniak, Benczkowski, Meyers



24. RESOLUTION 2014-494

Creation Two (2) Account Clerk Typist Positions

Sponsored By: Councilmember Kaminski, Supervisor Holtz

BE IT RESOLVED, that this Town Board hereby create two (2) Account Clerk Typist positions pursuant to Civil Service Laws and Rules effective September 3, 2014.

RESULT:	ADOPTED [UNANIMOUS]
MOVER:	Gerald Kaminski, Councilmember
SECONDER:	Mary Holtz, Supervisor
AYES:	Holtz, Rogowski, Kaminski, Wozniak, Benczkowski, Meyers



25. RESOLUTION 2014-495

Apptmt of Park Maint Worker I (L/P) Facilities/Justin Borowski

Sponsored By: Councilmember Kaminski, Supervisor Holtz

WHEREAS, a vacancy exists in the title of Park Maintenance Worker I in the Facilities Department (Parks Division); AND

WHEREAS, notice of said vacancy has been posted in accordance with the provisions of the Town's collective bargaining agreement with the Town of Cheektowaga Employees Association; AND

WHEREAS, no full-time bargaining unit bid on said vacancy; AND

WHEREAS, Justin P. Borowski of Depew, New York, currently employed as a temporary Maintenance Worker, applied for said position and meets the necessary qualifications for appointment; NOW, THEREFORE, BE IT

RESOLVED, that Justin P. Borowski of Depew, New York, be and hereby is appointed to the position of Park Maintenance Worker I in the Facilities Department (Parks Division) in accordance with the terms and conditions of the Town's collective bargaining agreement with the Town of Cheektowaga Employees Association effective September 3, 2014.

RESULT:	ADOPTED [UNANIMOUS]
MOVER:	Gerald Kaminski, Councilmember
SECONDER:	Mary Holtz, Supervisor
AYES:	Holtz, Rogowski, Kaminski, Wozniak, Benczkowski, Meyers



26. RESOLUTION 2014-496

Appointment of Account Clerk Typist (Competitive/Permanent) Records Management/Lisa M. Sprada

Sponsored By: Councilmember Kaminski, Supervisor Holtz

WHEREAS, a vacancy exists in the position of Account Clerk Typist in the Records Center; AND

WHEREAS, notice of such vacancy has been posted in accordance with the provisions of the Town's collective bargaining agreement with the Town of Cheektowaga Employees Association; AND

WHEREAS, such job title is in the competitive class of civil service; AND

WHEREAS, Lisa M. Sprada, currently employed as a Senior Sewage Maintenance Worker in the Sewer Maintenance Department, appears on the existing civil service list and meets all the necessary qualifications for appointment; NOW, THEREFORE, BE IT

RESOLVED, that Lisa M. Sprada of Cheektowaga, New York, be and hereby is appointed to the position of Account Clerk Typist in the Records Center in accordance with the terms and conditions of the Town's collective bargaining agreement with the Town of Cheektowaga Employees Association effective September 2, 2014.

RESULT:	ADOPTED [UNANIMOUS]
MOVER:	Gerald Kaminski, Councilmember
SECONDER:	Mary Holtz, Supervisor
AYES:	Holtz, Rogowski, Kaminski, Wozniak, Benczkowski, Meyers



27. RESOLUTION 2014-497

Travel Authorization Office of the Town Assessor/Town Assessor Jeneen M. McSkimming

Sponsored By: Councilmember Benczkowski, Councilmember Kaminski

WHEREAS, the New York State Assessors Association Seminar on Assessment Administration is being held October 5 through October 8, 2014 in Lake Placid, New York; AND

WHEREAS, Town Assessor Jeneen M. McSkimming has requested to attend said seminar; AND

WHEREAS, Ms. McSkimming has submitted a request for travel authorization along with the proper paperwork in a timely manner; AND

WHEREAS, the total cost to the Town shall not exceed \$393; AND

WHEREAS, these expenses have been budgeted by the Department; NOW, THEREFORE, BE IT

RESOLVED, that Town Assessor Jeneen McSkimming be and hereby is authorized to attend the New York State Assessors Association Seminar on Assessment Administration being held October 5 through October 8, 2014 in Lake Placid, New York.

RESULT:	ADOPTED [UNANIMOUS]
MOVER:	Diane Benczkowski, Councilmember
SECONDER:	Gerald Kaminski, Councilmember
AYES:	Holtz, Rogowski, Kaminski, Wozniak, Benczkowski, Meyers



28. RESOLUTION 2014-498

Travel Authorization Building and Plumbing Department/Town Planner Daniel Ulatowski

Sponsored By: Councilmember Benczkowski, Councilmember Kaminski

WHEREAS, The Western Southern Tier Building Officials Educational Conference is being held September 8 through September 10, 2014 in Mayville, New York; AND

WHEREAS, Town Planner Daniel Ulatowski has been recommended to attend said conference;
AND

WHEREAS, Director of Community Development Carla Kosmerl has submitted a request for travel authorization along with the proper paperwork in a timely manner; AND

WHEREAS, the total cost to the Town shall not exceed \$275; AND

WHEREAS, these expenses have been budgeted by the Department; NOW, THEREFORE, BE
IT

RESOLVED, that Town Planner Daniel Ulatowski be and hereby is authorized to attend The Western Southern Tier Building Officials Educational Conference is being held September 8 through September 10, 2014 in Mayville, New York.

RESULT:	ADOPTED [UNANIMOUS]
MOVER:	Diane Benczkowski, Councilmember
SECONDER:	Gerald Kaminski, Councilmember
AYES:	Holtz, Rogowski, Kaminski, Wozniak, Benczkowski, Meyers



29. RESOLUTION 2014-499

Travel Authorization Building and Plumbing Department/Assistant Plumbing Inspector Gregory Magnuszewski

Sponsored By: Councilmember Benczkowski, Councilmember Rogowski

WHEREAS, the Inspecting Solar Watering Heating class is being held September 18, 2014 in Williamsville, New York; AND

WHEREAS, Assistant Plumbing Inspector Gregory Magnuszewski has been recommended to attend said class; AND

WHEREAS, has submitted a request for travel authorization along with the proper paperwork in a timely manner; AND

WHEREAS, the total cost to the Town shall not exceed \$50; AND

WHEREAS, these expenses have been budgeted by the Department; NOW,
THEREFORE, BE IT

RESOLVED, that Assistant Plumbing Inspector Gregory Magnuszewski be and hereby is authorized to attend the Inspecting Solar Watering Heating class being held September 18, 2014 in Williamsville, New York.

RESULT:	ADOPTED [UNANIMOUS]
MOVER:	Diane Benczkowski, Councilmember
SECONDER:	James P. Rogowski, Councilmember
AYES:	Holtz, Rogowski, Kaminski, Wozniak, Benczkowski, Meyers



30. RESOLUTION 2014-500

Travel Authorization Police Department/Police Chief David Zack, Captain Michael Isbrandt and Captain Michael Sliwinski

Sponsored By: Councilmember Benczkowski, Councilmember Kaminski

WHEREAS, the Police Executive Research Forum Summit: Defining Moments for Police Chiefs, is being held September 15 through September 17, 2014, Chicago, Illinois; AND

WHEREAS, Police Chief David Zack has requested to attend said forum along with Captain Michael Isbrandt and Captain Michael Sliwinski; AND

WHEREAS, Police Chief David Zack has submitted a request for travel authorization along with the proper paperwork in a timely manner; AND

WHEREAS, the total cost to the Town shall not exceed \$3,362.43; AND

WHEREAS, these expenses have been budgeted by the Department; NOW, THEREFORE, BE IT

RESOLVED, that Police Chief David Zack, Captain Michael Isbrandt and Captain Michael Sliwinski be and hereby are authorized to attend the Police Executive Research Forum Summit: Defining Moments for Police Chiefs, being held September 15 through September 17, 2014, Chicago, Illinois.

RESULT:	ADOPTED [UNANIMOUS]
MOVER:	Diane Benczkowski, Councilmember
SECONDER:	Gerald Kaminski, Councilmember
AYES:	Holtz, Rogowski, Kaminski, Wozniak, Benczkowski, Meyers

IV. Communications

A. Departmental Communications

1. **Supervisor's Statement of Funds - July 2014**
2. **Drescher & Malecki, LLP: Town of Cheektowaga, New York - State of Changes in Cash Balances and Statements of Cash Receipts and Disbursements of the Receiver of Taxes and Assessments, the Town Clerk and the Town Justices for the Year Ended December 31, 2013 and Independent Auditors' Report**

3. **Drescher & Malecki, LLP: Town of Cheektowaga, New York - New York State Department of Transportation Financial Assistance Schedules for the Year Ended December 31, 2013 and Independent Auditors' Report**
4. **Drescher & Malecki, LLP: Town of Cheektowaga, New York Basic Financial Statements, Required Supplementary Information, Supplemental Information and Federal Financial Assistance Information for the Year Ended December 31, 2013 and Independent Auditors; Reports**
5. **Drescher & Malecki, LLP: Town of Cheektowaga, New York Comprehensive Annual Financial Report for the Fiscal Year Ended December 31, 2013**
6. **Drescher & Malecki, LLP: Town of Cheektowaga, New York Supplement to the Comprehensive Annual Financial Report for the Fiscal Year Ended December 31, 2013**
7. **Drescher & Malecki LLP: Management Letter for the Town of Cheektowaga, New York for the Year Ended December 31, 2013**
8. **Drescher & Malecki LLP: Auditor's Communication Letter for the Town of Cheektowaga, New York for the Year Ended December 31, 2013**

B. General Communications

1. **Summons: MidFirst Bank vs. Dawn M. Stechenfinger, The Town of Cheektowaga & Etal; Premises: 258 Hyland Avenue, Depew, NY**
2. **Notice of Claim: Annette Bitterman vs. Town of Cheektowaga**
3. **Notice of Claim: Thomas J. Mazur vs. Town of Cheektowaga**
4. **Notice of Claim: Progressive a/s/o Scott Janus vs. Town of Cheektowaga**

V. Comments

A. Supervisor's Comments

B. Councilmember's Comments

C. Public Comments

VI. Adjournment

Motion by Councilmember Kaminski; Seconded by Councilmember Rogowski to adjourn the meeting at 7:16 PM

Alice Magierski, Town Clerk



Town of Cheektowaga

Work Session

~ Minutes ~

3301 Broadway
Cheektowaga, NY 14227
<http://www.town.cheektowaga.ny.us>

Alice Magierski
716-686-3400

Tuesday, September 9, 2014

6:00 PM

Council Office

I. Call to Order

6:00 PM Meeting called to order on September 9, 2014 at Council Office, Conference Room, Cheektowaga, NY.

Attendee Name	Organization	Title	Status	Arrived
Mary Holtz	Town of Cheektowaga	Supervisor	Present	
James P. Rogowski	Town of Cheektowaga	Councilmember	Present	
Gerald Kaminski	Town of Cheektowaga	Councilmember	Present	
Angela M. Wozniak	Town of Cheektowaga	Councilmember	Present	
Diane Benczkowski	Town of Cheektowaga	Councilmember	Present	
Timothy J. Meyers	Town of Cheektowaga	Councilmember	Present	

2. Additional Attendees

Brian Krause, Director of Finance and Administration
Jeneen Lomando-McSkimming, Assessor
Karen Marchese, Coordinator of Employee Relations
Kevin Schenk, Town Attorney

3. Motion To: Enter Into Executive Session

COMMENTS - Current Meeting:

To discuss settlement of litigation matter (CM Scrivner vs. Town) and termination and hiring of employees in various departments.

RESULT: ADOPTED [UNANIMOUS]
MOVER: Mary Holtz, Supervisor
SECONDER: James P. Rogowski, Councilmember
AYES: Holtz, Rogowski, Kaminski, Wozniak, Benczkowski, Meyers

4. Motion To: Exit Executive Session

RESULT: ADOPTED [UNANIMOUS]
MOVER: Mary Holtz, Supervisor
SECONDER: Gerald Kaminski, Councilmember
AYES: Holtz, Rogowski, Kaminski, Wozniak, Benczkowski, Meyers

II. Resolutions



1. RESOLUTION 2014-501

Reschedule Public Hearing - 93 Maryvale Drive T-Mobile Northeast , LLC

Sponsored By: Councilmember Benczkowski, Councilmember Rogowski

WHEREAS, T-Mobile Northeast, LLC has made application and requested a special use permit for co-locating a new cellular communications facility on an existing 139 foot tall cell tower at 93 Maryvale Drive, and

WHEREAS, by resolution dated September 2, 2014 (Resolution 2014-478), this Town Board scheduled a public hearing on said special use permit application for Monday, September 15, 2014; but, inadvertently, the legal notice for said public hearing was not published in the CHEEKTOWAGA BEE, NOW, THEREFORE BE IT

RESOLVEDS, that the Public Hearing scheduled for September 15, 2014 for the special use permit application for 93 Maryvale Drive be and hereby is cancelled, and BE IT FURTHER

RESOLVED, that a Public Hearing be held regarding said request under the provisions of the Zoning Law on October 6, 2014 at 6:45 P.M., at the Cheektowaga Town Hall, 3301 Broadway at the corner of Union Road, and BE IT FURTHER

RESOLVED, that the Town Clerk be and hereby is directed to publish the attached Notice of Public Hearing in the CHEEKTOWAGA BEE..



Notice of Public Hearing

NOTICE IS HEREBY GIVEN that a Public Hearing will be held by the Town Board of the Town of Cheektowaga, Erie County, New York at the Town Hall in the said Town of Cheektowaga, 3301 Broadway corner of Union Road on the October 6, 2014 at 6:45 o'clock P.M., of said day for the purpose of considering the application of:

T-Mobile Northeast, LLC

For a special use permit for co-locating a new cellular communications facility on an existing 139 foot tall cell tower at 93 Maryvale Drive,

All parties in interest and citizens will be given an opportunity to be heard in regard to such proposed application.

BY ORDER OF THE TOWN BOARD, Town of Cheektowaga, NY

Alice Magierski, TOWN CLERK



All that tract or parcel of land situate in Town of Cheektowaga, County of Erie, and State

of New York, being part of Lot No. 35, Township 11, Range 7 of the Holland Land Company's Survey, described as follows:

BEGINNING at a point in the southerly line of Maryvale Drive (formerly Pine Ridge Road) distant 160 feet west from the east line of Lot No. 35, said east line of Lot No. 35, being also the west line of Harlem Road as laid out as a 66 foot highway; thence southerly parallel with the east line of Lot No. 35 a distance of 175 feet to a point; thence westerly parallel with Maryvale Drive, a distance of 90 feet to a point; thence northerly parallel with the east line of Lot No. 35 a distance of 175 feet to a point in the southerly line of Maryvale Drive; thence easterly along the southerly line of Maryvale Drive 90 feet to the point or place of beginning.

RESULT:	ADOPTED [UNANIMOUS]
MOVER:	Diane Benczkowski, Councilmember
SECONDER:	James P. Rogowski, Councilmember
AYES:	Holtz, Rogowski, Kaminski, Wozniak, Benczkowski, Meyers



2. RESOLUTION 2014-502

Settlement of Litigation - CM Scrivner, LLC Vs. Town of Cheektowaga

Sponsored By: Councilmember Benczkowski, Supervisor Holtz

WHEREAS, CM Scrivner, LLC commenced Article 7 proceedings against the Town for Tax Years 2011-12, 2012-13, 2013-14 and 2014-15 seeking a reduction in the assessment of properties owned by it located at 1 Scrivner Drive (S.B.L. No. 124.02-2-4.1) and 6 Scrivner Drive (S.B.L. No. 124.02-2-3) in Cheektowaga, New York; and

WHEREAS, the Town's outside Attorney consultant and the Town Assessor have reviewed the petition and, after due consideration of all materials facts, and after negotiations with the petitioner's attorney, believe it is in the best interest of the Town to resolve this matter without further litigation and strongly recommend the proposed compromise; NOW THEREFORE, BE IT

RESOLVED, that the Town Board approves the above compromise and settlement, and the Town's outside Attorney consultant and Town Assessor be and hereby are authorized to execute and procure all papers necessary to effectuate the settlement of said Article 7 proceeding.

RESULT:	ADOPTED [UNANIMOUS]
MOVER:	Diane Benczkowski, Councilmember
SECONDER:	Mary Holtz, Supervisor
AYES:	Holtz, Rogowski, Kaminski, Wozniak, Benczkowski, Meyers



Town of Cheektowaga

Regular Meeting

~ Minutes ~

3301 Broadway
Cheektowaga, NY 14227
<http://www.town.cheektowaga.ny.us>

Alice Magierski
716-686-3400

Monday, September 15, 2014

6:45 PM

Council Chambers

I. Call to Order

6:45 PM Meeting called to order on September 15, 2014 at Council Chambers, 3301 Broadway St, Cheektowaga, NY.

Attendee Name	Organization	Title	Status	Arrived
Mary Holtz	Town of Cheektowaga	Supervisor	Present	
James P. Rogowski	Town of Cheektowaga	Councilmember	Present	
Gerald Kaminski	Town of Cheektowaga	Councilmember	Present	
Angela M. Wozniak	Town of Cheektowaga	Councilmember	Present	
Diane Benczkowski	Town of Cheektowaga	Councilmember	Present	
Timothy J. Meyers	Town of Cheektowaga	Councilmember	Present	

2. Additional Attendees

Patrick Bowen, Town Engineer
Carla A. Kosmerl, Director of Community Development
Brian Krause, Director of Finance and Administration
Karen Marchese, Coordinator of Employee Relations
Kevin Schenk, Town Attorney

II. Public Comment Period

III. Public Hearings

1. Special Use Permit - 4213 Genesee Street S&K Hotels, LLC

COMMENTS - Current Meeting:

This being the time and place advertised for a Public Hearing, the Supervisor directed the Town Clerk to present that such notice has been duly published and posted; upon the order of the Supervisor such proof was duly filed.

No one in attendance, hearing will be rescheduled.

RESULT: CLOSED [UNANIMOUS]
MOVER: Diane Benczkowski, Councilmember
SECONDER: James P. Rogowski, Councilmember
AYES: Holtz, Rogowski, Kaminski, Wozniak, Benczkowski, Meyers

2. Rezoning of 2700 Union Road Rerob, LLC- Express Mart

COMMENTS - Current Meeting:

This being the time and place advertised for a Public Hearing, the Supervisor directed the Town Clerk to present that such notice has been duly published and posted; upon the order of the Supervisor such proof was duly filed.

The Supervisor announced that the Town Board would hear all persons interested in the subject of the hearing. Comments were heard, after which the Supervisor declared the hearing closed, decision was reserved.

RESULT: CLOSED [UNANIMOUS]
MOVER: Diane Benczkowski, Councilmember
SECONDER: James P. Rogowski, Councilmember
AYES: Holtz, Rogowski, Kaminski, Wozniak, Benczkowski, Meyers

**3. Special Use Permit - 2013 Walden Avenue
Panera Bread**

COMMENTS - Current Meeting:

This being the time and place advertised for a Public Hearing, the Supervisor directed the Town Clerk to present that such notice has been duly published and posted; upon the order of the Supervisor such proof was duly filed.

The Supervisor announced that the Town Board would hear all persons interested in the subject of the hearing. Comments were heard, after which the Supervisor declared the hearing closed, decision was reserved.

RESULT: CLOSED [UNANIMOUS]
MOVER: Diane Benczkowski, Councilmember
SECONDER: James P. Rogowski, Councilmember
AYES: Holtz, Rogowski, Kaminski, Wozniak, Benczkowski, Meyers

IV. Resolutions



1. RESOLUTION 2014-503

Warrant

Sponsored By: Supervisor Holtz, Councilmember Kaminski

BE IT RESOLVED, that the following Vouchers & Warrants submitted to the Town of Cheektowaga prior to September 15, 2014 are hereby approved and made part hereof;

GENERAL FUND	\$292,059.29
RISK RETENTION FUND	82,422.46
NYS HOME PROGRAM	0.00
DEBT	0.00
HUD HOUSING REHABILITATION FUND	12,550.00
SPECIAL DISTRICTS FUND	263,378.97
HIGHWAY FUND	90,541.35
CAPITAL FUND	616,727.86
TRUST & AGENCY FUND	6,040.49
HUD CDBG FUND	996.36
PART TOWN FUND	4,134.85
NYS AFFORDABLE HOUSING	0.00
	<hr/>
	\$1,368,851.63

RESULT:	ADOPTED [UNANIMOUS]
MOVER:	Mary Holtz, Supervisor
SECONDER:	Gerald Kaminski, Councilmember
AYES:	Holtz, Rogowski, Kaminski, Wozniak, Benczkowski, Meyers



2. RESOLUTION 2014-504

Approval of Change Order No. 1 - Sewer Maintenance Building Addition and Renovation Project

Sponsored By: Supervisor Holtz, Councilmember Meyers

WHEREAS, the contract for the Sewer Maintenance Building Addition and Renovation Project was awarded by Town Board Resolution dated May 19, 2014 to SM Hayes, LLC, Construction Services, 174 Anderson Place, Buffalo, New York 14222 in the amount of \$506,900.00, AND

WHEREAS, the Project Architect, Aurora Architectural, and the Town Engineer have recommended the approval of Change Order No. 1 which provides for additional site work beyond the original scope of the project as further detailed in the change order document, NOW, THEREFORE, BE IT

RESOLVED, that Change Order No. 1 for the Sewer Maintenance Building Addition and Renovation Project in the amount of \$11,207.25 as an addition to the contract for additional site work, which will be offset by the contract contingency allowance, be and hereby is approved, AND, BE IT FURTHER

RESOLVED, that the Supervisor is hereby authorized and directed to execute said Change Order No. 1 on behalf of this Town Board.

RESULT:	ADOPTED [UNANIMOUS]
MOVER:	Mary Holtz, Supervisor
SECONDER:	Timothy J. Meyers, Councilmember
AYES:	Holtz, Rogowski, Kaminski, Wozniak, Benczkowski, Meyers



3. RESOLUTION 2014-505

Amend Resolution Authorizing Purchase of Copy Machine for Office of Tax Receiver

Sponsored By: Supervisor Holtz, Councilmember Meyers

WHEREAS, by Resolution 2014-486 adopted September 2, 2014, this Town Board authorized the purchase of a copy machine for the Office of the Tax Receiver; and

WHEREAS, said Resolution contained erroneous information and requires correction;
NOW THEREFORE, BE IT

RESOLVED, that the third "WHEREAS" paragraph of Resolution 2014-486 be amended to read as follows:

"WHEREAS, a local vendor, Eagle Systems, Inc., is an authorized *reseller/distributor* for Toshiba under said State contract; and"

and BE IT FURTHER

RESOLVED, that the first "RESOLVED" paragraph of Resolution 2014-486 be amended to read as follows:

"RESOLVED, that this Town Board agrees to purchase the aforesaid copy machine through the following contract awarded by the New York State Office of General Services utilizing a local *reseller/distributor*, Eagle Systems, Inc., 2421 Harlem Road, Cheektowaga, New York 14225:

Group No. 75525
Contract Award No. 22662
Authorized *Contractor*: Toshiba America Business Solutions, Inc.,

at a total cost of \$3,509.00, said pricing to include delivery, surge protectors, installation on servers and three workstations, and removal and return of the hard drive on the present copier to the Town of Cheektowaga for destruction; and BE IT FURTHER."

RESULT:	ADOPTED [UNANIMOUS]
MOVER:	Mary Holtz, Supervisor
SECONDER:	Timothy J. Meyers, Councilmember
AYES:	Holtz, Rogowski, Kaminski, Wozniak, Benczkowski, Meyers



4. RESOLUTION 2014-506

Award of Bid - Firing Range Shelter (Bid #2014-29)

Sponsored By: Councilmember Benczkowski, Councilmember Kaminski

WHEREAS, a Notice to Bidders was published for the receipt of bids for the construction of a Firing Range Shelter located on Scott Place in Cheektowaga, which bids were duly received and opened on July 9, 2014 by the Town Clerk, AND

WHEREAS, said bids were referred to the Town Engineer for analysis, tabulation and report, which tabulation and report is contained in a letter from the Engineering Department dated September 11, 2014, AND

WHEREAS, said letter recommends that the contract for the construction of a new Firing Range Shelter (to include concrete foundations and an engineered metal building system only) be awarded to Building Innovation Group, Inc. for their submission of the lowest bid meeting the requirements of the specifications, NOW, THEREFORE, BE IT

RESOLVED, that the bid for the construction of a new Firing Range Shelter be and hereby is awarded to:

Building Innovation Group, Inc.
107 Lincoln Parkway
East Rochester, New York 14445

for the bid price of \$390,943.00 which includes Base Bid Item #1 - Concrete Foundations and Base Bid Item #2 - Engineered Metal Building System, said being the lowest bid meeting the requirements of the specifications and construction drawings, AND, BE IT FURTHER

RESOLVED, that the Supervisor, on behalf of this Town Board, be and hereby is directed and authorized to execute the contract with Building Innovation Group, Inc. for the aforesaid project, AND, BE IT FURTHER

RESOLVED, that funding for said project shall be chargeable to Account #500-1440-2063-5227 and Account #600-0600-0881.

RESULT:	ADOPTED [UNANIMOUS]
MOVER:	Diane Benczkowski, Councilmember
SECONDER:	Gerald Kaminski, Councilmember
AYES:	Holtz, Rogowski, Kaminski, Wozniak, Benczkowski, Meyers



5. RESOLUTION 2014-507

Acceptance by Town Board of Town of Cheektowaga Supervisory Unit Collective Bargaining Agreement

Sponsored By: Councilmember Kaminski, Supervisor Holtz

WHEREAS, the collective bargaining agreement between the Town of Cheektowaga and the Town of Cheektowaga Supervisory Unit expired on December 31, 2012; AND

WHEREAS, negotiators for the Town and the Supervisory Unit have reached tentative agreement on a successor collective bargaining agreement; AND

WHEREAS, the Town has received notice from the Supervisory Unit that its unit members have ratified the tentative agreement; NOW, THEREFORE, BE IT

RESOLVED, that the Town Board hereby approves the tentative agreement, as presented, for a successor collective bargaining agreement with the Town of Cheektowaga Supervisory Unit for the period January 1, 2013 through December 31, 2015; AND, BE IT FURTHER

RESOLVED, that the Town Supervisor be and hereby is authorized to execute the successor collective bargaining agreement between the Town of Cheektowaga and the Town of Cheektowaga Supervisory Unit for the period January 1, 2013 through December 31, 2015.

RESULT:	ADOPTED [UNANIMOUS]
MOVER:	Gerald Kaminski, Councilmember
SECONDER:	Mary Holtz, Supervisor
AYES:	Holtz, Rogowski, Kaminski, Wozniak, Benczkowski, Meyers



6. RESOLUTION 2014-508

Accept Sidewalk Easement Over 51 Anderson Road

Sponsored By: Councilmember Kaminski, Supervisor Holtz

WHEREAS, KABIR'S, LLC (hereinafter referred to as "KABIR'S") is the owner of property located at 51 Anderson Road in the Town of Cheektowaga; and

WHEREAS, as part of the approval process for the construction of a hotel at this location, KABIR'S agreed to the grant an easement to the Town for the sidewalk which was constructed along Anderson Road; and

WHEREAS, KABIR'S has submitted such easement to the Town for acceptance, and

WHEREAS, the Town Attorney and Town Engineer have reviewed said easement agreement and find same acceptable, NOW, THEREFORE, BE IT

RESOLVED, that this Town Board hereby accepts the aforesaid sidewalk easement, and BE IT FURTHER

RESOLVED, that the Town Attorney be and hereby is directed to arrange for the recording of said easement in the Erie County Clerk's Office.

RESULT:	ADOPTED [UNANIMOUS]
MOVER:	Gerald Kaminski, Councilmember
SECONDER:	Mary Holtz, Supervisor
AYES:	Holtz, Rogowski, Kaminski, Wozniak, Benczkowski, Meyers



7. RESOLUTION 2014-509

Authorize Purchase of Three (3) License Plate Readers

Sponsored By: Councilmember Benczkowski, Councilmember Kaminski

WHEREAS, the Cheektowaga Police Department was awarded a grant through New York State Division of Criminal Justice Services IMPACT Tools (Project ID #IM13-1043-E00), AND

WHEREAS, the grant totals \$50,000.00 and is earmarked for License Plate Readers, of which the Police Department currently owns eight (8) mobile and two (2) stationary License Plate Readers, AND

WHEREAS, the system, which typically captures over 1,500 license plates in an eight (8) hour period, has the ability to read all license plates, advise the police officer if a vehicle is stolen, the registration is suspended and/or the registered owner has a warrant, AND

WHEREAS, ELSAG North America, LLC, 205-H Creek Ridge Road, Greensboro, North Carolina 27406 offers New York State Contract Pricing under Contract #PC62119 for the purchase of License Plate Readers, AND

WHEREAS, the total cost for the three (3) License Plate Readers is \$51,950.00, of which \$50,000.00 will be paid by the IMPACT Tools Grant, AND

WHEREAS, the Cheektowaga Police Department will pay the remaining balance of \$1,950.00 from the Police Asset Forfeiture Line #600-0600-0881, NOW, THEREFORE, BE IT

RESOLVED, that the Cheektowaga Town Board hereby authorizes the Cheektowaga Police Department to purchase the three (3) License Plate Readers.

RESULT:	ADOPTED [UNANIMOUS]
MOVER:	Diane Benczkowski, Councilmember
SECONDER:	Gerald Kaminski, Councilmember
AYES:	Holtz, Rogowski, Kaminski, Wozniak, Benczkowski, Meyers



8. RESOLUTION 2014-510

Authorize Purchase of Copy Machine for Sanitation Department

Sponsored By: Supervisor Holtz, Councilmember Meyers

WHEREAS, due to heavy usage and age, the copy machine in the Sanitation Department is experiencing many breakdowns requiring frequent service calls and maintenance; and

WHEREAS, Toshiba America Business Solutions, Inc. was awarded a bid through the New York State Office of General Services for various Toshiba copy machines (New York State Contract No. PT66219); and

WHEREAS, a local vendor, Eagle Systems, Inc., is an authorized reseller/distributor for Toshiba under said State contract; and

WHEREAS, the Town of Cheektowaga solicited a quotation from Eagle Systems for a Toshiba e-Studio 306 Copier through said State contract; and

WHEREAS, funds for said purchase have been budgeted and are available; NOW, THEREFORE, BE IT

RESOLVED, that this Town Board agrees to purchase the aforesaid copy machine through the following contract awarded by the New York State Office of General Services utilizing a local reseller/distributor, Eagle Systems, Inc., 2421 Harlem Road, Cheektowaga, New York 14225:

Group No. 75525
Contract Award No. 22662
Authorized Contractor: Toshiba America Business Solutions, Inc.,

at a total cost of \$2,847.00, said pricing to include delivery, surge protectors, installation on servers, and removal and return of the hard drive on the present copier to the Town of Cheektowaga for destruction; and BE IT FURTHER

RESOLVED, that the cost per copy for maintenance and supplies for said copier will be added to an existing Town contract and will be \$0.008 per black and white copy; and BE IT FURTHER

RESOLVED, that moneys for said purchase shall be appropriated from Sanitation Department account number 150-8160-4188; and BE IT FURTHER

RESOLVED, that the Supervisor be and hereby is authorized and directed to execute all documents and maintenance agreements with Eagle Systems, Inc., to effectuate said purchase, subject to the review and approval of same by the Town Attorney.

RESULT: **ADOPTED [UNANIMOUS]**
MOVER: Mary Holtz, Supervisor
SECONDER: Timothy J. Meyers, Councilmember
AYES: Holtz, Rogowski, Kaminski, Wozniak, Benczkowski, Meyers



9. RESOLUTION 2014-511

Bonfire - JFK High School

Sponsored By: Supervisor Holtz, Councilmember Benczkowski

WHEREAS, pursuant to the Open Burning Law of the Town of Cheektowaga, the Fire Inspector Gerald Sprada reviews various applications for open fires and open burning and renders his recommendation concerning the fire safety and impact to the general public of such application, AND

WHEREAS, the Town Board, pursuant to the Open Burning Law of the Town of Cheektowaga, is designated the Approval Agency, AND

WHEREAS, since the Town Board is the Approval Agency, it must affirm, modify or reject any recommendations or permits submitted to it by the Town Fire Inspector, Gerald Sprada AND

WHEREAS, an application for a permit was submitted by the JFK High School to conduct a open fire on October 24,2014 on the property located at 305 Cayuga Creek Road, Cheektowaga, New York AND

WHEREAS, the applicant intends to maintain a small bonfire with the assistance of the Doyle 1 & 2 Fire Departments in conjunction with summer youth activities, AND

WHEREAS, the Fire Inspector Gerald Sprada has received this application and finds that all requirements have been met. And that this application is in compliance with conditions and requirement of the Town of Cheektowaga Fire Prevention Code and the Open Burning Law. He requests the Town Board approve issuance of a permit, AND

WHEREAS, this Town Board has reviewed the application submitted by the JFK High School District and the recommendations of the Fire Inspector Gerald Sprada, NOW, THEREFORE, BE IT

RESOLVED, that this Town Board, authorizes the Fire Inspector to issue such permit.

RESULT:	ADOPTED [UNANIMOUS]
MOVER:	Mary Holtz, Supervisor
SECONDER:	Diane Benczkowski, Councilmember
AYES:	Holtz, Rogowski, Kaminski, Wozniak, Benczkowski, Meyers



10. RESOLUTION 2014-512

Special Event- Cleveland Hill High School Homecoming Parade

Sponsored By: Councilmember Meyers, Councilmember Rogowski

WHEREAS, by resolution dated May 1, 1995, this Town Board adopted a Special Events policy, which requires anyone wishing to hold a special event in the Town to file an application and supporting documentation, fees, etc. to the Town Clerk prior to the special event, and

WHEREAS, Cleveland Hill High School has made application to hold its Homecoming Parade on Saturday, October 4, 2014, beginning at 12:00 p.m. (parade route to be provided to the Police Department); and

WHEREAS, this Board has reviewed the aforementioned application, which application has been approved by the Cheektowaga Police Department, and has no objection to same, and

WHEREAS, due to the nature of the event, this Town Board hereby waives the following requirements: Submittal of plan for sanitary facilities;

- 1) Submittal of site plan;
- 2) Requirement that application be made at least 60 days prior to the date of the special event;
- 3) Submittal of Security Plan;
- 4) Submittal of Fire Prevention/Emergency Services Plan.

NOW, THEREFORE, BE IT

RESOLVED, that this Town Board hereby approves the aforementioned application of Cleveland Hill High School for the aforementioned Homecoming Parade to be held on Saturday, October 4, 2014, and BE IT FURTHER

RESOLVED, that the Chief of Police be and hereby is directed to provide traffic safety and escort services for such parade and to ensure compliance with Section 1660 (a)(6) of the Vehicle and Traffic Law.

RESULT:	ADOPTED [UNANIMOUS]
MOVER:	Timothy J. Meyers, Councilmember
SECONDER:	James P. Rogowski, Councilmember
AYES:	Holtz, Rogowski, Kaminski, Wozniak, Benczkowski, Meyers



11. RESOLUTION 2014-513

Unsafe-Unsecured/598 Aero Drive

Sponsored By: Supervisor Holtz, Councilmember Benczkowski

WHEREAS, Town of Cheektowaga Law for the Administration and Enforcement of the Codes of New York State; and the Property Maintenance Code of New York State require that all vacant structures and premises shall be maintained in clean, safe, secure and sanitary conditions so as not to cause a blighting problem or adversely affect the public health or safety and all nuisances abated, AND

WHEREAS, the Town of Cheektowaga has received notification of an unsafe structure and premises located at 598 Aero Drive, Cheektowaga, New York SBL# 81.04-1-10 that is a danger to the safety of others, and records kept by the Assessors Office identify Margaret Gardinier, 598 Aero Drive, Cheektowaga, New York 14225, as the owner AND

WHEREAS, an inspection of such premises was conducted at 598 Aero Drive, by the Housing and Neighborhood Preservation Office, AND

WHEREAS, such inspection found the premises to be deteriorated, vacant, a hazard, and a danger to the safety and well being of others, AND

WHEREAS, the Town of Cheektowaga Housing and Neighborhood Preservation Office properly notified the property owner in accordance with the Town of Cheektowaga Law for the Administration and Enforcement of the Codes of New York State, and the owner failed to take actions to safeguard the premises, AND

WHEREAS, these conditions require the Town of Cheektowaga Housing and Neighborhood Preservation Office to take immediate steps to safeguard the premises to protect the health and safety of others and abate all nuisances, NOW, THEREFORE BE IT

RESOLVED, that pursuant to Section 70-7A.(5) and Section 70-8 of the Town of Cheektowaga Law for the Administration and Enforcement of the Codes of New York State that the vacant structure premises be safeguarded and all nuisances abated; and all costs incurred be assessed against the property hereinbefore described.

RESULT:	ADOPTED [UNANIMOUS]
MOVER:	Mary Holtz, Supervisor
SECONDER:	Diane Benczkowski, Councilmember
AYES:	Holtz, Rogowski, Kaminski, Wozniak, Benczkowski, Meyers



12. RESOLUTION 2014-514

Unsafe-Unsecured Blue Tarp on roof/161 Briarcliff Road

Sponsored By: Supervisor Holtz, Councilmember Benczkowski

WHEREAS, Town of Cheektowaga Law for the Administration and Enforcement of the Codes of New York State; and the Property Maintenance Code of New York State require that all vacant structures and premises shall be maintained in clean, safe, secure and sanitary conditions so as not to cause a blighting problem or adversely affect the public health or safety and all nuisances abated, AND

WHEREAS, the Town of Cheektowaga has received notification of an unsafe structure and premises located at 161 Briarcliff Road, Cheektowaga, New York SBL# 80.18-1-56 That is a danger to the safety of others, and records kept by the Assessors Office identify Karl Roth, 32 Flower Street, Apt Lower, Buffalo, New York 14214 and Victoria Roth, 161 Briarcliff Road, Buffalo, New York 14225 as the owner AND

WHEREAS, an inspection of such premises was conducted at 161 Briarcliff Road, by the Housing and Neighborhood Preservation Office, AND

WHEREAS, such inspection found the premises to be deteriorated, vacant, a hazard, and a danger to the safety and well being of others, AND

WHEREAS, the Town of Cheektowaga Housing and Neighborhood Preservation Office properly notified the property owner in accordance with the Town of Cheektowaga Law for the Administration and Enforcement of the Codes of New York State, and the owner failed to take actions to safeguard the premises, AND

WHEREAS, these conditions require the Town of Cheektowaga Housing and Neighborhood Preservation Office to take immediate steps to safeguard the premises to protect the health and safety of others and abate all nuisances, NOW, THEREFORE BE IT

RESOLVED, that pursuant to Section 70-7A.(5) and Section 70-8 of the Town of Cheektowaga Law for the Administration and Enforcement of the Codes of New York State that the vacant structure premises be safeguarded and all nuisances abated; and all costs incurred be assessed against the property hereinbefore described.

RESULT:	ADOPTED [UNANIMOUS]
MOVER:	Mary Holtz, Supervisor
SECONDER:	Diane Benczkowski, Councilmember
AYES:	Holtz, Rogowski, Kaminski, Wozniak, Benczkowski, Meyers



13. RESOLUTION 2014-515

Unsafe-Unsecured/169 Garland Avenue

Sponsored By: Supervisor Holtz, Councilmember Benczkowski

WHEREAS, Town of Cheektowaga Law for the Administration and Enforcement of the Codes of New York State; and the Property Maintenance Code of New York State require that all vacant structures and premises shall be maintained in clean, safe, secure and sanitary conditions so as not to cause a blighting problem or adversely affect the public health or safety and all nuisances abated, AND

WHEREAS, the Town of Cheektowaga has received notification of an unsafe structure and premises located at 169 Garland Avenue, Cheektowaga, New York SBL# 113.63-2-24 That is a danger to the safety of others, and records kept by the Assessors Office identify Norman Kazmierczak and Wife, 169 Garland Avenue, Cheektowaga, New York 14206, as the owner AND

WHEREAS, an inspection of such premises was conducted at 169 Garland Avenue, by the Housing and Neighborhood Preservation Office, AND

WHEREAS, such inspection found the premises to be deteriorated, vacant, a hazard, and a danger to the safety and well being of others, AND

WHEREAS, the Town of Cheektowaga Housing and Neighborhood Preservation Office properly notified the property owner in accordance with the Town of Cheektowaga Law for the Administration and Enforcement of the Codes of New York State, and the owner failed to take actions to safeguard the premises, AND

WHEREAS, these conditions require the Town of Cheektowaga Housing and Neighborhood Preservation Office to take immediate steps to safeguard the premises to protect the health and safety of others and abate all nuisances, NOW, THEREFORE BE IT

RESOLVED, that pursuant to Section 70-7A.(5) and Section 70-8 of the Town of Cheektowaga Law for the Administration and Enforcement of the Codes of New York State that the vacant structure premises be safeguarded and all nuisances abated; and all costs incurred be assessed against the property hereinbefore described.

RESULT:	ADOPTED [UNANIMOUS]
MOVER:	Mary Holtz, Supervisor
SECONDER:	Diane Benczkowski, Councilmember
AYES:	Holtz, Rogowski, Kaminski, Wozniak, Benczkowski, Meyers



14. RESOLUTION 2014-516

Unsafe-Unsecured/49 Pinehurst Avenue

Sponsored By: Supervisor Holtz, Councilmember Benczkowski

WHEREAS, Town of Cheektowaga Law for the Administration and Enforcement of the Codes of New York State; and the Property Maintenance Code of New York State require that all vacant structures and premises shall be maintained in clean, safe, secure and sanitary conditions so as not to cause a blighting problem or adversely affect the public health or safety and all nuisances abated, AND

WHEREAS, the Town of Cheektowaga has received notification of an unsafe structure and premises located at 49 Pinehurst Avenue, Cheektowaga, New York SBL# 91.19-6-21 that is a danger to the safety of others, and records kept by the Assessors Office identify Jacqueline Acanfora, 13 Nason Pkwy, Buffalo, New York 14218, as the owner AND

WHEREAS, an inspection of such premises was conducted at 49 Pinehurst Avenue, by the Housing and Neighborhood Preservation Office, AND

WHEREAS, such inspection found the premises to be deteriorated, vacant, a hazard, and a danger to the safety and well being of others, AND

WHEREAS, the Town of Cheektowaga Housing and Neighborhood Preservation Office properly notified the property owner in accordance with the Town of Cheektowaga Law for the Administration and Enforcement of the Codes of New York State, and the owner failed to take actions to safeguard the premises, AND

WHEREAS, these conditions require the Town of Cheektowaga Housing and Neighborhood Preservation Office to take immediate steps to safeguard the premises to protect the health and safety of others and abate all nuisances, NOW, THEREFORE BE IT

RESOLVED, that pursuant to Section 70-7A.(5) and Section 70-8 of the Town of Cheektowaga Law for the Administration and Enforcement of the Codes of New York State that the vacant structure premises be safeguarded and all nuisances abated; and all costs incurred be assessed against the property hereinbefore described.

RESULT:	ADOPTED [UNANIMOUS]
MOVER:	Mary Holtz, Supervisor
SECONDER:	Diane Benczkowski, Councilmember
AYES:	Holtz, Rogowski, Kaminski, Wozniak, Benczkowski, Meyers



15. RESOLUTION 2014-517

Unsafe-Unsecured Gutter and Soffit/80 Preston Road

Sponsored By: Supervisor Holtz, Councilmember Benczkowski

WHEREAS, Town of Cheektowaga Law for the Administration and Enforcement of the Codes of New York State; and the Property Maintenance Code of New York State require that all vacant structures and premises shall be maintained in clean, safe, secure and sanitary conditions so as not to cause a blighting problem or adversely affect the public health or safety and all nuisances abated, AND

WHEREAS, the Town of Cheektowaga has received notification of an unsafe structure and premises located at 80 Preston Road, Cheektowaga, New York SBL# 90.76-4-7 that is a danger to the safety of others, and records kept by the Assessors Office identify Audrey Colburn, 76 Park Edge Drive, Cheektowaga, New York 14225, as the owner AND

WHEREAS, an inspection of such premises was conducted at 80 Preston Road, by the Housing and Neighborhood Preservation Office, AND

WHEREAS, such inspection found the premises to be deteriorated, vacant, a hazard, and a danger to the safety and well being of others, AND

WHEREAS, the Town of Cheektowaga Housing and Neighborhood Preservation Office properly notified the property owner in accordance with the Town of Cheektowaga Law for the Administration and Enforcement of the Codes of New York State, and the owner failed to take actions to safeguard the premises, AND

WHEREAS, these conditions require the Town of Cheektowaga Housing and Neighborhood Preservation Office to take immediate steps to safeguard the premises to protect the health and safety of others and abate all nuisances, NOW, THEREFORE BE IT

RESOLVED, that pursuant to Section 70-7A.(5) and Section 70-8 of the Town of Cheektowaga Law for the Administration and Enforcement of the Codes of New York State that the vacant structure premises be safeguarded and all nuisances abated; and all costs incurred be assessed against the property hereinbefore described.

RESULT:	ADOPTED [UNANIMOUS]
MOVER:	Mary Holtz, Supervisor
SECONDER:	Diane Benczkowski, Councilmember
AYES:	Holtz, Rogowski, Kaminski, Wozniak, Benczkowski, Meyers



16. RESOLUTION 2014-518

Unsafe-Unsecured In-ground Pool/99 Princeton Court

Sponsored By: Supervisor Holtz, Councilmember Benczkowski

WHEREAS, Town of Cheektowaga Law for the Administration and Enforcement of the Codes of New York State; and the Property Maintenance Code of New York State require that all vacant structures and premises shall be maintained in clean, safe, secure and sanitary conditions so as not to cause a blighting problem or adversely affect the public health or safety and all nuisances abated, AND

WHEREAS, the Town of Cheektowaga has received notification of an unsafe structure and premises located at 99 Princeton Court, Cheektowaga, New York SBL# 92.05-3-21 that is a danger to the safety of others, and records kept by the Assessors Office identify Wells Fargo Bank, N.A., 1 Home Campus, Des Moines, IA 50328, as the owner AND

WHEREAS, an inspection of such premises was conducted at 99 Princeton Court, by the Housing and Neighborhood Preservation Office, AND

WHEREAS, such inspection found the premises to be deteriorated, vacant, a hazard, and a danger to the safety and well being of others, AND

WHEREAS, the Town of Cheektowaga Housing and Neighborhood Preservation Office properly notified the property owner in accordance with the Town of Cheektowaga Law for the Administration and Enforcement of the Codes of New York State, and the owner failed to take actions to safeguard the premises, AND

WHEREAS, these conditions require the Town of Cheektowaga Housing and Neighborhood Preservation Office to take immediate steps to safeguard the premises to protect the health and safety of others and abate all nuisances, NOW, THEREFORE BE IT

RESOLVED, that pursuant to Section 70-7A.(5) and Section 70-8 of the Town of Cheektowaga Law for the Administration and Enforcement of the Codes of New York State that the vacant structure premises be safeguarded and all nuisances abated; and all costs incurred be assessed against the property hereinbefore described.

RESULT:	ADOPTED [UNANIMOUS]
MOVER:	Mary Holtz, Supervisor
SECONDER:	Diane Benczkowski, Councilmember
AYES:	Holtz, Rogowski, Kaminski, Wozniak, Benczkowski, Meyers



17. RESOLUTION 2014-519

Unsafe-Unsecured/228 Wagner Street

Sponsored By: Supervisor Holtz, Councilmember Benczkowski

WHEREAS, Town of Cheektowaga Law for the Administration and Enforcement of the Codes of New York State; and the Property Maintenance Code of New York State require that all vacant structures and premises shall be maintained in clean, safe, secure and sanitary conditions so as not to cause a blighting problem or adversely affect the public health or safety and all nuisances abated, AND

WHEREAS, the Town of Cheektowaga has received notification of an unsafe structure and premises located at 228 Wagner Street, Cheektowaga, New York SBL# 112.68-4-5 that is a danger to the safety of others, and records kept by the Assessors Office identify Donald Sliwinski, 228 Wagner Street, Cheektowaga, New York 14206, as the owner AND

WHEREAS, an inspection of such premises was conducted at 228 Wagner Street, by the Housing and Neighborhood Preservation Office, AND

WHEREAS, such inspection found the premises to be deteriorated, vacant, a hazard, and a danger to the safety and well being of others, AND

WHEREAS, the Town of Cheektowaga Housing and Neighborhood Preservation Office properly notified the property owner in accordance with the Town of Cheektowaga Law for the Administration and Enforcement of the Codes of New York State, and the owner failed to take actions to safeguard the premises, AND

WHEREAS, these conditions require the Town of Cheektowaga Housing and Neighborhood Preservation Office to take immediate steps to safeguard the premises to protect the health and safety of others and abate all nuisances, NOW, THEREFORE BE IT

RESOLVED, that pursuant to Section 70-7A.(5) and Section 70-8 of the Town of Cheektowaga Law for the Administration and Enforcement of the Codes of New York State that the vacant structure premises be safeguarded and all nuisances abated; and all costs incurred be assessed against the property hereinbefore described.

RESULT:	ADOPTED [UNANIMOUS]
MOVER:	Mary Holtz, Supervisor
SECONDER:	Diane Benczkowski, Councilmember
AYES:	Holtz, Rogowski, Kaminski, Wozniak, Benczkowski, Meyers



18. RESOLUTION 2014-520

Youth & Recreation Terminations

Sponsored By: Councilmember Wozniak, Councilmember Rogowski

BE IT RESOLVED that the individuals listed below be and herby are terminated in the Department of Youth & Recreational Services effective as indicated:

Anthony Albright	8/17/14	14225
Gabriel Amato	8/15/14	14225
Josh Atzrott	8/19/14	14215
Kelley Astyk	8/14/14	14227
Ashley Bajer	8/24/14	14225
Dylan Bajer	8/19/14	14225
Tyler Bajer	8/19/14	14225
Chelsey Balistrieri	8/20/14	14225
Adam Barrett	8/23/14	14225
Brad Bauman	8/15/14	14227
Ross Bauman	8/15/14	14227
Lucas Baumgart	8/29/14	14225
Bryce Bielani	8/15/14	14215
Shannon Borowiak	8/21/14	14227
Justin Brackna	8/19/14	14225
Amanda Brodfuehrer	8/24/14	14227
Logan Brunner	8/26/14	14043
Jennifer Buczek	8/22/14	14227
Jonathan Burlett	8/23/14	14211
Samantha Burton	8/14/14	14225
Lynne Butts	11/03/13	14225
Jessica Calandra	8/22/14	14215
Nolan Calos	8/15/14	14227
Paige Casillo	8/15/14	14227
Jessie Cecere	8/15/14	14225
Amanda Cendrowski	8/30/13	14212
Jeffrey Creighton	8/15/14	14225
Andrew Deeds	8/23/14	14211
William Dickinson	8/19/14	14225
Caitlin Deveny	8/20/14	14225
Tyler Diebold	8/26/14	14225
Tyler Ditta	8/15/14	14211
Julianne Doetterl	8/22/14	14227
Kayla Doetterl	8/24/14	14227
Kristina Doetterl	8/22/14	14227
Frederick Drzewiecki III	8/20/14	14225
Margaret Drzewiecki	8/19/14	14225
Matthew Eckle	8/22/14	14225
Meghan Eckle	8/21/14	14225
Daniel Eye	8/29/14	14225
Jessie Farris	8/06/14	14212
Melissa Farruggio	8/20/14	14227

Emily Ferber	8/21/14	14225
Amanda Fischer	8/04/14	14227
Lindsey Fritsch	8/13/14	14215
Joshua Fruchtel	8/15/14	14225
Rocco Fumerelle	8/20/14	14227
Joshua Galante	9/05/14	14206
Shelby Gennocro	8/15/14	14225
Maryann Glab	8/15/14	14227
Lennon Cavanaugh-Gordon	8/19/14	14215
Haley Graczyk	8/15/14	14225
Katie Gramlich	8/15/14	14225
Dakota Grantham	8/23/14	14225
Kayla Green	8/15/14	14225
James Hanners	8/22/14	14225
Matthew Hencinski	8/13/14	14227
Kira Herkey	8/14/14	14225
Zachary Hermanski	8/17/14	14225
Catherine Huber	8/15/14	14225
Ronald Jerozal	8/29/14	14227
Cody Jeziorski	8/23/14	14227
Adrianna Johnson	8/15/14	14225
Brian Johnson	8/25/14	14227
Samantha Johnston	8/23/14	14227
Zachary Jones	8/16/14	14225
Kyle Kaminski	6/17/14	14227
Sarah Kapanek	8/06/14	14206
Connor Karek	8/17/14	14225
Ben Kean	8/18/14	14075
Michael Keller	8/14/14	14225
Christopher Kelley	8/22/14	14215
Stephen Kelly	8/19/14	14211
Jordan Kilijanski	7/30/14	14227
Amanda Kiripolsky	8/15/14	14215
Christopher Kiripolsky	8/19/14	14215
Raena Koepfel	8/13/14	14225
Kaitlyn Kraebel	8/20/14	14227
Amanda Kraus	8/16/14	14225
Alexis Krueger	8/19/14	14215
Keith Kwiatkowski	8/29/14	14227
Trevor Krzemien	8/19/14	14227
Natalie Lane	8/15/14	14215
Rebecca Langa	8/21/14	14043
Maurice Lee III	8/15/14	14225
Alex Lenhard	8/22/14	14227
Robert Love	8/19/14	14225
Joshua MacTarnaghan	8/15/14	14043
Felicia Magnuszewski	8/14/14	14043
Lori Majewski	8/23/14	14227
Danielle Malicki	8/15/14	14227
Gaetano Mancuso	8/25/14	14227
Andrew Matulich	8/15/14	14225
Noah McGhee	7/25/14	14225
Charles McGregor	8/13/14	14227
Paige Melin	8/15/14	14206

Andrew Meyerhofer	8/15/14	14225
Morgan Miecznikowski	8/20/14	14225
Cassidy Moore	8/19/14	14225
Haley Muehlbauer	8/15/14	14225
Allison Musial	8/18/14	14225
Eric Nash	8/28/14	14206
Jamie Nash	8/28/14	14206
Paul A. Nazzarett III	8/19/14	14227
Matthew Nichy	8/29/14	14043
Steven Nichy	8/15/14	14043
Zoe Obstarczyk	8/12/14	14211
Andrea O'Shea	8/15/14	14043
Anthony Overfield	8/10/14	14227
Nathan Pazderski	8/18/14	14227
Katelin Petranchuk	8/15/14	14227
Brianna Poules	8/13/14	14227
Samantha Poules	8/20/14	14227
Stephen Pfalzer	8/29/14	14043
Marshall Prestia	8/23/14	14211
Robert Pulkownik	8/21/14	14227
Nicole Putland	8/19/14	14225
Noah Radlich	8/14/14	14225
Alyssa Reesor	8/15/14	14211
Stephanie Reesor	8/15/14	14211
Kevin Lopez-Rodriguez	8/19/14	14225
Zachery Russillo	8/15/14	14227
Robert Rustowicz	8/14/14	14225
Andrew Samer	8/08/14	14227
Kaylee Sandel	8/19/14	14227
Adam Skowron	8/25/14	14227
Erin Ruthenberg	8/15/14	14225
Alexa Scharf	8/23/14	14225
Ashley Schrader	8/22/14	14225
Kristen Schugardt	8/22/14	14043
Jayson Schultz	8/24/14	14211
Brandon Seifert	8/19/14	14225
Maria Serio	8/19/14	14225
Jordan Soldaczewski	8/15/14	14225
Ashley Sokol	8/22/14	14227
Michael Sokol	8/18/14	14227
Ashley Spencer	8/15/14	14211
Samantha Sprada	8/22/14	14206
Robyn Stanley	8/21/14	14225
Aaron Stolinski	8/10/14	14227
Jocelyn Strohm	8/13/14	14225
Josh Strzelec	8/15/14	14211
Christopher Suchan	8/26/14	14227
Tyler Suchan	8/26/14	14227
Benjamin Sullivan	8/19/14	14225
David Taylor	8/15/14	14215
Kyle Tobin	8/15/14	14215
Cerene Usinski	8/22/14	14225
Kaliana Veros	8/15/14	14206
James Urshel	8/26/14	14043

Zachary Uzar	8/26/14	14227
Chelsea Wartinger	8/14/14	14043
Samantha Wayne	8/15/14	14227
Joesph Weber	8/14/14	14225
Tyler Welsh	8/24/14	14225
Courtney Wesolowski	1/24/14	14206
Kelsey Wiegert	8/15/14	14211
Daniel Wierzba	8/19/14	14212
Colleen Wilkie	8/19/14	14043
Brandon Williams	8/22/14	14043
Alexandria Wnuk	8/15/14	14043
Hayley Wnuk	8/19/14	14043
Madeline Wnuk	8/15/14	14043
Alexe Wodowski	8/20/14	14227
Jessica Woods	8/15/14	14225
Michael Zarbo	8/19/14	14227
John Zastempowski IV	8/19/14	14227

Motion by Councilmember Rogowski; Seconded by Councilmember Benczkowski to waive the reading of names for this resolution. Motion carried.

RESULT: **ADOPTED [UNANIMOUS]**
MOVER: Angela M. Wozniak, Councilmember
SECONDER: James P. Rogowski, Councilmember
AYES: Holtz, Rogowski, Kaminski, Wozniak, Benczkowski, Meyers



19. RESOLUTION 2014-521

Youth & Recreation Transfers

Sponsored By: Councilmember Wozniak, Councilmember Rogowski

BE IT RESOLVED that the individuals listed below be and hereby are transferred, as indicated, in the Department of Youth & Recreational Services, effective immediately:

Laborer "Bathhouse Attendant" - 7180.1901 to Recreation Aide - 7140.1611- Part-time - \$8.25
Paul Ciaflone

Recreation Attendant - 7140.1614 - Seasonal to Recreation Attendant 7140.1614 - Regular Part-time - \$8.75
Harley Wiertel

Lifeguard - "Level II" - 7180.1903 - \$9.18 - Regular Part-time
Ariana D'Agostino
Ryan Osswald

Lifeguard - "Level III" - 7180.1903 - \$9.36 - Regular Part-time
Timothy Petranchuk Jr.

Recreation Attendant - Seasonal to Recreation Attendant - \$8.00 - 7310.1803 - Regular Part-time
Michael Jerome McGregor

RESULT:	ADOPTED [UNANIMOUS]
MOVER:	Angela M. Wozniak, Councilmember
SECONDER:	James P. Rogowski, Councilmember
AYES:	Holtz, Rogowski, Kaminski, Wozniak, Benczkowski, Meyers



20. RESOLUTION 2014-522

Termination/Amendment/Adjustment of Hourly Wages of Part-Time/Seasonal Employees

Sponsored By: Councilmember Kaminski, Supervisor Holtz

BE IT RESOLVED, that the following seasonal and/or part-time employees be and hereby are terminated:

SEWER MAINTENANCE
Nicholas Kotarski effective 8/30/14

ASSESSOR'S OFFICE
Paula R. Murphy effective 8/20/14

SANITATION DEPARTMENT
Jordan C. Maund effective 9/6/14

BE IT RESOLVED, that the following employees' status be amended:

SANITATION DEPARTMENT Seasonal to Part-Time Laborer \$9.25/hour effective 8/16/14
Michael J. Cristina, Depew, New York

BE IT RESOLVED, that the following employees' rate of pay be adjusted as follows:

FACILITIES DEPARTMENT (Parks Division) Laborer (Part Time) \$9.25/hour effective 9/16/14
Joseph A. Galletta
Patricia Kantor
Thomas L. Krawczyk
Daniel E. Olejniczak
James J. Brundo
Robert D. Fetter
John E. Gluszek
Justin H. Griner
Nicholas R. Herkey
Alexander W. Kluck
Craig R. Maconaghy, Jr.
Christopher D. O'Neill
Robert J. Bommer, III
Matthew J. Pazderski

FACILITIES DEPARTMENT (Parks Division) Clerk (Part Time) \$12.50/hour effective 9/16/14
Joan C. Meyers

FACILITIES DEPARTMENT (Parks Division) Laborer (Seasonal) \$9.25/hour effective 9/16/14
Eric J. Tomczak
Brandon P. Barczak
Tyler M. Elis
Brandon M. Kindzierski

Matthew A. Rakowski
Michael W. Kowal

FACILITIES DEPARTMENT (Building and Grounds Division) Laborer (Part Time) \$9.25/hour
effective 9/16/14

Cynthia M. Schaefer
Ronald J. Lewandowski
William W. Lauber
John G. Matecki
Gerald P. Scheib

FACILITIES DEPARTMENT (Buildings and Grounds Division) Laborer (Seasonal) \$9.00/hour
effective 9/16/14

Ryan E. Pocobello

RESULT:	ADOPTED [5 TO 0]
MOVER:	Gerald Kaminski, Councilmember
SECONDER:	Mary Holtz, Supervisor
AYES:	Holtz, Rogowski, Kaminski, Wozniak, Benczkowski
ABSTAIN:	Timothy J. Meyers



21. RESOLUTION 2014-523

Hire Actuary for GASB 45 Calculation

Sponsored By: Supervisor Holtz, Councilmember Kaminski

WHEREAS, the Government Accounting Standards Board (GASB) has issued Statement #45 requiring governments to account for other post employment benefits, and

WHEREAS, this statement requires an actuarial valuation be performed of the Town's post retirement health care benefits at minimum every two years which 2014 is the second year from the last valuation, and

WHEREAS, the Town has received a professional services proposal from Hawley Consulting Group to perform the necessary actuarial services to be in compliance with this GASB statement #45 and,

RESOLVED, that the Town engage Hawley Consulting Group to perform the necessary actuarial services relating to the Town's post retirement health care benefits per their April 2014 proposal in the amount of \$9,000.

RESULT:	ADOPTED [UNANIMOUS]
MOVER:	Mary Holtz, Supervisor
SECONDER:	Gerald Kaminski, Councilmember
AYES:	Holtz, Rogowski, Kaminski, Wozniak, Benczkowski, Meyers



22. RESOLUTION 2014-524

Authorization of Student Interns (Police Department)

Sponsored By: Councilmember Benczkowski, Councilmember Kaminski

WHEREAS, Nicole A. Gulisano, a student at Medaille College, Teresa L. Wegner, a student at Hilbert College, Janel L. Poczciwinski, a student at Hilbert College, and Derek R. Braun, a student at Buffalo State College, have requested to participate in the student internship program at the Police Department; AND

WHEREAS, these individuals have been interviewed by the Police Department and the Police Department is willing to afford them the opportunity to intern in the Police Department; NOW, THEREFORE, BE IT

RESOLVED, that Nicole A. Gulisano of Cheektowaga, New York, Teresa L. Wegner of West Seneca, New York, Janel L. Poczciwinski of Cheektowaga, New York and Derek R. Braun of Cheektowaga, New York, be and hereby are authorized to participate as unpaid interns in the Police Department, subject to their execution of a Waiver of Liability and Agreement of Confidentiality; AND, BE IT FURTHER

RESOLVED, that Nicole A. Gulisano, Teresa L. Wegner, Janel L. Poczciwinski, and Derek R. Braun's internships be and hereby are effective September 2, 2014 through December 31, 2014; AND, BE IT FURTHER

RESOLVED, that the Supervisor be and hereby is authorized and directed to execute the Agreement of Confidentiality, and all other documents necessary to effectuate these student internships in the Police Departments.

RESULT:	ADOPTED [UNANIMOUS]
MOVER:	Diane Benczkowski, Councilmember
SECONDER:	Gerald Kaminski, Councilmember
AYES:	Holtz, Rogowski, Kaminski, Wozniak, Benczkowski, Meyers



23. RESOLUTION 2014-525

Appointment of General Crew Chief /Sanitation Department (Non-Competitive/Permanent) David N. Longo

Sponsored By: Councilmember Kaminski, Supervisor Holtz

WHEREAS, a vacancy exists in the title of General Crew Chief in the Sanitation Department; AND

WHEREAS, notice of such vacancy has been posted in accordance with the provisions of the Town's collective bargaining agreement with the Town of Cheektowaga Supervisory Unit; AND

WHEREAS, David N. Longo, currently employed as a Working Crew Chief in the Sanitation Department, bid on said vacancy and meets the necessary qualifications for appointment; NOW, THEREFORE BE IT

RESOLVED, that David N. Longo, of Cheektowaga, New York, be and hereby is appointed to the position of General Crew Chief in the Sanitation Department in accordance with the terms and conditions of the Town's collective bargaining agreement with the Town of Cheektowaga Supervisory Unit effective September 17, 2014.

RESULT:	ADOPTED [UNANIMOUS]
MOVER:	Gerald Kaminski, Councilmember
SECONDER:	Mary Holtz, Supervisor
AYES:	Holtz, Rogowski, Kaminski, Wozniak, Benczkowski, Meyers



24. RESOLUTION 2014-526

Travel Authorization Senior Services/Recreation Leader Camille Russell and Recreation Supervisor Dawn Bellere

Sponsored By: Councilmember Kaminski, Supervisor Holtz

WHEREAS, the Social Media Marketing Conference is being held October 27, 2014 in Buffalo, New York; AND

WHEREAS, Recreation Leader Camille Russell and Recreation Supervisor Dawn Bellere have been recommended to attend said conference; AND

WHEREAS, Director of Senior Services Kerry Switalski has submitted a request for travel authorization along with the proper paperwork in a timely manner; AND

WHEREAS, the total cost to the Town shall not exceed \$438; AND

WHEREAS, these expenses have been budgeted by the Department; NOW,
THEREFORE, BE IT

RESOLVED, that Recreation Leader Camille Russell and Recreation Supervisor Dawn Bellere be and hereby are authorized to attend the Social Media Marketing Conference being held October 27, 2014 in Buffalo, New York.

RESULT:	ADOPTED [UNANIMOUS]
MOVER:	Gerald Kaminski, Councilmember
SECONDER:	Mary Holtz, Supervisor
AYES:	Holtz, Rogowski, Kaminski, Wozniak, Benczkowski, Meyers



25. RESOLUTION 2014-527

Travel Authorization Senior Services/Director of Senior Services Kerry Switalski

Sponsored By: Councilmember Kaminski, Supervisor Holtz

WHEREAS, the Summit On Aging and Independence and Culture is being held September 24 through September 25, 2014 in Niagara Falls, New York; AND

WHEREAS, Director of Senior Services Kerry Switalski has submitted a request for travel authorization along with the proper paperwork in a timely manner; AND

WHEREAS, the total cost to the Town shall not exceed \$346; AND

WHEREAS, these expenses have been budgeted by the Department; NOW, THEREFORE, BE IT

RESOLVED, that Director of Senior Services Kerry Switalski be and hereby is authorized to attend the Summit On Aging and Independence and Culture being held September 24 through September 25, 2014 in Niagara Falls, New York.

RESULT:	ADOPTED [UNANIMOUS]
MOVER:	Gerald Kaminski, Councilmember
SECONDER:	Mary Holtz, Supervisor
AYES:	Holtz, Rogowski, Kaminski, Wozniak, Benczkowski, Meyers

V. Communications

A. Departmental Communications

1. Minutes: Cheektowaga Planning Board - August 14, 2014

B. General Communications

1. Drescher & Malecki: Town of Cheektowaga, New York Statement of Changes in Cash Balances and Statements of Cash Receipts and Disbursements of the Receiver of Taxes and Assessments, the Town Clerk and the Town Justices for the Year Ended December 31, 2013 and Independent Auditors' Report
2. Summons: Citimortgage, Inc. vs. Cynthia M. Malkiewicz, The Town of Cheektowaga & Etal Premises Address: 32 Randolph Ave.

- 3. Notice of Claim: Shawn Ciesiulka vs. Town of Cheektowaga
- 4. Notice of Claim: Eugene Czajkowski vs. Town of Cheektowaga

VI. Comments

A. Supervisor's Comments

B. Councilmember's Comments

C. Public Comments

VII. Adjournment

Motion by Supervisor Holtz; Seconded by Councilmember Rogowski to adjourn the meeting at 7:37 PM

Alice Magierski, Town Clerk



Town of Cheektowaga

Regular Meeting

~ Minutes ~

3301 Broadway
Cheektowaga, NY 14227
<http://www.town.cheektowaga.ny.us>

Alice Magierski
716-686-3400

Monday, October 6, 2014

6:45 PM

Council Chambers

I. Call to Order

6:45 PM Meeting called to order on October 6, 2014 at Council Chambers, 3301 Broadway St, Cheektowaga, NY.

Attendee Name	Organization	Title	Status	Arrived
Mary Holtz	Town of Cheektowaga	Supervisor	Absent	
James P. Rogowski	Town of Cheektowaga	Councilmember	Present	
Gerald Kaminski	Town of Cheektowaga	Councilmember	Present	
Angela M. Wozniak	Town of Cheektowaga	Councilmember	Present	
Diane Benczkowski	Town of Cheektowaga	Councilmember	Present	
Timothy J. Meyers	Town of Cheektowaga	Councilmember	Present	

2. Additional Attendees

- Patrick Bowen, Town Engineer
- Robert Brandon, Zoning Board Chairman
- Patrick Burke, Erie County Legislator
- Carla A. Kosmerl, Director of Community Development
- Karen Marchese, Coordinator of Employee Relations
- Kevin Schenk, Town Attorney
- Mark Wegner, Highway Superintendent

II. Public Comment Period

III. Public Hearing

1. Special Use Permit - 93 Maryvale Drive T-Mobile Northeast , LLC

COMMENTS - Current Meeting:

This being the time and place advertised for a Public Hearing, the Supervisor directed the Town Clerk to present that such notice has been duly published and posted; upon the order of the Supervisor such proof was duly filed.

The Supervisor announced that the Town Board would hear all persons interested in the subject of the hearing. Comments were heard, after which the Supervisor declared the hearing closed, decision was reserved.

RESULT:	CLOSED [UNANIMOUS]
MOVER:	Diane Benczkowski, Councilmember
SECONDER:	James P. Rogowski, Councilmember
AYES:	Rogowski, Kaminski, Wozniak, Benczkowski, Meyers
ABSENT:	Mary Holtz

IV. Resolutions



1. RESOLUTION 2014-528

Transfer of Funds

Sponsored By: Councilmember Kaminski, Councilmember Rogowski

BE IT RESOLVED, that the following transfer is hereby approved and made part hereof;

GENERAL

FROM:	100.1355.4411	Petition Filing Refunds(SCAR)	\$900.00
	100.1356.4511	Transcript Services(BOAR)	150.00
TO:	100.1355.4082	Seminars & Memberships	\$900.00
	100.1355.4001	Office Supplies	150.00

RESULT:	ADOPTED [UNANIMOUS]
MOVER:	Gerald Kaminski, Councilmember
SECONDER:	James P. Rogowski, Councilmember
AYES:	Rogowski, Kaminski, Wozniak, Benczkowski, Meyers
ABSENT:	Mary Holtz



2. RESOLUTION 2014-529

Warrant

Sponsored By: Councilmember Kaminski, Councilmember Rogowski

BE IT RESOLVED, that the following Vouchers & Warrants submitted to the Town of Cheektowaga prior to October 6, 2014 are hereby approved and made part hereof;

GENERAL FUND	\$3,228,221.11
RISK RETENTION FUND	703,628.87
NYS HOME PROGRAM	0.00
DEBT	0.00
HUD HOUSING REHABILITATION FUND	69,377.00
SPECIAL DISTRICTS FUND	938,231.11
HIGHWAY FUND	519,551.93
CAPITAL FUND	808,823.10
TRUST & AGENCY FUND	14,306.22
HUD CDBG FUND	19,632.40
PART TOWN FUND	221,992.51
NYS AFFORDABLE HOUSING	0.00
	\$6,523,764.25

RESULT:	ADOPTED [UNANIMOUS]
MOVER:	Gerald Kaminski, Councilmember
SECONDER:	James P. Rogowski, Councilmember
AYES:	Rogowski, Kaminski, Wozniak, Benczkowski, Meyers
ABSENT:	Mary Holtz



3. RESOLUTION 2014-530

Negative SEQR Declaration - 2013 Walden Avenue Panera Bread

Sponsored By: Councilmember Meyers, Councilmember Kaminski

WHEREAS, pursuant to the Environmental Impact Review Ordinance of the Town of Cheektowaga, the Environmental Advisory Committee ("EAC") reviews various applications for site plans, rezonings, special permits, etc. And renders its recommendation concerning the environmental significance of such application, AND

WHEREAS, an application was submitted by Benderson Development Co., LLC for a special use permit to permit for an accessory drive though window to an existing restaurant at 2013 Walden Avenue, said application also includes consideration of a site plan for a 2,301 s.f. building addition, AND

WHEREAS, the Town Board, pursuant to the Environmental Impact Review Ordinance of the Town of Cheektowaga, is designated the Lead Agency, AND

WHEREAS, since the Town Board is the Lead Agency, it must affirm, modify or reject any recommendations submitted to it by the Advisory Committee, AND

WHEREAS, the Town of Cheektowaga Planning Board recommended approval of the site plan at their meeting of August 14, 2014, AND

WHEREAS, the Town of Cheektowaga Traffic Safety Commission has reviewed the subject project and is recommending its approval, AND

WHEREAS, the Environmental Advisory Committee at its meetings held on September 17, 2014 recommended a determination of non-significance, AND

WHEREAS, this Town Board has reviewed the application submitted and the recommendations made by the Environmental Advisory Committee, the Planning Board and the Traffic Safety Commission, NOW, THEREFORE, BE IT

RESOLVED, that this Town Board determines that the project will not have a significant effect on the environment and therefore issues a Negative Declaration for purposes of the State Environmental Quality Review Act (SEQRA).

RESULT:	ADOPTED [UNANIMOUS]
MOVER:	Timothy J. Meyers, Councilmember
SECONDER:	Gerald Kaminski, Councilmember
AYES:	Rogowski, Kaminski, Wozniak, Benczkowski, Meyers
ABSENT:	Mary Holtz



4. RESOLUTION 2014-531

Accept Site Plan- 2013 Walden Avenue Panera Bread

Sponsored By: Councilmember Benczkowski, Councilmember Rogowski

WHEREAS, pursuant to the Zoning Law of the Town of Cheektowaga, the Planning Board reviews various development review applications for site plans, rezonings, special permits and realty subdivisions and renders its recommendation concerning the compatibility of such application with the zoning regulations, the Town Master Plan and neighborhood character, AND

WHEREAS, the Town Board, pursuant to section 260-47.1C of the Zoning Law of the Town of Cheektowaga is vested with the authority to approve site plans and modify or reject any recommendation submitted to it by its advisory committees, AND

WHEREAS, Benderson Development Co., LLC. Submitted a development review application for a 2,301 s.f. building addition to an existing restaurant at 2013 Walden Avenue to accommodate two new restaurant tenants, one of which will also have an accessory drive through window, AND

WHEREAS, the Town of Cheektowaga Planning Board, reviewed and commented on the Application at their meeting of August 14, 2014 and have recommended approval thereof, NOW THEREFORE BE IT,

RESOLVED, that pursuant to Section 260-47-1 of the Code of the Town of Cheektowaga and Section 274-a of New York State Town Law that this Town Board approves the proposed site plan.

1. Subject to a modification of the ingress traffic routing at the internal roadway intersection and the proposed drive through exit; to minimize internal traffic conflicts for vehicles exiting the drive thru lane and vehicles entering the adjacent two way parking access aisle.

RESULT:	WITHDRAWN
----------------	------------------



5. RESOLUTION 2014-532

Accept Site Plan- 4822 Genesee Street M.P. Carol Hardwood

Sponsored By: Councilmember Benczkowski, Councilmember Rogowski

WHEREAS, pursuant to the Zoning Law of the Town of Cheektowaga, the Planning Board reviews various development review applications for site plans, rezonings, special permits and realty subdivisions and renders its recommendation concerning the compatibility of such application with the zoning regulations, the Town Master Plan and neighborhood character, AND

WHEREAS, the Town Board, pursuant to section 260-47.1C of the Zoning Law of the Town of Cheektowaga is vested with the authority to approve site plans and modify or reject any recommendation submitted to it by its advisory committees, AND

WHEREAS, M.P. Carol Hardwood submitted a development review application for the construction of a 1,388 s.f. building addition to an existing retail; flooring distribution facility at 4822 Genesee Street, AND

WHEREAS, the Town of Cheektowaga Planning Board, reviewed and commented on the Application at their meeting of September 11, 2014 and have recommended approval thereof, NOW THEREFORE BE IT,

RESOLVED, that pursuant to Section 260-47-1 of the Code of the Town of Cheektowaga and Section 274-a of New York State Town Law that this Town Board approves the proposed site plan subject to:

1. The Town Engineer Approving a Flood Plain Development Permit for the addition.

RESULT:	ADOPTED [UNANIMOUS]
MOVER:	Diane Benczkowski, Councilmember
SECONDER:	James P. Rogowski, Councilmember
AYES:	Rogowski, Kaminski, Wozniak, Benczkowski, Meyers
ABSENT:	Mary Holtz



6. RESOLUTION 2014-533

Approve Special Use Permit & Variance - 2013 Walden Avenue

Sponsored By: Councilmember Benczkowski, Councilmember Meyers

WHEREAS, Benderson Development Company, LLC has applied for a Special Use Permit to establish an accessory drive through window for a proposed restaurant/cafe on property owned by Buffalo WVP Associates, LLC and located at 2013 Walden Avenue, Cheektowaga, New York, pursuant to Sections 260-47 and 260-48.2 of the Code of the Town of Cheektowaga ("Zoning Law"); and

WHEREAS, Benderson Development Company, LLC also requested a variance to reduce the number of vehicle queues from sixteen (16) to seven (7), and

WHEREAS, a public hearing was held before the Cheektowaga Town Board on the 15th day of September, 2014 at 6:45 P.M. of said day for the purpose of considering said applications for a Special Permit and variances from the Zoning Law, after publication and service of the notices required by the provisions of the Zoning Law and the Town Law; and all interested parties were given an opportunity to be heard at such hearing; and

WHEREAS, the Cheektowaga Planning Board has recommended approval of this Special Permit and variance; and

WHEREAS, this Town Board previously issued a Negative Declaration under SEQRA for this project; NOW, THEREFORE BE IT

RESOLVED, that the aforesaid Special Use Permit be and hereby is granted, and BE IT FURTHER

RESOLVED, that this Town Board hereby grants the aforementioned variance relating to the reduction in the vehicle queue from sixteen (16) to seven (7).

RESULT:	WITHDRAWN
----------------	------------------



7. RESOLUTION 2014-534

Call for Public Hearing - Rezoning Request Part of 2525 and 2535 Walden Avenue

Sponsored By: Councilmember Benczkowski, Councilmember Rogowski

WHEREAS, Benderson Development Company, LLC has made application and requested the rezoning of a portion of 2525 and 2535 Walden Avenue from M1- Light Manufacturing to CM- General Commercial to permit the re-development of an existing warehouse / office development; to include the demolition of an existing 91,655 s.f. warehouse, and the construction of a 13,090 s.f. office building, a new 78,486 s.f. warehouse building, and the re-utilization of an existing 21,041 s.f. warehouse building for retail sales, NOW, THEREFORE BE IT

RESOLVED, that a Public Hearing be held regarding said request under the provisions of the Zoning Law on October 20, 2014 at 6:45 P.M., at the Cheektowaga Town Hall, 3301 Broadway at the corner of Union Road.



Notice of Public Hearing

NOTICE IS HEREBY GIVEN that a Public Hearing will be held by the Town Board of the Town of Cheektowaga, Erie County, New York at the Town Hall in the said Town of Cheektowaga, 3301 Broadway corner of Union Road on the 20th of October, 2014 at 6:45 o'clock P.M., of said day for the purpose of considering the application of:

Benderson Development Co., LLC

For the rezoning of rezoning of a portion of 2525 and 2535 Walden Avenue from M1- Light Manufacturing to CM- General Commercial to permit the re-development of an existing warehouse / office development; to include the demolition of an existing 91,655 s.f. warehouse, and the construction of a 13,090 s.f. office building, a new 78,486 s.f. warehouse building, and the re-utilization of an existing 21,041 s.f. warehouse building for retail sales.

All parties in interest and citizens will be given an opportunity to be heard in regard to such proposed application.

BY ORDER OF THE TOWN BOARD, Town of Cheektowaga, NY

Alice Magierski, TOWN CLERK



All that tract or parcel of land situate in Town of Cheektowaga, County of Erie, and State of New York, ALL THAT TRACT OR PARCEL OF LAND situate in the Town of Cheektowaga, County of Erie and State of New York, being part of Lot No. 11, Township 11, Range 7 of the

Holland Land Company's Survey, bounded and described as follow:

Beginning at the point of intersection of the south line of Walden Avenue Extension with the west line of the lands conveyed to Latrobe Steel Company by deed dated July 25, 1955 and recorded in the Erie County Clerk's Office in Liber 5795 of Deeds at page 461; Thence S01°04'46"E along said west line of the lands conveyed by Deed aforesaid, a distance of 345.98 feet to a point; Thence S88°55'14"W, a distance of 333.06 feet to a point; Thence N01°04'46"W parallel with the east line of premises herein described, a distance of 291.32 feet to the south line of Walden Avenue Extension; Thence N79°36'03"E along the south line of Walden Avenue Extension, a distance of 337.52 feet to the point or place of beginning.

Parcel containing 2.436 acres of land, more or less.

RESULT:	ADOPTED [UNANIMOUS]
MOVER:	Diane Benczkowski, Councilmember
SECONDER:	James P. Rogowski, Councilmember
AYES:	Rogowski, Kaminski, Wozniak, Benczkowski, Meyers
ABSENT:	Mary Holtz



8. RESOLUTION 2014-535

Call for Public Hearing for Community Development Funds

Sponsored By: Councilmember Benczkowski, Councilmember Kaminski

WHEREAS, the Town of Cheektowaga is eligible to receive funding from the Department of Housing and Urban Development under the Community Development Block Grant and HOME Investment Partnerships Programs for the 2015 Program Year, and

WHEREAS, as recipients of federal CDBG and HOME program assistance from HUD, the Town is required to complete a Consolidated Plan once every five years; the purpose of which is to identify the priority housing and community development needs throughout the Town of Cheektowaga and identify the activities that the Town will carry-out during the next five program years, and

WHEREAS, the Town of Cheektowaga is required to prepare and submit to the Department of Housing and Urban Development an Annual Plan which identifies the activities that the Town will carry-out during the next program year, and

WHEREAS, the Town is required to hold public hearings to obtain the views of Town residents, public agencies and other interested parties on housing and community development needs, to identify additional proposed activities, and to review program performance during the previous program year, NOW, THEREFORE, BE IT

RESOLVED, that a public hearing be held on October 20, 2014 at 6:45 P.M. at Cheektowaga Town Hall, 3301 Broadway at Union Road, Cheektowaga, NY 14227 for the above stated purpose, and BE IT

FURTHER RESOLVED, that a public notice of such public hearing be published in the Cheektowaga Bee.



Notice of Public Hearing
Town of Cheektowaga FY 2015-2019 Consolidated Plan
And FY 2015 Annual Plan
Community Development Block Grant/HOME Programs

A Public Hearing will be held on Monday, October 20, 2014 at 6:45 P.M. at Cheektowaga Town Hall, 3301 Broadway, Cheektowaga, New York, regarding the Town of Cheektowaga's FY 2015-2019 Consolidated Plan and FY 2015 Annual Plan for the Community Development Block Grant (CDBG) and HOME Investment Partnership (HOME) Programs.

The amount of CDBG and HOME funding for which the Town will be eligible next year has not yet been determined by the Department of Housing and Urban

Development (HUD). In 2014, the Town received \$943,802 in CDBG funds and \$226,030 in HOME funds. The purpose of the hearing is to solicit the views of citizens, public agencies and other interested parties on housing and community development needs throughout the Town, develop proposed activities and to review program performance of the Town's Community Development Program. A complete listing of eligible activities can be obtained from the Town's Community Development Office at the address listed below. Funded eligible activities have included the rehabilitation of residences owned by low-income residents, services to seniors and low-income youth, as well as counseling for homebuyers, those at risk for foreclosure, financial education and victims of domestic violence.

Residents of low income neighborhoods and all citizens of the Town and Villages are encouraged to participate and express their views on the use of funds and activities that may be carried out with program funds. Although not likely, CDBG or HOME funded activities may result in displacement. In the event displacement due to CDBG or HOME funded activities occurs, relocation assistance will be provided in conformity with the requirements of the Uniform Relocation Act of 1970, implementing regulations in 24 CFR Part 42, and regulations governing the CDBG program at 24 CFR 570.606.

Upon prior request, an interpreter will be made available at the hearing to sign for the hearing impaired. Please contact the Cheektowaga Community Development Office (716-897-7200) seven days prior to the hearing if you need such special arrangements or have language issues which need to be addressed. The hearing location is accessible to the physically disabled. Written comments may be submitted to the Town of Cheektowaga Office of Community Development, 275 Alexander Avenue, Cheektowaga, New York, 14211.

RESULT:	ADOPTED [UNANIMOUS]
MOVER:	Diane Benczkowski, Councilmember
SECONDER:	Gerald Kaminski, Councilmember
AYES:	Rogowski, Kaminski, Wozniak, Benczkowski, Meyers
ABSENT:	Mary Holtz



9. RESOLUTION 2014-536

Call for Public Hearing to Extend Pine Hill Fire District No. 5

Sponsored By: Councilmember Rogowski, Councilmember Kaminski

WHEREAS, for years, property known as the Buffalo Drive-In on Harlem Road in the Town of Cheektowaga was not within any fire district, and

WHEREAS, Cleveland Hill Fire District No. 6 and Pine Hill Fire District No. 5 have agreed to divide this property so that each district will be extended to service a portion of this property, and

WHEREAS, additional properties which were not within any district (cemetery properties) will also become included within the Pine Hill Fire District No. 5 territory, and

WHEREAS, the Town Board of the Town of Cheektowaga, New York (the "Town") deems it advisable that Pine Hill Fire District No. 5 be extended to include the territory described in the attached sheets,

NOW, THEREFORE, BE IT RESOLVED, that this Town Board shall meet at the Town Hall, 3301 Broadway, Cheektowaga, New York on the 20th day of October, 2014 at 6:45 P.M. to discuss and hear all persons interested in the matter of the extension of Pine Hill Fire District No. 5, and BE IT FURTHER

RESOLVED, that the Town Clerk is hereby authorized and directed to publish notice of said hearing in the CHEEKTOWAGA BEE, the official newspaper of the Town, and to post copies of said notice in the following locations as provided by law.:

- on the signboard
- conspicuously in locations within the area of the proposed extension
- on the Town website
- with the New York State Comptroller's Office (certified copy)



LEGAL NOTICE EXTENSION OF PINE HILL FIRE DISTRICT NO. 5

NOTICE IS HEREBY GIVEN THAT the Town Board of the Town of Cheektowaga will meet at the Cheektowaga Town Hall Council Chambers in the Cheektowaga Town Hall, 3301 Broadway, Cheektowaga, New York 14227 on the 20th day of October, 2014 for the purpose of considering the proposed extension of the boundaries of Pine Hill Fire District No. 5 of the Town of Cheektowaga. All interested persons will be given an opportunity to comment on said proposed fire district boundary extension.

The estimated tax rate per thousand dollars of assessed valuation of the proposed

district extension is \$4.152312.

A copy of the legal descriptions for the LANDS PROPOSED TO BE INCLUDED IN THE PINE HILL FIRE DISTRICT and DESCRIPTION OF PROPOSED PINE HILL FIRE DISTRICT NO. 5 WITH ADDITIONAL LANDS are described on the attached sheets.

BY ORDER OF THE TOWN BOARD OF THE TOWN OF CHEEKTOWAGA, ERIE COUNTY, NEW YORK.

October 6, 2014

Alice Magierski, Town Clerk

Attachments:

07J2-0287 Pine Hill FD5- additional lands 2014 REV-2 (DOC)

07J2-0287 Pine Hill FD5- overall additional lands 2014 REV-4 (DOC)

RESULT:	ADOPTED [UNANIMOUS]
MOVER:	James P. Rogowski, Councilmember
SECONDER:	Gerald Kaminski, Councilmember
AYES:	Rogowski, Kaminski, Wozniak, Benczkowski, Meyers
ABSENT:	Mary Holtz



10. RESOLUTION 2014-537

Call for Public Hearing to Extend Cleveland Hill Fire District No. 6

Sponsored By: Councilmember Rogowski, Councilmember Meyers

WHEREAS, for years, property known as the Buffalo Drive-In on Harlem Road in the Town of Cheektowaga was not within any fire district, and

WHEREAS, Cleveland Hill Fire District No. 6 and Pine Hill Fire District No. 5 have agreed to divide this property so that each district will be extended to service a portion of this property, and

WHEREAS, additional properties which were not within any district (cemetery properties and the southwest corner of Maryvale Drive and Harlem Road) will also become included within the Cleveland Hill Fire District No. 6 territory, and

WHEREAS, the Town Board of the Town of Cheektowaga, New York (the "Town") deems it advisable that Cleveland Hill Fire District No. 6 be extended to include the territory described in the attached documents,

NOW, THEREFORE, BE IT RESOLVED, that this Town Board shall meet at the Town Hall, 3301 Broadway, Cheektowaga, New York on the 20th day of October, 2014 at 6:45 P.M. to discuss and hear all persons interested in the matter of the extension of Cleveland Hill Fire District No. 6, and BE IT FURTHER

RESOLVED, that the Town Clerk is hereby authorized and directed to publish notice of said hearing in the CHEEKTOWAGA BEE, the official newspaper of the Town, and to post copies of said notice in the following locations as provided by law.:

- on the signboard
- conspicuously in locations within the area of the proposed extension
- on the Town website
- with the New York State Comptroller's Office (certified copy)



LEGAL NOTICE OF PUBLIC HEARING EXTENSION OF CLEVELAND HILL FIRE DISTRICT NO. 6

NOTICE IS HEREBY GIVEN THAT, the Town Board of the Town of Cheektowaga will meet at the Cheektowaga Town Hall Council Chambers in the Cheektowaga Town Hall, 3301 Broadway, Cheektowaga, New York 14227 on the 20th day of October, 2014 for the purpose of considering the proposed extension of the boundaries of Cleveland Hill Fire District No. 6 of the Town of Cheektowaga. All interested persons will be given an opportunity to comment on said proposed fire district boundary extension.

The estimated tax rate per thousand for said proposed district extension is \$2.254050.

A copy of the legal descriptions for LANDS PROPOSED TO BE INCLUDED IN THE CLEVELAND HILL FIRE DISTRICT and DESCRIPTION OF PROPOSED CLEVELAND HILL FIRE DISTRICT NO. 6 WITH ADDITIONAL LANDS are described on the attached sheets.

BY ORDER OF THE TOWN BOARD OF THE TOWN OF CHEEKTOWAGA, ERIE COUNTY, NEW YORK.

Dated: October 6, 2014

ALICE MAGIERSKI, Town Clerk

Attachments:

07J2-0287 Cleveland Hill FD6- additional lands 2014 REV-3 (DOC)

07J2-0287 Cleveland Hill FD6- overall with additional lands REV-5(DOC)

RESULT:	ADOPTED [UNANIMOUS]
MOVER:	James P. Rogowski, Councilmember
SECONDER:	Timothy J. Meyers, Councilmember
AYES:	Rogowski, Kaminski, Wozniak, Benczkowski, Meyers
ABSENT:	Mary Holtz



11. RESOLUTION 2014-538

Call for Public Hearing - 2015 Preliminary Ad Valorem Budget

Sponsored By: Councilmember Kaminski, Councilmember Rogowski

RESOLVED, that this Town Board does hereby prepare and approve as the Preliminary Ad Valorem Budget of this Town for the Fiscal Year beginning on the 1st day of January, 2015, the itemized statement of estimated revenues and expenditures, and also an itemized statement of estimated revenues and expenditures of the Lighting Districts and Consolidated Garbage District, AND, BE IT FURTHER

RESOLVED, that such Preliminary Ad Valorem Budget and the Lighting Districts and Consolidated Garbage District Budgets shall be filed in the Office of the Town Clerk where it shall be available for inspection by any interested person at all reasonable hours, effective October 1, 2014, AND, BE IT FURTHER

RESOLVED, that this Town Board shall meet at 5:30 P.M. on the 28th day of October, 2014, for the purpose of holding a Public Hearing upon such Preliminary Ad Valorem Budget and the Lighting Districts and Consolidated Garbage District budgets, AND, BE IT FURTHER

RESOLVED, that the Town Clerk give Notice of such Public Hearing in the manner provided in Section 108 of the Town Law and that such Notice be published in the CHEEKTOWAGA BEE, the official Town newspaper on October 16, 2014, and post same on the signboard maintained by the Town Clerk.



LEGAL NOTICE

of

PUBLIC HEARING

on

PRELIMINARY AD VALOREM BUDGET

and

LIGHTING DISTRICTS and CONSOLIDATED GARBAGE DISTRICT BUDGETS

NOTICE IS HEREBY GIVEN that the Preliminary Ad Valorem Budget of the Town of Cheektowaga and the Lighting Districts and Consolidated Garbage District Budgets for the Fiscal Year beginning January 1, 2015, has been completed and filed in the Office of the Town Clerk at the Town Hall, corner of Broadway and Union Roads, Cheektowaga, New York where it

is available for inspection by any interested person at all reasonable hours, effective October 1, 2014.

FURTHER NOTICE IS HEREBY GIVEN that the Town Board of the Town of Cheektowaga will meet and review said Preliminary Ad Valorem Budget and the Lighting Districts and Consolidated Garbage District Budgets and hold a Public Hearing thereon at the Town Hall, corner of Broadway and Union Roads, Cheektowaga, New York at 5:30 P.M. on the 28th day of October, 2014 and that at such hearing any person may be heard in favor or against the Preliminary Ad Valorem Budget and the Lighting Districts and Consolidated Garbage District Budget as compiled for or against any item therein contained.

Pursuant to Section 108 of the Town Law, the proposed salaries of the Town Officers are hereby specified as follows:

SUPERVISOR	\$79,140
TOWN CLERK	\$80,960
HIGHWAY SUPERINTENDENT	\$83,790
COUNCILMEMBER(6)	\$20,680
TOWN JUSTICE(2)	\$74,960

BY ORDER OF THE TOWN BOARD OF THE TOWN OF CHEEKTOWAGA, ERIE COUNTY, NEW YORK

ALICE MAGIERSKI,
TOWN CLERK

Dated: October 6, 2014
Published: October 16, 2014

RESULT:	ADOPTED [UNANIMOUS]
MOVER:	Gerald Kaminski, Councilmember
SECONDER:	James P. Rogowski, Councilmember
AYES:	Rogowski, Kaminski, Wozniak, Benczkowski, Meyers
ABSENT:	Mary Holtz



12. RESOLUTION 2014-539

Call for Public Hearing - 2015 Benefit Basis Budget

Sponsored By: Councilmember Kaminski, Councilmember Rogowski

WHEREAS, this Town Board has prepared detailed estimates of the anticipated 2015 revenues and expenditures for every district in which the expenses of the improvement are to be assessed on a benefit basis, AND

WHEREAS, this Town Board has assessed the Special District costs on a benefit basis against the lots or parcels of land against which the improvement was chargeable, AND

WHEREAS, this Town Board had prepared an assessment roll for each district describing each lot of land in the district, the owner thereof, and the assessment levied against it, AND

WHEREAS, this Town Board has filed such estimates and assessment rolls with the Town Clerk, NOW, THEREFORE, BE IT

RESOLVED, that this Town Board shall meet at 5:30 P.M. on the 28th day of October, 2014 for the purpose of holding a Public Hearing upon such estimates and assessment rolls, AND, BE IT FURTHER

RESOLVED, that the Town Clerk give notice of such Public Hearing in the manner provided in Section 239 of the Town Law, and that such notice be published in substantially the following form in the CHEEKTOWAGA BEE, the official Town newspaper on October 16, 2014.



PUBLIC NOTICE

NOTICE IS HEREBY GIVEN that the Town Board of the Town of Cheektowaga, New York has completed its Estimates and Assessment Rolls relating to Special Districts spreading costs on a Benefit Basis and has filed same with the Town Clerk.

NOTICE IS ALSO GIVEN that a public hearing on such Estimates and Assessment Rolls will be held on Tuesday, October 28, 2013 at 5:30 P.M. at the Town Hall, corner of Broadway and Union Roads, at which time the Town Board will meet to hear and consider any objections which shall be made to such Estimates and Assessment Rolls.

BY ORDER OF THE TOWN BOARD OF THE TOWN OF CHEEKTOWAGA, ERIE COUNTY,
NEW YORK

Alice Magierski, Town Clerk

Dated: October 6, 2014
Published: October 16, 2014

RESULT: **ADOPTED [UNANIMOUS]**
MOVER: Gerald Kaminski, Councilmember
SECONDER: James P. Rogowski, Councilmember
AYES: Rogowski, Kaminski, Wozniak, Benczkowski, Meyers
ABSENT: Mary Holtz



13. RESOLUTION 2014-540

Notice of Hearing for Demolition of 36 Barbara Place

Sponsored By: Councilmember Benczkowski, Councilmember Meyers

WHEREAS, the Supervising Code Enforcement Officer has received information that the building located at **36 Barbara Place in the Town of Cheektowaga (S.B.L. No. 101.28-1-3)** has become dangerous and unsafe to the general public and unfit for the purposes for which it may lawfully be used; and

WHEREAS, said building has been inspected and a written report of the condition has been completed by Nussbaumer & Clarke, Inc., duly authorized agent of the Town of Cheektowaga, setting forth its findings and recommendations in regard to the repair or demolition and removal of the building, and said written report describes extensive deterioration and damage to the building and premises and recommends that the building be demolished and removed as soon as possible; and

WHEREAS, the Town Board has fully considered such written report and has determined that the building is dangerous and unsafe to the general public and unfit for the purposes for which it may lawfully be used; NOW THEREFORE BE IT

RESOLVED, that this Town Board accepts the findings and recommendations of Nussbaumer & Clarke, Inc., dated **March 11, 2014**; and BE IT FURTHER

RESOLVED, that a notice shall be served, pursuant to Section 75-7 of the Cheektowaga Town Code, upon the owner, executor, administrator, agent, lessee or any person having a vested or contingent interest in such unsafe building as shown by the records of the Receiver of Taxes or of the County Clerk, which notice shall have the contents prescribed by Section 75-6 of said Town Code, including, but not limited to a date, time and place for a hearing before the Town Board in relation to such dangerous and unsafe building, which hearing shall be scheduled not less than five business days from the date of service of the notice; and BE IT FURTHER

RESOLVED, that a hearing before this Board in relation to this dangerous and unsafe building shall be held on the **20th day of October, 2014 at 6:45 P.M.** at the Cheektowaga Town Hall, 3301 Broadway, Cheektowaga, New York, and BE IT FURTHER

RESOLVED, that the Code Enforcement Office and/or the Town Attorney's Office be and hereby are directed to serve notice of said hearing on all interested parties.

RESULT:	ADOPTED [UNANIMOUS]
MOVER:	Diane Benczkowski, Councilmember
SECONDER:	Timothy J. Meyers, Councilmember
AYES:	Rogowski, Kaminski, Wozniak, Benczkowski, Meyers
ABSENT:	Mary Holtz



14. RESOLUTION 2014-541

Notice of Hearing for Demolition of 36 Peachrow Lane

Sponsored By: Councilmember Benczkowski, Councilmember Meyers

WHEREAS, the Supervising Code Enforcement Officer has received information that the building located at **36 Peachrow Lane in the Town of Cheektowaga (S.B.L. No. 91.06-11-32)** has become dangerous and unsafe to the general public and unfit for the purposes for which it may lawfully be used; and

WHEREAS, said building has been inspected and a written report of the condition has been completed by Nussbaumer & Clarke, Inc., duly authorized agent of the Town of Cheektowaga, setting forth its findings and recommendations in regard to the repair or demolition and removal of the building, and said written report describes extensive deterioration and damage to the building and premises and recommends that the building be demolished and removed as soon as possible; and

WHEREAS, the Town Board has fully considered such written report and has determined that the building is dangerous and unsafe to the general public and unfit for the purposes for which it may lawfully be used; NOW THEREFORE BE IT

RESOLVED, that this Town Board accepts the findings and recommendations of Nussbaumer & Clarke, Inc., dated **July 31, 2014**; and BE IT FURTHER

RESOLVED, that a notice shall be served, pursuant to Section 75-7 of the Cheektowaga Town Code, upon the owner, executor, administrator, agent, lessee or any person having a vested or contingent interest in such unsafe building as shown by the records of the Receiver of Taxes or of the County Clerk, which notice shall have the contents prescribed by Section 75-6 of said Town Code, including, but not limited to a date, time and place for a hearing before the Town Board in relation to such dangerous and unsafe building, which hearing shall be scheduled not less than five business days from the date of service of the notice; and BE IT FURTHER

RESOLVED, that a hearing before this Board in relation to this dangerous and unsafe building shall be held on the **20th day of October, 2014 at 6:45 P.M.** at the Cheektowaga Town Hall, 3301 Broadway, Cheektowaga, New York, and BE IT FURTHER

RESOLVED, that the Code Enforcement Office and/or the Town Attorney's Office be and hereby are directed to serve notice of said hearing on all interested parties.

RESULT:	ADOPTED [UNANIMOUS]
MOVER:	Diane Benczkowski, Councilmember
SECONDER:	Timothy J. Meyers, Councilmember
AYES:	Rogowski, Kaminski, Wozniak, Benczkowski, Meyers
ABSENT:	Mary Holtz



15. RESOLUTION 2014-542

Notice to Bidders for Furnishing Equipment and Operators for the Clean-Up and Board-Up of Various Properties (BID 2014-32 CD)

Sponsored By: Councilmember Benczkowski, Councilmember Kaminski

WHEREAS, under the direction of the Community Development Department, the Office of Housing & Neighborhood Preservation is responsible for inspecting various properties within the Town of Cheektowaga to ensure compliance with residential and commercial property maintenance codes, and

WHEREAS, maintenance of these properties sometimes includes boarding up/securing structures and minor demolition of structures and other related work, and

WHEREAS, when violations are noted, property owners are notified to maintain and secure their properties, and

WHEREAS, in the event property owners do not comply with these orders from the Housing & Neighborhood Preservation Office, and public health and safety require that action be taken immediately, it is necessary that the Housing & Neighborhood Preservation Office retain a private contractor to perform the necessary work on the property, and

WHEREAS, due to the projected annual cost for performing this work, it is necessary that this Board advertise for bids for these services, and

WHEREAS, the Building Inspections Department, Housing & Neighborhood Preservation Office, and the Town Attorney's Office have drafted bid specifications for this purpose for the remainder of calendar year 2014 plus calendar year 2015, NOW, THEREFORE, BE IT

RESOLVED, that the Town Clerk be and hereby is directed to publish a Notice to Bidders for Furnishing Equipment and Operators for the Clean Up and Board Up of Various Properties in the Town of Cheektowaga (BID 2014-32 CD) in the Cheektowaga Bee, and BE IT FURTHER

RESOLVED, that bids will be received until October 15, 2014 at 11:00 a.m. by the Town Clerk, who is hereby authorized and directed to publicly open all bids received at such time in the Council Chambers in the Cheektowaga Town Hall.



NOTICE TO BIDDERS

Sealed proposals will be received and considered by the Town Board of the Town of Cheektowaga on October 15, 2014 at 11:00 A.M., at the Town Hall, corner of Broadway and Union Roads, for Furnishing Equipment and Operators for the Clean-Up and Board-Up of

Various Properties in the Town of Cheektowaga for the Remainder of Calendar Year 2014 Plus Calendar Year 2015, said services to include installation of padlocks and latches; boarding up of openings, removal of garbage/rubbish and debris, demolitions of minor structures such as sheds, porches, etc.

Information for bidders and specifications may be obtained from the Town Clerk at her office in said Town Hall.

Proposals shall be submitted in a sealed envelope plainly marked on the outside "Bid for Furnishing of Equipment and Operators for the Clean-Up and Board-Up of Various Properties in the Town of Cheektowaga for the Remainder of Calendar Year 2014 Plus Calendar Year 2015 (2014-32 CD)" and submitted to the Town Clerk prior to bid opening.

No bidder may withdraw his bid within forty-five (45) days after the actual date of the opening thereof.

The Town Board reserves the right to consider informal any bid not prepared and submitted in accordance with the provisions of the specifications and contract documents, and may waive any informalities, make an award to other than the low bidder, should it be in the best interest of the Town, or reject any or all bids.

Each proposal must be accompanied by a certified check for a sum equal to five percent (5%) of the amount of the bid, payable to the Town of Cheektowaga, New York, or bond with sufficient sureties to be approved by the attorney for the Town of Cheektowaga, New York.

By order of the Town Board of the Town of Cheektowaga, Erie County, New York.

Alice Magierski, Town Clerk

RESULT:	ADOPTED [UNANIMOUS]
MOVER:	Diane Benczkowski, Councilmember
SECONDER:	Gerald Kaminski, Councilmember
AYES:	Rogowski, Kaminski, Wozniak, Benczkowski, Meyers
ABSENT:	Mary Holtz



16. RESOLUTION 2014-543

Authorize Supervisor to Execute Agreement for Electronic Waste Recycling for Residents

Sponsored By: Councilmember Kaminski, Councilmember Rogowski

WHEREAS, on a regular basis, residents of the Town of Cheektowaga need to dispose of their obsolete and non-operational televisions, computers, monitors, printers, drives, fax machines and other electronic items, all of which contain hazardous materials (i.e., lead, mercury, etc.) and all of which must be disposed of in an environmentally sound manner; and

WHEREAS, Electronic Recyclers International, Inc., with a corporate office in Fresno, California, an electronics recycling company, is desirous of picking up and properly disposing of CRT's, televisions, monitors, laptops, computers, and other electronic devices dropped off by residents at the Highway Department (or other location), in full compliance with all government regulations applicable to the disposal of hazardous waste, at no cost to the Town for said pickup, removal, and disposal and, in exchange for said free pickup and disposal, the Town will not collect payment for any recovered materials; NOW, THEREFORE, BE IT

RESOLVED, that the Town hereby authorizes the Town Superintendent of Highways or other Town department to set up a system for Electronic Recyclers International, Inc., or their local designee, to take possession of the discarded computer and electronic equipment dropped off on Town property by Town residents, and dispose of same in full compliance with all applicable federal and state regulations governing the disposal of hazardous waste; and BE IT FURTHER

RESOLVED, that, subject to review and approval by the Town Attorney, the Supervisor be and hereby is authorized to execute an agreement and any other documents necessary effect the proper disposal of said equipment.

RESULT:	ADOPTED [UNANIMOUS]
MOVER:	Gerald Kaminski, Councilmember
SECONDER:	James P. Rogowski, Councilmember
AYES:	Rogowski, Kaminski, Wozniak, Benczkowski, Meyers
ABSENT:	Mary Holtz



17. RESOLUTION 2014-544

Authorize Supervisor to Execute Agreement with Twin Village Salvage, Inc.

Sponsored By: Councilmember Kaminski, Councilmember Rogowski

WHEREAS, the Town of Cheektowaga regularly collects scrap metal which is placed at the curb by Town residents for disposal by the Town; and

WHEREAS, other Town departments, on occasion, have scrap metal which is surplus to the needs of the Town and needs to be disposed of; and

WHEREAS, Twin Village Recycling, Inc., (Twin Village) of Depew, New York, has submitted a proposal to the Town whereby it will provide removal and recycling services of said scrap metal and charge no fees to the Town and will provide free scale certification for all Town trucks and trailers that may occasionally deliver scrap to Twin Village, thus saving the Town approximately \$3,500.00 annually; and

WHEREAS, Twin Village will remit to the Town monies it receives from the sale of recycled scrap metal on or before the 30th day from the date material is received; and

WHEREAS, payments from Twin Village to the Town will be calculated as follows: Ferrous metal is priced monthly based on volume and grade verification; non-ferrous metal is priced daily due to market fluctuation, grade verification and volume; the market values submitted by Twin Village in its proposal, being current and competitive, are as follows:

- Ferrous Sheet/Shear \$230.00 NT
- Ferrous Cast/MHS1 \$280.00 NT
- Non-Ferrous Aluminum \$ 0.57 LB Clean
- Non-Ferrous Irony Aluminum \$ 0.18 LB

NOW, THEREFORE, BE IT

RESOLVED, that this Town Board hereby accepts the proposal of Twin Village Recycling, Inc., 4153 Broadway, Depew, New York, 14043, for the recycling of Town scrap metal as herein described; and BE IT FURTHER

RESOLVED, that the Supervisor is hereby authorized and directed to execute an agreement with Twin Village Recycling, Inc., or any other documents that may be required, in accordance with the above.

RESULT:	ADOPTED [UNANIMOUS]
MOVER:	Gerald Kaminski, Councilmember
SECONDER:	James P. Rogowski, Councilmember
AYES:	Rogowski, Kaminski, Wozniak, Benczkowski, Meyers
ABSENT:	Mary Holtz



18. RESOLUTION 2014-545

Authorize Supervisor to Execute License Agreement with 7K Unlimited, Inc.

Sponsored By: Councilmember Rogowski, Councilmember Wozniak

WHEREAS, the Town of Cheektowaga entered into a License Agreement and subsequent Amendment with Ice Time of W.N.Y., Ltd., (now known as 7K Unlimited, Inc.) for the operation of a Pro-shop and Concession Stand at the ice rink in the Town of Cheektowaga Recreation Center and for the installation of vending machines in various Town-owned buildings, which Agreement has since expired; and

WHEREAS, 7K Unlimited, Inc., has requested permission to again operate said Pro-shop and Concession Stand at the ice rink in the Town of Cheektowaga Recreation Center, for which 7K Unlimited, Inc., shall pay rent to the Town in the amount of \$750.00 each month in the months of January, February, March, October, November, and December, beginning on October 1, 2014 and ending on October 31, 2016, and shall charge no more than \$2.00 per pair for the rental of ice skates; and

WHEREAS, 7K Unlimited, Inc. will also provide vending machines at the Town of Cheektowaga Recreation Center, and

WHEREAS, the Town Attorney has prepared a draft of said License Agreement; NOW, THEREFORE, BE IT

RESOLVED, that the Supervisor be and hereby is authorized and directed to execute this License Agreement with 7K Unlimited, Inc., on behalf of the Town.

RESULT:	ADOPTED [UNANIMOUS]
MOVER:	James P. Rogowski, Councilmember
SECONDER:	Angela M. Wozniak, Councilmember
AYES:	Rogowski, Kaminski, Wozniak, Benczkowski, Meyers
ABSENT:	Mary Holtz



19. RESOLUTION 2014-546

Renewal of Lease of ORF Site with County of Erie

Sponsored By: Councilmember Rogowski, Councilmember Wozniak

WHEREAS, the Town of Cheektowaga currently has an agreement with the County of Erie to lease County-owned property located on the south side of Cayuga Creek Road and north of Cayuga Creek (the "ORF Site") for open green space/parkland, drainage and miscellaneous uses, and

WHEREAS, this lease will expire on December 31, 2014, and

WHEREAS, the County of Erie has offered to renew said lease for another five (5) years with an optional additional five (5) year renewal for \$500 per year, and

WHEREAS, this Town Board desires to continue said lease agreement with the County of Erie, NOW, THEREFORE, BE IT

RESOLVED, that the Supervisor be and hereby is authorized and directed to execute the lease agreement with the County of Erie for the ORF Site, and BE IT FURTHER

RESOLVED, that lease payments shall be appropriated from budget line item number 100-7110-4433.

RESULT:	ADOPTED [UNANIMOUS]
MOVER:	James P. Rogowski, Councilmember
SECONDER:	Angela M. Wozniak, Councilmember
AYES:	Rogowski, Kaminski, Wozniak, Benczkowski, Meyers
ABSENT:	Mary Holtz



20. RESOLUTION 2014-547

Support For The Niagara Military Affairs Council's Efforts For The Niagara Falls Air Reserve Station

Sponsored By: Councilmember Meyers, Councilmember Rogowski

WHEREAS, the Niagara Military Affairs Council is an organization whose mission is preserve the active status of the Niagara Falls Air Reserve Station, and

WHEREAS, the Niagara Falls Air Reserve Station is home to the United States Air Force 914th Airlift Wing; the 107th New York Air National Guard; the Military Enlistment Processing Station; the 277th Quartermaster Company Army Reserve; the 2nd Squadron of the 101st Cavalry New York Army National Guard; the 865th Army Combat Support Hospital, Army Reserve; and the 1982nd Forward Surgical Team Army Reserve, and

WHEREAS, the NFTA through a joint Use Agreement with the United States Government work together to maintain the integrity of the Niagara Falls International Airport airfield, ensuring that aviation missions essential to the security of our nation can be conducted, and

WHEREAS, the Niagara Falls Air Reserve Station is Niagara County's largest employer and provides significant economic and social benefits to all of Western New York, NOW THEREFORE BE IT

RESOLVED, that the Cheektowaga Town Board supports the work of the Niagara Military Affairs Council in their efforts to support the growth and prosperity of the Niagara Falls Air Reserve Station and its personnel thereby creating a positive impact on all the local Erie County governments and the Western new York Community, and BE IT FURTHER

RESOLVED, that this Town Board hereby directs the Town Clerk to communicate the Town's support for the goals of the Niagara Military Affairs Council and to support the work of NIMAC to fulfill its mission.

RESULT:	ADOPTED [UNANIMOUS]
MOVER:	Timothy J. Meyers, Councilmember
SECONDER:	James P. Rogowski, Councilmember
AYES:	Rogowski, Kaminski, Wozniak, Benczkowski, Meyers
ABSENT:	Mary Holtz



21. RESOLUTION 2014-548

Support for Statewide Campaign to Recover More Textiles From the Waste Stream

Sponsored By: Councilmember Kaminski, Councilmember Meyers

WHEREAS, the Town of Cheektowaga operates a successful recycling program for the Town of Cheektowaga residents and businesses with a goal to reduce, reuse and recycle components of the waste stream in order to benefit the environment; and

WHEREAS, the Town of Cheektowaga is supportive of expanding recycling efforts in New York State that capture and reuse waste items that would otherwise be disposed of as solid waste; and

WHEREAS, the United States Environmental Protection Agency estimates that only about 15% of unwanted textiles, including clothing, shoes, hats, linens, towels and belts, are donated for reuse or recycling, the remaining 85% is simply trashed, estimated at 70 pounds per citizen per year; and

WHEREAS, the Town of Cheektowaga has recognized that the New York State Association for Reduction, Reuse and Recycling (NYSAR) is teaming up with the Council for Textile Recycling (CTR), and the Association of Wiping Materials, Used Clothing and Fiber Industries, also known as Secondary Materials and Recycled Textiles (SMART), to launch a first-of-its-kind statewide textile recovery campaign in New York State aimed at recovering 1.4 billion pounds of textiles trashed annually in New York State, with a market value of \$200 million, by:

- Increasing awareness for the need to increase textile recovery and recycling and reducing wasteful textile disposal practices,
- Enhancing job development through the recovery of more materials, and
- Promoting collaboration between key textile recovery stakeholders, including collectors, recyclers, retailers, and municipal recycling professionals; and

WHEREAS, the Town of Cheektowaga wishes to take a leadership role in recycling efforts to reduce solid waste and recycle those components of the waste stream in order to benefit the environment by promoting textile recovery efforts, and communicating the environmental, economic, and social benefits of increased textile recovery; **NOW, THEREFORE, BE IT**

RESOLVED, that the Town of Cheektowaga does hereby express its strong support of a Statewide campaign to recover more textiles from the waste stream and to thereby reduce waste that would otherwise end up in the solid waste stream by promoting textile recovery efforts and communicating the environmental, economic and social benefits of increased textile recovery.

RESULT:	ADOPTED [UNANIMOUS]
MOVER:	Gerald Kaminski, Councilmember
SECONDER:	Timothy J. Meyers, Councilmember
AYES:	Rogowski, Kaminski, Wozniak, Benczkowski, Meyers
ABSENT:	Mary Holtz



22. RESOLUTION 2014-549

Unsafe-Unsecured/213 Maryvale Drive

Sponsored By: Councilmember Benczkowski, Councilmember Kaminski

WHEREAS, Town of Cheektowaga Law for the Administration and Enforcement of the Codes of New York State; and the Property Maintenance Code of New York State require that all vacant structures and premises shall be maintained in clean, safe, secure and sanitary conditions so as not to cause a blighting problem or adversely affect the public health or safety and all nuisances abated, AND

WHEREAS, the Town of Cheektowaga has received notification of an unsafe structure and premises located at 213 Maryvale Drive, Cheektowaga, New York SBL# 91.09-6-14 that is a danger to the safety of others, and records kept by the Assessors Office identify Wendy S. Wheeler, 213 Maryvale Drive, Cheektowaga, New York 14225, as the owner AND

WHEREAS, an inspection of such premises was conducted at 213 Maryvale Drive, by the Housing and Neighborhood Preservation Office, AND

WHEREAS, such inspection found the premises to be deteriorated, vacant, a hazard, and a danger to the safety and well being of others, AND

WHEREAS, the Town of Cheektowaga Housing and Neighborhood Preservation Office properly notified the property owner in accordance with the Town of Cheektowaga Law for the Administration and Enforcement of the Codes of New York State, and the owner failed to take actions to safeguard the premises, AND

WHEREAS, these conditions require the Town of Cheektowaga Housing and Neighborhood Preservation Office to take immediate steps to safeguard the premises to protect the health and safety of others and abate all nuisances, NOW, THEREFORE BE IT

RESOLVED, that pursuant to Section 70-7A.(5) and Section 70-8 of the Town of Cheektowaga Law for the Administration and Enforcement of the Codes of New York State that the vacant structure premises be safeguarded and all nuisances abated; and all costs incurred be assessed against the property hereinbefore described.

RESULT:	ADOPTED [UNANIMOUS]
MOVER:	Diane Benczkowski, Councilmember
SECONDER:	Gerald Kaminski, Councilmember
AYES:	Rogowski, Kaminski, Wozniak, Benczkowski, Meyers
ABSENT:	Mary Holtz



23. RESOLUTION 2014-550

Unsafe Stagnant Pool and Fence/213 Maryvale Drive

Sponsored By: Councilmember Benczkowski, Councilmember Kaminski

WHEREAS, Town of Cheektowaga Law for the Administration and Enforcement of the Codes of New York State; and the Property Maintenance Code of New York State require that all vacant structures and premises shall be maintained in clean, safe, secure and sanitary conditions so as not to cause a blighting problem or adversely affect the public health or safety and all nuisances abated, AND

WHEREAS, the Town of Cheektowaga has received notification of an unsafe structure and premises located at 213 Maryvale Drive, Cheektowaga, New York SBL# 91.09-6-14 that is a danger to the safety of others, and records kept by the Assessors Office identify Wendy S. Wheeler, 213 Maryvale Drive, Cheektowaga, New York 14225, as the owner AND

WHEREAS, an inspection of such premises was conducted at 213 Maryvale Drive, by the Housing and Neighborhood Preservation Office, AND

WHEREAS, such inspection found the premises to be deteriorated, vacant, a hazard, and a danger to the safety and well being of others, AND

WHEREAS, the Town of Cheektowaga Housing and Neighborhood Preservation Office properly notified the property owner in accordance with the Town of Cheektowaga Law for the Administration and Enforcement of the Codes of New York State, and the owner failed to take actions to safeguard the premises, AND

WHEREAS, these conditions require the Town of Cheektowaga Housing and Neighborhood Preservation Office to take immediate steps to safeguard the premises to protect the health and safety of others and abate all nuisances, NOW, THEREFORE BE IT

RESOLVED, that pursuant to Section 70-7A.(5) and Section 70-8 of the Town of Cheektowaga Law for the Administration and Enforcement of the Codes of New York State that the vacant structure premises be safeguarded and all nuisances abated; and all costs incurred be assessed against the property hereinbefore described.

RESULT:	ADOPTED [UNANIMOUS]
MOVER:	Diane Benczkowski, Councilmember
SECONDER:	Gerald Kaminski, Councilmember
AYES:	Rogowski, Kaminski, Wozniak, Benczkowski, Meyers
ABSENT:	Mary Holtz



24. RESOLUTION 2014-551

Unsafe-Unsecured Debris/54 Reo Avenue

Sponsored By: Councilmember Benczkowski, Councilmember Kaminski

WHEREAS, Town of Cheektowaga Law for the Administration and Enforcement of the Codes of New York State; and the Property Maintenance Code of New York State require that all vacant structures and premises shall be maintained in clean, safe, secure and sanitary conditions so as not to cause a blighting problem or adversely affect the public health or safety and all nuisances abated, AND

WHEREAS, the Town of Cheektowaga has received notification of an unsafe structure and premises located at 54 Reo Avenue, Cheektowaga, New York SBL# 102.53-4-4 that is a danger to the safety of others, and records kept by the Assessors Office identify RVP Development, Inc., 3375 South Park Avenue, Lackawanna, New York 14219, as the owner AND

WHEREAS, an inspection of such premises was conducted at 54 Reo Avenue, by the Housing and Neighborhood Preservation Office, AND

WHEREAS, such inspection found the premises to be deteriorated, vacant, a hazard, and a danger to the safety and well being of others, AND

WHEREAS, the Town of Cheektowaga Housing and Neighborhood Preservation Office properly notified the property owner in accordance with the Town of Cheektowaga Law for the Administration and Enforcement of the Codes of New York State, and the owner failed to take actions to safeguard the premises, AND

WHEREAS, these conditions require the Town of Cheektowaga Housing and Neighborhood Preservation Office to take immediate steps to safeguard the premises to protect the health and safety of others and abate all nuisances, NOW, THEREFORE BE IT

RESOLVED, that pursuant to Section 70-7A.(5) and Section 70-8 of the Town of Cheektowaga Law for the Administration and Enforcement of the Codes of New York State that the vacant structure premises be safeguarded and all nuisances abated; and all costs incurred be assessed against the property hereinbefore described.

RESULT:	ADOPTED [UNANIMOUS]
MOVER:	Diane Benczkowski, Councilmember
SECONDER:	Gerald Kaminski, Councilmember
AYES:	Rogowski, Kaminski, Wozniak, Benczkowski, Meyers
ABSENT:	Mary Holtz



25. RESOLUTION 2014-552

Bonfire-Maryvale School/1050 Maryvale Drive

Sponsored By: Councilmember Benczkowski, Councilmember Kaminski

WHEREAS, pursuant to the Open Burning Law of the Town of Cheektowaga, Joseph Ehnes, Fire Inspector reviews various applications for open fires and open burning and renders his recommendation concerning the fire safety and impact to the general public of such application, AND

WHEREAS, the Town Board, pursuant to the Open Burning Law of the Town of Cheektowaga, is designated the Approval Agency, AND

WHEREAS, since the Town Board is the Approval Agency, it must affirm, modify or reject any recommendations or permits submitted to it by Joseph Ehnes the Town Fire Inspector, AND

WHEREAS, an application for a permit was submitted by the Maryvale High School to conduct an open fire on October 8, 2014 on the property located at 1050 Maryvale Drive, Cheektowaga, New York AND

WHEREAS, the applicant intends to maintain a small bonfire with the assistance of the U-Crest Fire Department in conjunction with summer youth activities, AND

WHEREAS, Joseph Ehnes, Fire Inspector has received this application and finds that all requirements have been met. And that this application is in compliance with conditions and requirement of the Town of Cheektowaga Fire Prevention Code and the Open Burning Law. He requests the Town Board approve issuance of a permit, AND

WHEREAS, this Town Board has reviewed the application submitted by the Maryvale High School and the recommendations of Joseph Ehnes, Fire Inspector, NOW, THEREFORE, BE IT

RESOLVED, that this Town Board, authorizes Joseph Ehnes, Fire Inspector to issue such permit.

RESULT:	ADOPTED [UNANIMOUS]
MOVER:	Diane Benczkowski, Councilmember
SECONDER:	Gerald Kaminski, Councilmember
AYES:	Rogowski, Kaminski, Wozniak, Benczkowski, Meyers
ABSENT:	Mary Holtz



26. RESOLUTION 2014-553

Youth & Recreation Termination

Sponsored By: Councilmember Wozniak, Councilmember Rogowski

BE IT RESOLVED that the individuals listed below be and herby are terminated in the Department of Youth & Recreational Services effective as indicated:

Caitlyn Ferber	Never worked	14225
Jordan Jones	Never worked	14211
Nicole Scherrer	5/23/14	14225

Motion by Councilmember Rogowski; Seconded by Councilmember Meyers to waive the reading of names for the following three (3) resolutions: 2014-553; 2014-554 and 2014-555. Motion Carried.

RESULT: ADOPTED [UNANIMOUS]
MOVER: Angela M. Wozniak, Councilmember
SECONDER: James P. Rogowski, Councilmember
AYES: Rogowski, Kaminski, Wozniak, Benczkowski, Meyers
ABSENT: Mary Holtz



27. RESOLUTION 2014-554

Youth & Recreation Hiring/Transfers

Sponsored By: Councilmember Wozniak, Councilmember Rogowski

BE IT RESOLVED that the individuals listed below be and hereby are hired in the Department of Youth & Recreational Services effective as indicated:

Recreation Attendant - \$9.00 - 7140.1664 - Regular Part-time - Retro to 9/8/14

Melissa Pawlak 14043

Recreation Aide - \$8.00 - 7140.1630 - Part-time

Kellie Kaminski 14043

BE IT FURTHER RESOLVED that the individuals listed below be and hereby are transferred in the Department of Youth & Recreational Services effective as indicated:

Recreation Attendant - Seasonal to Recreation Attendant - Regular Part-time - 7310.1801 & 7310.1803 - \$8.00

Alexandria Makowski
Melissa Owczarzak

Recreation Attendant - Seasonal to Recreation Attendant - Regular Part-time - 7310.1801 & 7310.1803 - \$8.15

Kelly Mayer

Recreation Attendant - Seasonal to Recreation Attendant - Regular Part-time - 7310.1801 & 7310.1803 - \$8.75

Meggan Empric

RESULT:	ADOPTED [UNANIMOUS]
MOVER:	Angela M. Wozniak, Councilmember
SECONDER:	James P. Rogowski, Councilmember
AYES:	Rogowski, Kaminski, Wozniak, Benczkowski, Meyers
ABSENT:	Mary Holtz



28. RESOLUTION 2014-555

Hiring/Termination of Part Time/Seasonal Employees

Sponsored By: Councilmember Kaminski, Councilmember Rogowski

BE IT RESOLVED, that the following individuals be and hereby are hired as **SEASONAL EMPLOYEES**, not to exceed five (5) months in a calendar year, in the various departments listed and in compliance with Civil Service Laws and Regulations as well as the provisions of the Town's collective bargaining agreement between the Town of Cheektowaga and the Town of Cheektowaga Employees Association:

SANITATION DEPARTMENT Laborer \$9.25/hour effective 9/22/14

Derek R. Dalka, Cheektowaga, New York
Michael E. Rara, Jr., Cheektowaga, New York
Trevor D. Starzynski, Cheektowaga, New York

BE IT RESOLVED, that the following individuals be and hereby are hired as **PART-TIME EMPLOYEES** in the departments listed, not to exceed nineteen (19) hours on a weekly basis, in compliance with Civil Service Laws and Regulations as well as the provisions of the Town's collective bargaining agreement between the Town of Cheektowaga and the Town of Cheektowaga Employees Association:

OFFICE OF THE TOWN ASSESSOR Clerk \$9.00/hour effective 10/7/14

Annette K. Rogers, Cheektowaga, New York
Alexandra M. Wachowski, Cheektowaga, New York

BE IT RESOLVED, that the following seasonal and/or part-time employees be and hereby are terminated as listed:

SENIOR SERVICES

John D. Stiegler effective 9/12/14
Cheryl L. McGee effective 8/31/14

POLICE DEPARTMENT

Douglas R. Wilkowski effective 9/23/14
Jennifer A. Martin effective 9/4/14

BE IT RESOLVED, that the following individual's termination date be amended as follows:

FACILITIES DEPARTMENT

Mark R. Aguglia effective 4/22/14

BE IT RESOLVED, that the following transfer take place:

RECORDS MANAGEMENT Clerk (Part Time) to JUSTICE COURT Clerk (Part Time)

\$9.00/hour effective 10/7/14
Maria A. Ross, Cheektowaga, New York

RESULT:	ADOPTED [UNANIMOUS]
MOVER:	Gerald Kaminski, Councilmember
SECONDER:	James P. Rogowski, Councilmember
AYES:	Rogowski, Kaminski, Wozniak, Benczkowski, Meyers
ABSENT:	Mary Holtz



29. RESOLUTION 2014-556

Appointment of Zoning Board Member

Sponsored By: Councilmember Benczkowski, Councilmember Rogowski

WHEREAS, there is a vacancy in the position of member of the Zoning Board of Appeals, and

WHEREAS, Kenneth L. Young has applied for said position and meets the qualifications for said position, NOW, THEREFORE, BE IT

RESOLVED, that Kenneth L. Young of Cheektowaga, New York be and hereby is appointed to the position of Member of the Zoning Board of Appeals, effective immediately and terminating on December 31, 2016.

RESULT:	ADOPTED [UNANIMOUS]
MOVER:	Diane Benczkowski, Councilmember
SECONDER:	James P. Rogowski, Councilmember
AYES:	Rogowski, Kaminski, Wozniak, Benczkowski, Meyers
ABSENT:	Mary Holtz



30. RESOLUTION 2014-557

Travel Authorization Police Department/Police Chief David Zack, Captain Michael Isbrandt, Lieutenant Dana Cadwallader and Sergeant Lawrence Bauer

Sponsored By: Councilmember Benczkowski, Councilmember Kaminski

WHEREAS, the 2014 International Association of Chiefs of Police Conference and Law Enforcement Education and Technology Exposition is being held October 23 through October 28, 2014 in Orlando, Florida; AND

WHEREAS, Police Chief David Zack, Captain Michael Isbrandt, Lieutenant Dana Cadwallader and Sergeant Lawrence Bauer have requested to attend said conference and exposition; AND

WHEREAS, Police Chief David Zack has submitted a request for travel authorization along with the proper paperwork in a timely manner; AND

WHEREAS, the total cost to the Town shall not exceed \$7,746.50; AND

WHEREAS, these expenses have been budgeted by the Department; NOW, THEREFORE, BE IT

RESOLVED, that Police Chief David Zack, Captain Michael Isbrandt, Lieutenant Dana Cadwallader and Sergeant Lawrence Bauer be and hereby are authorized to attend the 2014 International Association of Chiefs of Police Conference and Law Enforcement Education and Technology Exposition being held October 23 through October 28, 2014 in Orlando, Florida.

RESULT:	ADOPTED [UNANIMOUS]
MOVER:	Diane Benczkowski, Councilmember
SECONDER:	Gerald Kaminski, Councilmember
AYES:	Rogowski, Kaminski, Wozniak, Benczkowski, Meyers
ABSENT:	Mary Holtz



31. RESOLUTION 2014-558

Travel Authorization Youth and Recreational Services/Program Coordinator (Youth) Jillian Gorman-King

Sponsored By: Councilmember Kaminski, Councilmember Rogowski

WHEREAS, the Association of New York State Youth Bureaus 44th Annual Youth Development Training Conference is being held October 28 through October 29, 2014 in Liverpool, New York; AND

WHEREAS, Program Coordinator (Youth) Jillian Gorman-King has been recommended to attend said conference; AND

WHEREAS, Executive Director Ellen Fischer has submitted a request for travel authorization along with the proper paperwork in a timely manner; AND

WHEREAS, the total cost to the Town shall not exceed \$75; AND

WHEREAS, these expenses have been budgeted by the Department; NOW, THEREFORE, BE IT

RESOLVED, that Program Coordinator (Youth) Jillian Gorman-King be and hereby is authorized to attend the Association of New York State Youth Bureaus 44th Annual Youth Development Training Conference being held October 28 through October 29, 2014 in Liverpool, New York.

RESULT:	ADOPTED [UNANIMOUS]
MOVER:	Gerald Kaminski, Councilmember
SECONDER:	James P. Rogowski, Councilmember
AYES:	Rogowski, Kaminski, Wozniak, Benczkowski, Meyers
ABSENT:	Mary Holtz

V. Communications

A. Departmental Communications

1. Supervisor's Statement of Funds - August 2014
2. Town of Cheektowaga 2015 Tentative Budget
3. Town of Cheektowaga 2015 Tentative Benefit Basis Budget - September 15, 2014

4. **Minutes: Cheektowaga Conservation Advisory Council - August 7, 2014**
5. **Minutes: Cheektowaga Conservation Advisory Council - September 4, 2014**
6. **Minutes: Cheektowaga Planning Board - September 11, 2014**

B. General Communications

1. **Supplemental Summons: HSBC Bank, USA, NA vs. Heirs at Large of David A. Holdsworth, Deceased & Town of Cheektowaga & Etal Mortgaged Premises: 621 Mt. Vernon Rd.**
2. **Summons & Complaint: Justin Berner vs. Town of Cheektowaga**
3. **Notice of Claim: Sheila Galuszka vs. Town of Cheektowaga**
4. **Notice of Claim: Margaret Lawrie vs. Town of Cheektowaga**
5. **Notice of Claim: Marlene Ponosny vs. Town of Cheektowaga**
6. **Notice of Claim: Julie Thurnherr for Hailey Thurnherr vs. Town of Cheektowaga**

VI. Comments

A. Supervisor's Comments

B. Councilmember's Comments

C. Public Comments

VII. Adjournment

Motion by Councilmember Kaminski; Seconded by Councilmember Rogowski to adjourn the meeting at 7:38 pm

Alice Magierski, Town Clerk

LANDS PROPOSED TO BE INCLUDED IN THE
PINE HILL FIRE DISTRICT

May 15, 2014

ALL THAT TRACT OR PARCEL OF LAND situate in the Town of Cheektowaga, County of Erie, State of New York being part of Lots 25, 26 34 and 35, Township 11, Range 7 of the Holland Land Company's survey, more particularly bounded and described as follows:

BEGINNING at a point at the centerline intersection of Pine Ridge Road and Sugar Road;

THENCE easterly along the northerly boundary line of lands now or formerly of Mount Calvary Cemetery lands, a distance of 1450 feet, more or less, to the centerline of Harlem Road;

THENCE southerly along the centerline of Harlem Road, 187 feet, more or less, to the northwest corner of lands of HR Development Group, LLC.;

THENCE easterly along a line being the southerly line of lands conveyed to 3095 Harlem Road, Inc., as recorded in the Erie County Clerk's Office in Liber 10929 of deeds at page 2998, a distance of 236.73 feet, more or less, to a point;

THENCE northeasterly along a line at an exterior angle of 135°00'00" with the last described course, a distance of 178.52 feet (record) to a point;

THENCE southeasterly at right angles, a distance of 38.00 feet (record) to a point;

THENCE northeasterly at right angles, a distance of 24.00 feet (record) to a point;

THENCE southeasterly at right angles, a distance of 20.00 feet (record) to a point;

THENCE northeasterly at right angles, a distance of 62.00 feet (record) to a point;

THENCE southeasterly at right angles, a distance of 324.00 feet (record) to a point;

THENCE southwesterly at right angles, a distance of 169.64 feet

(record) to a point;

THENCE southeasterly at right angles, a distance of 71.00 feet (record) to a point;

THENCE southwesterly at right angles, a distance of 37.89 feet (record) to a point;

THENCE southeasterly along a line at an exterior angle of 129°30'50" with the last described course, a distance of 43.83 feet (record) to a point;

THENCE southwesterly at right angles, a distance of 22.42 feet (record) to a point;

THENCE southeasterly along a line at an exterior angle of 90°01'55" with the last described course, a distance of 90.87 feet (record) to a point;

THENCE southeasterly along a line at an exterior angle of 163°27'36" with the last described course, a distance of 97.15 feet (record) to a point;

THENCE southerly along a line at an exterior angle of 201°47'27" with the last described course, a distance of 95.11 feet (record) to a point on the northerly line of lands of the Holy Sepulchre Cemetery as recorded in the Erie County Clerk's Office in Liber 1281 of deeds at page 19;

THENCE easterly along the northerly line of said Holy Sepulchre Cemetery, a distance of 2614.4 feet, more or less, to the northeast corner of said Holy Sepulchre Cemetery;

THENCE southerly along the easterly line of lands of said Holy Sepulchre Cemetery and the easterly line of lands of the Diocese of Buffalo as recorded in the Erie County Clerk's Office in Liber 9276 of deeds at page 244, a distance of 558.60 feet (record), more or less, to the southeast corner of the lands of said Diocese of Buffalo and also to a point on the north line of Map Cover 1266;

THENCE westerly along the northerly line of Map Cover 1266, a distance of 1167 feet, more or less, to the northwest corner of said Map Cover 1266;

THENCE southerly along the west line of said Map Cover 1266, a distance of 558.36 feet (record) to a point in the northerly line of Lot 25, said point also being on the northerly line of Map Cover 1317;

THENCE westerly along the north line of said Map Cover 1317 and also being the north line of Lot 25, a distance of 526 feet, more or less to the northwest corner of said Map Cover 1317;

THENCE southerly along the west line of said Map Cover 1317, a distance of 315.35 feet (record), to a point in the centerline of Genesee Street;

THENCE southwesterly along the centerline of Genesee Street, a distance of 4,300 feet more or less, to the centerline intersection point of Pine Ridge Road and Genesee Street;

THENCE northeasterly along the centerline of Pine Ridge Road, a distance of 3750 feet, more or less, to the point or place of beginning.

DESCRIPTION OF PROPOSED PINE HILL
FIRE DISTRICT NO. 5 WITH ADDITIONAL LANDS

MAY 15, 2014

ALL THAT TRACT OR PARCEL OF LAND situate in the Town of Cheektowaga, County of Erie, State of New York being part of Lots 25, 26 34 and 35, Township 11, Range 7 of the Holland Land Company's survey, more particularly bounded and described as follows:

BEGINNING at a point on the westerly line of the Town of Cheektowaga at its intersection with the extension of the centerline of Sugar Road;

THENCE easterly along the centerline of Sugar Road, 2,570 feet, more or less, to the centerline intersection of Pine Ridge Road and Sugar Road;

THENCE easterly along the northerly boundary line of lands now or formerly of Mount Calvary Cemetery, a distance of 1450 feet, more or less, to the centerline of Harlem Road;

THENCE southerly along the centerline of Harlem Road, 187 feet, more or less, to the northwest corner of lands of HR Development Group, LLC.;

THENCE easterly along a line being the southerly line of lands conveyed to 3095 Harlem Road, Inc., as recorded in the Erie County Clerk's Office in Liber 10929 of deeds at page 2998, a distance of 236.7 feet, more or less, to a point;

THENCE northeasterly along a line at an exterior angle of 135°00'00" with the last described course, a distance of 178.52 feet (record) to a point;

THENCE southeasterly at right angles, a distance of 38.00 feet (record) to a point;

THENCE northeasterly at right angles, a distance of 24.00 feet (record) to a point;

THENCE southeasterly at right angles, a distance of 20.00 feet (record) to a point;

THENCE northeasterly at right angles, a distance of 62.00 feet (record) to a point;

THENCE southeasterly at right angles, a distance of 324.00 feet (record) to a point;

THENCE southwesterly at right angles, a distance of 169.64 feet (record) to a point;

THENCE southeasterly at right angles, a distance of 71.00 feet (record) to a point;

THENCE southwesterly at right angles, a distance of 37.89 feet (record) to a point;

THENCE southeasterly along a line at an exterior angle of 129°30'50" with the last described course, a distance of 43.83 feet (record) to a point;

THENCE southwesterly at right angles, a distance of 22.42 feet (record) to a point;

THENCE southeasterly along a line at an exterior angle of 90°01'55" with the last described course, a distance of 90.87 feet (record) to a point;

THENCE southeasterly along a line at an exterior angle of 163°27'36" with the last described course, a distance of 97.15 feet (record) to a point;

THENCE southerly along a line at an exterior angle of 201°47'27" with the last described course, a distance of 95.11 feet (record) to a point on the northerly line of lands of the Holy Sepulchre Cemetery as recorded in the Erie County Clerk's Office in Liber 1281 of deeds at page 19;

THENCE easterly along the northerly line of said Holy Sepulchre Cemetery, a distance of 2614.4 feet, more or less, to the northeast corner of said Holy Sepulchre Cemetery;

THENCE southerly along the easterly line of lands of said Holy Sepulchre Cemetery and the easterly line of lands of the Diocese of Buffalo as recorded in the Erie County Clerk's Office in Liber 9276 of deeds at page 244, a distance of 558.60 feet (record), more or less, to the southeast corner of the lands of said Diocese of Buffalo and also to a point on the north line of Map Cover 1266;

THENCE westerly along the northerly line of Map Cover 1266, a distance of 1167 feet, more or less, to the northwest corner of said Map Cover 1266;

THENCE southerly along the west line of said Map Cover 1266, a distance of 558.36 feet (record) to a point on the northerly line of Lot 25, said point also being on the northerly line of Map Cover 1317;

THENCE westerly along the north line of said Map Cover 1317 and also being the north line of Lot 25, a distance of 526 feet, more or less to the northwest corner of said Map Cover 1317;

THENCE southerly along the west line of said Map Cover 1317, a distance of 315.35 feet (record), to a point in the centerline of Genesee Street;

THENCE southwesterly along the centerline of Genesee Street, to the point of intersection with a line being parallel with the centerline of Harlem Road and distant 500 feet easterly therefrom;

THENCE southerly along said line being parallel with Harlem Road and distant 500 feet easterly therefrom, to the northerly line of lands designated on Page, or Plate, 14 of the New Century Atlas of Erie County, New York, under date of 1909, as "Rochester Land Co. 44A";

THENCE easterly along the northerly bounds of said Rochester Land Co.'s tract, to the easterly bounds thereof;

THENCE southerly along the easterly bounds of said Rochester land Co.'s tract to the point of intersection with the extension of the southerly line of Farm Lot No. 34;

THENCE westerly along said extension of the southerly line of Lot No. 34 and along said southerly line of Lot No. 34 to the point of intersection with the westerly line of the Town of Cheektowaga;

THENCE northerly along said westerly line of the Town of Cheektowaga to the point or place of beginning.

LANDS PROPOSED TO BE INCLUDED IN THE
CLEVELAND HILL FIRE DISTRICT

May 15, 2014

ALL THAT TRACT OR PARCEL OF LAND situate in the Town of Cheektowaga, County of Erie, State of New York being part of Lots 35 and 36, Township 11, Range 7 of the Holland Land Company's survey, more particularly bounded and described as follows:

BEGINNING at a point at the centerline intersection of Pine Ridge Road and Sugar Road;

THENCE northerly along the centerline of Pine Ridge Road and continuing northerly along the centerline extension of said Pine Ridge Road, a distance of 1280 feet, more or less, to the southerly line of lands now or formerly designated as G. F. Rooke as designated and marked on Plate, or Page 14 on the 1909 New Century Atlas of Erie County;

THENCE westerly along the southerly line of lands designated in said Atlas on said Page as G. F. Rooke, 830 feet, more or less to the southeasterly corner of lands so designated in said Atlas on said Page as W. Hayes;

THENCE northerly along the easterly boundary of lands so designated in said Atlas on said Page as W. Hayes and continuing northerly along the easterly line of lands designated in said Atlas on said Page as Land Co. a total distance of 2500 feet, more or less, to a point in the south line of Map Cover 1695;

THENCE easterly, 227.90 feet, more or less along the south line of Map Cover 1695, to the southeast corner of Map Cover 1695;

THENCE northerly, 109 feet, more or less, along the east line of Map Cover 1695 to the south line of Map cover 1726 and also the south line of lands now or formerly owned by one Knoche as designated in said Atlas on said Page as W. Knoche 55 1-2A;

THENCE easterly along the southerly line of said lands of Knoche, and Map Cover 1726, 1822 feet, more or less to the centerline of Harlem Road;

Thence southerly along the centerline of Harlem Road, 3032 feet

more or less, to the centerline of Maryvale drive;

Thence easterly along the centerline of Maryvale Drive to the east line of Harlem Road;

Thence southerly along the easterly line of Harlem Road, 1018.7 feet, more or less, to the northwest corner of lands now or formerly of 3095 Harlem Road, Inc.

THENCE easterly along the northerly line of said lands of 3095 Harlem Road, Inc., 1000 feet (record) to the northeasterly corner of said lands now or formerly of MRP Development Group, LLC.;

THENCE southerly parallel with the easterly line of Harlem Road and along the easterly line of said lands of MRP Development Group, LLC., 876.48 feet (record) to the southeasterly corner thereof and at a point on the northerly line of lands of the Holy Sepulchre Cemetery as recorded in the Erie County Clerk's Office in Liber 1281 of deeds at page 19;

THENCE westerly parallel with the southerly line of Lot 26 and along the northerly line of said lands of the Holy Sepulchre Cemetery, a distance of 401.62 feet (record);

THENCE northerly along a line at an interior angle of $90^{\circ}12'12''$ with the last described course, a distance of 95.11 feet (record) to a point;

THENCE northwesterly along a line at an interior angle of $201^{\circ}47'27''$ with the last described course, a distance of 97.15 feet (record) to a point;

THENCE northwesterly along a line at an interior angle of $163^{\circ}27'36''$ with the last described course, a distance of 90.87 feet (record) to a point;

THENCE northeasterly along a line at an interior angle of $90^{\circ}01'55''$ with the last described course, a distance of 22.42 feet (record) to a point;

THENCE northwesterly at right angles, a distance of 43.83 feet (record) to a point;

THENCE northeasterly along a line at an interior angle of $129^{\circ}30'50''$ with the last described course, a distance of 37.89 feet (record) to a point;

THENCE northwesterly at right angles, a distance of 71.00 feet (record) to a point;

THENCE northeasterly at right angles, a distance of 169.64 feet (record) to a point;

THENCE northwesterly at right angles, a distance of 324.00 feet (record) to a point;

THENCE southwesterly at right angles, a distance of 62.00 feet (record) to a point;

THENCE northwesterly at right angles, a distance of 20.00 feet (record) to a point;

THENCE southwesterly at right angles, a distance of 24.00 feet to (record) a point;

THENCE northwesterly at right angles, a distance of 38.00 feet (record) to a point;

THENCE southwesterly at right angles, a distance of 178.52 feet (record) to a point;

THENCE westerly along a line being the southerly line of lands conveyed to 3095 Harlem Road, Inc., as recorded in the Erie County Clerk's Office in Liber 10929 of deeds at page 2998 and the easterly extension thereof, at an interior angle of 135°00'00", a distance of 236.73 feet, more or less, to a point in the centerline of Harlem Road;

THENCE northerly along said centerline of Harlem Road, a distance of 187 feet, more or less, to the northeast corner of lands now or formerly of Mount Calvary Cemetery;

THENCE westerly along a the northerly boundary line of said Mount Calvary Cemetery lands, a distance of 1450 feet, more or less, to the point or place of beginning.

DESCRIPTION OF PROPOSED CLEVELAND HILL FIRE
DISTRICT NO. 6 WITH ADDITIONAL LANDS

MAY 15, 2014

ALL THAT TRACT OR PARCEL OF LAND situate in the Town of Cheektowaga, County of Erie, State of New York being part of Lots 14, 18, 19, 26, 27, 35, 36 and 37, Township 11, Range 7 of the Holland Land Company's survey, here particularly bounded and described as follows:

BEGINNING at the northwesterly corner of the Town of Cheektowaga;

THENCE easterly along the northerly line of the Town of Cheektowaga 15,227 feet, more or less;

THENCE southerly parallel with Cayuga Road 495 feet (record dimension);

THENCE westerly parallel with the northerly line of the Town of Cheektowaga 660 feet (record) to a point in the centerline of Cayuga Road;

THENCE southerly along the centerline of Cayuga Road 1581.80 feet (record) to a point in the northerly line of lands now or formerly of The Niagara Frontier Transportation Authority;

THENCE easterly at right angles to Cayuga Road and along said northerly line of lands of The Niagara Frontier Transportation Authority, 1300.42 feet (record) to a point in the easterly line of Lot 14;

THENCE southerly along the easterly line of Lot 14, 730.11 feet (record) to a point in the southerly line of lands of The Niagara Frontier Transportation Authority;

THENCE westerly parallel with the southerly line of Lot 14 and along the southerly line of lands of The Niagara Frontier Transportation Authority, 1291.94 feet (record) to a point in the centerline of Cayuga Road;

THENCE southerly along the centerline of Cayuga Road 150 feet (record) to a point in the northerly line of the lands now or formerly of The People of The State Of New York;

THENCE easterly parallel with the southerly line of Lot 14 and along the northerly line of lands of The People Of The State Of New York, 1290 feet, more or less (record), to the easterly line of Lot 14;

C:\users\nmcnally\appdata\local\temp\minutetraq\cheektowagatownny@cheektowagatownny.iqm2.com\work\attachments\2314.doc

THENCE southerly along the easterly line of Lot 14, 1518 feet (record) to a point in the southerly line of lands of The Niagara Frontier Transportation Authority, being also the southeasterly corner of Lot 14;

THENCE westerly along the southerly line of lands of The Niagara Frontier Transportation Authority, and along the southerly line of Lot 14, 1271.25 feet (record) to a point in the centerline of Cayuga Road;

THENCE northerly along the centerline of Cayuga Road 1175.49 (record) to a point in the southerly line of Map Cover 1628 known as Nob Hill Subdivision;

THENCE westerly along the southerly line of Nob Hill Subdivision, 2634.70 feet, (record) to a point in the centerline of Union Road;

THENCE southerly along the centerline of Union Road 400 feet, more or less;

THENCE westerly along the southerly line of Map Covers 1647, 1648, 1649 and 1653 known as Wingdale Subdivision Section One, Parts A, B, C and D and along the southerly line of lands conveyed under Liber 2930 of Deeds, Page 450, 1706.40 feet (record), more or less, to a point distant 300 feet east of the centerline of Beach Road;

THENCE southerly parallel with the centerline of Beach Road, and 300 feet distant easterly therefrom, measured at right angles thereto, 739 feet, more or less to the southerly line of Lot 19;

THENCE westerly along the southerly line of Lot 19, 300 feet to the centerline of Beach Road;

THENCE southerly along the centerline of Beach Road 1450 feet, more or less, to the centerline of Maryvale Drive;

THENCE westerly along the centerline of Maryvale Drive, 1900 feet, more or less, to the westerly line of lands now or formerly of Niagara Mohawk Power Corporation;

THENCE southerly along the westerly line of lands of Niagara Mohawk Power Corporation, 2423.64 feet (record) to the northeasterly corner of Subdivision Map Cover 1266;

THENCE westerly along the northerly line of lands of Map Cover 1266 a distance of 752.27 feet, more or less, to the southeast corner of the lands of the Diocese of Buffalo as recorded in the Erie County Clerk's Office in Liber 9276 of

deeds at page 244;

THENCE northerly along the easterly line of the lands of said Diocese of Buffalo and the lands of Holy Sepulchre Cemetery as recorded in the Erie County Clerk's Office in Liber 1281 of deeds at page 19, a distance of 558.6 feet, more or less, to the northeast corner of lands of said Holy Sepulchre Cemetery;

THENCE westerly along the northerly line of the lands of said Holy Sepulchre Cemetery, a distance of 2614.4 feet, more or less, to a point;

THENCE northerly along a line at an interior angle of $90^{\circ}12'12''$ with the last described course, a distance of 95.11 feet (record) to a point;

THENCE northwesterly along a line at an interior angle of $201^{\circ}47'27''$ with the last described course, a distance of 97.15 feet (record) to a point;

THENCE northwesterly along a line at an interior angle of $163^{\circ}27'36''$ with the last described course, a distance of 90.87 feet (record) to a point;

THENCE northeasterly along a line at an interior angle of $90^{\circ}01'55''$ with the last described course, a distance of 22.42 feet (record) to a point;

THENCE northwesterly at right angles, a distance of 43.83 feet (record) to a point;

THENCE northeasterly along a line at an interior angle of $129^{\circ}30'50''$ with the last described course, a distance of 37.89 feet (record) to a point;

THENCE northwesterly at right angles, a distance of 71.00 feet (record) to a point;

THENCE northeasterly at right angles, a distance of 169.64 feet (record) to a point;

THENCE northwesterly at right angles, a distance of 324.00 feet (record) to a point;

THENCE southwesterly at right angles, a distance of 62.00 feet (record) to a point;

THENCE northwesterly at right angles, a distance of 20.00 feet (record) to a point;

THENCE southwesterly at right angles, a distance of 24.00 feet (record) to a point;

THENCE northwesterly at right angles, a distance of 38.00 feet (record) to a point;

THENCE southwesterly at right angles, a distance of 178.52 feet (record) to

a point;

THENCE westerly along a line being the southerly line of lands conveyed to 3095 Harlem Road, Inc., as recorded in the Erie County Clerk's Office in Liber 10929 of deeds at page 2998 and the easterly extension thereof, at an interior angle of $135^{\circ}00'00''$, a distance of 236.7 feet, more or less, to a point in the centerline of Harlem Road;

THENCE northerly along said centerline of Harlem Road, a distance of 187 feet, more or less, to the northeast corner of lands now or formerly of Mount Calvary Cemetery;

THENCE westerly along a the northerly boundary line of said Mount Calvary Cemetery lands, a distance of 1450 feet, more or less, to the centerline intersection of Pine Ridge Road and Sugar Road;

THENCE westerly along the centerline of Sugar Road, 2,570 feet, more or less, to the westerly line of the Town of Cheektowaga;

THENCE northerly along the westerly line of the Town of Cheektowaga, 6,900 feet, more or less, to the northwesterly corner of the Town of Cheektowaga, the place of beginning.



Town of Cheektowaga

Work Session

~ Minutes ~

3301 Broadway
Cheektowaga, NY 14227
<http://www.town.cheektowaga.ny.us>

Alice Magierski
716-686-3400

Tuesday, October 14, 2014

6:00 PM

Council Office

I. Call to Order

6:00 PM Meeting called to order on October 14, 2014 at Council Office, Conference Room, Cheektowaga, NY.

Attendee Name	Organization	Title	Status	Arrived
Mary Holtz	Town of Cheektowaga	Supervisor	Present	
James P. Rogowski	Town of Cheektowaga	Councilmember	Present	
Gerald Kaminski	Town of Cheektowaga	Councilmember	Present	
Angela M. Wozniak	Town of Cheektowaga	Councilmember	Present	
Diane Benczkowski	Town of Cheektowaga	Councilmember	Present	
Timothy J. Meyers	Town of Cheektowaga	Councilmember	Present	

2. Additional Attendees

Brian Krause, Director of Finance and Administration
Karen Marchese, Coordinator of Employee Relations
Kevin Schenk, Town Attorney

II. Enter Into Executive Session

Motion by Supervisor Holtz, seconded by Councilmember Kaminski to enter Into executive session at 6:00 PM. Motion carried

III. Exit Executive Session

Motion by Councilmember Rogowski; Seconded by Councilmember Kaminski to exit Executive Session at 6:07 PM. Motion Carried.

IV. Resolution



1. RESOLUTION 2014-559

Settlement of Litigation - Moores Vs Town

Sponsored By: Councilmember Kaminski, Supervisor Holtz

WHEREAS, on or about November 1, 2007, an action (Joan T. Moores, et al. vs Town of Cheektowaga, et al, Index No. I-2007-10772) was commenced against the Town; and

WHEREAS, the law firm of Chelus, Herdzyk, Speyer & Monte, P.C. (Arthur A. Herdzyk, Esq., of counsel) was retained to represent the Town; vigorously defended the interests of the Town with regard to this claim; and has recommended a settlement with the claimant's attorneys; and

WHEREAS, this settlement is in the best interests of the Town of Cheektowaga;

NOW THEREFORE, BE IT

RESOLVED, that the Town Board approves of the above settlement with the Stipulation of Discontinuance and Settlement Agreement and Release being signed by the plaintiff; and the Supervisor, Town Attorney and/or Chelus, Herdzyk, Speyer & Monte, P.C. be and hereby are authorized to execute and procure all papers necessary to effectuate said settlement and compromise of the above mentioned claim in accordance with the terms of the Settlement Agreement and Release and Stipulation of Discontinuance.

RESULT:	ADOPTED [UNANIMOUS]
MOVER:	Gerald Kaminski, Councilmember
SECONDER:	Mary Holtz, Supervisor
AYES:	Holtz, Rogowski, Kaminski, Wozniak, Benczkowski, Meyers



Town of Cheektowaga

Regular Meeting

~ Minutes ~

3301 Broadway
Cheektowaga, NY 14227
<http://www.town.cheektowaga.ny.us>

Alice Magierski
716-686-3400

Monday, October 20, 2014

6:45 PM

Council Chambers

I. Call to Order

6:45 PM Meeting called to order on October 20, 2014 at Council Chambers, 3301 Broadway St, Cheektowaga, NY.

Attendee Name	Organization	Title	Status	Arrived
Mary Holtz	Town of Cheektowaga	Supervisor	Present	
James P. Rogowski	Town of Cheektowaga	Councilmember	Present	
Gerald Kaminski	Town of Cheektowaga	Councilmember	Present	
Angela M. Wozniak	Town of Cheektowaga	Councilmember	Present	
Diane Benczkowski	Town of Cheektowaga	Councilmember	Present	
Timothy J. Meyers	Town of Cheektowaga	Councilmember	Present	

2. Additional Attendees

Patrick Bowen, Town Engineer
Carla A. Kosmerl, Director of Community Development
Brian Krause, Director of Finance and Administration
Karen R. Marchese, Coordinator of Employee Relations
Kevin Schenk, Town Attorney

II. Public Comment Period

III. Public Hearings

1. Rezoning Request

Part of 2525 and 2535 Walden Avenue

COMMENTS - Current Meeting:

This being the time and place advertised for a Public Hearing, the Supervisor directed the Town Clerk to present that such notice has been duly published and posted; upon the order of the Supervisor such proof was duly filed.

The Supervisor announced that the Town Board would hear all persons interested in the subject of the hearing. Comments were heard, after which the Supervisor declared the hearing closed, decision was reserved.

RESULT: CLOSED [UNANIMOUS]
MOVER: Diane Benczkowski, Councilmember
SECONDER: James P. Rogowski, Councilmember
AYES: Holtz, Rogowski, Kaminski, Wozniak, Benczkowski, Meyers

2. Community Development Funds

COMMENTS - Current Meeting:

This being the time and place advertised for a Public Hearing, the Supervisor directed the Town Clerk to present that such notice has been duly published and posted; upon the order of the Supervisor such proof was duly filed.

The Supervisor announced that the Town Board would hear all persons interested in the subject of the hearing. Comments were heard, after which the Supervisor declared the hearing closed, decision was reserved.

RESULT: CLOSED [UNANIMOUS]
MOVER: Mary Holtz, Supervisor
SECONDER: Diane Benczkowski, Councilmember
AYES: Holtz, Rogowski, Kaminski, Wozniak, Benczkowski, Meyers

3. Extend Pine Hill Fire District No. 5

COMMENTS - Current Meeting:

This being the time and place advertised for a Public Hearing, the Supervisor directed the Town Clerk to present that such notice has been duly published and posted; upon the order of the Supervisor such proof was duly filed.

The Supervisor announced that the Town Board would hear all persons interested in the subject of the hearing. Comments were heard, after which the Supervisor declared the hearing closed, decision was reserved.

RESULT: CLOSED [UNANIMOUS]
MOVER: James P. Rogowski, Councilmember
SECONDER: Timothy J. Meyers, Councilmember
AYES: Holtz, Rogowski, Kaminski, Wozniak, Benczkowski, Meyers

4. Extend Cleveland Hill Fire District No. 6

COMMENTS - Current Meeting:

This being the time and place advertised for a Public Hearing, the Supervisor directed the Town Clerk to present that such notice has been duly published and posted; upon the order of the Supervisor such proof was duly filed.

The Supervisor announced that the Town Board would hear all persons interested in the subject of the hearing. Comments were heard, after which the Supervisor declared the hearing closed, decision was reserved.

RESULT: CLOSED [UNANIMOUS]
MOVER: James P. Rogowski, Councilmember
SECONDER: Timothy J. Meyers, Councilmember
AYES: Holtz, Rogowski, Kaminski, Wozniak, Benczkowski, Meyers

5. Demolition of 36 Barbara Place

COMMENTS - Current Meeting:

This being the time and place advertised for a Public Hearing, the Supervisor directed the Town Clerk to present that such notice has been duly published and posted; upon the order of the Supervisor such proof was duly filed.

The Supervisor announced that the Town Board would hear all persons interested in the subject of the hearing. Comments were heard, after which the Supervisor declared the hearing closed, decision was reserved.

RESULT: CLOSED [UNANIMOUS]
MOVER: Mary Holtz, Supervisor
SECONDER: Diane Benczkowski, Councilmember
AYES: Holtz, Rogowski, Kaminski, Wozniak, Benczkowski, Meyers

6. Demolition of 36 Peachrow Lane

COMMENTS - Current Meeting:

This being the time and place advertised for a Public Hearing, the Supervisor directed the Town Clerk to present that such notice has been duly published and posted; upon the order of the Supervisor such proof was duly filed.

The Supervisor announced that the Town Board would hear all persons interested in the subject of the hearing. Comments were heard, after which the Supervisor declared the hearing closed, decision was reserved.

RESULT: CLOSED [UNANIMOUS]
MOVER: Mary Holtz, Supervisor
SECONDER: Diane Benczkowski, Councilmember
AYES: Holtz, Rogowski, Kaminski, Wozniak, Benczkowski, Meyers

IV. Resolutions



1. RESOLUTION 2014-560

Transfer of Funds

Sponsored By: Councilmember Kaminski, Supervisor Holtz

BE IT RESOLVED, that the following transfer is hereby approved and made part hereof;

CDBG			
FROM:	700.9007.0662	Village of Sloan/Drainage&Sewer Improv	\$20,125.65
	700.9011.0662	Village of Sloan/Drainage&Sewer Improv	15,980.00
	700.1002.0705	Cheektowaga Economic Dev. Activity	1.00
	700.1008.0753	Neighborhood Preservation Activities	1,112.48
	700.1013.0704	Contingency	2,425.00
	700.1014.0679	Summer Day Camp	4,306.25
TO:	700.1014.0600	Housing Rehab-Single Family	\$36,105.65
	700.1014.0600	Housing Rehab-Single Family	7,844.73

RESULT:	ADOPTED [UNANIMOUS]
MOVER:	Gerald Kaminski, Councilmember
SECONDER:	Mary Holtz, Supervisor
AYES:	Holtz, Rogowski, Kaminski, Wozniak, Benczkowski, Meyers



2. RESOLUTION 2014-561

Warrant

Sponsored By: Supervisor Holtz, Councilmember Kaminski

BE IT RESOLVED, that the following Vouchers & Warrants submitted to the Town of Cheektowaga prior to October 20, 2014 are hereby approved and made part hereof;

GENERAL FUND	\$103,563.74
RISK RETENTION FUND	37,669.20
NYS HOME PROGRAM	0.00
DEBT	0.00
HUD HOUSING REHABILITATION FUND	8,700.00
SPECIAL DISTRICTS FUND	347,094.76
HIGHWAY FUND	28,135.15
CAPITAL FUND	281,105.69
TRUST & AGENCY FUND	3,403.86
HUD CDBG FUND	135,507.89
PART TOWN FUND	6,490.47
NYS AFFORDABLE HOUSING	0.00
	<hr/>
	\$951,670.76

RESULT:	ADOPTED [UNANIMOUS]
MOVER:	Mary Holtz, Supervisor
SECONDER:	Gerald Kaminski, Councilmember
AYES:	Holtz, Rogowski, Kaminski, Wozniak, Benczkowski, Meyers



3. RESOLUTION 2014-562

Change Order No. 1 - Reroofing the Senior Citizens Center

Sponsored By: Supervisor Holtz, Councilmember Kaminski

WHEREAS, the contract to reroof the Senior Citizens Center was awarded by Town Board Resolution dated May 19, 2014 to Tschetter's Construction Corporation in the amount of \$148,412.00, AND

WHEREAS, upon removal of the existing shingles, it became evident that the existing plywood was dry rotted and needed to be replaced due to a lack of existing ventilation along with additional metal flashing, AND

WHEREAS, additional precautions were taken to further prevent water and ice buildup, AND

WHEREAS, the Town Engineer has recommended the approval of Change Order No. 1 (final) which provides for various repairs and preventative measures as further outlined on the Change Order Documents, NOW, THEREFORE, BE IT

RESOLVED, that Change Order No. 1 (final) for Reroofing the Senior Citizens Center, in the amount of \$50,667.50 (original budget \$185,000) as an addition to the contract of Tschetter's Construction Corporation, 4560 Clinton Street, West Seneca, New York be and hereby is approved, AND, BE IT FURTHER

RESOLVED, that the Supervisor is hereby authorized to execute said Change Order Documents with Tschetter's Construction Corporation on behalf of this Town Board, AND, BE IT FURTHER

RESOLVED, that said funds for Change Order No. 1 (final) shall be chargeable to Account #500-7620-9508-5329.

RESULT:	ADOPTED [UNANIMOUS]
MOVER:	Mary Holtz, Supervisor
SECONDER:	Gerald Kaminski, Councilmember
AYES:	Holtz, Rogowski, Kaminski, Wozniak, Benczkowski, Meyers



4. RESOLUTION 2014-563

Accept Site Plan- 585 Duke Road Derrick Manufacturing

Sponsored By: Councilmember Benczkowski, Councilmember Rogowski

WHEREAS, pursuant to the Zoning Law of the Town of Cheektowaga, the Planning Board reviews various development review applications for site plans, rezonings, special permits and realty subdivisions and renders its recommendation concerning the compatibility of such application with the zoning regulations, the Town Master Plan and neighborhood character, AND

WHEREAS, the Town Board, pursuant to section 260-47.1C of the Zoning Law of the Town of Cheektowaga is vested with the authority to approve site plans and modify or reject any recommendation submitted to it by its advisory committees, AND

WHEREAS, LBM Construction, Inc. on behalf of Derrick Manufacturing submitted a development review application for a 5,495 s.f. building addition to an existing warehouse /office at 585 Duke Road, AND

WHEREAS, this Town Board on March 21, 2005 previously issued a determination of non-significance pursuant to the State Environmental Quality Review Act (SEQRA) for a 19,865 s.f. warehouse/office building, AND

WHEREAS, the proposed building addition is a second building phase creating a total of 15,815 sf of building area, AND

WHEREAS, the Town of Cheektowaga Planning Board, reviewed and commented on the Application at their meeting of October 9, 2014 and have recommended approval thereof, NOW THEREFORE BE IT,

RESOLVED, that pursuant to Section 260-47-1 of the Code of the Town of Cheektowaga and Section 274-a of New York State Town Law that this Town Board approves the proposed site plan subject to:

1. The Town Engineer reviewing and approving the drainage/grading plan.

RESULT:	ADOPTED [UNANIMOUS]
MOVER:	Diane Benczkowski, Councilmember
SECONDER:	James P. Rogowski, Councilmember
AYES:	Holtz, Rogowski, Kaminski, Wozniak, Benczkowski, Meyers



5. RESOLUTION 2014-564

Accept Site Plan- 1035 Rein Road

Sponsored By: Councilmember Benczkowski, Councilmember Rogowski

WHEREAS, pursuant to the Zoning Law of the Town of Cheektowaga, the Planning Board reviews various development review applications for site plans, rezonings, special permits and realty subdivisions and renders its recommendation concerning the compatibility of such application with the zoning regulations, the Town Master Plan and neighborhood character, AND

WHEREAS, the Town Board, pursuant to section 260-47.1C of the Zoning Law of the Town of Cheektowaga is vested with the authority to approve site plans and modify or reject any recommendation submitted to it by its advisory committees, AND

WHEREAS, Tim Graves of Superior Contracting Submitted a development review application for a 3,150 s.f. building addition to an existing warehouse /office at 1035 Rein Road, AND

WHEREAS, the Town of Cheektowaga Planning Board, reviewed and commented on the Application at their meeting of October 9, 2014 and have recommended approval thereof, NOW THEREFORE BE IT,

RESOLVED, that pursuant to Section 260-47-1 of the Code of the Town of Cheektowaga and Section 274-a of New York State Town Law that this Town Board approves the proposed site plan.

RESULT:	ADOPTED [UNANIMOUS]
MOVER:	Diane Benczkowski, Councilmember
SECONDER:	James P. Rogowski, Councilmember
AYES:	Holtz, Rogowski, Kaminski, Wozniak, Benczkowski, Meyers



6. RESOLUTION 2014-565

Accept Site Plan- 2013 Walden Avenue Panera Bread

Sponsored By: Councilmember Benczkowski, Councilmember Rogowski

WHEREAS, pursuant to the Zoning Law of the Town of Cheektowaga, the Planning Board reviews various development review applications for site plans, rezonings, special permits and realty subdivisions and renders its recommendation concerning the compatibility of such application with the zoning regulations, the Town Master Plan and neighborhood character, AND

WHEREAS, the Town Board, pursuant to section 260-47.1C of the Zoning Law of the Town of Cheektowaga is vested with the authority to approve site plans and modify or reject any recommendation submitted to it by its advisory committees, AND

WHEREAS, Benderson Development Co., LLC. Submitted a development review application for a 2,301 s.f. building addition to an existing restaurant at 2013 Walden Avenue to accommodate two new restaurant tenants, one of which will also have an accessory drive through window, AND

WHEREAS, the Town of Cheektowaga Planning Board, reviewed and commented on the Application at their meeting of August 14, 2014 and have recommended approval thereof, NOW THEREFORE BE IT,

RESOLVED, that pursuant to Section 260-47-1 of the Code of the Town of Cheektowaga and Section 274-a of New York State Town Law that this Town Board approves the proposed site plan.

Attachments:

PROPOSED SITE PLAN 10-14-2014 (PDF)

RESULT:	ADOPTED [UNANIMOUS]
MOVER:	Diane Benczkowski, Councilmember
SECONDER:	James P. Rogowski, Councilmember
AYES:	Holtz, Rogowski, Kaminski, Wozniak, Benczkowski, Meyers



7. RESOLUTION 2014-566

Approve Special Use Permit & Variance - 2013 Walden Avenue

Sponsored By: Councilmember Benczkowski, Councilmember Meyers

WHEREAS, Benderson Development Company, LLC has applied for a Special Use Permit to establish an accessory drive through window for a proposed restaurant/cafe on property owned by Buffalo WVP Associates, LLC and located at 2013 Walden Avenue, Cheektowaga, New York, pursuant to Sections 260-47 and 260-48.2 of the Code of the Town of Cheektowaga ("Zoning Law"); and

WHEREAS, Benderson Development Company, LLC also requested a variance to reduce the number of vehicle queues from sixteen (16) to seven (7), and

WHEREAS, a public hearing was held before the Cheektowaga Town Board on the 15th day of September, 2014 at 6:45 P.M. of said day for the purpose of considering said applications for a Special Permit and variances from the Zoning Law, after publication and service of the notices required by the provisions of the Zoning Law and the Town Law; and all interested parties were given an opportunity to be heard at such hearing; and

WHEREAS, the Cheektowaga Planning Board has recommended approval of this Special Permit and variance; and

WHEREAS, this Town Board previously issued a Negative Declaration under SEQRA for this project; NOW, THEREFORE BE IT

RESOLVED, that the aforesaid Special Use Permit be and hereby is granted, and BE IT FURTHER

RESOLVED, that this Town Board hereby grants the aforementioned variance relating to the reduction in the vehicle queue from sixteen (16) to seven (7).

RESULT:	ADOPTED [UNANIMOUS]
MOVER:	Diane Benczkowski, Councilmember
SECONDER:	Timothy J. Meyers, Councilmember
AYES:	Holtz, Rogowski, Kaminski, Wozniak, Benczkowski, Meyers



8. RESOLUTION 2014-567

Notice to Bidders - Two 2014 Ford Focus S Sedans, or Equal (Bid #2014-33)

Sponsored By: Councilmember Kaminski, Supervisor Holtz

WHEREAS, it is in order that a Notice to Bidders be advertised for the purchase of two (2) new and unused 2014 or newer Ford Focus S, 4-Door Sedans, or equal, for the motor pool (Bid 2014-33), NOW, THEREFORE, BE IT

RESOLVED, that the Town Clerk be and hereby is directed to publish a Notice to Bidders for the purchase of said vehicles for the motor pool, said notice to be published in the CHEEKTOWAGA BEE, AND, BE IT FURTHER

RESOLVED, that sealed bids will be received on the 5th day of November, 2014 at 11:00 am, Local Time, at a public bid opening to be held in the Council Chambers in the Cheektowaga Town Hall.



NOTICE TO BIDDERS

Sealed proposals will be received by the Town of Cheektowaga on November 5, 2014 at 11:00 am, Local Time, at the Town Hall, corner of Broadway and Union Roads, for the purchase of two (2) new and unused 2014 or newer Ford Focus S, 4-Door Sedans, or equal (Bid 2014-33).

Information for bidders and specifications may be obtained from the Town Clerk at her office in Town Hall.

The Town Board reserves the right to consider informal any bid not prepared and submitted in accordance with the provisions of the specifications and contract documents, and may waive any informalities, make an award to other than the low bidder, should it be in the best interest of the Town, or reject any or all bids.

By order of the Town Board of the Town of Cheektowaga, Erie County, New York.

Alice Magierski, Town Clerk

DATED: October 20, 2014

PUBLISHED: October 23, 2014

RESULT: **ADOPTED [UNANIMOUS]**
MOVER: Gerald Kaminski, Councilmember
SECONDER: Mary Holtz, Supervisor
AYES: Holtz, Rogowski, Kaminski, Wozniak, Benczkowski, Meyers



9. RESOLUTION 2014-568

Notice to Bidders - One 2014 or Newer Ford Escape SE, SUV, or Equal (Bid #2014-34)

Sponsored By: Councilmember Meyers, Supervisor Holtz

WHEREAS, it is in order that a Notice to Bidders be advertised for the purchase of one (1) new and unused 2014 or newer Ford Escape SE, SUV, or equal (Bid 2014-34), NOW, THEREFORE, BE IT

RESOLVED, that the Town Clerk be and hereby is directed to publish a Notice to Bidders for the purchase of said vehicle, said notice to be published in the CHEEKTOWAGA BEE, AND, BE IT FURTHER

RESOLVED, that sealed bids will be received on the 5th day of November, 2014 at 11:00 A.M., Local Time, at a public bid opening to be held in the Council Chambers in the Cheektowaga Town Hall.



NOTICE TO BIDDERS

Sealed proposals will be received by the Town of Cheektowaga on November 5, 2014 at 11:00 A.M., Local Time, at the Town Hall, corner of Broadway and Union Roads, for the purchase of one (1) new and unused 2014 or newer Ford Escape SE, SUV, or equal (Bid 2014-34).

Information for bidders and specifications may be obtained from the Town Clerk at her office in Town Hall.

The Town Board reserves the right to consider informal any bid not prepared and submitted in accordance with the provisions of the specifications and contract documents, and may waive any informalities, make an award to other than the low bidder, should it be in the best interest of the Town, or reject any or all bids.

By order of the Town Board of the Town of Cheektowaga, Erie County, New York.

Alice Magierski, Town Clerk

DATED: October 20, 2014

PUBLISH: October 23, 2014

RESULT: **ADOPTED [UNANIMOUS]**
MOVER: Timothy J. Meyers, Councilmember
SECONDER: Mary Holtz, Supervisor
AYES: Holtz, Rogowski, Kaminski, Wozniak, Benczkowski, Meyers



10. RESOLUTION 2014-569

Notice to Bidders - 2015 New and Unused Step Van Truck with an Integrated 16 foot Aluminum Body and Dual Rear Wheels (Bid 2014-35)

Sponsored By: Councilmember Rogowski, Supervisor Holtz

NOTICE IS HEREBY GIVEN, that the Town of Cheektowaga Highway Department will receive bids for the purchase of One (1) New and Unused 2015 Step Van Truck with an integrated 16 foot Aluminum Body and Dual Rear Wheels (Bid 2014-35) for use by the Traffic Maintenance Department in the Town of Cheektowaga at a public bid opening to be held in the Council Chambers at the Cheektowaga Town Hall on November 5, 2014 at 11:00 A.M.

Information for bidders specifications may be obtained from the office of the Town Clerk, Cheektowaga Town Hall, Broadway and Union Roads, Cheektowaga, New York, between the hour of 9:00 am and 4:30 PM, Monday through Friday, NOW THEREFORE BE IT

RESOLVED, that the Town Clerk is hereby designated as the Office to open bids on the aforesaid items at a public bid opening on Wednesday, November 5, 2014, at 11:00 AM, in the Council Chambers of the Cheektowaga Town Hall.



NOTICE TO BIDDERS

Sealed proposals will be received by the Town of Cheektowaga on November 5, 2014 at 11:00 AM at the Town Hall, corner of Broadway and Union Roads, for the One (1) New and Unused 2015 Model Step Van Truck with an Integrated 16 Foot Aluminum Body and Dual Rear Wheels (Bid 2014-35).

Information for bidders and specifications may be obtained from the Town Clerk at her office in said Town.

The Town Board reserves the right to consider informal any bid not prepared and submitted in accordance with the provisions of the specifications and contract documents, and may waive any informalities, make an award to other than the low bidder, should it be in the best interest of the Town, or reject any or all bids.

By order of the Town Board of the Town of Cheektowaga, Erie County, New York.

Alice Magierski, Town Clerk

RESULT:	ADOPTED [UNANIMOUS]
MOVER:	James P. Rogowski, Councilmember
SECONDER:	Mary Holtz, Supervisor
AYES:	Holtz, Rogowski, Kaminski, Wozniak, Benczkowski, Meyers



11. RESOLUTION 2014-570

Authorize Town Clerk to Issue New/Renewal Ambulance Driver/Attendant Licenses

Sponsored By: Supervisor Holtz, Councilmember Kaminski

WHEREAS, on the 7th day of May, 1984, this Town Board adopted an Ambulance Ordinance. The EMS Board, which was created at that time, has completed a review and evaluation of new/renewal license applications for driver(s)/attendant(s), and has recommended that the Town Board issue such licenses, NOW, THEREFORE BE IT

RESOLVED, that the recommendations of the EMS Board concerning the licensing of new/renewal driver(s)/attendant(s) shown on the list below be and hereby are accepted and approved, for a period to expire upon the expiration of such ambulance driver(s)/attendant(s) Emergency Medical Technician ('EMT') card and, BE IT FURTHER

RESOLVED, that the Town Clerk be and hereby is authorized, empowered and directed to issue new/renewal licenses to the driver(s)/attendant(s) set forth on the annexed schedule, pursuant to the terms of this resolution.

Balicki, Brandon	6/30/2015
Bluhm, Garry F	7/31/2017
Bluhm, Sara A	2/28/2017
Buczowski, Craig J	9/30/2017
Carlson, Mitchell	8/31/2016
Catanesi, Raymond	6/30/2017
Clark, Alexander J	6/30/2016
Durlak, Teresa	5/31/2017
Gieseler, Carl J	6/30/2017
Hardy, Jeremy C	9/30/2017
Heary, Jeremy J	8/31/2017
Hinz, Ryan	4/30/2016
Hunter, Rebecca	1/31/2017
Lindstrom, Nicholas	7/31/2017
Mack, Amy C	7/31/2017
Masullo, Laura A	12/31/2017
McMahon, Dillon	1/31/2017
McNamara, Corey J	6/30/2017
Miller, Christina M	6/30/2017
Mondal, Ismahr A	4/30/2017
Murtha, Leigh P	12/31/2016
Noworyta, Mark F	8/31/2017
Ovitt, Kailyn M	7/31/2016
Pipkins, Kearsten	6/30/2017

Pyra, Timothy R	4/30/2017
Robinson, Alexander	2/28/2017
Schneider, Stephen	9/30/2016
Scott, DiAnna P	6/30/2017
Slusser, David H Jr	8/31/2017
Smith, Thomas L	1/31/2017
Strough, Natasha	2/28/2016
Weber, Eric Scott	4/30/2017
Webster, Mark	4/30/2016
Williams, Eugene A.	4/30/2017
Williams, Venecia D	6/30/2017
Xenos, Demetria A	2/28/2017
Zgoda, Jeffrey	6/30/2017

RESULT: ADOPTED [UNANIMOUS]

MOVER: Mary Holtz, Supervisor

SECONDER: Gerald Kaminski, Councilmember

AYES: Holtz, Rogowski, Kaminski, Wozniak, Benczkowski, Meyers



12. RESOLUTION 2014-571

Approve Purchase of Rotary Mower for the Facilities Department

Sponsored By: Councilmember Rogowski, Councilmember Wozniak

WHEREAS, the Director of the Facilities Department is in need of a rotary mower for use in maintaining Town Parks, and

WHEREAS, the purchase of such equipment is available through S.V. Moffett Turf Equipment as per New York State Contract #PC64364, Award #21459, and

WHEREAS, moneys have been appropriated in the Facilities Department budget for the purchase said line 100-7110-2304, and

WHEREAS, Section 103-b of the General Municipal Law authorizes the Town to enter into a purchase agreement for machinery, equipment or apparatus, and

WHEREAS, the proposed Purchase Agreement with S.V. Moffett Turf Equipment contains the language required by Section 103-b of the General Municipal Law and otherwise complies with New York State law, NOW, THEREFORE BE IT

RESOLVED, that this Town Board hereby approves the purchase of one (1) Jacobsen Mower HR-9016 Turbo Wide-Area Rotary Mower for use by the Facilities Department as per the terms of it Municipal Agreement at the cost of \$53,062.11, and BE IT FURTHER

RESOLVED, that the Supervisor, on behalf of the Town, be and hereby is authorized an directed to execute the purchase agreement and all other documents necessary for the purchase of the above referenced equipment, subject, however, to approval by the Town Attorney, and BE IT FURTHER

RESOLVED, that funds for payments shall be appropriated from the Facilities Department budget line 100-7110-2304.

RESULT:	ADOPTED [UNANIMOUS]
MOVER:	James P. Rogowski, Councilmember
SECONDER:	Angela M. Wozniak, Councilmember
AYES:	Holtz, Rogowski, Kaminski, Wozniak, Benczkowski, Meyers



13. RESOLUTION 2014-572

Approve Purchase of T590 T4 Bobcat Track Loader for the Facilities Department

Sponsored By: Councilmember Rogowski, Councilmember Wozniak

WHEREAS, the Director of the Facilities Department is in need of a T590 T4 Bobcat Compact Track Loader for use in maintaining Town Parks, and

WHEREAS, the purchase of such equipment is available through Bobcat of Buffalo, as per New York State Contract #PC66576, Award #22792, and

WHEREAS, moneys have been appropriated in the Facilities Department budget for the purchase said line 100-7110-2304, and

WHEREAS, Section 103-b of the General Municipal Law authorizes the Town to enter into a purchase agreement for machinery, equipment or apparatus, and

WHEREAS, the proposed Purchase Agreement with Bobcat of Buffalo contains the language required by Section 103-b of the General Municipal Law and otherwise complies with New York State law, NOW, THEREFORE BE IT

RESOLVED, that this Town Board hereby approves the purchase of one (1) T590 T4 Bobcat Compact Track Loader for use by the Facilities Department as per the terms of it Municipal Agreement at the cost of \$42,261.30, and BE IT FURTHER

RESOLVED, that the Supervisor, on behalf of the Town, be and hereby is authorized and directed to execute the purchase agreement and all other documents necessary for the purchase of the above referenced equipment, subject, however, to approval by the Town Attorney, and BE IT FURTHER

RESOLVED, that funds for payments shall be appropriated from the Facilities Department budget line 100-7110-2304.

RESULT:	ADOPTED [UNANIMOUS]
MOVER:	James P. Rogowski, Councilmember
SECONDER:	Angela M. Wozniak, Councilmember
AYES:	Holtz, Rogowski, Kaminski, Wozniak, Benczkowski, Meyers



14. RESOLUTION 2014-573

Accept Proposal of Nussbaumer & Clarke, Inc. for Water Service Replacement and Improvements at the Main Pump Station

Sponsored By: Councilmember Meyers, Supervisor Holtz

WHEREAS, the Main Pump Station is in need of upgrades and improvements to its water service and fire protection, and which facility is an integral component of the Town's wastewater collection and conveyance infrastructure, AND

WHEREAS, the existing water services for the Main Pump Station have experienced breaks, incurred temporary repairs and are in need of replacement, AND

WHEREAS, there is a need to prepare an engineering report, detailed drawings and technical specifications for the installation of new water services and improvements to the fire protection system, NOW, THEREFORE, BE IT

RESOLVED, that the proposal of Nussbaumer & Clarke, Inc., dated August 29, 2014 as submitted to the Town Engineer for professional services for the preparation of an engineering report, design plans and technical specifications and related bid documents for water service replacement at the Main Pump Station, Tasks No. 1 through 5, is accepted and approved, AND, BE IT FURTHER

RESOLVED, that the Supervisor, on behalf of this Town Board, is hereby directed and authorized to execute the professional services proposal for Tasks No. 1 through 5 with Nussbaumer & Clarke, Inc. For the provision of said technical services, AND, BE IT FURTHER

RESOLVED, that the cost of said professional services in an amount not to exceed \$22,800.00 shall be chargeable to a Capital Account designated by the Director of Finance.

RESULT:	ADOPTED [UNANIMOUS]
MOVER:	Timothy J. Meyers, Councilmember
SECONDER:	Mary Holtz, Supervisor
AYES:	Holtz, Rogowski, Kaminski, Wozniak, Benczkowski, Meyers



15. RESOLUTION 2014-574

Special Event - South Line Fire Company Halloween Parade

Sponsored By: Councilmember Meyers, Councilmember Rogowski

WHEREAS, South Line Volunteer Fire Company has made application to hold their Annual Halloween Parade on Saturday, October 25, 2014 at 6:30 p.m., beginning from their fire hall to Violet Senior Housing, around the building, and then returning to fire hall; and

WHEREAS, this Board has reviewed the aforementioned application, which application has been approved by the Department of Parks, Recreation & Youth Services and the Police Department, and has no objection to same, and

WHEREAS, due to the nature of the event, this Town Board hereby waives the following requirements:

- . Submittal of plan for sanitary facilities;
- . Submittal of site plan;
- . Submittal of Security Plan;
- . Submittal of Fire Prevention/Emergency Services Plan;

NOW, THEREFORE, BE IT

RESOLVED, that this Town Board hereby approves the aforementioned application of the South Line Volunteer Fire Company for the aforementioned Halloween Parade to be held on Saturday, October 25, 2014 at 6:30 PM, and BE IT FURTHER

RESOLVED, that the Chief of Police be and hereby is directed to provide traffic safety and escort services for such parade and to ensure compliance with Section 1660(a)(6) of the Vehicle and Traffic Law.

RESULT:	ADOPTED [UNANIMOUS]
MOVER:	Timothy J. Meyers, Councilmember
SECONDER:	James P. Rogowski, Councilmember
AYES:	Holtz, Rogowski, Kaminski, Wozniak, Benczkowski, Meyers



16. RESOLUTION 2014-575

Reappointments and Appointments to Cheektowaga Conservation Advisory Committee

Sponsored By: Councilmember Meyers, Supervisor Holtz

WHEREAS, by resolution dated July 2, 1990, the Cheektowaga Town Board adopted Local Law No. 2 of the Year 1990, entitled "A Local Law to create the Cheektowaga Conservation Advisory Council", and

WHEREAS, pursuant to such law, the Cheektowaga Town Board appointed voting members to such Cheektowaga Conservation Advisory Council ("CCAC"), and

WHEREAS, the terms of such members of the CCAC expired on October 15, 2014, and

WHEREAS, the existing members of the CCAC have expressed an interest in continuing to serve on the CCAC, NOW, THEREFORE, BE IT

RESOLVED, that the following individuals be and hereby are re-appointed to the CCAC, effective October 15, 2014 to October 15, 2016:

Frederic Beaman, AIA Architect, Chairman
 Lawrence Watson, Member
 Lorraine Aloisio, Member
 Rosalia Becker, Member
 Joseph Fischer, Member
 Patricia Beaman, Member
 Robert Becker, Member

, and BE IT FURTHER

RESOLVED, that the following individuals be and hereby are appointed as ex-officio members of the CCAC, effective from October 15, 2014 to October 15, 2016:

Jane Wiercioch, Member, Zoning Board of Appeals
 Daniel Ulatowski, Town Planner
 Stanley J. Kaznowski, III, Chairman, Planning Board

RESULT:	ADOPTED [UNANIMOUS]
MOVER:	Timothy J. Meyers, Councilmember
SECONDER:	Mary Holtz, Supervisor
AYES:	Holtz, Rogowski, Kaminski, Wozniak, Benczkowski, Meyers



17. RESOLUTION 2014-576

Appointment of Two (2) Public Safety Dispatchers (Competitive/Permanent) Police Department/Julianne E. Astyk and Ashley N. Arena

Sponsored By: Councilmember Benczkowski, Councilmember Kaminski

WHEREAS, two (2) vacancies exist in the position of Public Safety Dispatcher in the Police Department; AND

WHEREAS, said vacancies are in the competitive class of civil service; AND

WHEREAS, the existing civil service list was canvassed and interviews conducted;
NOW, THEREFORE, BE IT

RESOLVED, that the following be and hereby are appointed to the position of Public Safety Dispatcher in the Police Department at a salary in accordance with the collective bargaining agreement between the Town of Cheektowaga and the Town of Cheektowaga Public Safety Dispatchers Association effective November 3, 2014:

1. Julianne E. Astyk, Cheektowaga, New York
2. Ashley N. Arena, Cheektowaga, New York; AND, BE IT FURTHER

RESOLVED, that these Public Safety Dispatchers' seniority be based on the order of their appointment as enumerated above.

RESULT:	ADOPTED [UNANIMOUS]
MOVER:	Diane Benczkowski, Councilmember
SECONDER:	Gerald Kaminski, Councilmember
AYES:	Holtz, Rogowski, Kaminski, Wozniak, Benczkowski, Meyers



18. RESOLUTION 2014-577

Youth & Recreation Hire/Transfers

Sponsored By: Councilmember Wozniak, Councilmember Rogowski

BE IT RESOLVED that the individuals listed below be and herby are hired in the Department of Youth & Recreational Services effective as indicated:

Recreation Attendant - 7140.1664 - \$10.00 - Regular Part-time

Gayle Anthony 14225

Recreation Attendant - 7310.1803 - Regular Part-time - \$8.00 - Retro to 9/29/14

Tracey Marlinski 14227

BE IT FURTHER RESOLVED that the individuals listed below be and herby are transferred in the Department of Youth & Recreational Services effective immediately:

Recreation Attendant - Seasonal - to Recreation Attendant - Regular Part-time - \$8.00 - 7140.1648 & 7140.1614

Bailey Michalski

Lennox Melin

Recreation Aide - Part-time - to Recreation Attendant - 7140.1614 - Regular Part-time - \$8.00

Daniel Golinski

Motion by Councilmember Rogowski; Seconded by Councilmember Meyers to waive the reading of names for the following two (2) resolutions: 2014-577 and 2014-578. Motion Carried.

RESULT: ADOPTED [UNANIMOUS]
MOVER: Angela M. Wozniak, Councilmember
SECONDER: James P. Rogowski, Councilmember
AYES: Holtz, Rogowski, Kaminski, Wozniak, Benczkowski, Meyers



19. RESOLUTION 2014-578

Hiring/Termination of Part-Time/Seasonal Employees

Sponsored By: Councilmember Kaminski, Supervisor Holtz

BE IT RESOLVED, that the following individuals be and hereby are hired as **PART-TIME EMPLOYEES** in the departments listed, not to exceed nineteen (19) hours on a weekly basis, in compliance with Civil Service Laws and Regulations as well as the provisions of the Town's collective bargaining agreement between the Town of Cheektowaga and the Town of Cheektowaga Employees Association:

POLICE DEPARTMENT Student Assistant \$8.00/hour effective 10/21/14
Brad J. Bauman, Cheektowaga, New York

POLICE DEPARTMENT Police Attendant \$17.10/hour effective 10/21/14
Garrett W. Jacobs, Depew, New York

SENIOR SERVICES Van Driver \$9.25/hour effective 10/21/14
Jerome H. Lewandowski, Cheektowaga, New York

BE IT RESOLVED, that the following seasonal and/or part-time employees be and hereby are terminated as listed:

FACILITIES DEPARTMENT
Ryan J. Kowal effective 8/10/14
Kyle J. Lacki effective 8/18/14
Mark P. Stucke, Sr. effective 8/28/14
Michael P. Tomczak effective 8/31/14
Michael D. Wawrzyniak effective 9/1/14
Michael P. Wierzba effective 8/24/14

RESULT:	ADOPTED [UNANIMOUS]
MOVER:	Gerald Kaminski, Councilmember
SECONDER:	Mary Holtz, Supervisor
AYES:	Holtz, Rogowski, Kaminski, Wozniak, Benczkowski, Meyers



20. RESOLUTION 2014-579

Travel Authorization Police Department/Detective Michael Hockwater and Detective Robert Laskowski

Sponsored By: Councilmember Benczkowski, Councilmember Kaminski

WHEREAS, the 40th Annual Arson Seminar is being held November 5 through November 7, 2014 in Montour Falls, New York; AND

WHEREAS, Detectives Michael Hockwater and Robert Laskowski have been recommended to attend said seminar; AND

WHEREAS, Police Chief David Zack has submitted a request for travel authorization along with the proper paperwork in a timely manner; AND

WHEREAS, the total cost to the Town shall not exceed \$482; AND

WHEREAS, these expenses have been budgeted by the Department; NOW, THEREFORE, BE IT

RESOLVED, that Detectives Michael Hockwater and Robert Laskowski be and hereby are authorized to attend the 40th Annual Arson Seminar being held November 5 through November 7, 2014 in Montour Falls, New York.

RESULT:	ADOPTED [UNANIMOUS]
MOVER:	Diane Benczkowski, Councilmember
SECONDER:	Gerald Kaminski, Councilmember
AYES:	Holtz, Rogowski, Kaminski, Wozniak, Benczkowski, Meyers

V. Suspension of Rules

Motion by Councilmember Rogowski; Seconded by Councilmember Meyers to Waive the Rules to Include the following five (5) Resolutions: 2014-580; 2014-581; 2014-582; 2014-583 and 2014-584. Motion Carried.



1. RESOLUTION 2014-580

Award of Bid for Demolition and Asbestos Abatement of 42 Avery Place (BID 2014-31 LAW)

Sponsored By: Supervisor Holtz, Councilmember Benczkowski

WHEREAS, by Resolution 2014-457 this Town Board rejected bids received and opened on July 30, 2014 for the Demolition and Asbestos Abatement of structures at 42 Avery Place (BID 2014-31 LAW) and directed that said project be re-bid; and

WHEREAS, bids were received and opened on August 27, 2014 for said demolition and asbestos abatement; and

WHEREAS, the proposals received on August 27, 2014 were reviewed by the Town Attorney, who has recommended that this Town Board award the bid for the demolition and asbestos abatement of the structures at 42 Avery Place to Regional Environmental Demolition, Inc.; NOW, THEREFORE, BE IT

RESOLVED, that this Town Board hereby awards the bid for the demolition and asbestos abatement of structures located at 42 Avery Place to:

Regional Environmental Demolition, Inc.
3695 Pine Avenue
Niagara Falls, New York

for the bid price of \$48,000.00, said amount being the lowest responsible bid which meets specifications; and BE IT FURTHER

RESOLVED, that the Supervisor be and hereby is directed to execute an agreement with Regional Environmental Demolition, Inc., for the aforesaid services, and BE IT FURTHER

RESOLVED, that moneys for said services shall be appropriated from budget line item number 0800-800-0440.

RESULT:	ADOPTED [UNANIMOUS]
MOVER:	Mary Holtz, Supervisor
SECONDER:	Diane Benczkowski, Councilmember
AYES:	Holtz, Rogowski, Kaminski, Wozniak, Benczkowski, Meyers



2. RESOLUTION 2014-581

Authorize Purchase of Copy Machine for Police Department

Sponsored By: Supervisor Holtz, Councilmember Benczkowski

WHEREAS, due to heavy usage and age, the copy machine in the Police Department is experiencing many breakdowns requiring frequent service calls and maintenance; and

WHEREAS, Toshiba America Business Solutions, Inc. was awarded a bid through the New York State Office of General Services for various Toshiba copy machines (New York State Contract No. PT66215); and

WHEREAS, a local vendor, Eagle Systems, Inc., is an authorized reseller/distributor for Toshiba under said State contract; and

WHEREAS, the Town of Cheektowaga solicited a quotation from Eagle Systems for a Toshiba e-Studio 3055C Copier through said State contract; and

WHEREAS, funds for said purchase have been budgeted and are available; NOW, THEREFORE, BE IT

RESOLVED, that this Town Board agrees to purchase the aforesaid copy machine through the following contract awarded by the New York State Office of General Services utilizing a local reseller/distributor, Eagle Systems, Inc., 2421 Harlem Road, Cheektowaga, New York 14225:

Group No. 22424

Contract Award No. 75525

Authorized Contractor: Toshiba America Business Solutions, Inc.,

for a total cost of \$5,732.00, said pricing to include delivery, surge protectors, installation on servers or three workstations, and removal and return of the hard drive on the present copier to the Town of Cheektowaga for destruction; and BE IT FURTHER

RESOLVED, that the cost per copy for maintenance and supplies for said copier will be added to an existing Town contract and will be \$0.008 per black and white copy and \$.06 per color copy; and BE IT FURTHER

RESOLVED, that moneys for said purchase shall be appropriated from Police Department account number 100-3020-4029; and BE IT FURTHER

RESOLVED, that the Supervisor be and hereby is authorized and directed to execute all documents and maintenance agreements with Eagle Systems, Inc., to effectuate said purchase, subject to the review and approval of same by the Town Attorney.

RESULT: **ADOPTED [UNANIMOUS]**
MOVER: Mary Holtz, Supervisor
SECONDER: Diane Benczkowski, Councilmember
AYES: Holtz, Rogowski, Kaminski, Wozniak, Benczkowski, Meyers



3. RESOLUTION 2014-582

Negative SEQR Declaration - 93 Maryvale Drive T- Mobile Co-Location

Sponsored By: Councilmember Meyers, Supervisor Holtz

WHEREAS, pursuant to the Environmental Impact Review Ordinance of the Town of Cheektowaga, the Environmental Advisory Committee ("EAC") reviews various applications for site plans, rezonings, special permits, etc. and renders its recommendation concerning the environmental significance of such application, AND

WHEREAS, an application was submitted by Richard Hanson, representing T-Mobile Northeast, LLC for the co-location of telecommunication antennas on an existing monopole communications tower at 93 Maryvale Drive, AND

WHEREAS, the Town Board, pursuant to the Environmental Impact Review Ordinance of the Town of Cheektowaga, is the Lead Agency, AND

WHEREAS, since the Town Board is the Lead Agency, it must affirm, modify or reject any recommendations submitted to it by the Advisory Committee, AND

WHEREAS, the existing monopole telecommunications tower is 139 feet in height, and the applicant's antennas will be mounted at a height of 126 feet, not requiring a tower extension, AND

WHEREAS, the Town of Cheektowaga Planning Board recommended approval of the special use permit at their meeting of August 14, 2014, AND

WHEREAS, the Environmental Advisory Committee at its meetings held on August 20, 2014 recommended a determination of non-significance, AND

WHEREAS, this Town Board has reviewed the application submitted and the recommendations made by the Environmental Advisory Committee and the Planning Board NOW, THEREFORE, BE IT

RESOLVED, that this Town Board determines that the project will not have a significant effect on the environment and therefore issues a Negative Declaration for purposes of the State Environmental Quality Review Act (SEQRA).

RESULT:	ADOPTED [UNANIMOUS]
MOVER:	Timothy J. Meyers, Councilmember
SECONDER:	Mary Holtz, Supervisor
AYES:	Holtz, Rogowski, Kaminski, Wozniak, Benczkowski, Meyers



4. RESOLUTION 2014-583

Approve Special Use Permit for 93 Maryvale Drive

Sponsored By: Councilmember Benczkowski, Councilmember Meyers

WHEREAS, T-Mobile Northeast, LLC has applied for a Special Use Permit to co-locate a new cellular communications facility on an existing 139-foot-high cell tower on property owned by For the Love of Cooking, LLC and located at 93 Maryvale Drive, Cheektowaga, New York, pursuant to Sections 260-47 of the Code of the Town of Cheektowaga (“Zoning Law”), and Chapter 255 of the Town Code (“Wireless Telecommunications Facilities”); and

WHEREAS, a public hearing was held before the Cheektowaga Town Board on the 6th day of October, 2014 at 6:45 P.M. of said day for the purpose of considering said application for a Special Permit, after publication and service of the notices required by the provisions of the Zoning Law and the Town Law; and all interested parties were given an opportunity to be heard at such hearing; and

WHEREAS, the Cheektowaga Planning Board has recommended approval of this Special Permit; and

WHEREAS, this Town Board previously issued a Negative Declaration under SEQRA for this project; NOW, THEREFORE BE IT

RESOLVED, that the aforesaid Special Use Permit for co-locating a new cellular communications facility on an existing 139-foot-tall cell tower at 93 Maryvale Drive be and hereby is granted.

LEGAL DESCRIPTION FOR SPECIAL PERMIT

All that tract or parcel of land situate in Town of Cheektowaga, County of Erie, and State of New York, being part of Lot No. 35, Township 11, Range 7 of the Holland Land Company’s Survey, described as follows:

BEGINNING at a point in the southerly line of Maryvale Drive (formerly Pine Ridge Road) distant 160 feet west from the east line of Lot No. 35, said east line of Lot No. 35, being also the west line of Harlem Road as laid out as a 66 foot highway; thence southerly parallel with the east line of Lot No. 35 a distance of 175 feet to a point; thence westerly parallel with Maryvale Drive, a distance of 90 feet to a point; thence northerly parallel with the east line of Lot No. 35 a distance of 175 feet to a point in the southerly line of Maryvale Drive; thence easterly along the southerly line of Maryvale Drive 90 feet to the point or place of beginning.

RESULT: **ADOPTED [UNANIMOUS]**
MOVER: Diane Benczkowski, Councilmember
SECONDER: Timothy J. Meyers, Councilmember
AYES: Holtz, Rogowski, Kaminski, Wozniak, Benczkowski, Meyers



5. RESOLUTION 2014-584

Change of Date for Bonfire for JFK High School

Sponsored By: Supervisor Holtz, Councilmember Benczkowski

WHEREAS, by resolution dated September 15, 2014 (Resolution No. 2014-511), this Town Board authorized JFK High School to hold a bonfire at 305 Cayuga Creek Road on Friday, October 24, 2014, and

WHEREAS, JFK High School has changed the date for said bonfire to Saturday, October 25., 2014, and

WHEREAS, the Fire Inspector has recommended approval of the change of date for this bonfire, NOW, THEREFORE, BE IT

RESOLVED, that this Town Board hereby approves the application of JFK High School to hold a bonfire oat 305 Cayuga Creek Road for Saturday, October 25, 2014, and BE IT FURTHER

RESOLVED, that this Town Board hereby authorizes the Fire Inspector to issue a permit for said bonfire on October 25, 2014

RESULT:	ADOPTED [UNANIMOUS]
MOVER:	Mary Holtz, Supervisor
SECONDER:	Diane Benczkowski, Councilmember
AYES:	Holtz, Rogowski, Kaminski, Wozniak, Benczkowski, Meyers

VI. Communications

A. Departmental Communications

1. **Town of Cheektowaga Emergency Services Quarterly Report from July to September 2014**
2. **Minutes: Cheektowaga Public Library - Board of Trustees - September 17, 2014**
3. **Building Permit List - August 2014**
4. **Building Permit List - September 2014**

B. General Communications

1. **Summons: Bank of America, N.A. vs. Gregory Guzek; Crystal Guzek; and The Town of Cheektowaga Premises: 226 Cass Avenue**
2. **Summons & Complaint: Eugene Czajkowski vs. Town of Cheektowaga**
3. **Notice of Claim: Claire Buchbinder vs. Town of Cheektowaga**
4. **Notice of Claim: Kevin R. Hammann vs. Town of Cheektowaga**
5. **Notice of Claim: NYCM Inc. for Donna Duszczak vs. Town of Cheektowaga**
6. **Notice of Claim: Kobie Watford vs. Town of Cheektowaga**

VII. Comments***A. Supervisor's Comments******B. Councilmember's Comments******C. Public Comments*****VIII. Adjournment**

Motion by Supervisor Holtz; Seconded by Councilmember Rogowski to adjourn the meeting at 8:20 PM.

Alice Magierski, Town Clerk

KEY PLAN

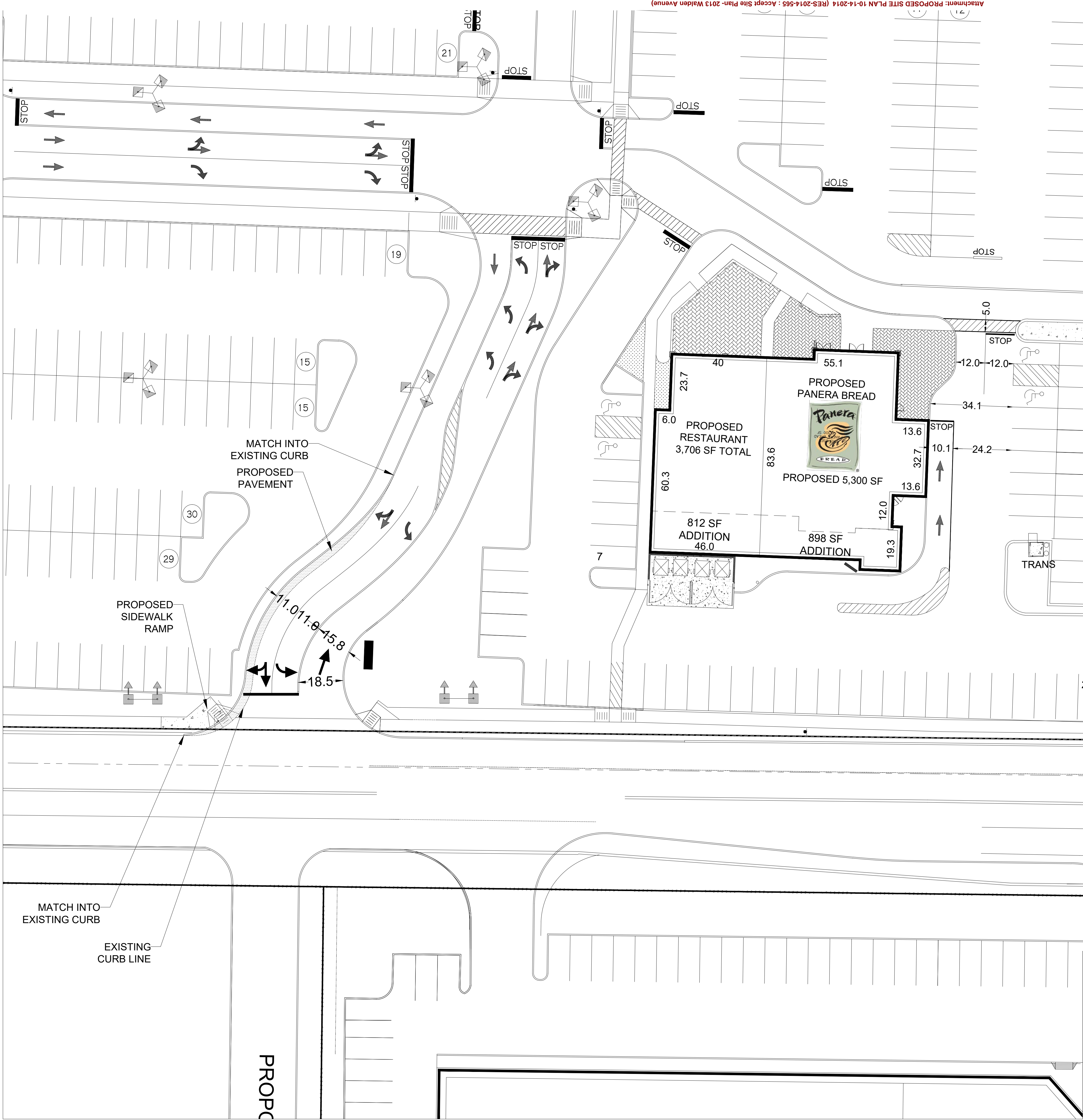
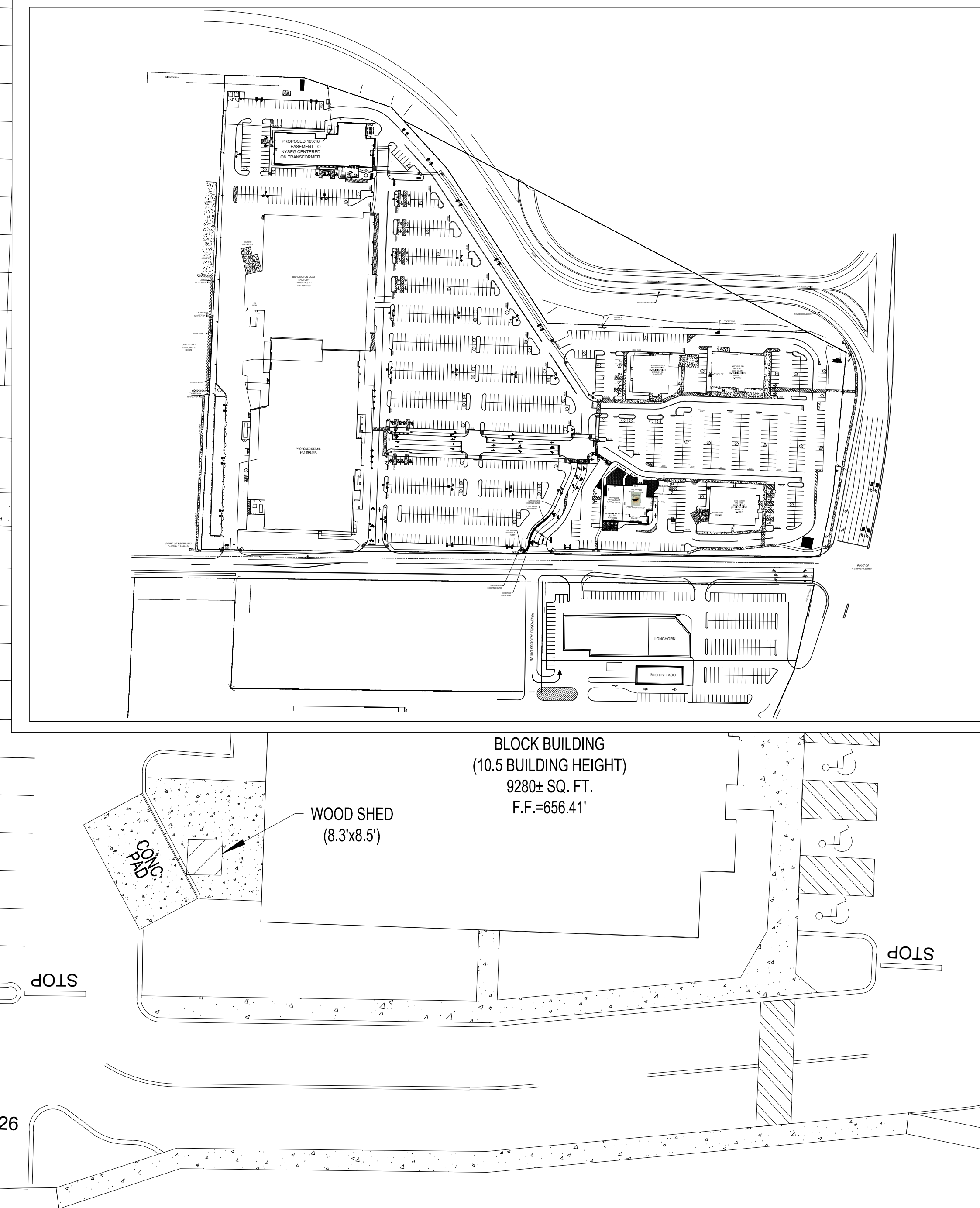

Attachment: PROPOSED SITE PLAN 10-14-2014 (RES-2014-565 : Accept Site Plan- 2013 Walden Avenue)

4.6.a

Packet Pg. 37

MATCH INTO EXISTING CURB
PROPOSED PAVEMENT

PROPOSED SIDEWALK RAMP

MATCH INTO EXISTING CURB
EXISTING CURB LINE

PROPC

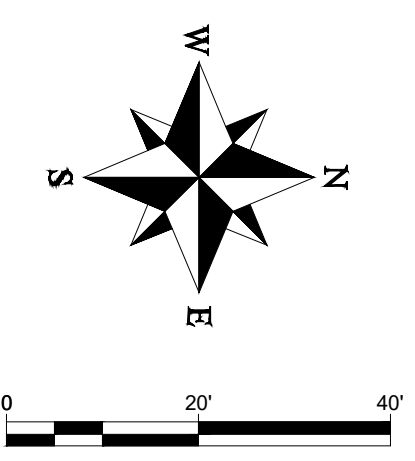

CABELA'S CROSSING
WALDEN AVE
CHEEKTOWAGA, NY

4910 PROPOSED SITE PLAN 10-14-2014 OCTOBER 14, 2014

BENDERSON DEVELOPMENT COMPANY, LLC
570 DELAWARE AVE. BUFFALO, NY 14202
PHONE: (716) 855-0211 FAX: (716) 855-7791
WWW.BENDERSON.COM

CONCEPT PLAN

DRAWN BY: DMN CHECKED BY: MAO SCALE: 1:20



Town of Cheektowaga

Special Meeting

~ Minutes ~

3301 Broadway
Cheektowaga, NY 14227
<http://www.town.cheektowaga.ny.us>

Alice Magierski
716-686-3400

Tuesday, October 28, 2014

5:30 PM

Council Chambers

I. Call to Order

5:30 PM Meeting called to order on October 28, 2014 at Council Chambers, 3301 Broadway St, Cheektowaga, NY.

Attendee Name	Organization	Title	Status	Arrived
Mary Holtz	Town of Cheektowaga	Supervisor	Present	
James P. Rogowski	Town of Cheektowaga	Councilmember	Present	
Gerald Kaminski	Town of Cheektowaga	Councilmember	Present	
Angela M. Wozniak	Town of Cheektowaga	Councilmember	Present	
Diane Benczkowski	Town of Cheektowaga	Councilmember	Present	
Timothy J. Meyers	Town of Cheektowaga	Councilmember	Present	

2. Additional Attendees

Patrick Bowen, Town Engineer
Ellen Fischer, Executive Director - Youth Board
Stanley Kaznowski, III, Planning Board Chairman
Carla A. Kosmerl, Director of Community Development
Brian Krause, Director of Finance and Administration
Jeneen Lomando-McSkimming, Assessor
Karen Marchese, Coordinator of Employee Relations
Jon Nichy, Superintendent of Wastewater Pump Station
Kevin Schenk, Town Attorney
Kerry Switalski, Senior Services Director

II. Public Portion

III. Public Hearings

1. 2015 Preliminary Ad Valorem Budget

COMMENTS - Current Meeting:

This being the time and place advertised for a Public Hearing, the Supervisor directed the Town Clerk to present that such notice has been duly published and posted; upon the order of the Supervisor such proof was duly filed.

The Supervisor announced that the Town Board would hear all persons interested in the subject of the hearing. Comments were heard, after which the Supervisor declared the hearing closed, decision was reserved.

RESULT: CLOSED [UNANIMOUS]
MOVER: Mary Holtz, Supervisor
SECONDER: Gerald Kaminski, Councilmember
AYES: Holtz, Rogowski, Kaminski, Wozniak, Benczkowski, Meyers

2. 2015 Benefit Basis Budget

COMMENTS - Current Meeting:

This being the time and place advertised for a Public Hearing, the Supervisor directed the Town Clerk to present that such notice has been duly published and posted; upon the order of the Supervisor such proof was duly filed.

The Supervisor announced that the Town Board would hear all persons interested in the subject of the hearing. Comments were heard, after which the Supervisor declared the hearing closed, decision was reserved.

RESULT: CLOSED [UNANIMOUS]
MOVER: Mary Holtz, Supervisor
SECONDER: Gerald Kaminski, Councilmember
AYES: Holtz, Rogowski, Kaminski, Wozniak, Benczkowski, Meyers

IV. Adjourn

Motion by Supervisor Holtz: Seconded by Councilmember Rogowski to adjourn the Public Hearings at 5:58 PM

Alice Magierski, Town Clerk



Town of Cheektowaga

Work Session

~ Minutes ~

3301 Broadway
Cheektowaga, NY 14227
<http://www.town.cheektowaga.ny.us>

Alice Magierski
716-686-3400

Tuesday, October 28, 2014

6:00 PM

Council Office

I. Call to Order

6:00 PM Meeting called to order on October 28, 2014 at Council Office, Conference Room, Cheektowaga, NY.

Attendee Name	Organization	Title	Status	Arrived
Mary Holtz	Town of Cheektowaga	Supervisor	Present	
James P. Rogowski	Town of Cheektowaga	Councilmember	Present	
Gerald Kaminski	Town of Cheektowaga	Councilmember	Present	
Angela M. Wozniak	Town of Cheektowaga	Councilmember	Present	
Diane Benczkowski	Town of Cheektowaga	Councilmember	Present	
Timothy J. Meyers	Town of Cheektowaga	Councilmember	Present	

II. Resolutions



1. RESOLUTION 2014-585

Designation of Halloween Night

Sponsored By: Supervisor Holtz, Councilmember Rogowski

WHEREAS, the children of our community are entitled to the fun and excitement associated with "Halloween Night", including going from door-to-door in their immediate neighborhoods with their happy challenges of trick-or-treat; AND

WHEREAS, it would appear that parents generally favor the early evening hours, since it tends to limit participation to the younger children, for whom the observance was originally intended and thereby discourages interference and disruption by the very small percentage of older children, who under cover of darkness and with their identities concealed and costumes, might otherwise spoil the fun for the smaller children, NOW, THEREFORE, BE IT

RESOLVED, that Friday, October 31, 2014 shall be known as "Halloween Night" in the Town of Cheektowaga, and that the Town Board ask both children and their parents to cooperate in limiting the time of "trick-or-treating" activities to the period between 6:00 P.M. and 8:00 P.M. We further ask that, whenever possible, parents of the very young insure that they or other responsible adults accompany them, and to cooperate in making this a happy occasion for all youngsters by keeping their porch or exterior lights on.



"DESIGNATION OF HALLOWEEN NIGHT"

BE IT RESOLVED, that Friday, October 31, 2014 be designated as "HALLOWEEN NIGHT" in the Town of Cheektowaga.

The time of "trick-or-treating" activities will be between 6:00 P.M. and 8:00 P.M.

We encourage all householders to cooperate in making this a happy occasion for all youngsters by keeping their porch or exterior lights on.

HAPPY HALLOWEEN TO ALL!

BY ORDER OF THE TOWN BOARD
OF THE TOWN OF CHEEKTOWAGA,
ERIE COUNTY, NEW YORK

Alice Magierski, Town Clerk

RESULT: **ADOPTED [UNANIMOUS]**
MOVER: Mary Holtz, Supervisor
SECONDER: James P. Rogowski, Councilmember
AYES: Holtz, Rogowski, Kaminski, Wozniak, Benczkowski, Meyers



2. RESOLUTION 2014-586

Authorize Supervisor to execute Agreement with HARBORCENTER

Sponsored By: Councilmember Wozniak, Councilmember Rogowski

WHEREAS, ice/hockey rinks at HARBORCENTER in downtown Buffalo are now open for use by youth hockey organizations in Western New York, and

WHEREAS, the Department of Youth & Recreational Services is interested in leasing ice rinks in said facility for HARBORCENTER's Youth Development Program, and

WHEREAS, in order to utilize HARBORCENTER, the Town must enter into a Facility Agreement, and

WHEREAS, a Facility Agreement has been prepared to authorize the Cheektowaga Rec Hockey to use the rinks at HARBORCENTER and to receive hockey specific training from the Academy of Hockey and Impact Sports Performance from October 30, 2014 to March 24, 2015, NOW, THEREFORE, BE IT

RESOLVED, that the Supervisor be and hereby is authorized and directed to execute said Facility Agreement, and BE IT FURTHER

RESOLVED, that the fee for said hockey ice rental and training, \$6,600.00, shall be appropriated from the Youth & Recreational Services Department's budget.

RESULT:	ADOPTED [UNANIMOUS]
MOVER:	Angela M. Wozniak, Councilmember
SECONDER:	James P. Rogowski, Councilmember
AYES:	Holtz, Rogowski, Kaminski, Wozniak, Benczkowski, Meyers

III. Adjournment

Motion by Supervisor Holtz; Seconded by Councilmember Rogowski to move into Executive Session.

Alice Magierski, Town Clerk



Town of Cheektowaga

Regular Meeting

~ Minutes ~

3301 Broadway
Cheektowaga, NY 14227
<http://www.town.cheektowaga.ny.us>

Alice Magierski
716-686-3400

Monday, November 3, 2014

6:45 PM

Council Chambers

I. Call to Order

6:45 PM Meeting called to order on November 3, 2014 at Council Chambers, 3301 Broadway St, Cheektowaga, NY.

Attendee Name	Organization	Title	Status	Arrived
Mary Holtz	Town of Cheektowaga	Supervisor	Present	
James P. Rogowski	Town of Cheektowaga	Councilmember	Present	
Gerald Kaminski	Town of Cheektowaga	Councilmember	Present	
Angela M. Wozniak	Town of Cheektowaga	Councilmember	Present	
Diane Benczkowski	Town of Cheektowaga	Councilmember	Present	
Timothy J. Meyers	Town of Cheektowaga	Councilmember	Present	

2. Additional Attendees

Patrick Bowen, Town Engineer
Brian Krause, Director of Finance and Administration
Karen Marchese, Coordinator of Employee Relations
Kevin Schenk, Town Attorney

II. Public Comment Period

III. Resolutions



1. RESOLUTION 2014-587

Transfer of Funds

Sponsored By: Councilmember Kaminski, Supervisor Holtz

BE IT RESOLVED, that the following transfer is hereby approved and made part hereof;

HUD

FROM:	900.8600.4910	NYS AHC Revenues	\$112,500.00
-------	---------------	------------------	--------------

TO:	900.8668.4010	Loans from Program	\$112,500.00
-----	---------------	--------------------	--------------

GENERAL

FROM:	100.7620.4432	Repairs/Maintenance	\$5,600.00
-------	---------------	---------------------	------------

	100.7620.4261	Postage	200.00
--	---------------	---------	--------

	100.7620.4088	Travel/Training	1,200.00
--	---------------	-----------------	----------

TO:	100.7620.4491	Special Events	\$7,000.00
-----	---------------	----------------	------------

RESULT: **ADOPTED [UNANIMOUS]**

MOVER: Gerald Kaminski, Councilmember

SECONDER: Mary Holtz, Supervisor

AYES: Holtz, Rogowski, Kaminski, Wozniak, Benczkowski, Meyers



2. RESOLUTION 2014-588

Warrant

Sponsored By: Councilmember Kaminski, Supervisor Holtz

BE IT RESOLVED, that the following Vouchers & Warrants submitted to the Town of Cheektowaga prior to November 3, 2014 are hereby approved and made part hereof;

GENERAL FUND	\$3,195,762.18
RISK RETENTION FUND	969,041.97
NYS HOME PROGRAM	0.00
DEBT	424,000.00
HUD HOUSING REHABILITATION FUND	20,805.00
SPECIAL DISTRICTS FUND	793,481.68
HIGHWAY FUND	597,034.23
CAPITAL FUND	430,639.36
TRUST & AGENCY FUND	10,478.19
HUD CDBG FUND	3,492.31
PART TOWN FUND	133,443.39
NYS AFFORDABLE HOUSING	0.00
	<hr/>
	\$6,578,178.31

RESULT:	ADOPTED [UNANIMOUS]
MOVER:	Gerald Kaminski, Councilmember
SECONDER:	Mary Holtz, Supervisor
AYES:	Holtz, Rogowski, Kaminski, Wozniak, Benczkowski, Meyers



3. RESOLUTION 2014-589

Adopt Ad Valorem Budget for 2015

Sponsored By: Holtz, Rogowski, Kaminski, Wozniak, Benczkowski, Meyers

WHEREAS, officers and employees in charge of the various administrative units of the government of the Town of Cheektowaga have submitted estimate of revenues and expenditures for the 2015 fiscal year, AND

WHEREAS, the Supervisor, as the Town's Budget Officer, has caused a tentative budget to be prepared, and the Town Clerk has presented such budget to this Town Board, AND

WHEREAS, this Town Board has met and considered the preliminary budget for the fiscal year beginning January 1, 2015, and a public hearing was conducted there on October 28, 2014 as required by Section 108 of the Town Law, NOW, THEREFORE, BE IT

RESOLVED, that the preliminary budget as changed, altered and revised and as hereinafter set forth, is hereby adopted as the annual budget of the Town of Cheektowaga for the fiscal year beginning on January 1, 2015.

RESULT:	ADOPTED [UNANIMOUS]
MOVER:	Mary Holtz, Supervisor
SECONDER:	James P. Rogowski, Councilmember
AYES:	Holtz, Rogowski, Kaminski, Wozniak, Benczkowski, Meyers



4. RESOLUTION 2014-590

Adopt Benefit Basis Budget for 2015

Sponsored By: Holtz, Rogowski, Kaminski, Wozniak, Benczkowski, Meyers

WHEREAS, Mary F. Holtz, Supervisor of the Town of Cheektowaga, New York, presented a Budget and Assessment Roll showing the various sums of money that were and will be required to defray the expenses of the Special Districts respectively and does determine same to be necessary and required as set forth, namely:

Town of Cheektowaga Final Benefit Basis Budget, AND

WHEREAS, a Public Hearing was duly held on the 28th day of October, 2014 at 5:30 P.M. in relation to the Preliminary Benefit Basis Budget, as provided by law, with amendments made to same, NOW, THEREFORE, BE IT

RESOLVED, that the Budget and Assessment Roll for Special Districts in the Town of Cheektowaga, be and the same is hereby adopted, AND, BE IT FURTHER

RESOLVED, that the Supervisor be and hereby is directed to cause same to be spread on the Tax Roll for the Year 2015.

RESULT:	ADOPTED [UNANIMOUS]
MOVER:	Mary Holtz, Supervisor
SECONDER:	James P. Rogowski, Councilmember
AYES:	Holtz, Rogowski, Kaminski, Wozniak, Benczkowski, Meyers



5. RESOLUTION 2014-591

Change Order No. 1 - Firing Range Shelter

Sponsored By: Councilmember Benczkowski, Councilmember Kaminski

WHEREAS, the contract to construct the Firing Range Shelter located on Scott Place was awarded by Town Board Resolution dated September 15, 2014 to Building Innovation Group, Inc. in the amount of \$390,943.00, AND

WHEREAS, upon meeting with said contractor, several bid items were either revised or removed in an effort to reduce the cost of construction, AND

WHEREAS, the Town Engineer has recommended the approval of Change Order No. 1 which provides for various revisions to the contract which amount to substantial credits as further outlined in the change order document and memo from the Engineering Department dated October 1, 2014, NOW, THEREFORE, BE IT

RESOLVED, that Change Order No. 1 for the construction of the Firing Range Shelter be and hereby is approved as a credit to the Town in the amount of \$64,246.00 and a reduction to the contract with Building Innovation Group, Inc., 107 Lincoln Parkway, East Rochester, New York 14445, AND, BE IT FURTHER

RESOLVED, that the Supervisor, on behalf of this Town Board, is hereby authorized to execute said change order documents with Building Innovation Group, Inc.

RESULT:	ADOPTED [UNANIMOUS]
MOVER:	Diane Benczkowski, Councilmember
SECONDER:	Gerald Kaminski, Councilmember
AYES:	Holtz, Rogowski, Kaminski, Wozniak, Benczkowski, Meyers



6. RESOLUTION 2014-592

Notice of Public Hearing - Amend Prior Year Annual Plans

Sponsored By: Councilmember Kaminski, Supervisor Holtz

WHEREAS, the Town has received Community Development Block Grant funds and Home Investment Partnership program funds from the U.S. Department of HUD, and

WHEREAS, the Town wishes to change the uses initially proposed for those funds, and

WHEREAS, the Town is required to hold public hearings to obtain the views of Town residents, public agencies and other interested parties on proposed changes to the use of those funds, NOW, THEREFORE, BE IT

RESOLVED, that a public hearing be held on November 17, 2014 at 6:45 P.M. at Cheektowaga Town Hall, 3301 Broadway, Cheektowaga, New York 14227 for the above stated purpose, and BE IT

FURTHER RESOLVED, that the attached public notice of such public hearing be published in the Cheektowaga Bee on Thursday, November 6, 2014.

BY ORDER OF THE TOWN BOARD OF THE TOWN OF CHEEKTOWAGA, ERIE COUNTY, NEW YORK.



Notice of Public Hearing to Amend Prior Year Annual Plans Community Development Block Grant and HOME Programs

A public hearing will be held on Monday, November 17, 2014 at 6:45 P.M. at Cheektowaga Town Hall, 3301 Broadway, Cheektowaga, NY 14227 on proposed changes to the Town's various prior Annual Plans for the use of Community Development Block Grant (CDBG) and HOME Investment Partnership Act (HOME) Programs, to obtain the views of citizens and interested parties on those proposed changes in housing and community development. The Annual Plan outlines housing and community development projects proposed to be funded with CDBG and HOME Program funds for a grant year. The proposed changes, outlined below, will be made available for public review in Town Hall, the Community Development Office, Cheektowaga Branch Libraries, and the Cheektowaga Bee. Those wishing to offer comments at the hearing are asked to also submit a written text, which may also be submitted to the Cheektowaga Community Development Office, 275 Alexander Avenue, Cheektowaga, New York, 14211. Interpreters will be made available at the meetings upon prior request to sign for the hearing impaired. If you need such special arrangements, contact the Cheektowaga Community Development Office at 897-7200, Ext. 7, at least seven (7) business days prior to the hearing. The hearing location is accessible to the physically disabled.

Town of Cheektowaga
Community Development Block Grant Program
Annual Plan / Final Statement Amendment Report
2013-2014 - #2

The Town of Cheektowaga's Annual Plan / Final Statement on the Use of Community Development Block Grant and HOME Investment Partnership Funds is amended as follows:

Activities Added

(Activities added to include the acquisition of two - 12 Passenger Vans and one - 15 Passenger Wheelchair Accessible Van)

1.	Cheektowaga Senior Citizen Van Acquisition	2014	\$ 105,173.39
	Total		<u>\$ 105,173.39</u>

Activities Modified

(Funding adjusted for actual need and actual expenditures)

1.	Cheektowaga Economic Development Activity	2002	\$ (1.00)
2.	Neighborhood Preservation Activities	2008	(1,112.48)
3.	Contingency	2013	(2,425.00)
4.	Summer Day Camp	2014	(4,306.25)
5.	Housing Rehabilitation - Single Family	2014	43,950.38
6.	Village of Sloan/Drainage & Sewer Improvements	2007	(20,125.65)
7.	Village of Sloan/Drainage & Sewer Improvements	2011	(15,980.00)
8.	Housing Rehabilitation - Single Family	2013	(35,051.93)
9.	Rehab Activity Delivery Costs	2013	42,144.80
10.	Acquisition	1998	(1,314.00)
11.	Property Purchases	2006	(500.00)
12.	Clearance/Demolition	1998	(1,242.52)
13.	Youth Companionship Program	1997	(464.00)
14.	Temporary Relocation Assistance	2004	(501.00)
15.	Housing Rehabilitation - Single Family	2005	(0.50)
16.	Disposition	2006	(397.89)
17.	Neighborhood Preservation Activities	2008	(1,287.96)
18.	Housing Counseling Services	2013	1,870.00
19.	Acquisition	2010	(3,248.72)
20.	Environmental Hazard Testing	2012	(6.28)
21.	Housing Rehabilitation - Single Family	2011	(105,173.39)
	Total		<u>\$(105,173.99)</u>

RESULT:	ADOPTED [UNANIMOUS]
MOVER:	Gerald Kaminski, Councilmember
SECONDER:	Mary Holtz, Supervisor
AYES:	Holtz, Rogowski, Kaminski, Wozniak, Benczkowski, Meyers



7. RESOLUTION 2014-593

Notice To Bidders for Furnishing Equipment and Operators for the Clean-Up and Board-Up of Various Properties (BID 2014-32 CD)

Sponsored By: Benczkowski, Kaminski, Holtz

WHEREAS, under the direction of the Community Development Department, the Office of Housing & Neighborhood Preservation is responsible for inspecting various properties within the Town of Cheektowaga to ensure compliance with residential and commercial property maintenance codes, and

WHEREAS, maintenance of these properties sometimes includes boarding up/securing structures and minor demolition of structures and other related work, and

WHEREAS, when violations are noted, property owners are notified to maintain and secure their properties, and

WHEREAS, in the event property owners do not comply with these orders from the Housing & Neighborhood Preservation Office, and public health and safety require that action be taken immediately, it is necessary that the Housing & Neighborhood Preservation Office retain a private contractor to perform the necessary work on the property, and

WHEREAS, due to the projected annual cost for performing this work, it is necessary that this Board advertise for bids for these services, and

WHEREAS, the Building Inspections Department, Housing & Neighborhood Preservation Office and the Town Attorney's Office have drafted bid specifications for this purpose for the remainder of calendar year 2014 plus calendar year 2015, NOW, THEREFORE, BE IT

RESOLVED, that the Town Clerk be and hereby is directed to publish a Notice to Bidders for Furnishing Equipment and Operators for the Clean Up, Etc. for Various Properties in the Town of Cheektowaga (BID 2014-32 CD) in the Cheektowaga Bee, and BE IT FURTHER

RESOLVED, that bids will be received until November 19, 2014 at 11:00 a.m. by the Town Clerk, who is hereby authorized and directed to publicly open all bids received at such time in the Council Chambers in the Cheektowaga Town Hall.



NOTICE TO BIDDERS

Sealed proposals will be received and considered by the Town Board of the Town of Cheektowaga on November 19, 2014 at 11:00 A.M., at the Town Hall, corner of Broadway and Union Roads, for Furnishing Equipment and Operators for the Clean-Up and Board-Up of Various Properties in the Town of Cheektowaga for the Remainder of Calendar Year 2014 Plus

Calendar Year 2015, said services to include installation of padlocks and latches; boarding up of openings, removal of garbage/rubbish and debris, demolitions of minor structures such as sheds, porches, etc.

Information for bidders and specifications may be obtained from the Town Clerk at her office in said Town Hall.

Proposals shall be submitted in a sealed envelope plainly marked on the outside "Bid for Furnishing of Equipment and Operators for the Clean-Up and Board-Up of Various Properties in the Town of Cheektowaga for the Remainder of Calendar Year 2014 Plus Calendar Year 2015 (BID 2014-32 CD)" and submitted to the Town Clerk prior to bid opening.

No bidder may withdraw his bid within forty-five (45) days after the actual date of the opening thereof.

The Town Board reserves the right to consider informal any bid not prepared and submitted in accordance with the provisions of the specifications and contract documents, and may waive any informalities, make an award to other than the low bidder, should it be in the best interest of the Town, or reject any or all bids.

Each proposal must be accompanied by a certified check for a sum equal to five percent (5%) of the amount of the bid, payable to the Town of Cheektowaga, New York, or bond with sufficient sureties to be approved by the attorney for the Town of Cheektowaga, New York.

By order of the Town Board of the Town of Cheektowaga, Erie County, New York.

Alice Magierski, Town Clerk

RESULT:	ADOPTED [UNANIMOUS]
MOVER:	Diane Benczkowski, Councilmember
SECONDER:	Gerald Kaminski, Councilmember
AYES:	Holtz, Rogowski, Kaminski, Wozniak, Benczkowski, Meyers



8. RESOLUTION 2014-594

Abandonment and Sale of a Portion of McKesson Parkway

Sponsored By: Councilmember Kaminski, Supervisor Holtz

WHEREAS, McKesson Parkway, a 70 foot wide road, which runs in an east-west direction, was previously dedicated to the Town of Cheektowaga as a Town highway, and

WHEREAS, PCO Buffalo III, LLC, the owner of the adjacent properties, has made application requesting the discontinuance and purchase of a portion of the above referenced town highway and adjoining land, from the westerly terminus of such highway to a point 600+ feet east of said westerly terminus; and

WHEREAS, the Town Superintendent of Highways has reviewed the application for the discontinuance of said portion of a Town highway and has determined that said portion of the Town highway is useless to the needs of the Town, and that the Town should discontinue same as a highway; and

WHEREAS, the discontinuance and sale of the above referenced portion of the town highway would not negatively affect other property owners in the area, NOW, THEREFORE BE IT

RESOLVED, that this Town Board hereby concurs with the statement made by the Superintendent of Highways that the aforementioned Town Highway is useless to the needs of the Town, and BE IT FURTHER

RESOLVED, that the portion of McKesson Parkway, as described in the attached legal description be and hereby is abandoned as a Town highway subject to the conditions listed below, and BE IT FURTHER

RESOLVED, that this Town Board hereby agrees to convey to PCO Buffalo III, LLC the portion of McKesson Parkway described in the attached legal description for the consideration of One Hundred Thousand and no/100 Dollars (\$100,000.00), subject to the following conditions:

- Final review and approval by the Town Attorney and Town Engineer
- Satisfactory proof that all utility companies having utilities on, under and over the portion of the Town highway to be abandoned have made arrangements to protect their utilities and/or have agreed to abandon same

, and BE IT FURTHER

RESOLVED, that the Supervisor be and hereby is authorized and directed to execute a quit claim deed and all other documents necessary to transfer said Town highway to PCO Buffalo III, LLC.; and BE IT FURTHER

RESOLVED, that this resolution is subject to permissive referendum under Article 7 of the Town Law, and BE IT FURTHER

RESOLVED, that the Town Clerk be and hereby is directed to publish the attached

Notice of Adoption of Resolution Subject to Permissive Referendum in the Cheektowaga Bee.

**NOTICE OF ADOPTION OF RESOLUTION
SUBJECT TO PERMISSIVE REFERENDUM**

NOTICE IS HEREBY GIVEN, that the Town Board of the Town of Cheektowaga, on November 3, 2014, adopted a resolution authorizing the Town of Cheektowaga to discontinue and convey the following described portion of a Town highway known as McKesson Parkway to PCO Buffalo III, LLC Inc. for \$100,000.00:

ALL THAT TRACT OR PARCEL OF LAND situate in the Town of Cheektowaga, County of Erie and State of New York, being part of Lot 16, Township 11, range 7 of the Holland land Company's Survey and also being a portion of property conveyed to the Town of Cheektowaga by deeds recorded in the Erie County Clerk's Office in Liber 7380 of Deeds at page 421 and Liber 8149 of Deeds at page 61, further bounded and described as follows:

BEGINNING at an angle point in the northerly line of lands conveyed to the Town of Cheektowaga by deed recorded in the Erie County Clerk's Office in Liber 7380 of Deeds at page 421 at the division line of lands of W.W. Grainger, Inc. on the east and PCO Buffalo III, LLC on the west;

Thence through the lands so conveyed to the Town of Cheektowaga the following six (6) courses and distances:

- 1) S 00°34'30" W, a distance of 71.98 feet;
- 2) S 82°01'32" W, a distance of 121.71 feet;
- 3) S 87°57'09" W, a distance of 87.90 feet;
- 4) N 85°13'49" W, a distance of 121.85 feet;
- 5) N 82°58'14" W, a distance of 186.37 feet;
- 6) N 79°47'47" W, a distance of 86.05 feet to the west line of said lands conveyed to the Town of Cheektowaga;

Thence along the boundary line of lands conveyed to the Town of Cheektowaga, the following three (3) courses and distances:

- 1) N 00°34'30" E, a distance of 136.29 feet;
- 2) S 89°25'30" E, a distance of 50.00 feet;
- 3) S 80°29'12" E, a distance of 556.47 feet to the point or place of beginning, containing 1.733 acres of land, more or less.

A copy of such resolution and proposed deed are on file in the Town Clerk's Office where the same may be viewed during regular business hours.

TAKE FURTHER NOTICE, that such resolution is subject to permissive referendum under Article 7 of the Town Law of the State of New York.

BY ORDER OF THE TOWN BOARD OF THE TOWN OF CHEEKTOWAGA, ERIE COUNTY, NEW YORK

DATED: November 3, 2014

ALICE MAGIERSKI
Town Clerk

RESULT:	ADOPTED [UNANIMOUS]
MOVER:	Gerald Kaminski, Councilmember
SECONDER:	Mary Holtz, Supervisor
AYES:	Holtz, Rogowski, Kaminski, Wozniak, Benczkowski, Meyers



9. RESOLUTION 2014-595

Resolution and Order Extending the Boundaries of Cleveland Hill Fire District No. 6

Sponsored By: Councilmember Rogowski, Councilmember Meyers

WHEREAS, the Town Board of the Town of Cheektowaga, in the County of Erie, deems it advisable that Cleveland Hill Fire District No., 6 of said Town be extended to include the territory described as follows:

ALL THAT TRACT OR PARCEL OF LAND situate in the Town of Cheektowaga, County of Erie, State of New York being part of Lots 35 and 36, Township 11, Range 7 of the Holland Land Company's survey, more particularly bounded and described as follows:

BEGINNING at a point at the centerline intersection of Pine Ridge Road and Sugar Road;

THENCE northerly along the centerline of Pine Ridge Road and continuing northerly along the centerline extension of said Pine Ridge Road, a distance of 1280 feet, more or less, to the southerly line of lands now or formerly designated as G. F. Rooke as designated and marked on Plate, or Page 14 on the 1909 New Century Atlas of Erie County;

THENCE westerly along the southerly line of lands designated in said Atlas on said Page as G. F. Rooke, 830 feet, more or less to the southeasterly corner of lands so designated in said Atlas on said Page as W. Hayes;

THENCE northerly along the easterly boundary of lands so designated in said Atlas on said Page as W. Hayes and continuing northerly along the easterly line of lands designated in said Atlas on said Page as Land Co. a total distance of 2500 feet, more or less, to a point in the south line of Map Cover 1695;

THENCE easterly, 227.90 feet, more or less along the south line of Map Cover 1695, to the southeast corner of Map Cover 1695;

THENCE northerly, 109 feet, more or less, along the east line of Map Cover 1695 to the south line of Map cover 1726 and also the south line of lands now or formerly owned by one Knoche as designated in said Atlas on said Page as W. Knoche 55 1-2A;

THENCE easterly along the southerly line of said lands of Knoche, and Map Cover 1726, 1822 feet, more or less to the centerline of Harlem Road;

Thence southerly along the centerline of Harlem Road, 3032 feet more or less, to the centerline of Maryvale drive;

Thence easterly along the centerline of Maryvale Drive to the east line of Harlem Road;

Thence southerly along the easterly line of Harlem Road, 1018.7 feet, more or less, to the northwest corner of lands now or formerly of 3095 Harlem Road, Inc.

THENCE easterly along the northerly line of said lands of 3095 Harlem Road, Inc., 1000 feet (record) to the northeasterly corner of said lands now or formerly of MRP Development Group, LLC.;

THENCE southerly parallel with the easterly line of Harlem Road and along the easterly line of said lands of MRP Development Group, LLC., 876.48 feet (record) to the southeasterly corner thereof and at a point on the northerly line of lands of the Holy Sepulchre Cemetery as recorded in the Erie County Clerk's Office in Liber 1281 of deeds at page 19;

THENCE westerly parallel with the southerly line of Lot 26 and along the northerly line of said lands of the Holy Sepulchre Cemetery, a distance of 401.62 feet (record);

THENCE northerly along a line at an interior angle of $90^{\circ}12'12''$ with the last described course, a distance of 95.11 feet (record) to a point;

THENCE northwesterly along a line at an interior angle of $201^{\circ}47'27''$ with the last described course, a distance of 97.15 feet (record) to a point;

THENCE northwesterly along a line at an interior angle of $163^{\circ}27'36''$ with the last described course, a distance of 90.87 feet (record) to a point;

THENCE northeasterly along a line at an interior angle of $90^{\circ}01'55''$ with the last described course, a distance of 22.42 feet (record) to a point;

THENCE northwesterly at right angles, a distance of 43.83 feet (record) to a point;

THENCE northeasterly along a line at an interior angle of $129^{\circ}30'50''$ with the last described course, a distance of 37.89 feet (record) to a point;

THENCE northwesterly at right angles, a distance of 71.00 feet (record) to a point;

THENCE northeasterly at right angles, a distance of 169.64 feet (record) to a point;

THENCE northwesterly at right angles, a distance of 324.00 feet (record) to a point;

THENCE southwesterly at right angles, a distance of 62.00 feet (record) to a point;

THENCE northwesterly at right angles, a distance of 20.00 feet (record) to a point;

THENCE southwesterly at right angles, a distance of 24.00 feet to (record) a point;

THENCE northwesterly at right angles, a distance of 38.00 feet (record) to a point;

THENCE southwesterly at right angles, a distance of 178.52 feet (record) to a point;

THENCE westerly along a line being the southerly line of lands conveyed to 3095 Harlem Road, Inc., as recorded in the Erie County Clerk's Office in Liber 10929 of deeds at page 2998 and the easterly extension thereof, at an interior angle of $135^{\circ}00'00''$, a distance of 236.73 feet, more or less, to a point in the centerline of Harlem Road;

THENCE northerly along said centerline of Harlem Road, a distance of 187 feet, more or less, to the northeast corner of lands now or formerly of Mount Calvary Cemetery;

THENCE westerly along a the northerly boundary line of said Mount Calvary Cemetery lands, a distance of 1450 feet, more or less, to the point or place of beginning.

, and

WHEREAS, said Town Board duly adopted on the 6th day of October, 2014, a resolution providing that said Town Board shall meet at the Town Hall, 3301 Broadway, Cheektowaga, New York on the 20th day of October, 2014 at 6:45 P.M., to hear all persons interested in the matter of the extension of such Fire District, and notice of such hearing was duly published and posted as prescribed by law, and said Town Board has, at the time and place specified in said notice, duly met and considered the matter of such extension and heard all persons interested in the subject thereof who appeared at such time and place, concerning the same, and

WHEREAS, the evidence offered at such time and place requires that the Town Board make the determination hereinafter made,

NOW, THEREFORE, BE IT RESOLVED, by the Town Board of the Town of Cheektowaga, in the County of Erie, that it be and hereby is determined as follows:

- (1) That all of the property and property owners within the proposed extension of said Fire District are benefited thereby.
- (2) That all of the property and property owners benefited are included within the proposed extension of said Fire District.
- (3) It is in the public interest to extend the existing Cleveland Hill Fire District No. 6 of said Town to include the territory hereinbefore described

, and BE IT

FURTHER RESOLVED, that the Town Clerk be and hereby is authorized and directed to file a certified copy of this resolution, in the Erie County Clerk's Office, and BE IT

FURTHER RESOLVED, that the Town Clerk shall, within ten (10) days after adoption of this resolution, file a certified copy of this resolution in the office of the State Department of Audit and Control.

RESULT:	ADOPTED [UNANIMOUS]
MOVER:	James P. Rogowski, Councilmember
SECONDER:	Timothy J. Meyers, Councilmember
AYES:	Holtz, Rogowski, Kaminski, Wozniak, Benczkowski, Meyers



10. RESOLUTION 2014-596

Resolution and Order Extending the Boundaries of Pine Hill Fire District No. 5

Sponsored By: Councilmember Rogowski, Councilmember Meyers

WHEREAS, the Town Board of the Town of Cheektowaga, in the County of Erie, deems it advisable that Pine Hill Fire District No. 5 of said Town be extended to include the territory described as follows:

ALL THAT TRACT OR PARCEL OF LAND situate in the Town of Cheektowaga, County of Erie, State of New York being part of Lots 25, 26 34 and 35, Township 11, Range 7 of the Holland Land Company's survey, more particularly bounded and described as follows:

BEGINNING at a point at the centerline intersection of Pine Ridge Road and Sugar Road;
THENCE easterly along the northerly boundary line of lands now or formerly of Mount Calvary Cemetery lands, a distance of 1450 feet, more or less, to the centerline of Harlem Road;
THENCE southerly along the centerline of Harlem Road, 187 feet, more or less, to the northwest corner of lands of HR Development Group, LLC.;
THENCE easterly along a line being the southerly line of lands conveyed to 3095 Harlem Road, Inc., as recorded in the Erie County Clerk's Office in Liber 10929 of deeds at page 2998, a distance of 236.73 feet, more or less, to a point;
THENCE northeasterly along a line at an exterior angle of 135°00'00" with the last described course, a distance of 178.52 feet (record) to a point;
THENCE southeasterly at right angles, a distance of 38.00 feet (record) to a point;
THENCE northeasterly at right angles, a distance of 24.00 feet (record) to a point;
THENCE southeasterly at right angles, a distance of 20.00 feet (record) to a point;
THENCE northeasterly at right angles, a distance of 62.00 feet (record) to a point;
THENCE southeasterly at right angles, a distance of 324.00 feet (record) to a point;
THENCE southwesterly at right angles, a distance of 169.64 feet (record) to a point;
THENCE southeasterly at right angles, a distance of 71.00 feet (record) to a point;
THENCE southwesterly at right angles, a distance of 37.89 feet (record) to a point;
THENCE southeasterly along a line at an exterior angle of 129°30'50" with the last described course, a distance of 43.83 feet (record) to a point;
THENCE southwesterly at right angles, a distance of 22.42 feet (record) to a point;
THENCE southeasterly along a line at an exterior angle of 90°01'55" with the last described course, a distance of 90.87 feet (record) to a point;

THENCE southeasterly along a line at an exterior angle of 163°27'36" with the last described course, a distance of 97.15 feet (record) to a point;

THENCE southerly along a line at an exterior angle of 201°47'27" with the last described course, a distance of 95.11 feet (record) to a point on the northerly line of lands of the Holy Sepulchre Cemetery as recorded in the Erie County Clerk's Office in Liber 1281 of deeds at page 19;

THENCE easterly along the northerly line of said Holy Sepulchre Cemetery, a distance of 2614.4 feet, more or less, to the northeast corner of said Holy Sepulchre Cemetery;

THENCE southerly along the easterly line of lands of said Holy Sepulchre Cemetery and the easterly line of lands of the Diocese of Buffalo as recorded in the Erie County Clerk's Office in Liber 9276 of deeds at page 244, a distance of 558.60 feet (record), more or less, to the southeast corner of the lands of said Diocese of Buffalo and also to a point on the north line of Map Cover 1266;

THENCE westerly along the northerly line of Map Cover 1266, a distance of 1167 feet, more or less, to the northwest corner of said Map Cover 1266;

THENCE southerly along the west line of said Map Cover 1266, a distance of 558.36 feet (record) to a point in the northerly line of Lot 25, said point also being on the northerly line of Map Cover 1317;

THENCE westerly along the north line of said Map Cover 1317 and also being the north line of Lot 25, a distance of 526 feet, more or less to the northwest corner of said Map Cover 1317;

THENCE southerly along the west line of said Map Cover 1317, a distance of 315.35 feet (record), to a point in the centerline of Genesee Street;

THENCE southwesterly along the centerline of Genesee Street, a distance of 4,300 feet more or less, to the centerline intersection point of Pine Ridge Road and Genesee Street;

THENCE northeasterly along the centerline of Pine Ridge Road, a distance of 3750 feet, more or less, to the point or place of beginning.

, and

WHEREAS, said Town Board duly adopted on the 6th day of October, 2014, a resolution providing that said Town Board shall meet at the Town Hall, 3301 Broadway, Cheektowaga, New York on the 20th day of October, 2014 at 6:45 P.M., to hear all persons interested in the matter of the extension of such Fire District, and notice of such hearing was duly published and posted as prescribed by law, and said Town Board has, at the time and place specified in said notice, duly met and considered the matter of such extension and heard all persons interested in the subject thereof who appeared at such time and place, concerning the same, and

WHEREAS, the evidence offered at such time and place requires that the Town Board make the determination hereinafter made,

NOW, THEREFORE, BE IT RESOLVED, by the Town Board of the Town of

Cheektowaga, in the County of Erie, that it be and hereby is determined as follows:

- (1) That all of the property and property owners within the proposed extension of said Fire District are benefited thereby.
- (2) That all of the property and property owners benefited are included within the proposed extension of said Fire District.
- (3) It is in the public interest to extend the existing Pine Hill Fire District No. 5 of said Town to include the territory hereinbefore described

, and BE IT

FURTHER RESOLVED, that the Town Clerk be and hereby is authorized and directed to file a certified copy of this resolution, in the Erie County Clerk's Office, and BE IT

FURTHER RESOLVED, that the Town Clerk shall, within ten (10) days after adoption of this resolution, file a certified copy of this resolution in the office of the State Department of Audit and Control.

RESULT:	ADOPTED [UNANIMOUS]
MOVER:	James P. Rogowski, Councilmember
SECONDER:	Timothy J. Meyers, Councilmember
AYES:	Holtz, Rogowski, Kaminski, Wozniak, Benczkowski, Meyers



11. RESOLUTION 2014-597

Accept Sidewalk Easement at 862 Losson Road

Sponsored By: Councilmember Kaminski, Supervisor Holtz

WHEREAS, as part of the review process for the development of property located at 862 Losson Road, the owners were requested to convey a sidewalk easement to the Town of Cheektowaga over the area where the public sidewalk was constructed, and

WHEREAS, John M. Lauer and Catherine M. Lauer, the owners of such property, have submitted the requested easement to the Town, and

WHEREAS, the Building Inspections Department and Town Attorney's Office have reviewed such easement document and have recommended that the Town accept same, NOW, THEREFORE, BE IT

RESOLVED, that the aforementioned easement be and hereby is accepted by the Town, and BE IT FURTHER

RESOLVED, that the Town Attorney's Office be and hereby is directed to file such easement in the Erie County Clerk's Office.

RESULT:	ADOPTED [UNANIMOUS]
MOVER:	Gerald Kaminski, Councilmember
SECONDER:	Mary Holtz, Supervisor
AYES:	Holtz, Rogowski, Kaminski, Wozniak, Benczkowski, Meyers



12. RESOLUTION 2014-598

Accept Sidewalk Easement at 868 Losson Road

Sponsored By: Councilmember Kaminski, Supervisor Holtz

WHEREAS, as part of the review process for the development of property located at 868 Losson Road, the owners were requested to convey a sidewalk easement to the Town of Cheektowaga over the area where the public sidewalk was constructed, and

WHEREAS, John J. Lauer and Marion C. Lauer, the owners of such property, have submitted the requested easement to the Town, and

WHEREAS, the Building Inspections Department and Town Attorney's Office have reviewed such easement document and have recommended that the Town accept same, NOW, THEREFORE, BE IT

RESOLVED, that the aforementioned easement be and hereby is accepted by the Town, and BE IT FURTHER

RESOLVED, that the Town Attorney's Office be and hereby is directed to file such easement in the Erie County Clerk's Office.

RESULT:	ADOPTED [UNANIMOUS]
MOVER:	Gerald Kaminski, Councilmember
SECONDER:	Mary Holtz, Supervisor
AYES:	Holtz, Rogowski, Kaminski, Wozniak, Benczkowski, Meyers



13. RESOLUTION 2014-599

Authorize Supervisor to Execute Agreement with National Grid to Attach Holiday Decorations to Electrical Poles

Sponsored By: Councilmember Wozniak, Councilmember Rogowski

WHEREAS, during the holiday season, the Town of Cheektowaga usually attaches decorations to electrical poles throughout the town; and

WHEREAS, National Grid is the owner of electrical poles in a portion of the Town of Cheektowaga; and

WHEREAS, National Grid has notified the Town of Cheektowaga that, if we decide to attach decorations to National Grid's poles, the Town needs to execute an agreement with National Grid; and

WHEREAS, the Town is interested in attaching holiday decorations to National Grid's electrical poles; NOW, THEREFORE, BE IT

RESOLVED, that subject to approval by the Town Attorney, the Supervisor be and hereby is authorized and directed to execute an agreement with National Grid and any other documents necessary to permit the Town to attach holiday decorations to the electrical poles of National Grid.

RESULT:	ADOPTED [UNANIMOUS]
MOVER:	Angela M. Wozniak, Councilmember
SECONDER:	James P. Rogowski, Councilmember
AYES:	Holtz, Rogowski, Kaminski, Wozniak, Benczkowski, Meyers



14. RESOLUTION 2014-600

Authorize Supervisor to Sign Contracts for Concerts and Special Events for 2015

Sponsored By: Councilmember Rogowski, Supervisor Holtz

BE IT RESOLVED that subject to approval by the Town Attorney, Supervisor Mary F. Holtz be and hereby is authorized to sign contracts between the Town of Cheektowaga, performers, sponsors and recurring vendors for concerts and special events to be held during the year 2015.

FUNDING SOURCE:

0100-7140-4503

0100-7140-4491

0100-7620-4491

0100-7620-4685

0100-7550-4374

RESULT:	ADOPTED [UNANIMOUS]
MOVER:	James P. Rogowski, Councilmember
SECONDER:	Mary Holtz, Supervisor
AYES:	Holtz, Rogowski, Kaminski, Wozniak, Benczkowski, Meyers



15. RESOLUTION 2014-601

Request Erie County to Levy Omitted Taxes Against Properties in the Town

Sponsored By: Councilmember Benczkowski, Supervisor Holtz

WHEREAS, in any given year, when the owners of properties fail or refuse to maintain their properties, the Town of Cheektowaga must maintain or demolish the properties, and

WHEREAS, if the owners of these properties refuse to reimburse the Town for expenses incurred by the Town for the maintenance or demolition of said properties, the Town must place special assessments against these properties, and

WHEREAS, pursuant to the Town Law of the State of New York, the Town must notify the County of Erie of these special assessments which are considered omitted taxes under the law, and

WHEREAS, in 2014, the Town maintained and demolished various properties in the Town, and the expenses for same were not paid by the respective property owners, NOW, THEREFORE, BE IT

RESOLVED, that this Town Board hereby requests the Erie County Legislature to levy the sum of \$618,500.76 against the applicable properties, and BE IT FURTHER

RESOLVED, that the Assessor is hereby directed to deliver to the County of Erie her master computer assessment roll file, and BE IT FURTHER

RESOLVED, that the Town Supervisor be and hereby is authorized and directed to execute a Letter of Authorization to the Erie County Real Property Tax Department to enforce the various unpaid accounts/omitted taxes mentioned above.

RESULT:	ADOPTED [UNANIMOUS]
MOVER:	Diane Benczkowski, Councilmember
SECONDER:	Mary Holtz, Supervisor
AYES:	Holtz, Rogowski, Kaminski, Wozniak, Benczkowski, Meyers



16. RESOLUTION 2014-602

Unsafe-Unsecured/15 Hedwig Avenue

Sponsored By: Supervisor Holtz, Councilmember Benczkowski

WHEREAS, Town of Cheektowaga Law for the Administration and Enforcement of the Codes of New York State; and the Property Maintenance Code of New York State require that all vacant structures and premises shall be maintained in clean, safe, secure and sanitary conditions so as not to cause a blighting problem or adversely affect the public health or safety and all nuisances abated, AND

WHEREAS, the Town of Cheektowaga has received notification of an unsafe structure and premises located at 15 Hedwig Avenue, Cheektowaga, New York SBL# 102.53-3-21 that is a danger to the safety of others, and records kept by the Assessors Office identify Robert J. Clifford, 15 Hedwig Avenue, Cheektowaga, New York 14211, as the owner AND

WHEREAS, an inspection of such premises was conducted at 15 Hedwig Avenue, by the Housing and Neighborhood Preservation Office, AND

WHEREAS, such inspection found the premises to be deteriorated, vacant, a hazard, and a danger to the safety and well being of others, AND

WHEREAS, the Town of Cheektowaga Housing and Neighborhood Preservation Office properly notified the property owner in accordance with the Town of Cheektowaga Law for the Administration and Enforcement of the Codes of New York State, and the owner failed to take actions to safeguard the premises, AND

WHEREAS, these conditions require the Town of Cheektowaga Housing and Neighborhood Preservation Office to take immediate steps to safeguard the premises to protect the health and safety of others and abate all nuisances, NOW, THEREFORE BE IT

RESOLVED, that pursuant to Section 70-7A.(5) and Section 70-8 of the Town of Cheektowaga Law for the Administration and Enforcement of the Codes of New York State that the vacant structure premises be safeguarded and all nuisances abated; and all costs incurred be assessed against the property hereinbefore described.

RESULT:	ADOPTED [UNANIMOUS]
MOVER:	Mary Holtz, Supervisor
SECONDER:	Diane Benczkowski, Councilmember
AYES:	Holtz, Rogowski, Kaminski, Wozniak, Benczkowski, Meyers



17. RESOLUTION 2014-603

Unsafe-Unsecured/621 Mount Vernon Road

Sponsored By: Supervisor Holtz, Councilmember Benczkowski

WHEREAS, Town of Cheektowaga Law for the Administration and Enforcement of the Codes of New York State; and the Property Maintenance Code of New York State require that all vacant structures and premises shall be maintained in clean, safe, secure and sanitary conditions so as not to cause a blighting problem or adversely affect the public health or safety and all nuisances abated, AND

WHEREAS, the Town of Cheektowaga has received notification of an unsafe structure and premises located at 621 Mount Vernon Road, Cheektowaga, New York SBL# 80.69-4-3 That is a danger to the safety of others, and records kept by the Assessors Office identify David A. Holdsworth, 621 Mount Vernon Road, Cheektowaga, New York 14215, as the owner AND

WHEREAS, an inspection of such premises was conducted at 621 Mount Vernon Road, by the Housing and Neighborhood Preservation Office, AND

WHEREAS, such inspection found the premises to be deteriorated, vacant, a hazard, and a danger to the safety and well being of others, AND

WHEREAS, the Town of Cheektowaga Housing and Neighborhood Preservation Office properly notified the property owner in accordance with the Town of Cheektowaga Law for the Administration and Enforcement of the Codes of New York State, and the owner failed to take actions to safeguard the premises, AND

WHEREAS, these conditions require the Town of Cheektowaga Housing and Neighborhood Preservation Office to take immediate steps to safeguard the premises to protect the health and safety of others and abate all nuisances, NOW, THEREFORE BE IT

RESOLVED, that pursuant to Section 70-7A.(5) and Section 70-8 of the Town of Cheektowaga Law for the Administration and Enforcement of the Codes of New York State that the vacant structure premises be safeguarded and all nuisances abated; and all costs incurred be assessed against the property hereinbefore described.

RESULT:	ADOPTED [UNANIMOUS]
MOVER:	Mary Holtz, Supervisor
SECONDER:	Diane Benczkowski, Councilmember
AYES:	Holtz, Rogowski, Kaminski, Wozniak, Benczkowski, Meyers



18. RESOLUTION 2014-604

Unsafe-Unsecured/4-6 Redwood Drive

Sponsored By: Supervisor Holtz, Councilmember Benczkowski

WHEREAS, Town of Cheektowaga Law for the Administration and Enforcement of the Codes of New York State; and the Property Maintenance Code of New York State require that all vacant structures and premises shall be maintained in clean, safe, secure and sanitary conditions so as not to cause a blighting problem or adversely affect the public health or safety and all nuisances abated, AND

WHEREAS, the Town of Cheektowaga has received notification of an unsafe structure and premises located at 4-6 Redwood Drive, Cheektowaga, New York SBL# 91.14-10-12 That is a danger to the safety of others, and records kept by the Assessors Office identify Joan M. Garrett, 4 Redwood Drive, Cheektowaga, New York 14225, as the owner AND

WHEREAS, an inspection of such premises was conducted at 4-6 Redwood Drive, by the Housing and Neighborhood Preservation Office, AND

WHEREAS, such inspection found the premises to be deteriorated, vacant, a hazard, and a danger to the safety and well being of others, AND

WHEREAS, the Town of Cheektowaga Housing and Neighborhood Preservation Office properly notified the property owner in accordance with the Town of Cheektowaga Law for the Administration and Enforcement of the Codes of New York State, and the owner failed to take actions to safeguard the premises, AND

WHEREAS, these conditions require the Town of Cheektowaga Housing and Neighborhood Preservation Office to take immediate steps to safeguard the premises to protect the health and safety of others and abate all nuisances, NOW, THEREFORE BE IT

RESOLVED, that pursuant to Section 70-7A.(5) and Section 70-8 of the Town of Cheektowaga Law for the Administration and Enforcement of the Codes of New York State that the vacant structure premises be safeguarded and all nuisances abated; and all costs incurred be assessed against the property hereinbefore described.

RESULT:	ADOPTED [UNANIMOUS]
MOVER:	Mary Holtz, Supervisor
SECONDER:	Diane Benczkowski, Councilmember
AYES:	Holtz, Rogowski, Kaminski, Wozniak, Benczkowski, Meyers



19. RESOLUTION 2014-605

Youth & Recreation Hiring

Sponsored By: Councilmember Wozniak, Councilmember Rogowski

BE IT RESOLVED that the individuals listed below be and hereby are hired in the Department of Youth & Recreational Services effective as indicated (rate adjusted):

Recreation Attendant - 7310.1803 - Regular Part-time - \$8.15 - Retro to 10/20/14

Tracey Marlinski

14227

Motion by Councilmember Rogowski; Seconded by Councilmember Benczkowski to waive the reading of names for the following three (3) resolutions: 2014-605; 2014-606 and 2014-607. Motion Carried.

RESULT: **ADOPTED [UNANIMOUS]**

MOVER: Angela M. Wozniak, Councilmember

SECONDER: James P. Rogowski, Councilmember

AYES: Holtz, Rogowski, Kaminski, Wozniak, Benczkowski, Meyers



20. RESOLUTION 2014-606

Youth & Recreation Termination

Sponsored By: Councilmember Wozniak, Councilmember Rogowski

BE IT RESOLVED that the individuals listed below be and hereby are terminated in the Department of Youth & Recreational Services effective as indicated:

Caitlyn Ferber	8/26/13	14225 (Date Amended)
Alysia Kent	5/10/14	14225
Michele Radlich	9/19/14	14225
Alexis Wayne	Never worked	14227 (Date Amended)

RESULT:	ADOPTED [UNANIMOUS]
MOVER:	Angela M. Wozniak, Councilmember
SECONDER:	James P. Rogowski, Councilmember
AYES:	Holtz, Rogowski, Kaminski, Wozniak, Benczkowski, Meyers



21. RESOLUTION 2014-607

Hiring/Termination of Part-Time/Seasonal Employees

Sponsored By: Councilmember Kaminski, Supervisor Holtz

BE IT RESOLVED, that the following individual be and hereby is hired as a **PART-TIME EMPLOYEE** in the department listed, not to exceed nineteen (19) hours on a weekly basis, in compliance with Civil Service Laws and Regulations as well as the provisions of the Town's collective bargaining agreement between the Town of Cheektowaga and the Town of Cheektowaga Employees Association:

FACILITIES DEPARTMENT (Building & Grounds Division) Laborer \$9.00/hour effective 11/4/14
Dennis L. Williams, Cheektowaga, New York

BE IT RESOLVED, that the following seasonal and/or part-time employees be and hereby are terminated as listed:

SEWER MAINTENANCE

Christopher D. Gentile effective 10/22/14
Sean F. Ross effective 10/6/14

SANITATION DEPARTMENT

Darryl J. Dunkowski effective 9/19/14
Marc P. Beang effective 9/20/14
William C. J. Merritt effective 9/20/14
Michael A. Aiken effective 10/11/14
Sharrone M. Johnson effective 10/18/14
Keith M. Pignatora effective 9/20/14
Nicholas M. Snyder effective 9/20/14
Allen Steltermann effective 9/20/14
Walter W. Szafraniec effective 9/20/14

MAIN PUMP STATION

Samuel W. Wodowski effective 10/25/14

BE IT RESOLVED, that the following employee's status be changed:

SANITATION DEPARTMENT Laborer (Seasonal to Part Time) \$9.25/hour
Tyler D. Schaf effective 10/18/14; AND,

BE IT FURTHER RESOLVED, that the following be amended:

Termination

FACILITIES DEPARTMENT

Kyle J. Lacki to Kyle J. Lackie effective 8/18/14

RESULT:	ADOPTED [UNANIMOUS]
MOVER:	Gerald Kaminski, Councilmember
SECONDER:	Mary Holtz, Supervisor
AYES:	Holtz, Rogowski, Kaminski, Wozniak, Benczkowski, Meyers



22. RESOLUTION 2014-608

Travel Authorization Police Department/Lieutenant Brian Gould and Police Officer Timothy Turnbull

Sponsored By: Councilmember Benczkowski, Councilmember Kaminski

WHEREAS, the Project AWARE Youth Mental Health First Aid Train the Trainer Program is being held November 17 through November 21, 2014 in Pittsburgh, Pennsylvania; AND

WHEREAS, Lieutenant Brian Gould and Police Officer Timothy Turnbull have been recommended to attend said program; AND

WHEREAS, Police Chief David Zack has submitted a request for travel authorization along with the proper paperwork in a timely manner; AND

WHEREAS, no cost shall be incurred by the Town as this program is being paid for through a grant through the Cheektowaga Central School District; NOW, THEREFORE, BE IT

RESOLVED, that Lieutenant Brian Gould and Police Officer Timothy Turnbull be and hereby are authorized to attend the Project AWARE Youth Mental Health First Aid Train the Trainer Program being held November 17 through November 21, 2014 in Pittsburgh, Pennsylvania.

RESULT:	ADOPTED [UNANIMOUS]
MOVER:	Diane Benczkowski, Councilmember
SECONDER:	Gerald Kaminski, Councilmember
AYES:	Holtz, Rogowski, Kaminski, Wozniak, Benczkowski, Meyers

IV. Suspension of Rules

Motion by Councilmember Rogowski; Seconded by Council Meyers to waive the Rules to Include the Following Two (2) Resolutions. Motion Carried.



1. RESOLUTION 2014-609

Accept Proposal of Jensen BRV Engineering, PLLC for Professional Services at the Firing Range Shelter

Sponsored By: Councilmember Benczkowski, Councilmember Kaminski

WHEREAS, the contract to construct the Firing Range Shelter located on Scott Place was awarded by Town Board Resolution dated September 15, 2014, AND

WHEREAS, additional professional services are required to review structural steel fabrication drawings, foundation design and review of special inspection reports, reinforcing steel and concrete mix design, as further described in the proposal from Jensen BRV Engineering, PLLC, AND

WHEREAS, the engineering firm of Jensen BRV Engineering, PLLC has submitted a not to exceed proposal of \$3,000.00 to perform said tasks as deemed necessary by New York State Code, NOW, THEREFORE, BE IT

RESOLVED, that the firm of Jensen BRV Engineering, PLLC, 1653 East Main Street, Rochester, New York 14609 be retained for the provision of professional services in accordance with the proposal dated October 31, 2014, AND, BE IT FURTHER

RESOLVED, that the Supervisor, on behalf of this Town Board, is hereby directed and authorized to sign said agreement with Jensen BRV Engineering, PLLC on behalf of this Town Board, AND, BE IT FURTHER

RESOLVED, that the cost of said professional services in an amount not to exceed \$3,000.00 shall be chargeable to Account #500-1440-2063-5227.

RESULT:	ADOPTED [UNANIMOUS]
MOVER:	Diane Benczkowski, Councilmember
SECONDER:	Gerald Kaminski, Councilmember
AYES:	Holtz, Rogowski, Kaminski, Wozniak, Benczkowski, Meyers



2. RESOLUTION 2014-610

Accept Proposal of DiDonato Associates, P.E., P.C. for Traffic Signal Improvements

Sponsored By: Supervisor Holtz, Councilmember Meyers

WHEREAS, the Town Engineer, Deputy Highway Superintendent and Town Traffic Signal Maintenance Division have recommended that five (5) traffic signals located at:

- (1) Dingens Street @ Rossler Avenue (Stanley Falk School)
- (2) Dingens Street @ Alaska Street (Town Pool)
- (3) George Urban Boulevard @ Rosewood Terrace (near Mary Queen of Angels School)
- (4) Maryvale Drive at Maryvale School Access Road
- (5) Cleveland Drive @ Cleve-Hill Fire Hall

be upgraded to meet current standards, AND

WHEREAS, it is necessary to prepare plans, specifications and bid documents to proceed with said traffic signal improvements at the aforesaid intersections, NOW, THEREFORE, BE IT

RESOLVED, that the proposal of DiDonato Associates, P.E., P.C. dated October 9, 2014 as submitted to the Town Engineer for professional services for the preparation of plans, specifications and bid documents and construction services related to the traffic signal improvements at the aforesaid intersections is accepted and approved, AND, BE IT FURTHER

RESOLVED, that the Supervisor, on behalf of this Town Board, is hereby directed and authorized to sign the agreement with DiDonato Associates, P.E., P.C. for the provision of said professional services, AND, BE IT FURTHER

RESOLVED, that the cost of said professional services in an amount not to exceed \$67,700.00 shall be chargeable to a Capital Account designated by the Director of Finance.

RESULT:	ADOPTED [UNANIMOUS]
MOVER:	Mary Holtz, Supervisor
SECONDER:	Timothy J. Meyers, Councilmember
AYES:	Holtz, Rogowski, Kaminski, Wozniak, Benczkowski, Meyers

V. Communications

A. Departmental Communications

1. Supervisor's Statement of Funds - September 2014
2. Minutes: Cheektowaga Planning Board - October 9, 2014
3. Minutes: Cheektowaga Conservation Advisory Council - October 2, 2014
4. Minutes: Cheektowaga Traffic Safety Commission - July 15, 2014
5. Minutes: Cheektowaga Traffic Safety Commission - September 16, 2014

B. General Communications

1. Notice of Claim: Mohammad Abid vs. Town of Cheektowaga
2. Notice of Claim: Mohammad Alim, as Administrator of the Estate of Mujtoba Rafid vs. Town of Cheektowaga
3. Notice of Claim: Daniel Kaplan vs. Town of Cheektowaga
4. Notice of Claim: Danielle Kwiatkowski vs. Town of Cheektowaga
5. Notice of Claim: Eleanore Szymczak vs. Town of Cheektowaga
6. Notice of Claim: Debra Walenka, Individually and as Parent and Natural Guardian of Isabelle Walenka vs. Town of Cheektowaga

VI. Comments

A. Supervisor's Comments

B. Councilmember's Comments

C. Public Comments

Report on 36 Barbara Place: by Attorney's Charles J. Marchese, and Johnathan Pincus for PHH Bank, owner of 36 Barbara Place, regarding status for repair in lieu of demolition, they will return for the December 1, 2014.

VII. Adjournment

Motion by Supervisor Holtz; Seconded by Councilmember Kaminski to adjourn the meeting at 7:40 PM

Alice Magierski, Town Clerk



Town of Cheektowaga

Regular Meeting

~ Minutes ~

Cheektowaga, NY 14227
<http://www.town.cheektowaga.ny.us>

Alice Magierski
716-686-3400

Monday, November 17, 2014

6:45 PM

Council Chambers

I. Call to Order

6:45 PM Meeting called to order on November 17, 2014 at Council Chambers, 3301 Broadway St, Cheektowaga, NY.

Attendee Name	Organization	Title	Status	Arrived
Mary Holtz	Town of Cheektowaga	Supervisor	Present	
James P. Rogowski	Town of Cheektowaga	Councilmember	Present	
Gerald Kaminski	Town of Cheektowaga	Councilmember	Present	
Angela M. Wozniak	Town of Cheektowaga	Councilmember	Present	
Diane Benczkowski	Town of Cheektowaga	Councilmember	Present	
Timothy J. Meyers	Town of Cheektowaga	Councilmember	Present	

2. Additional Attendees

Patrick Bowen, Town Engineer
 Ellen Fischer, Executive Director - Youth Board
 Carla A. Kosmerl, Director of Community Development
 Brian Krause, Director of Finance and Administration
 Jeneen Lomando-McSkimming, Assessor
 Karen Marchese, Coordinator of Employee Relations
 Kevin Schenk, Town Attorney

II. Public Comment Period

III. Public Hearing

1. Amend Prior Year Annual Plans for CDBG

COMMENTS - Current Meeting:

This being the time and place advertised for a Public Hearing, the Supervisor directed the Town Clerk to present that such notice has been duly published and posted; upon the order of the Supervisor such proof was duly filed.

The Supervisor announced that the Town Board would hear all persons interested in the subject of the hearing. Comments were heard, after which the Supervisor declared the hearing closed, decision was reserved.

RESULT:	CLOSED [UNANIMOUS]
MOVER:	Mary Holtz, Supervisor
SECONDER:	Diane Benczkowski, Councilmember
AYES:	Holtz, Rogowski, Kaminski, Wozniak, Benczkowski, Meyers

IV. Resolutions



1. RESOLUTION 2014-611

Transfer of Funds

Sponsored By: Councilmember Kaminski, Supervisor Holtz

BE IT RESOLVED, that the following transfer is hereby approved and made part hereof;

GENERAL

FROM: 100.1355.4575 Contracted Appraisals \$73,000.00

TO: 100.1910.4322 Contracted Appraisal-AEP \$73,000.00

SPECIAL DISTRICTS

FROM: 150.8160.4468 Compost \$3,000.00

TO: 150.8160.4211 Electric \$3,000.00

HIGHWAY

FROM: 300.1910.2665 Revenue Account \$10,050.00

TO: 300.5140.4191 Miscellaneous \$10,050.00

RESULT: **ADOPTED [UNANIMOUS]**

MOVER: Gerald Kaminski, Councilmember

SECONDER: Mary Holtz, Supervisor

AYES: Holtz, Rogowski, Kaminski, Wozniak, Benczkowski, Meyers



2. RESOLUTION 2014-612

Warrant

Sponsored By: Councilmember Kaminski, Supervisor Holtz

BE IT RESOLVED, that the following Vouchers & Warrants submitted to the Town of Cheektowaga prior to November 17, 2014 are hereby approved and made part hereof;

GENERAL FUND	\$224,592.62
RISK RETENTION FUND	64,644.62
NYS HOME PROGRAM	0.00
DEBT	0.00
HUD HOUSING REHABILITATION FUND	24,916.26
SPECIAL DISTRICTS FUND	270,050.59
HIGHWAY FUND	95,489.70
CAPITAL FUND	528,975.07
TRUST & AGENCY FUND	12,071.58
HUD CDBG FUND	3,281.41
PART TOWN FUND	16,974.05
NYS AFFORDABLE HOUSING	2,595.00
	<hr/>
	\$1,243,590.90

RESULT:	ADOPTED [UNANIMOUS]
MOVER:	Gerald Kaminski, Councilmember
SECONDER:	Mary Holtz, Supervisor
AYES:	Holtz, Rogowski, Kaminski, Wozniak, Benczkowski, Meyers



3. RESOLUTION 2014-613

Award of Bid - Two (2) 2015 Ford Focus S Sedans (Bid 2014-33)

Sponsored By: Councilmember Kaminski, Supervisor Holtz

WHEREAS, bids were received and publicly opened on November 5, 2014 for the purchase of two (2) new and unused 2014 or newer Ford Focus S 4-door compact sedans, AND

WHEREAS, said bids were referred to the Town Engineer for analysis, tabulation and report, which tabulation and report is contained in a letter from the Town Engineer dated November 6, 2014, NOW, THEREFORE, BE IT

RESOLVED, that the contract for the purchase and delivery of two (2) 2015 Ford Focus S 4-door sedans be awarded to:

Basil Ford, Inc.
1540 Walden Avenue
Cheektowaga, NY 14225

for their submission of the lowest bid meeting the requirements of the specifications in the amount of \$31,198.00, AND, BE IT FURTHER

RESOLVED, that the aforesaid purchase shall be chargeable to Account Nos. 1640-2502 and 1640-4446.

RESULT:	ADOPTED [UNANIMOUS]
MOVER:	Gerald Kaminski, Councilmember
SECONDER:	Mary Holtz, Supervisor
AYES:	Holtz, Rogowski, Kaminski, Wozniak, Benczkowski, Meyers



4. RESOLUTION 2014-614

Award of Bid - One 2015 Ford Escape SE, SUV (Bid 2014-34)

Sponsored By: Councilmember Meyers, Supervisor Holtz

WHEREAS, bids were received and publicly opened on November 5, 2014 for the purchase of one (1) new and unused 2014 or newer Ford Escape SE, SUV, AND

WHEREAS, said bids were referred to the Town Engineer for analysis, tabulation and report, which tabulation and report is contained in a letter from the Town Engineer dated November 7, 2014, NOW, THEREFORE, BE IT

RESOLVED, that the contract for the purchase and delivery of one (1) 2015 Ford Escape SE, SUV be awarded to:

Basil Ford, Inc.
1540 Walden Avenue
Cheektowaga, New York 14225

for their submission of the lowest bid meeting the requirements of the specifications in the amount of \$21,239.00, AND, BE IT FURTHER

RESOLVED, that the aforesaid purchase shall be chargeable to Account No. 255-8125-2550.

RESULT:	ADOPTED [UNANIMOUS]
MOVER:	Timothy J. Meyers, Councilmember
SECONDER:	Mary Holtz, Supervisor
AYES:	Holtz, Rogowski, Kaminski, Wozniak, Benczkowski, Meyers



5. RESOLUTION 2014-615

Award Bid - One (1) New and Unused 2015 Model Step Van Truck with an Integrated 16 Foot Aluminum Body and Dual Wheels (Bid 2014-35)

Sponsored By: Councilmember Kaminski, Supervisor Holtz

WHEREAS, a bid was received and opened by the Town Clerk at a public bid opening held on November 5, 2014, for One (1) New and Unused 2015 Model Step Van Truck with an Integrated 16 Foot Aluminum Body and Dual Wheels for use by the Town of Cheektowaga Highway Department as a result of advertisement thereof, and such bid was referred to the Superintendent of Highway for analysis, tabulation and reports, AND

Whereas, there was one sole bidder, and the bid was analyzed and completed, NOW THEREFORE BE IT

RESOLVED, the responsible bidder meeting bid specs for One (1) New and Unused 2015 Model Step Van Truck with an Integrated 16 Foot Aluminum Body and Dual Wheels be awarded to Fleet Maintenance, Inc., 67 Ransier Drive, West Seneca, NY 14224 at a total bid price of \$64,945.00 said bidder meeting specifications of bid. AND, BE IT FURTHER

RESOLVED, that the monies be charged to line 100.3310.2303.

RESULT:	ADOPTED [UNANIMOUS]
MOVER:	Gerald Kaminski, Councilmember
SECONDER:	Mary Holtz, Supervisor
AYES:	Holtz, Rogowski, Kaminski, Wozniak, Benczkowski, Meyers



6. RESOLUTION 2014-616

Negative SEQR Declaration - 2700 Union Road Express Mart

Sponsored By: Councilmember Meyers, Supervisor Holtz

WHEREAS, pursuant to the Environmental Impact Review Ordinance of the Town of Cheektowaga, the Environmental Advisory Committee ("EAC") reviews various applications for site plans, rezonings, special permits, etc. and renders its recommendation concerning the environmental significance of such application, AND

WHEREAS, an application was submitted by Carmina Wood Morris, DPC on behalf of Rerob, LLC for the rezoning of 2700 Union Road from CM- General Commercial to MS- Motor Service, for the re-development of an existing lawful non conforming gasoline station/convenience store and the construction of a new 5,256 s.f. gasoline station /convenience store with an accessory coffee shop, AND

WHEREAS, the Town Board, pursuant to the Environmental Impact Review Ordinance of the Town of Cheektowaga, is designated the Lead Agency, AND

WHEREAS, since the Town Board is the Lead Agency, it must affirm, modify or reject any recommendations submitted to it by the Advisory Committee, AND

WHEREAS, the Town of Cheektowaga Planning Board recommended approval of the rezoning and site plan/special use permit at their meetings of August 14, 2014 and October 9, 2014 respectively, AND

WHEREAS, the applicant performed a Traffic Impact Study which indicated that the proposed re-development will not contribute significantly to existing traffic levels at the intersection of William Street and Union Road, AND

WHEREAS, the applicant has modified his site plan to eliminate a proposed self operated car wash, seek permission from NYSDOT/Erie County Highway Dept. for a no left turn sign at his William Street driveway, add additional internal signage and has agreed to perform a post construction Traffic Impact Statement within six months of store opening, to confirm if any traffic mitigation may be necessary, AND

WHEREAS, the Environmental Advisory Committee at its meetings held on November 12, 2014 recommended a determination of non-significance, AND

WHEREAS, this Town Board has reviewed the application submitted and the recommendations made by the Environmental Advisory Committee and the Planning Board NOW, THEREFORE, BE IT

RESOLVED, that this Town Board determines that the project will not have a significant effect on the environment and therefore issues a Negative Declaration for purposes of the State Environmental Quality Review Act (SEQRA).

Attachments:
EAF 2700 Union Road (PDF)

RESULT:	ADOPTED [UNANIMOUS]
MOVER:	Timothy J. Meyers, Councilmember
SECONDER:	Mary Holtz, Supervisor
AYES:	Holtz, Rogowski, Kaminski, Wozniak, Benczkowski, Meyers



7. RESOLUTION 2014-617

Accept Site Plan- 2700 Union Road Express Mart

Sponsored By: Councilmember Benczkowski, Councilmember Rogowski

WHEREAS, pursuant to the Zoning Law of the Town of Cheektowaga, the Planning Board reviews various development review applications for site plans, rezonings, special permits and realty subdivisions and renders its recommendation concerning the compatibility of such application with the zoning regulations, the Town Master Plan and neighborhood character, AND

WHEREAS, the Town Board, pursuant to section 260-47.1C of the Zoning Law of the Town of Cheektowaga is vested with the authority to approve site plans and modify or reject any recommendation submitted to it by its advisory committees, AND

WHEREAS, Carmina Wood Morris, DPCon behalf of Rerob, LLC submitted a development review application for the rezoning of 2700 Union Road from CM- General Commercial to MS- Motor Service, for the re-development of an existing lawful non conforming gasoline station/convenience store and construction of a new 5,256 s.f. gasoline station convenience store with an accessory coffee shop, AND

WHEREAS, the applicant has modified his site plan by removing a proposed self operated car wash, AND

WHEREAS, the Town of Cheektowaga Planning Board, reviewed and commented on the Application at their meetings of August 14, 2014 and October 9, 2014 and have recommended approval thereof, NOW THEREFORE BE IT,

RESOLVED, that pursuant to Section 260-47-1 of the Code of the Town of Cheektowaga and Section 274-a of New York State Town Law that this Town Board approves the proposed site plan subject to:

1. The installation of a no left had turn sign, with permission of NYSDOT /Erie County Highway Department, restricting egress movements the William Street Driveway.
2. Adding additional internal signage for patrons approaching the drive thru lane from within the site.
3. The Town Engineer reviewing and approving the drainage/grading plan.
4. The Town Planner reviewing and approving a photometric plan for exterior lighting and a landscaping plan.
5. The applicant performing a post construction traffic impact study within six months of store opening.

Attachments:

final site plan no carwash 11-14-2014 (PDF)

RESULT: **ADOPTED [UNANIMOUS]**
MOVER: Diane Benczkowski, Councilmember
SECONDER: James P. Rogowski, Councilmember
AYES: Holtz, Rogowski, Kaminski, Wozniak, Benczkowski, Meyers



8. RESOLUTION 2014-618

Approve Rezoning, Special Use Permit & Variance - 2700 Union Road

Sponsored By: Councilmember Benczkowski, Councilmember Meyers

WHEREAS, Rerob, LLC has made application and requested a rezoning of 2700 Union Road from CM-General Commercial District to MS-Motor Service District, as well as a Special Use Permit for an accessory drive through window for a proposed 5,256 square convenience store with gasoline sales and an accessory coffee/donut shop pursuant to Sections 260-47 and 260-48.2 of the Code of the Town of Cheektowaga ("Zoning Law"); and

WHEREAS, Rerob, LLC also requested a variance to reduce the distance of driveway(s) which serve drive-thru lanes from the functional area of a road intersection from 220 feet to 90 feet, and

WHEREAS, a public hearing was held before the Cheektowaga Town Board on the 15th day of September, 2014 at 6:45 P.M. of said day for the purpose of considering said applications for the Rezoning and Special Permit, after publication and service of the notices required by the provisions of the Zoning Law and the Town Law; and all interested parties were given an opportunity to be heard at such hearing; and

WHEREAS, the Cheektowaga Planning Board has recommended approval of this Rezoning and Special Permit; and

WHEREAS, this Town Board previously issued a Negative Declaration under SEQRA for this project; NOW, THEREFORE BE IT

RESOLVED, that the application of Rerob, LLC for the rezoning from CM-General Commercial District to MS-Motor Services District for the property described in the attached legal description for a gasoline station and convenience store with an accessory drive thru coffee/donut shop be and hereby is approved subject to the following condition:

1. Any future additions to the development or site plan must be resubmitted to the Town Board to determine whether the addition is substantially in agreement with the intent of this rezoning and site plan approval.

, and BE IT FURTHER

RESOLVED, that the Zoning Map and Law of the Town of Cheektowaga be amended in accordance with the above, and BE IT FURTHER

RESOLVED, that the aforesaid Special Use Permit be and hereby is granted, and BE IT FURTHER

RESOLVED, that this Town Board hereby grants the aforementioned variance relating to the distance of the driveway(s) which serve the drive thru lanes from the functional area of a road intersection from 220 feet to 90 feet.

RESULT:	ADOPTED [UNANIMOUS]
MOVER:	Diane Benczkowski, Councilmember
SECONDER:	Timothy J. Meyers, Councilmember
AYES:	Holtz, Rogowski, Kaminski, Wozniak, Benczkowski, Meyers



9. RESOLUTION 2014-619

Notice of Hearing for Demolition of 169 Garland Avenue

Sponsored By: Councilmember Benczkowski, Councilmember Meyers

WHEREAS, the Supervising Code Enforcement Officer has received information that the structure(s) located at **169 Garland Avenue in the Town of Cheektowaga (S.B.L. No. 113.63-2-24)** has become dangerous and unsafe to the general public and unfit for the purposes for which it may lawfully be used; and

WHEREAS, said building has been inspected and a written report of the condition has been completed by Nussbaumer & Clarke, Inc., duly authorized agent of the Town of Cheektowaga, setting forth its findings and recommendations in regard to the repair or demolition and removal of the building, and said written report describes extensive deterioration and damage to the building and premises and recommends that the building be demolished and removed as soon as possible; and

WHEREAS, the Town Board has fully considered such written report and has determined that the building is dangerous and unsafe to the general public and unfit for the purposes for which it may lawfully be used; NOW THEREFORE BE IT

RESOLVED, that this Town Board accepts the findings and recommendations of Nussbaumer & Clarke, Inc., dated **August 18, 2014**; and BE IT FURTHER

RESOLVED, that a notice shall be served, pursuant to Section 75-7 of the Cheektowaga Town Code, upon the owner, executor, administrator, agent, lessee or any person having a vested or contingent interest in such unsafe building as shown by the records of the Receiver of Taxes or of the County Clerk, which notice shall have the contents prescribed by Section 75-6 of said Town Code, including, but not limited to a date, time and place for a hearing before the Town Board in relation to such dangerous and unsafe building, which hearing shall be scheduled not less than five business days from the date of service of the notice; and BE IT FURTHER

RESOLVED, that a hearing before this Board in relation to this dangerous and unsafe building shall be held on the **1st day of December, 2014 at 6:45 P.M.** at the Cheektowaga Town Hall, 3301 Broadway, Cheektowaga, New York, and BE IT FURTHER

RESOLVED, that the Code Enforcement Office and/or the Town Attorney's Office be and hereby are directed to serve notice of said hearing on all interested parties.

RESULT:	ADOPTED [UNANIMOUS]
MOVER:	Diane Benczkowski, Councilmember
SECONDER:	Timothy J. Meyers, Councilmember
AYES:	Holtz, Rogowski, Kaminski, Wozniak, Benczkowski, Meyers



10. RESOLUTION 2014-620

Notice of Hearing for Demolition of 274 Cherokee Drive

Sponsored By: Councilmember Benczkowski, Councilmember Meyers

WHEREAS, the Supervising Code Enforcement Officer has received information that the structure(s) located at **274 Cherokee Drive in the Town of Cheektowaga (S.B.L. No. 91.19-7-19)** has become dangerous and unsafe to the general public and unfit for the purposes for which it may lawfully be used; and

WHEREAS, said building has been inspected and a written report of the condition has been completed by Nussbaumer & Clarke, Inc., duly authorized agent of the Town of Cheektowaga, setting forth its findings and recommendations in regard to the repair or demolition and removal of the building, and said written report describes extensive deterioration and damage to the building and premises and recommends that the building be demolished and removed as soon as possible; and

WHEREAS, the Town Board has fully considered such written report and has determined that the building is dangerous and unsafe to the general public and unfit for the purposes for which it may lawfully be used; NOW THEREFORE BE IT

RESOLVED, that this Town Board accepts the findings and recommendations of Nussbaumer & Clarke, Inc., dated **July 9, 2014**; and BE IT FURTHER

RESOLVED, that a notice shall be served, pursuant to Section 75-7 of the Cheektowaga Town Code, upon the owner, executor, administrator, agent, lessee or any person having a vested or contingent interest in such unsafe building as shown by the records of the Receiver of Taxes or of the County Clerk, which notice shall have the contents prescribed by Section 75-6 of said Town Code, including, but not limited to a date, time and place for a hearing before the Town Board in relation to such dangerous and unsafe building, which hearing shall be scheduled not less than five business days from the date of service of the notice; and BE IT FURTHER

RESOLVED, that a hearing before this Board in relation to this dangerous and unsafe building shall be held on the **1st day of December, 2014 at 6:45 P.M.** at the Cheektowaga Town Hall, 3301 Broadway, Cheektowaga, New York, and BE IT FURTHER

RESOLVED, that the Code Enforcement Office and/or the Town Attorney's Office be and hereby are directed to serve notice of said hearing on all interested parties.

RESULT:	ADOPTED [UNANIMOUS]
MOVER:	Diane Benczkowski, Councilmember
SECONDER:	Timothy J. Meyers, Councilmember
AYES:	Holtz, Rogowski, Kaminski, Wozniak, Benczkowski, Meyers



11. RESOLUTION 2014-621

Establish 2015 Program Fees for Youth & Recreation

Sponsored By: Councilmember Wozniak, Councilmember Rogowski

BE IT RESOLVED that the following program fees be and hereby are established in the Department of Youth & Recreational Services:

FEEES IN (\$0.00) DENOTE 2014 FEEES

RESIDENT DISCOUNT CARDS

CHILDREN	(7 - 15 YEARS OF AGE)	\$5.00	(\$5)
ADULT	(16 - 59 YEARS OF AGE)	\$7.00	(\$7)
SENIORS	(60 YEARS OF AGE AND OLDER)	FREE	(FREE)

CAMP DARTWOOD, CAMP FLAMINGO & TEEN CLUB

SUMMER	RESIDENT	NON-RESIDENT
PER CHILD ALL 6 WEEKS	\$ 683 (\$663)	\$ 818 (\$794)
PER CHILD WEEKLY	\$ 123 (\$119)	\$ 150 (\$146)
SECOND CHILD ALL 6 WEEKS	\$ 663 (\$644)	\$ 797 (\$774)
SECOND CHILD WEEKLY	\$ 117 (\$114)	\$ 144 (\$140)
THREE (3) DAYS PER WEEK	\$ 109 (\$106)	\$118 (\$115)

YOUTH IN TRAINING

RESIDENT	NON-RESIDENT
\$197 (\$191)	\$232 (\$225)

CAMP JI-IK-DO-WAH-GAH/CAMP CRABAPPLE

SUMMER	RESIDENT	NON-RESIDENT
PER CHILD ALL 6 WEEKS	\$ 663 (\$644)	\$ 818 (\$794)
PER CHILD WEEKLY	\$ 123 (\$119)	\$ 150 (\$146)
SECOND CHILD ALL 6 WEEKS	\$ 639 (\$620)	\$ 797 (\$774)
SECOND CHILD WEEKLY	\$ 117 (\$114)	\$ 144 (\$140)
THREE (3) DAYS PER WEEK	\$ 109 (\$106)	\$118 (\$115)

ADAPTED RECREATION PROGRAM

OCTOBER - APRIL	RESIDENT	NON-RESIDENT
	\$ 250 (\$231)	\$ 280 (\$267)

SPECIAL OLYMPICS ONLY

RESIDENT	NON-RESIDENT
----------	--------------

October - May	\$40	\$40
January - May	\$32	\$32

LET'S GET REVIN WITH 5,6,7

SUMMER	RESIDENT	NON-RESIDENT
PER CHILD	\$60 (\$60)	\$65 (\$65)
SECOND CHILD	\$55 (\$55)	\$60 (\$60)

TWO, THREE AND FOUR, FUN TO EXPLORE**(Summer Fun for 2, 3's & 4's)**

SUMMER	RESIDENT	NON-RESIDENT
PER CHILD	\$55 (\$55)	\$61 (\$61)
SECOND CHILD	\$50 (\$50)	\$56 (\$56)

BREAK CLUBS

4 DAYS	RESIDENT	NON-RESIDENT
SECOND CHILD	\$112	\$124
5 DAYS	\$104	\$116
SECOND CHILD	\$140 (\$135)	\$155 (\$150)
SINGLE DAY	\$130	\$145
SECOND CHILD	\$28 (\$27)	\$31 (\$30)
	\$26	\$29

**HOME WORK HELPERS
PER HOUR**

RESIDENT	NON-RESIDENT
\$10 (\$8)	\$10 (\$8)

GIRL POWER

RESIDENT	NON-RESIDENT
\$47 (\$45)	\$57 (\$55)

I'M A PRETTY PRINCESS

RESIDENT	NON-RESIDENT
\$32	\$37

GYMNASTICS (Beginners) Fall/Winter/Spring/Summer

2 DAY (12 classes)	RESIDENT	NON-RESIDENT
PER CHILD	\$67 (\$66)	\$77 (\$76)
SECOND CHILD	\$62 (\$61)	\$72 (\$71)

SUMMER (1 DAY, 6 classes)

PER CHILD	\$35 (\$33)	\$45 (\$43)
SECOND CHILD	\$30 (\$28)	\$40 (\$38)

TINY TUMBLERS

FALL/WINTER/SPRING/SUMMER	RESIDENT	NON-RESIDENT
SECOND CHILD	\$48 (\$47)	\$58 (\$57)
	\$43 (\$42)	\$53 (\$52)

TINY TUMBLERS 16 CLASSES

PER CHILD	RESIDENT	NON-RESIDENT
SECOND CHILD	\$64	\$74
	\$59	\$69

BEGINNER GYMNASTICS 16 CLASSES	RESIDENT	NON-RESIDENT
PER CHILD	\$89	\$99
SECOND CHILD	\$84	\$94

ADVANCED I & II GYMNASTICS

SUMMER/FALL/WINTER/SPRING - 12 CLASSES	RESIDENT	NON-RESIDENT
PER CHILD	\$72 (\$70)	\$82 (\$80)
SECOND CHILD	\$67 (\$65)	\$77 (\$75)

ADVANCED I & II GYMNASTICS 16 CLASSES

	RESIDENT	NON-RESIDENT
PER CHILD	\$96	\$108
SECOND CHILD	\$91	\$103

INTRO TO ADVANCED GYMNASTICS

PER CHILD	\$72 (\$70)	\$82 (\$80)
SECOND CHILD	\$67 (\$65)	\$77 (\$75)

INTRO TO ADVANCED GYMNASTICS 16 CLASSES

PER CHILD	\$96	\$108
SECOND CHILD	\$91	\$103
OPEN WORKOUT	\$6 (\$5)	\$6 (\$5)
PRIVATE LESSON	\$12 -	\$12 -
PRIVATE LESSON (NOT REGISTERED IN GYMNASTICS CLASS)	\$15 -	\$15 -

JUST A BACK HANDSPRING & FLOOR EXERCISE & TUMBLING

	RESIDENT	NON-RESIDENT
PER CHILD	\$67 (\$66)	\$77 (\$76)
2 ND CHILD	\$62 (\$61)	\$72 (\$71)

JUST A BACK HANDSPRING & FLOOR EXERCISE & TUMBLING 16 CLASSES

	RESIDENT	NON-RESIDENT
PER CHILD	\$89	\$99
2 ND CHILD	\$84	\$94

PILATES & FLEXIBILITY

	RESIDENT	NON-RESIDENT
	\$20 --	\$30 --
	\$2 PER CLASS	\$3 PER CLASS

ADULT EXERCISE (CLEVELAND HILL)	RESIDENT	NON - RESIDENT
FULL YEAR (2X A WEEK)	\$100	\$110
WALK IN - \$3 PER DAY		

SWIMMING - SUMMER-FALL-WINTER

	RESIDENT		NON-RESIDENT	
YOUTH	\$39	(\$39)	\$49	(\$49)
SECOND CHILD	\$36	(\$36)	\$46	(\$46)
PARENT/INFANT	\$29	(\$29)	\$39	(\$39)
SECOND CHILD	\$26	(\$26)	\$36	(\$36)
PRE-SCHOOL	\$29	(\$29)	\$39	(\$39)
SECOND CHILD	\$26	(\$26)	\$36	(\$36)
WATER AEROBICS	\$39	(\$39)	\$49	(\$49)
ADULT	\$39	(\$39)	\$49	(\$49)
GUARD START	\$39	(\$39)	\$49	(\$49)
WATER SLIDE	\$ 1	(\$1)	\$ 1	(\$1)
DAILY USER FEE (Maryvale/Dingens)	\$ 7	(\$7)	\$ 7	(\$7)
DAILY USER FEE (Town Pool)	\$ 7	(\$7)	\$ 7	(\$7)
EVENING SWIM LESSONS	\$39	(\$39)	\$49	(\$49)
FALL 2014/ WINTER 2015				
YOUTH	\$39	(\$39)	\$49	(\$49)
SECOND CHILD	\$36	(\$36)	\$46	(\$46)
YOUTH SWIM LESSONS - 5 WEEKS				
	\$24		\$30	
SECOND CHILD	\$22		\$28	
LIFEGUARD TRAINING	\$137	(\$137)	\$177	(\$177)

Pool utilization for instructional groups will be charged \$30 per hour for 10 or less patrons. Five dollars more will be charged for every person above 10 in number. Rental availability subject to approval by the Pool Director.

INSTRUCTIONAL TENNIS

SUMMER	RESIDENT		NON-RESIDENT	
YOUTH	\$36	(\$35)	\$46	(\$45)
SECOND CHILD	\$31	(\$30)	\$41	(\$40)

WEE THREE-TWICE THE FUN 2014-15

RUNS - 2ND WEEK OF SEPT TILL END OF MAY BEFORE MEMORIAL DAY				
FALL/ WINTER/SPRING	RESIDENT		NON-RESIDENT	
PER CHILD	\$455	(\$455)	\$495	(\$495)
SECOND CHILD	\$405	(\$425)	\$445	(\$465)

MOM & ME FOR 2's and 3's

FALL/ WINTER	RESIDENT		NON-RESIDENT	
PER CHILD	\$36	(\$73)	\$41	(\$83)
SECOND CHILD	\$31	(\$68)	\$36	(\$78)

ART CAMP

RESIDENT	NON-RESIDENT
\$82 (\$82)	\$92 (\$92)

CHEER CAMP

RESIDENT	NON-RESIDENT
\$62 (\$62)	\$67 (\$67)

PUBLIC SKATE

FALL/WINTER GENERAL ADMISSION	\$5 (\$5)	
	W/ RESIDENT DISCOUNT CARD	
CHILDREN 3 AND UNDER	FREE	(FREE)
CHILDREN 4 TO 15	\$3	(\$3)
ADULTS 16 AND UP	\$4	(\$4)
BIRTHDAY PARTIES	\$8.00 PER PERSON	(\$8.00)
SCHOOL TIME SKATES	\$4.00 PER PERSON	(\$4)
SENIOR CITIZENS	\$2	(\$2)

LEARN TO SKATE (PER INDIVIDUAL)

	RESIDENT	NON-RESIDENT
FALL	\$50 (\$55)	\$70 (\$75)
WINTER/SPRING	\$40 (\$50)	\$60 (\$70)

ICE HOCKEY

FALL/ WINTER	RESIDENT				NON-RESIDENT	
	HOUSE	TRAVEL		HOUSE	TRAVEL	
NOVICE	\$500 (\$450)	N/A		\$700(\$650)	N/A	
MITE	\$500 (\$450)	N/A		\$700(\$650)	N/A	
SQUIRT	\$600 (\$550)	\$750 (\$700)		\$800(\$750)	\$950(\$900)	
PEE WEE	\$650 (\$600)	\$800 (\$750)		\$850(\$800)	\$1,000 (\$950)	
BANTAM	\$700 (\$650)	\$850 (\$800)		\$900(\$850)	\$1050 (\$1000)	
MIDGET	\$800 (\$750)	\$600 (\$545)		\$1000(\$950)	\$750 (\$700)	

- \$100 DISCOUNT FOR BALANCE(S) PAID IN FULL BY OCTOBER 15, 2015
- ALL COACHES WILL RECEIVE A \$150.00 REDUCTION FOR ONE CHILD
- SECOND CHILD ENROLLED FROM A FAMILY \$40.00 REDUCTION
- THIRD CHILD ENROLLED FROM A FAMILY \$90.00 REDUCTION
- FOURTH CHILD ENROLLED FROM A FAMILY \$150.00
- THERE WILL BE A \$100.00 LATE FEE FOR ANYONE NOT PAID IN FULL BY NOVEMBER 30TH OF EACH SEASON
- A \$200 NON-REFUNDABLE DEPOSIT IS REQUIRED TO REGISTER

ICE RENTALS

FALL/ WINTER PER HOUR	PRIME TIME	\$185 (\$185)	5:00pm-11:00pm M-F
			All day Sat and Sun and Holidays

NON-PRIME \$160 (\$160) 8:00am- 5:00pm
M-F - Except holidays

SPORT COURT RENTALS

PER HOUR \$80 (\$75)
PER HOUR AND HALF \$100 (\$95)
PER 2 HOURS \$135 (\$130)

INLINE HOCKEY

SUMMER	RESIDENT	NON-RESIDENT
YOUTH PARTICIPANT	\$80 (\$80)	\$110 (\$110)
NOVICE	\$25 (\$25)	\$35 (\$35)
ADULT TEAM \$885	(\$885)	\$945 (\$945)
JUNIOR A	\$30 (\$30)	\$60 (\$60)
INLINE GOALIE	\$40 (\$40)	\$55 (\$55)

** ADULT INLINE TEAMS ARE RESPONSIBLE FOR PAYMENT OF REFEREES
PRIOR TO THE START OF EACH GAME** \$100 DISCOUNT IF PAID IN FULL BY THE
TEAMS 1ST GAME

**\$150 for Jerseys (Optional)

HIGH SCHOOL IN LINE	\$625 (\$625)	\$700 (\$700)
MIDGET 18U & 16U	\$625 (\$625)	\$700 (\$700)

STREET HOCKEY LEAGUE

RESIDENT	NON-RESIDENT
\$225 (\$225)	\$275 (\$275)

INCLUDES REFEREE 80% OF TEAM MUST BE RESIDENTS FOR RESIDENT RATE

STREET HOCKEY FESTIVAL

RESIDENT	NON-RESIDENT
\$120 (\$110)	\$145 (\$135)

YOUTH SOCCER

SUMMER CHILD	RESIDENT	NON-RESIDENT
	\$58 (\$61)	\$74 (\$77)

ADULT INDOOR SOCCER 2015

ADULT, JUNIORS, MIDGET	\$560 (\$560)	\$625 (\$625)
------------------------	---------------	---------------

***\$50 DISCOUNT FOR TEAMS NOT IN NEED OF JERSEYS
(ADULT, JUNIORS AND MIDGET TEAMS PAY THE REFEREE FEES PRIOR TO THE
START OF THE GAME)

*\$100 DISCOUNT IF PAID IN FULL BY THE TEAMS 1ST GAME**

ALL STAR-ALL SPORTS	\$75 (\$75)	\$85 (\$85)
----------------------------	-------------	-------------

START SMART SOCCER	\$48 (\$48)	\$63 (\$63)
START SMART BASEBALL	\$60 (\$60)	\$70 (\$70)
START SMART BASKETBALL	\$60 (\$60)	\$70 (\$70)

YOUTH BASKETBALL

FALL/ WINTER PER PARTICIPANT	RESIDENT	NON-RESIDENT
	\$50 (\$50)	\$60 (\$60)

ADULT BASKETBALL

PER TEAM \$150 (\$150)

**TEAMS ARE RESPONSIBLE FOR PAYING REFEREE FEES EACH WEEK

YOUTH BOWLING LEAGUE (WITH INSTRUCTION)

RESIDENT	NON-RESIDENT
\$108	\$108

VOLLEYBALL (teams pay referee fees each week)

INDOOR FALL/ WINTER SESSIONS I & II (Monday, Thursday & Friday)

\$250 (\$250) per team

SUMMER

OUTDOOR LEAGUE \$150 per team

**TEAMS ARE RESPONSIBLE FOR PAYING REFEREE FEES EACH WEEK

DIAMOND PERMITS

SUMMER (per 2 hour time block)	RESIDENT	NON-RESIDENT
NO LIGHTS	\$60 (\$60)	\$80 (\$80)
LIGHTS	\$90 (\$90)	\$105 (\$105)

13 WEEK SERIES

NO LIGHTS	\$475 (\$475)	\$700 (\$700)
LIGHTS	\$775 (\$775)	\$950 (\$950)

Additional games added to 13-week series are charged at the regular 2-hour block rate

SOCCER / FOOTBALL FIELD RENTAL

	RESIDENT	NON-RESIDENT
PER TWO HOUR TIME BLOCK	\$70 (\$70)	\$85 (\$85)

VOLLEYBALL COURT RENTAL

	RESIDENT	NON-RESIDENT
1 COURT PER TWO HOUR BLOCK	\$50 (\$50)	\$70 (\$70)

PICNIC PAKS

\$20 (\$20) REFUNDABLE DEPOSIT \$20 (\$20) RENTAL FEE

TENNIS COURT RENTAL

1 HOUR BLOCK	RESIDENT	NON-RESIDENT
	\$15 (\$15)	\$30 (\$30)

ADULT SOFTBALL LEAGUES

SUMMER	LEAGUE RESIDENT	LEAGUE NON-RESIDENT
CO-ED	\$360 (\$360)	\$440 (\$440)
WOMEN'S	\$360 (\$360)	\$440 (\$440)
MEN'S	\$360 (\$360)	\$440 (\$440)
MEN'S OVER 40	\$360 (\$360)	\$440 (\$410)
WOODEN BAT LEAGUE	\$300 (\$300)	\$300 (\$300)
FALL - ALL LEAGUES - RESIDENT- \$190 (\$190)		\$190 (\$190)

**ALL TEAMS ARE RESPONSIBLE FOR PAYING THE UMPIRE FEES EACH WEEK

**THE \$25 ASA FEE WILL BE INCLUDED WITH THE REGISTRATION FEE

**ALL RESIDENT TEAMS MUST SUPPLY ID'S FOR EVERY PLAYER

KICKBALL LEAGUES

SUMMER	LEAGUE RESIDENT	LEAGUE NON-RESIDENT
(CO-ED TUES/THURS)	\$250 (\$250)	\$250 (\$250)
CHEEKTOWAGA FILM ACADEMY	RESIDENTS	NON-RESIDENTS
MON-WED-FRI CLASS	\$75 (\$75)	\$85 (\$85)
DIAMOND HAWK YOUTH GOLF	RESIDENTS	NON-RESIDENTS
TUESDAYS	\$90 (\$90)	\$100 (\$100)

CULTURAL CENTER (BAND SHELL) LOCATED IN TOWN PARK

THE RENTAL FEE IS FOR FOUR HOURS ANY TIME PRIOR TO OR AFTER THE SPECIFIED RENTAL TIME THE RENTER IS RESPONSIBLE FOR THE COSTS OF KEEPING STAFF ON.

RESIDENTS

\$400 for a four hour period Additional hours before or after the specified rental time will be billed at \$125 per hour.

NON-RESIDENTS

\$800 for a four hour period Additional hours before or after the specified rental time will be billed at \$195 per hour.

RESULT:	ADOPTED [UNANIMOUS]
MOVER:	Angela M. Wozniak, Councilmember
SECONDER:	James P. Rogowski, Councilmember
AYES:	Holtz, Rogowski, Kaminski, Wozniak, Benczkowski, Meyers



12. RESOLUTION 2014-622

Authorize Auction of Surplus Vehicles and Equipment

Sponsored By: Councilmember Kaminski, Supervisor Holtz

WHEREAS, the Town wishes to dispose of surplus vehicles and equipment no longer functional or needed for Town use; and

WHEREAS, sale of surplus property by the Town is authorized by Section 64 of the Town Law of the State of New York; and

WHEREAS, Auctions International, Inc. will sell such surplus vehicles and equipment at an online auction; NOW THEREFORE, BE IT

RESOLVED, that the Town hereby retains Auctions International, Inc., 11167 Big Tree Road (20A), East Aurora, New York, 14052, to conduct a sale of the surplus Town vehicles and equipment identified on the attached list entitled "Auction Fall 2014" at an online auction to be held on its website; and BE IT FURTHER

RESOLVED, that the Supervisor of the Town of Cheektowaga be and hereby is authorized to execute an agreement with Auctions International, Inc., subject to approval by the Town Attorney, and any and all documents that may be required to effectuate the sale and/or transfer of said surplus vehicles and equipment.

Attachments:

2014 Chktg. Auction - List of Surplus Vehicles (PDF)

RESULT:	ADOPTED [UNANIMOUS]
MOVER:	Gerald Kaminski, Councilmember
SECONDER:	Mary Holtz, Supervisor
AYES:	Holtz, Rogowski, Kaminski, Wozniak, Benczkowski, Meyers



13. RESOLUTION 2014-623

Hiring/Termination of Part-Time/Seasonal Employees

Sponsored By: Councilmember Kaminski, Supervisor Holtz

BE IT RESOLVED, that the following individual be and hereby is hired as a **SEASONAL EMPLOYEE**, not to exceed five (5) months in a calendar year, in the department listed and in compliance with Civil Service Laws and Regulations as well as the provisions of the Town's collective bargaining agreement between the Town of Cheektowaga and the Town of Cheektowaga Employees Association:

FACILITIES DEPARTMENT (Buildings and Grounds Division) Laborer \$9.00/hour effective 11/10/14

Andrew J. Ping, Sloan, New York

BE IT RESOLVED, that the following seasonal and/or part-time employees be and hereby are terminated as listed:

SANITATION DEPARTMENT

Jeffrey T. Lewis effective 10/1/14

RECORDS MANANGEMENT

Joseph A. Christiano effective 6/1/13

Carol Brunner effective 10/25/14

POLICE DEPARTMENT

Kristen M. Swiatek effective 11/4/14

BE IT RESOLVED, that the following employee's status be amended as follows:

OFFICE OF THE TOWN ASSESSOR Clerk from Part-Time to Seasonal \$9.00/hour effective 10/7/14

Alexandra M. Wachowski, Cheektowaga, New York

Motion by Councilmember Rogowski; Seconded by Councilmember Kaminski to waive the reading of names for this resolution. Motion Carried.

RESULT:	ADOPTED [UNANIMOUS]
MOVER:	Gerald Kaminski, Councilmember
SECONDER:	Mary Holtz, Supervisor
AYES:	Holtz, Rogowski, Kaminski, Wozniak, Benczkowski, Meyers



14. RESOLUTION 2014-624

Appointment of Maintenance Worker (Labor/Temporary)/Facilities Department (Buildings and Grounds Division) Mark P. Mez

Sponsored By: Councilmember Kaminski, Supervisor Holtz

WHEREAS, a temporary Maintenance Worker position exists in the Facilities Department (Buildings and Grounds Division); AND

WHEREAS, notice of such vacancy has been posted in accordance with the provisions of the Town's collective bargaining agreement with the Town of Cheektowaga Employees Association; AND

WHEREAS, no bargaining unit member bid on the vacancy; AND

WHEREAS, Mark P. Mez of Cheektowaga, New York, currently employed as a temporary Park Maintenance Worker I in the Facilities Department, applied for said vacancy and meets the qualifications for appointment; NOW, THEREFORE, BE IT

RESOLVED, that Mark P. Mez of Cheektowaga, New York be and hereby is appointed to the temporary position of Maintenance Worker in the Facilities Department (Buildings and Grounds Division) in accordance with the terms and conditions of the Town's collective bargaining agreement with the Town of Cheektowaga Employees Association effective November 5, 2014.

RESULT:	ADOPTED [UNANIMOUS]
MOVER:	Gerald Kaminski, Councilmember
SECONDER:	Mary Holtz, Supervisor
AYES:	Holtz, Rogowski, Kaminski, Wozniak, Benczkowski, Meyers



15. RESOLUTION 2014-625

Appointment of Sewer Maintenance Worker (Non-Competitive/Permanent) Saturnino J. Arvelo, Jr.

Sponsored By: Councilmember Kaminski, Supervisor Holtz

WHEREAS, a vacancy exists in the title of Sewer Maintenance Worker in the Sewer Maintenance Department; AND

WHEREAS, the posting of said vacancy has been waived by the Town of Cheektowaga Employees Association; AND

WHEREAS, Saturnino J. Arvelo, Jr., currently employed as a temporary Sewer Maintenance Worker in the Sewer Maintenance Department, meets the qualifications for permanent appointment; NOW, THEREFORE, BE IT

RESOLVED, that Saturnino J. Arvelo, Jr., of Depew, New York, be and hereby is appointed to the position of Sewer Maintenance Worker in the Sewer Maintenance Department in accordance with the terms and conditions of the Town's collective bargaining agreement with the Town of Cheektowaga Employees Association effective October 25, 2014.

RESULT:	ADOPTED [UNANIMOUS]
MOVER:	Gerald Kaminski, Councilmember
SECONDER:	Mary Holtz, Supervisor
AYES:	Holtz, Rogowski, Kaminski, Wozniak, Benczkowski, Meyers



16. RESOLUTION 2014-626

Appointment of Assessment Clerk (Provisional)/Office of the Town Assessor/Robin M. Anderson

Sponsored By: Councilmember Benczkowski, Councilmember Kaminski

WHEREAS, a vacancy exists in the position of Assessment Clerk in the Office of the Town Assessor; AND

WHEREAS, notice of said vacancy has been posted in accordance with the provisions of the Town's collective bargaining agreement with the Town of Cheektowaga Employees Association; AND

WHEREAS, no bids were received that met the minimum qualifications; AND

WHEREAS, no civil service list for said title currently exists; AND

WHEREAS, Robin M. Anderson applied for said vacancy and meets the qualifications for appointment; NOW, THEREFORE, BE IT

RESOLVED, that Robin M. Anderson of Depew, New York be and hereby is appointed to the provisional title of Assessment Clerk in accordance with the terms and conditions of the Town's collective bargaining agreement with the Town of Cheektowaga Employees Association, effective December 3, 2014.

RESULT:	ADOPTED [UNANIMOUS]
MOVER:	Diane Benczkowski, Councilmember
SECONDER:	Gerald Kaminski, Councilmember
AYES:	Holtz, Rogowski, Kaminski, Wozniak, Benczkowski, Meyers



17. RESOLUTION 2014-627

Appointment of Director of the Department of Information Technology and Records Management

Sponsored By: Supervisor Holtz, Councilmember Benczkowski

WHEREAS, the Town Supervisor has been overseeing the operations of the Information Technology Department and has recommended to the Town Board that it is in the best interest of the Town to have a Department Head oversee the operations and employees of the Information Technology Department; AND

WHEREAS, Lisa-Marie Bolognese has served as the Municipal Records Manager for the Town since 2002, has worked closely with the Information Technology staff and has proven herself to be fully capable of directing the activities of the Information Technology employees; AND

WHEREAS, the work performed in the areas of Records management and Information technology has become more closely aligned; NOW, THEREFORE, BE IT

RESOLVED, that the employees and operations in the Records Center and the employees and operations in Information Technology are now combined into one Department known as the Department of Information Technology & Records Management; NOW, THEREFORE, BE IT FURTHER

RESOLVED, that effective immediately Lisa-Marie Bolognese is appointed to the position of Director of the Department of Information Technology and Records Management at an annual salary of \$85,500, and BE IT FURTHER

RESOLVED, that the title of Director of the Department of Information Technology and Records Management shall be covered under the Personnel Policy for Exempt Employees who are Department Heads and is not part of any Bargaining Unit in the Town of Cheektowaga.

RESULT:	ADOPTED [UNANIMOUS]
MOVER:	Mary Holtz, Supervisor
SECONDER:	Diane Benczkowski, Councilmember
AYES:	Holtz, Rogowski, Kaminski, Wozniak, Benczkowski, Meyers



18. RESOLUTION 2014-628

Travel Authorization Police Department/Police Officers John Jones, Scott Leising, Justine Blackchief, and Thomas LaBelle

Sponsored By: Councilmember Benczkowski, Councilmember Kaminski

WHEREAS, an interview and interrogation training is being held December 3 through December 5, 2014 at Niagara University; AND

WHEREAS, Police Officers John Jones, Scott Leising, Justin Blackchief and Thomas LaBelle have been recommended to attend said training; AND

WHEREAS, Police Chief David Zack has submitted a request for travel authorization along with the proper paperwork in a timely manner; AND

WHEREAS, the total cost to the Town shall not exceed \$918; AND

WHEREAS, these expenses have been budgeted by the Department; NOW, THEREFORE, BE IT

RESOLVED, that Police Officers John Jones, Scott Leising, Justin Blackchief and Thomas LaBelle be and hereby are authorized to attend an Interview and Interrogation training being held December 3 through December 5, 2014 at Niagara University.

RESULT:	ADOPTED [UNANIMOUS]
MOVER:	Diane Benczkowski, Councilmember
SECONDER:	Gerald Kaminski, Councilmember
AYES:	Holtz, Rogowski, Kaminski, Wozniak, Benczkowski, Meyers

V. Suspension of Rules

Motion by Councilmember Rogowski; Seconded by Councilmember Meyers to waive the rules to include the following one (1) resolution: 2014-629. Motion Carried.
--



1. RESOLUTION 2014-629

Authorize Supervisor to Execute Agreement with Erie County for Senior Nutrition Program

Sponsored By: Supervisor Holtz, Councilmember Kaminski

WHEREAS, the Town of Cheektowaga operates nutrition programs for the elderly at the following facilities in the Town of Cheektowaga:

Infant of Prague Parish, 921 Cleveland Drive
 Cayuga Village Apartments Community Center, 100 Hutchens Drive
 Maryvale East Management Corp., 100 Moorman Drive
 Violet Senior Apartments, 11 Haley Lane
 Southwind Landing Senior Apartments, 5074 Transit Road
 Cheektowaga Senior Center, 3349 Broadway

and,

WHEREAS, agreements between the Town of Cheektowaga and the owners of the above facilities have been drafted relative to the continuation of the operation of said nutrition programs for the year 2015, and

WHEREAS, the County of Erie provides financing for such nutrition programs; and an agreement between the Town of Cheektowaga and the County of Erie has been drafted relative to the operation of such nutrition programs for the year 2015, NOW, THEREFORE, BE IT

RESOLVED, that the Supervisor be and hereby is authorized and directed to execute the above referenced agreements on behalf of the Town.

RESULT:	ADOPTED [UNANIMOUS]
MOVER:	Mary Holtz, Supervisor
SECONDER:	Gerald Kaminski, Councilmember
AYES:	Holtz, Rogowski, Kaminski, Wozniak, Benczkowski, Meyers

VI. Communications

A. Departmental Communications

1. Building Permit List - October 2014
2. Town of Cheektowaga Adopted Budget for 2015 - dated 11/3/2014

VII. Comments

A. Supervisor's Comments

B. Councilmember's Comments

C. Public Comments

VIII. Adjournment

Motion by Supervisor Holtz; Seconded by Councilmember Rogowski to adjourn the meeting at 7:25 PM

Alice Magierski, Town Clerk

617.20
Appendix B
Short Environmental Assessment Form

Instructions for Completing

Part 1 - Project Information. The applicant or project sponsor is responsible for the completion of Part 1. Responses become part of the application for approval or funding, are subject to public review, and may be subject to further verification. Complete Part 1 based on information currently available. If additional research or investigation would be needed to fully respond to any item, please answer as thoroughly as possible based on current information.

Complete all items in Part 1. You may also provide any additional information which you believe will be needed by or useful to the lead agency; attach additional pages as necessary to supplement any item.

Part 1 - Project and Sponsor Information				
Name of Action or Project: Express Mart #352				
Project Location (describe, and attach a location map): 2700 Union Road Cheektowaga, NY 14227, Town of Cheektowaga, County of Erie				
Brief Description of Proposed Action: Demolition of an existing (1) story 2,880sf express mart convenience store to construct a new (1) story 5,256 sf express mart convenience store with donut shop drive-thru and a detached (1) story 720sf single bay car wash. The existing canopy and pumps are to remain. The proposed redevelopment of the site also involves the milling and topping of the entire area of existing pavement for a smooth surface with proper drainage. The site has been designed based upon the zoning requirements for an MS use; we are applying for re-zoning from CM to MS from CM. The site revisions are set forth on the site plan submitted with this application.				
Name of Applicant or Sponsor: Carmina Wood Morris DPC		Telephone: 716-842-3165 ext 117 E-Mail: wferrie@cwm-ae.com		
Address: 487 Main Street Suite 600				
City/PO: Buffalo	State: NY	Zip Code: 14203		
1. Does the proposed action only involve the legislative adoption of a plan, local law, ordinance, administrative rule, or regulation? If Yes, attach a narrative description of the intent of the proposed action and the environmental resources that may be affected in the municipality and proceed to Part 2. If no, continue to question 2.			NO <input type="checkbox"/>	YES <input type="checkbox"/>
2. Does the proposed action require a permit, approval or funding from any other governmental Agency? If Yes, list agency(s) name and permit or approval: NYS DOT, NYS DEC - SPEDES, ECDPW, & ECDEP			NO <input type="checkbox"/>	YES <input checked="" type="checkbox"/>
3.a. Total acreage of the site of the proposed action?		1.45 acres		
b. Total acreage to be physically disturbed?		1.45 acres		
c. Total acreage (project site and any contiguous properties) owned or controlled by the applicant or project sponsor?		1.45 acres		
4. Check all land uses that occur on, adjoining and near the proposed action. <input type="checkbox"/> Urban <input type="checkbox"/> Rural (non-agriculture) <input type="checkbox"/> Industrial <input checked="" type="checkbox"/> Commercial <input type="checkbox"/> Residential (suburban) <input type="checkbox"/> Forest <input type="checkbox"/> Agriculture <input type="checkbox"/> Aquatic <input type="checkbox"/> Other (specify): _____ <input type="checkbox"/> Parkland				

5. Is the proposed action, a. A permitted use under the zoning regulations?	NO	YES	N/A
	<input type="checkbox"/>	<input checked="" type="checkbox"/>	<input type="checkbox"/>
b. Consistent with the adopted comprehensive plan?	NO	YES	N/A
	<input type="checkbox"/>	<input checked="" type="checkbox"/>	<input type="checkbox"/>
6. Is the proposed action consistent with the predominant character of the existing built or natural landscape?	NO	YES	
	<input type="checkbox"/>	<input checked="" type="checkbox"/>	
7. Is the site of the proposed action located in, or does it adjoin, a state listed Critical Environmental Area? If Yes, identify: _____	NO	YES	
	<input checked="" type="checkbox"/>	<input type="checkbox"/>	
8. a. Will the proposed action result in a substantial increase in traffic above present levels?	NO	YES	
	<input checked="" type="checkbox"/>	<input type="checkbox"/>	
b. Are public transportation service(s) available at or near the site of the proposed action?	NO	YES	
	<input type="checkbox"/>	<input checked="" type="checkbox"/>	
c. Are any pedestrian accommodations or bicycle routes available on or near site of the proposed action?	NO	YES	
	<input type="checkbox"/>	<input checked="" type="checkbox"/>	
9. Does the proposed action meet or exceed the state energy code requirements? If the proposed action will exceed requirements, describe design features and technologies: _____	NO	YES	
	<input type="checkbox"/>	<input checked="" type="checkbox"/>	
10. Will the proposed action connect to an existing public/private water supply? If No, describe method for providing potable water: _____	NO	YES	
	<input type="checkbox"/>	<input checked="" type="checkbox"/>	
11. Will the proposed action connect to existing wastewater utilities? If No, describe method for providing wastewater treatment: _____	NO	YES	
	<input type="checkbox"/>	<input checked="" type="checkbox"/>	
12. a. Does the site contain a structure that is listed on either the State or National Register of Historic Places?	NO	YES	
	<input checked="" type="checkbox"/>	<input type="checkbox"/>	
b. Is the proposed action located in an archeological sensitive area?	NO	YES	
	<input checked="" type="checkbox"/>	<input type="checkbox"/>	
13. a. Does any portion of the site of the proposed action, or lands adjoining the proposed action, contain wetlands or other waterbodies regulated by a federal, state or local agency?	NO	YES	
	<input checked="" type="checkbox"/>	<input type="checkbox"/>	
b. Would the proposed action physically alter, or encroach into, any existing wetland or waterbody? If Yes, identify the wetland or waterbody and extent of alterations in square feet or acres: _____	NO	YES	
	<input checked="" type="checkbox"/>	<input type="checkbox"/>	
14. Identify the typical habitat types that occur on, or are likely to be found on the project site. Check all that apply: <input type="checkbox"/> Shoreline <input type="checkbox"/> Forest <input type="checkbox"/> Agricultural/grasslands <input type="checkbox"/> Early mid-successional <input type="checkbox"/> Wetland <input checked="" type="checkbox"/> Urban <input checked="" type="checkbox"/> Suburban			
15. Does the site of the proposed action contain any species of animal, or associated habitats, listed by the State or Federal government as threatened or endangered?	NO	YES	
	<input checked="" type="checkbox"/>	<input type="checkbox"/>	
16. Is the project site located in the 100 year flood plain?	NO	YES	
	<input checked="" type="checkbox"/>	<input type="checkbox"/>	
17. Will the proposed action create storm water discharge, either from point or non-point sources? If Yes, a. Will storm water discharges flow to adjacent properties? <input checked="" type="checkbox"/> NO <input type="checkbox"/> YES	NO	YES	
	<input type="checkbox"/>	<input checked="" type="checkbox"/>	
b. Will storm water discharges be directed to established conveyance systems (runoff and storm drains)? If Yes, briefly describe: Municipal Storm System within the R.O.W. _____	NO	YES	
	<input type="checkbox"/> NO <input checked="" type="checkbox"/> YES		

Attachment: EAF 2700 Union Road (RES-2014-616 : Negative SEQR Declaration -2700 Union Road)

RESET

18. Does the proposed action include construction or other activities that result in the impoundment of water or other liquids (e.g. retention pond, waste lagoon, dam)? If Yes, explain purpose and size: _____ _____	NO	YES
	<input checked="" type="checkbox"/>	<input type="checkbox"/>
19. Has the site of the proposed action or an adjoining property been the location of an active or closed solid waste management facility? If Yes, describe: _____ _____	NO	YES
	<input checked="" type="checkbox"/>	<input type="checkbox"/>
20. Has the site of the proposed action or an adjoining property been the subject of remediation (ongoing or completed) for hazardous waste? If Yes, describe: _____ _____	NO	YES
	<input checked="" type="checkbox"/>	<input type="checkbox"/>
I AFFIRM THAT THE INFORMATION PROVIDED ABOVE IS TRUE AND ACCURATE TO THE BEST OF MY KNOWLEDGE		
Applicant/sponsor name: <u>Carmina Wood Morris DPC (Wendy Ferrie RA)</u> Date: <u>07.25.2014</u>		
Signature: <u><i>Wendy Ferrie</i></u>		

Part 2 - Impact Assessment. The Lead Agency is responsible for the completion of Part 2. Answer all of the following questions in Part 2 using the information contained in Part 1 and other materials submitted by the project sponsor or otherwise available to the reviewer. When answering the questions the reviewer should be guided by the concept "Have my responses been reasonable considering the scale and context of the proposed action?"

	No, or small impact may occur	Moderate to large impact may occur
1. Will the proposed action create a material conflict with an adopted land use plan or zoning regulations?	<input checked="" type="checkbox"/>	<input type="checkbox"/>
2. Will the proposed action result in a change in the use or intensity of use of land?	<input checked="" type="checkbox"/>	<input type="checkbox"/>
3. Will the proposed action impair the character or quality of the existing community?	<input checked="" type="checkbox"/>	<input type="checkbox"/>
4. Will the proposed action have an impact on the environmental characteristics that caused the establishment of a Critical Environmental Area (CEA)? N/A	<input type="checkbox"/>	<input type="checkbox"/>
5. Will the proposed action result in an adverse change in the existing level of traffic or affect existing infrastructure for mass transit, biking or walkway?	<input checked="" type="checkbox"/>	<input type="checkbox"/>
6. Will the proposed action cause an increase in the use of energy and it fails to incorporate reasonably available energy conservation or renewable energy opportunities?	<input checked="" type="checkbox"/>	<input type="checkbox"/>
7. Will the proposed action impact existing:		
a. public / private water supplies?	<input checked="" type="checkbox"/>	<input type="checkbox"/>
b. public / private wastewater treatment utilities?	<input checked="" type="checkbox"/>	<input type="checkbox"/>
8. Will the proposed action impair the character or quality of important historic, archaeological, architectural or aesthetic resources?	<input checked="" type="checkbox"/>	<input type="checkbox"/>
9. Will the proposed action result in an adverse change to natural resources (e.g., wetlands, waterbodies, groundwater, air quality, flora and fauna)?	<input checked="" type="checkbox"/>	<input type="checkbox"/>

RESET

Attachment: EAF 2700 Union Road (RES-2014-616 : Negative SEQR Declaration -2700 Union Road)

	No, or small impact may occur	Moderate to large impact may occur
10. Will the proposed action result in an increase in the potential for erosion, flooding or drainage problems?	<input checked="" type="checkbox"/>	<input type="checkbox"/>
11. Will the proposed action create a hazard to environmental resources or human health?	<input checked="" type="checkbox"/>	<input type="checkbox"/>

Part 3 - Determination of significance. The Lead Agency is responsible for the completion of Part 3. For every question in Part 2 that was answered "moderate to large impact may occur", or if there is a need to explain why a particular element of the proposed action may or will not result in a significant adverse environmental impact, please complete Part 3. Part 3 should, in sufficient detail, identify the impact, including any measures or design elements that have been included by the project sponsor to avoid or reduce impacts. Part 3 should also explain how the lead agency determined that the impact may or will not be significant. Each potential impact should be assessed considering its setting, probability of occurring, duration, irreversibility, geographic scope and magnitude. Also consider the potential for short-term, long-term and cumulative impacts.

<input type="checkbox"/>	Check this box if you have determined, based on the information and analysis above, and any supporting documentation, that the proposed action may result in one or more potentially large or significant adverse impacts and an environmental impact statement is required.
<input checked="" type="checkbox"/>	Check this box if you have determined, based on the information and analysis above, and any supporting documentation, that the proposed action will not result in any significant adverse environmental impacts.
<u>TOWN OF CHEEKTOWAGA</u>	<u>NOVEMBER 17, 2014</u>
Name of Lead Agency	Date
<u>DANIEL J. ULATOWSKI, AICP</u>	<u>TOWN PLANNER</u>
Print or Type Name of Responsible Officer in Lead Agency	Title of Responsible Officer
<u>[Signature]</u>	
Signature of Responsible Officer in Lead Agency	Signature of Preparer (if different from Responsible Officer)

Attachment: EAF 2700 Union Road (RES-2014-616 : Negative SEQR Declaration -2700 Union Road)

PRINT

RESET

All rights reserved. Reuse of these documents without the expressed written permission of Carmina Wood Morris PC is prohibited. WARNING: It is violation of article 145 sections 7209N and 7301 of the New York State education law for any person, unless acting under the direction of a registered architect, licensed engineer or land surveyor to alter this drawing. If altered such R.A., P.E. or L.L.S. shall affix his or her seal, signature, the date, the notation "altered by" and a specific description of the alteration.

© Carmina Wood Morris PC

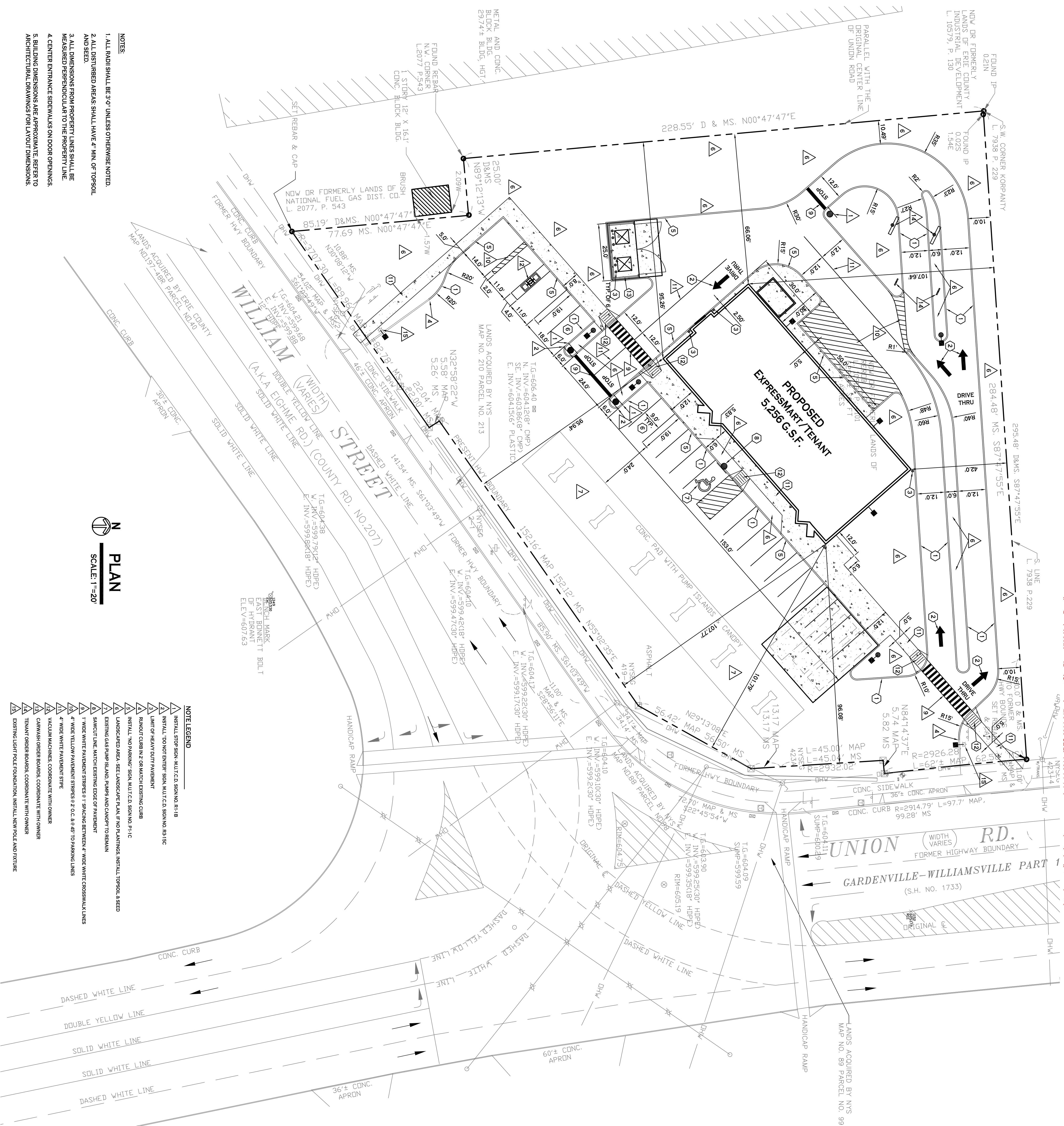

- NOTES:**
1. ALL ROAD SHALL BE 3'-0" UNLESS OTHERWISE NOTED.
 2. ALL DISTURBED AREAS SHALL HAVE 4" MIN. OF TOPSOIL AND SEED.
 3. ALL DIMENSIONS FROM PROPERTY LINES SHALL BE MEASURED PERPENDICULAR TO THE PROPERTY LINE.
 4. CENTER ENTRANCE SIDEWALKS ON DOOR OPENINGS.
 5. BUILDING DIMENSIONS ARE APPROXIMATE REFER TO ARCHITECTURAL DRAWINGS FOR LAYOUT DIMENSIONS.

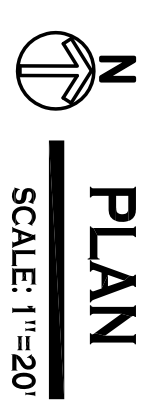

- NOTE LEGEND**
- ▲ INSTALL STOP SIGN, MULTICOLOR SIGN NO. R1-18
 - ▲ INSTALL "DO NOT ENTER" SIGN, MULTICOLOR SIGN NO. R3-15C
 - ▲ LIMIT OF HEAVY DUTY PAVEMENT
 - ▲ RADIUS CURB IN Z OR MATCH EXISTING CURB
 - ▲ INSTALL "NO PARKING" SIGN, MULTICOLOR SIGN NO. R1-1C
 - ▲ LANDSCAPE AREA - SEE LANDSCAPE PLAN, IF NO PLANTINGS, INSTALL TOPSOIL & SEED
 - ▲ EXISTING GAS PUMP ISLAND, RAMP AND CANOPY TO REMAIN
 - ▲ 4" WIDE WHITE PAVEMENT STRIPES @ 2' O.C. @ 8' & 9' TO PARKING LINES
 - ▲ 4" WIDE WHITE PAVEMENT STRIPES
 - ▲ VACUUM MACHINES, COORDINATE WITH OWNER
 - ▲ CARWASH ORDER BOARDS, COORDINATE WITH OWNER
 - ▲ TRUCK ORDER BOARDS, COORDINATE WITH OWNER
 - ▲ EXISTING LIGHT POLE FOUNDATION, INSTALL NEW POLE AND FIXTURE

- DETAIL LEGEND**
- 1. TIME 'N' CONCRETE CURB
 - 2. PAINTED TRAFFIC ARROWS
 - 3. PINE BOLLARD
 - 4. STANDBY DOT ASPHALT
 - 5. HEAVY DUTY ASPHALT
 - 6. EXTERIOR CONCRETE SLAB ON GRADE
 - 7. INTERIOR CONCRETE SLAB ON GRADE
 - 8. 90° PARKING STALL
 - 9. HANDICAPPED PARKING MARKINGS
 - 10. STOP BAR
 - 11. LIGHT POLE FOUNDATION
 - 12. CONCRETE SIDEWALK
 - 13. SIDEWALK CURB RAMP
 - 14. DIMENSION ENCLOSURE

- GENERAL NOTES:**
1. INSTALL ALL MATERIALS TO MANUFACTURER'S RECOMMENDATIONS AND BEST STANDARDS OF TRADE INVOLVED.
 2. SUBSTITUTIONS SHALL BE MADE ONLY WITH OWNER'S APPROVAL AND BE OF EQUIVALENT QUALITY TO WHAT IS SPECIFIED.
 3. WORK SHALL BE COMPLETED IN STRICT ACCORDANCE WITH ALL LOCAL CODES AND OSHA SAFETY RULES AND REGULATIONS.
 4. VERIFY ALL EXISTING CONDITIONS AND DIMENSIONS AT THE SITE. NOTIFY OWNER & ENGINEER WITH ANY DISCREPANCIES IN CONDITIONS SHOWN ON DRAWINGS PRIOR TO PROCEEDING.
 5. CONTRACTOR SHALL BE RESPONSIBLE FOR PROTECTION OF ANY EXISTING STRUCTURES TO REMAIN AND ANY FINISH MATERIAL INSTALLED WHILE WORKING ON OTHER COMPONENTS.
 6. CONTRACTOR SHALL KEEP JOB FREE OF DEBRIS AND MAKE FINAL CLEANUP TO SATISFACTION OF OWNER.
 7. CONTRACTOR SHALL ASCERTAIN THE LOCATION OF ALL UTILITIES PRIOR TO CONSTRUCTION SO THAT THIS WORK WILL NOT DISTURB EXISTING LINES AND/OR INSTALLATIONS. COORDINATE ALL WORK WITH THE APPLICABLE UTILITY COMPANIES.
 8. CONTRACTOR SHALL OBTAIN AND PAY FOR ALL REQUIRED PERMITS NECESSARY TO PERFORM THE WORK.

SITE DATA	
SITE AREA = 63,031 SQ. FT. (1.45 AC)	
ZONED: MS (MOTOR SERVICE DISTRICT)	
HOUSING 4,575 6.5 F. EXPRESS MART	
SETBACKS - NEW BUILDING	REQUIRED
FRONT YARD OPEN SPACE	50 FT
SIDE (ABUTTING NONRESIDENTIAL):	10 FT
REAR (ABUTTING NONRESIDENTIAL):	25 FT
SETBACKS - PARKING/LOADING/STACKING	
FRONT:	25 FT
SIDE (ABUTTING NONRESIDENTIAL):	10 FT
REAR (ABUTTING NONRESIDENTIAL):	10 FT
GREENSPACE	NO REQMT
INTERIOR OF PARKING AREA:	NO REQMT
OVERALL GREENSPACE	NO REQMT
% OF SITE DEVOTED TO GREEN SPACE	NO REQMT
PARKING	SEE CALCULATION BELOW
	18
	21

PARKING CALCULATION:
INDIVIDUAL RETAIL STORE (EXPRESS MART):
G.S.F. OF BUILDING = 5,256
REQ'D EXPRESS MART PARKING = 1 SPACE / 300 G.S.F. = 4,575 / 300 = 15 SPACES

DRAWING NO. C-100

Project no.: 14,048

Issued for Construction: 10.10.14
Municipality Submission: 11.14.14
Drawn by: JJP
Scale: 1/8"=1'-0"

DRAWING NAME:
Site Plan

PROJECT NAME:
New Construction
Express Mart #352
2700 Union Road
Corner of William & Union
Cheektowaga, NY

REVISIONS:

No.	Description	Date

Carmina Wood Morris
487 Main Street, Suite 600
Buffalo, New York 14203
F: 716.842.0283

AUCTION FALL 2014

VEHICLES

#	YEAR	MAKE	MODEL	VIN	MILEAGE	DEPT
1	2003	FORD	EXPEDITION	1FMFU16WX31LB66623	147,190	POLICE #81
2	2001	FORD	EXCURSION	1FMNU141L91EC46779	116,305	POLICE #80
3	2000	CHEVY	2500 PICK UP W/PLOW	1GCGK24R0YR196168	54,671	PARKS #122
4	1998	CHEVY	2500 PICK UP W/PLOW	1GCGK24R7WZ215814	73,430	PARKS #110
5	1997	DODGE	RAM WAGON VAN	2B5WB35Z8VK530552	24,761	YOUTH&REC #152
6	1999	FORD	WINDSTAR VAN	2FTZA544XXBB21125	40,157	POOL # 87
7	2003	FORD	TAURUS	1FAFP53243A162900	69,754	POLICE #88
8	2003	FORD	TAURUS	1FAFP52U33A109009	74,909	POLICE #61
9	2004	FORD	CROWN/VIC	2FAHP71W74X157614	103,872	POLICE #91
10	2009	FORD	CROWN/VIC	2FAHP71V19X138376	135,871	POLICE #43
11	2007	FORD	CROWN/VIC	2FAFP71W37X145500	133,636	POLICE #12
12	2010	FORD	CROWN/VIC	2FABP7BV7AX132963	157,552	POLICE #1
13	2007	FORD	CROWN/VIC	2FAHP71W57X145501	142,853	POOL #97
14	1993	FORD	35 C VAN	1FDKE30M2PHB51007	36,292	POLICE #36
15	1987	FORD	TRACTOR	C769594	1710 HRS	FACILITIES #128
16	UNK	MELROE	BOBCAT 742	5018-M-20317	2458 HRS	SANITATION
17	UNK	TRUCK	CAP	NONE		DOG WARDEN
18	UNK	TRUCK	TOOL BOX	NONE		PARKS
19	UNK	POWER	AMERICAN	PRESSURE WASHER	UNK	SANITATION
20	UNK	TRACTOR	WHEELS & TIRES	NONE	UNK	PARKS

21	1999	BEAR MOTOASPIRATORE	S/N SC99G68	UNK	FACILITIES
22	UNK	JACOBSEN 742222B Z-TURN	S/N 74222200277	999	FACILITIES
23	UNK	11 TOSIHIBA E STUDIO COPIERS	3500C	UNK	TOWN HALL
24	UNK	9 CROWN/VIC POLICE PARTITIONS	NONE	NONE	POLICE
25	UNK	5 EMERGENCY LIGHT BARS	NONE	UNK	POLICE
26	UNK	2 EXPLOSION PROOF MOTORS	NONE	UNK	SEWER
27	UNK	SUV CARGO COMMAND CENTER BOXES		UNK	POLICE
28	UNK	SUV CARGO COMMAND CENTER BOXES		UNK	POLICE

CHEEKTOWAGA SEWER MAINTENANCE DEPARTMENT

Auction Fall 2014 Page 3

AUCTION ITEMS

PUMP NO.	PUMP SIZE	ENGINE	MODEL NO.	SERIAL NO.	PUMP	MODEL NO.	SERIAL NO.
16	6"	FORD	172GF-6006-G	00120-G344	GORMON RUPP	16A2-D	631203
14	6"	FORD	172GF-6006-G	05929	GORMON RUPP	16A2-D	611198
13	4"	WISCONSIN	VH4D	4456896	GORMON RUPP	14AZ-VF4D	410751
7	4"	WISCONSIN	VH4D	5646138	GORMON RUPP	14AZ-VH4D	628992
1	4"	WISCONSIN	VH4D	3912306160424	GORMON RUPP	14AZ-VH4D	346023

1989 SRECO ROD MACHINE	MODEL NO. - RSR-375TR	SERIAL NO. - L-901768
------------------------	-----------------------	-----------------------



Town of Cheektowaga

Regular Meeting

~ Minutes ~

Cheektowaga, NY 14227

<http://www.town.cheektowaga.ny.us>

Alice Magierski
716-686-3400

Monday, December 1, 2014

6:45 PM

Council Chambers

I. Call to Order

6:45 PM Meeting called to order on December 1, 2014 at Council Chambers, 3301 Broadway St, Cheektowaga, NY.

Attendee Name	Organization	Title	Status	Arrived
Mary Holtz	Town of Cheektowaga	Supervisor	Present	
James P. Rogowski	Town of Cheektowaga	Councilmember	Present	
Gerald Kaminski	Town of Cheektowaga	Councilmember	Present	
Angela M. Wozniak	Town of Cheektowaga	Councilmember	Present	
Diane Benczkowski	Town of Cheektowaga	Councilmember	Present	
Timothy J. Meyers	Town of Cheektowaga	Councilmember	Present	

2. Additional Attendees

Patrick Bowen, Town Engineer
Brian Krause, Director of Finance and Administration
Karen Marchese, Coordinator of Employee Relations
Kevin Schenk, Town Attorney

II. Public Comment Period

III. Resolutions



1. RESOLUTION 2014-630

Warrant

Sponsored By: Supervisor Holtz, Councilmember Kaminski

BE IT RESOLVED, that the following Vouchers & Warrants submitted to the Town of Cheektowaga prior to December 1, 2014 are hereby approved and made part hereof;

GENERAL FUND	\$229,789.64
RISK RETENTION FUND	23,762.45
NYS HOME PROGRAM	0.00
DEBT	0.00
HUD HOUSING REHABILITATION FUND	0.00
SPECIAL DISTRICTS FUND	121,730.78
HIGHWAY FUND	18,556.03
CAPITAL FUND	212,376.53
TRUST & AGENCY FUND	3,449.00
HUD CDBG FUND	0.00
PART TOWN FUND	3,133.16
NYS AFFORDABLE HOUSING	0.00
	\$612,797.59

RESULT:	ADOPTED [UNANIMOUS]
MOVER:	Mary Holtz, Supervisor
SECONDER:	Gerald Kaminski, Councilmember
AYES:	Holtz, Rogowski, Kaminski, Wozniak, Benczkowski, Meyers



2. RESOLUTION 2014-631

Rescind Resolution 2014-619 - Notice of Hearing for Demolition of 169 Garland Avenue

Sponsored By: Councilmember Benczkowski, Councilmember Meyers

WHEREAS, on November 17, 2014, this Town Board adopted Resolution 2014-619 calling for a hearing for the demolition of structure(s) located at **169 Garland Avenue in the Town of Cheektowaga (S.B.L. No. 113.63-2-24)**; and

WHEREAS, as a result of the area snow storm and state of emergency declared in Town, it was not possible to timely notify all parties who may have an interest in and to said real property and said Notice of Hearing must be revised; NOW THEREFORE, BE IT

RESOLVED, that Resolution 2014-619, adopted November 17, 2014, be and hereby is rescinded in its entirety.

RESULT:	ADOPTED [UNANIMOUS]
MOVER:	Diane Benczkowski, Councilmember
SECONDER:	Timothy J. Meyers, Councilmember
AYES:	Holtz, Rogowski, Kaminski, Wozniak, Benczkowski, Meyers



3. RESOLUTION 2014-632

Rescind Resolution 2014-620 - Notice of Hearing for Demolition of 274 Cherokee Drive

Sponsored By: Councilmember Benczkowski, Councilmember Meyers

WHEREAS, on November 17, 2014, this Town Board adopted Resolution 2014-620 calling for a hearing for the demolition of structure(s) located at **274 Cherokee Drive in the Town of Cheektowaga (S.B.L. No. 91.19-7-19)**; and

WHEREAS, as a result of the area snow storm and state of emergency declared in Town, it was not possible to timely notify all parties who may have an interest in and to said real property and said Notice of Hearing must be revised; NOW THEREFORE, BE IT

RESOLVED, that Resolution 2014-620, adopted November 17, 2014, be and hereby is rescinded in its entirety.

RESULT:	ADOPTED [UNANIMOUS]
MOVER:	Diane Benczkowski, Councilmember
SECONDER:	Timothy J. Meyers, Councilmember
AYES:	Holtz, Rogowski, Kaminski, Wozniak, Benczkowski, Meyers



4. RESOLUTION 2014-633

Call for Public Hearing - 4646 Genesee Street Rezoning Request

Sponsored By: Councilmember Benczkowski, Councilmember Rogowski

WHEREAS, 4646 Genesee, LLC has made application and requested the rezoning of 4646 Genesee Street from CM- General Commercial to MS- Motor service for a proposed car rental facility , NOW, THEREFORE BE IT

RESOLVED, that a Public Hearing be held regarding said request under the provisions of the Zoning Law on the 15th of December, 2014 at 6:45 P.M., at the Cheektowaga Town Hall, 3301 Broadway at the corner of Union Road.



Notice of Public Hearing

NOTICE IS HEREBY GIVEN that a Public Hearing will be held by the Town Board of the Town of Cheektowaga, Erie County, New York at the Town Hall in the said Town of Cheektowaga, 3301 Broadway corner of Union Road on the 15th of December, 2014 at 6:45 o'clock P.M., of said day for the purpose of considering the application of:

4646 Genesee, LLC

For the rezoning of 4646 Genesee Street from CM- General Commercial to MS-Motor Service for a car rental facility.

All parties in interest and citizens will be given an opportunity to be heard in regard to such proposed application.

BY ORDER OF THE TOWN BOARD, Town of Cheektowaga, NY

Alice Magierski, TOWN CLERK



All that tract or parcel of land situate in Town of Cheektowaga, County of Erie, and State of New York; being part of Lot Number 77, Township 11, Range 7 of the Holland Land Company's Survey, and bounded and described as follows:

COMMENCING at a point in the center line of Genesee Street, 924.23 feet east of the west line of Lot No. 77; thence northeasterly and at an exterior angle of 97 ° 49' 5" a distance of 191.40 feet to an angle; thence northeasterly and at an interior angle of 175 ° 54' 25" a distance of 191.12 feet to the southwest line of the Lehigh Valley Railroad; thence southeasterly and along the south line of the Lehigh Valley Railroad to the center line of Genesee Street; thence southwesterly and along the center line of Genesee Street to the point or place of beginning.

EXCEPTING THEREFROM that part lying within the boundaries of Genesee Street;

ALSO EXCEPTING THEREFROM that part taken by the State of New York by Notice of Appropriation recorded in Liber 9501 of Deeds at page 244 and designated as Map No. 75 Parcel No. 76.

ALSO EXCEPTING THEREFROM, that part taken by the State of New York by Notice of Appropriation recorded in Liber 10387 of Deeds at page 200 and designated as Map No. 88 Parcel No. 90.

RESULT:	ADOPTED [UNANIMOUS]
MOVER:	Diane Benczkowski, Councilmember
SECONDER:	James P. Rogowski, Councilmember
AYES:	Holtz, Rogowski, Kaminski, Wozniak, Benczkowski, Meyers



5. RESOLUTION 2014-634

Notice of Hearing for Demolition of 169 Garland Avenue

Sponsored By: Supervisor Holtz, Councilmember Benczkowski

WHEREAS, the Supervising Code Enforcement Officer has received information that the structure(s) located at **169 Garland Avenue in the Town of Cheektowaga (S.B.L. No. 113.63-2-24)** has become dangerous and unsafe to the general public and unfit for the purposes for which it may lawfully be used; and

WHEREAS, said building has been inspected and a written report of the condition has been completed by Nussbaumer & Clarke, Inc., duly authorized agent of the Town of Cheektowaga, setting forth its findings and recommendations in regard to the repair or demolition and removal of the building, and said written report describes extensive deterioration and damage to the building and premises and recommends that the building be demolished and removed as soon as possible; and

WHEREAS, the Town Board has fully considered such written report and has determined that the building is dangerous and unsafe to the general public and unfit for the purposes for which it may lawfully be used; NOW THEREFORE BE IT

RESOLVED, that this Town Board accepts the findings and recommendations of Nussbaumer & Clarke, Inc., dated **August 18, 2014**; and BE IT FURTHER

RESOLVED, that a notice shall be served, pursuant to Section 75-7 of the Cheektowaga Town Code, upon the owner, executor, administrator, agent, lessee or any person having a vested or contingent interest in such unsafe building as shown by the records of the Receiver of Taxes or of the County Clerk, which notice shall have the contents prescribed by Section 75-6 of said Town Code, including, but not limited to a date, time and place for a hearing before the Town Board in relation to such dangerous and unsafe building, which hearing shall be scheduled not less than five business days from the date of service of the notice; and BE IT FURTHER

RESOLVED, that a hearing before this Board in relation to this dangerous and unsafe building shall be held on the **15th day of December, 2014 at 6:45 P.M.** at the Cheektowaga Town Hall, 3301 Broadway, Cheektowaga, New York, and BE IT FURTHER

RESOLVED, that the Code Enforcement Office and/or the Town Attorney's Office be and hereby are directed to serve notice of said hearing on all interested parties.

RESULT:	ADOPTED [UNANIMOUS]
MOVER:	Mary Holtz, Supervisor
SECONDER:	Diane Benczkowski, Councilmember
AYES:	Holtz, Rogowski, Kaminski, Wozniak, Benczkowski, Meyers



6. RESOLUTION 2014-635

Notice of Hearing for Demolition of 274 Cherokee Drive

Sponsored By: Supervisor Holtz, Councilmember Benczkowski

WHEREAS, the Supervising Code Enforcement Officer has received information that the structure(s) located at **274 Cherokee Drive in the Town of Cheektowaga (S.B.L. No. 91.19-7-19)** has become dangerous and unsafe to the general public and unfit for the purposes for which it may lawfully be used; and

WHEREAS, said building has been inspected and a written report of the condition has been completed by Nussbaumer & Clarke, Inc., duly authorized agent of the Town of Cheektowaga, setting forth its findings and recommendations in regard to the repair or demolition and removal of the building, and said written report describes extensive deterioration and damage to the building and premises and recommends that the building be demolished and removed as soon as possible; and

WHEREAS, the Town Board has fully considered such written report and has determined that the building is dangerous and unsafe to the general public and unfit for the purposes for which it may lawfully be used; NOW THEREFORE BE IT

RESOLVED, that this Town Board accepts the findings and recommendations of Nussbaumer & Clarke, Inc., dated **July 9, 2014**; and BE IT FURTHER

RESOLVED, that a notice shall be served, pursuant to Section 75-7 of the Cheektowaga Town Code, upon the owner, executor, administrator, agent, lessee or any person having a vested or contingent interest in such unsafe building as shown by the records of the Receiver of Taxes or of the County Clerk, which notice shall have the contents prescribed by Section 75-6 of said Town Code, including, but not limited to a date, time and place for a hearing before the Town Board in relation to such dangerous and unsafe building, which hearing shall be scheduled not less than five business days from the date of service of the notice; and BE IT FURTHER

RESOLVED, that a hearing before this Board in relation to this dangerous and unsafe building shall be held on the **15th day of December, 2014 at 6:45 P.M.** at the Cheektowaga Town Hall, 3301 Broadway, Cheektowaga, New York, and BE IT FURTHER

RESOLVED, that the Code Enforcement Office and/or the Town Attorney's Office be and hereby are directed to serve notice of said hearing on all interested parties.

RESULT:	ADOPTED [UNANIMOUS]
MOVER:	Mary Holtz, Supervisor
SECONDER:	Diane Benczkowski, Councilmember
AYES:	Holtz, Rogowski, Kaminski, Wozniak, Benczkowski, Meyers



7. RESOLUTION 2014-636

Authorize Supervisor to Execute Agreement with Erie County for Transportation Services for the Elderly

Sponsored By: Supervisor Holtz, Councilmember Kaminski

WHEREAS, the Town of Cheektowaga, in concert with the County of Erie, has been for years operating a transportation program for the elderly utilizing vans, and

WHEREAS, the County of Erie has prepared and submitted to the Town an agreement between the Town of Cheektowaga and the County of Erie relative to the operation of said transportation program for the Year 2015, and

WHEREAS, the Town of Cheektowaga wishes to continue to offer this service to our Town residents, NOW, THEREFORE, BE IT

RESOLVED, that the Supervisor be and hereby is authorized and directed to execute the above referenced agreement on behalf of the Town.

RESULT:	ADOPTED [UNANIMOUS]
MOVER:	Mary Holtz, Supervisor
SECONDER:	Gerald Kaminski, Councilmember
AYES:	Holtz, Rogowski, Kaminski, Wozniak, Benczkowski, Meyers



8. RESOLUTION 2014-637

Unsafe-Unsecured/16 A-D Glenwood Court

Sponsored By: Supervisor Holtz, Councilmember Benczkowski

WHEREAS, Town of Cheektowaga Law for the Administration and Enforcement of the Codes of New York State; and the Property Maintenance Code of New York State require that all vacant structures and premises shall be maintained in clean, safe, secure and sanitary conditions so as not to cause a blighting problem or adversely affect the public health or safety and all nuisances abated, AND

WHEREAS, the Town of Cheektowaga has received notification of an unsafe structure and premises located at 16 A-D Glenwood Court, Cheektowaga, New York SBL# 91.15-1-15 that is a danger to the safety of others, and records kept by the Assessors Office identify Louis Migliore, 1034 Amherst Street, Buffalo, New York 14216, as the owner AND

WHEREAS, an inspection of such premises was conducted at 16 A-D Glenwood Court, by the Housing and Neighborhood Preservation Office, AND

WHEREAS, such inspection found the premises to be deteriorated, vacant, a hazard, and a danger to the safety and well being of others, AND

WHEREAS, the Town of Cheektowaga Housing and Neighborhood Preservation Office properly notified the property owner in accordance with the Town of Cheektowaga Law for the Administration and Enforcement of the Codes of New York State, and the owner failed to take actions to safeguard the premises, AND

WHEREAS, these conditions require the Town of Cheektowaga Housing and Neighborhood Preservation Office to take immediate steps to safeguard the premises to protect the health and safety of others and abate all nuisances, NOW, THEREFORE BE IT

RESOLVED, that pursuant to Section 70-7A.(5) and Section 70-8 of the Town of Cheektowaga Law for the Administration and Enforcement of the Codes of New York State that the vacant structure premises be safeguarded and all nuisances abated; and all costs incurred be assessed against the property hereinbefore described.

RESULT:	ADOPTED [UNANIMOUS]
MOVER:	Mary Holtz, Supervisor
SECONDER:	Diane Benczkowski, Councilmember
AYES:	Holtz, Rogowski, Kaminski, Wozniak, Benczkowski, Meyers

IV. Suspension of Rules

Motion by Councilmember Rogowski; Seconded by Councilmember Meyers to Waive the Rules to Include the Following Resolution: 2014-638. Motion Carried.



1. RESOLUTION 2014-638

Travel Authorization Justice Court/Dennis Gorski

Sponsored By: Councilmember Kaminski, Supervisor Holtz

WHEREAS, the Taking the Bench Certification course is being held December 8 through December 13, 2014 in Castleton-on-Hudson, New York; AND

WHEREAS, Town Justice (Elect) Dennis Gorski by law must attend said course prior to swearing in to his elected position as Town Justice; AND

WHEREAS, the total cost to the Town shall not exceed \$2,500; AND

WHEREAS, these expenses have been budgeted by the Department; NOW,
THEREFORE, BE IT

RESOLVED, that Town Justice (Elect) Dennis Gorski be and hereby is authorized to attend the Taking the Bench Certification course being held December 8 through December 13, 2014 in Castleton-on-Hudson, New York.

RESULT:	ADOPTED [UNANIMOUS]
MOVER:	Gerald Kaminski, Councilmember
SECONDER:	Mary Holtz, Supervisor
AYES:	Holtz, Rogowski, Kaminski, Wozniak, Benczkowski, Meyers

V. Communications

A. Departmental Communications

B. General Communications

1. **Notice of Claim: Jill Benninger vs. Town of Cheektowaga**
2. **Notice of Claim: Connie Jendrasik vs. Town of Cheektowaga**
3. **Notice of Claim: Denise Matos vs. Town of Cheektowaga**
4. **Notice of Claim: Leonard Neureuther vs. Town of Cheektowaga**
5. **Notice of Claim: David Saskowski vs. Town of Cheektowaga**

- 6. Notice of Claim: Michael Storms vs. Town of Cheektowaga
- 7. Notice of Claim: Erin Whalen vs. Town of Cheektowaga

VI. Comments

A. Supervisor's Comments

B. Councilmember's Comments

C. Public Comments

VII. Adjournment

Motion by Supervisor Holtz; Seconded by Councilmember Meyers to adjourn the meeting at 7:56 PM

Alice Magierski, Town Clerk



Town of Cheektowaga

Work Session

~ Minutes ~

Cheektowaga, NY 14227

<http://www.town.cheektowaga.ny.us>

Alice Magierski
716-686-3400

Tuesday, December 9, 2014

6:00 PM

Council Office

I. Call to Order

6:00 PM Meeting called to order on December 9, 2014 at Council Office, Conference Room, Cheektowaga, NY.

Attendee Name	Organization	Title	Status	Arrived
Mary Holtz	Town of Cheektowaga	Supervisor	Present	
James P. Rogowski	Town of Cheektowaga	Councilmember	Present	
Gerald Kaminski	Town of Cheektowaga	Councilmember	Present	
Angela M. Wozniak	Town of Cheektowaga	Councilmember	Present	
Diane Benczkowski	Town of Cheektowaga	Councilmember	Present	
Timothy J. Meyers	Town of Cheektowaga	Councilmember	Present	

2. Additional Attendees

Patrick Bowen, Town Engineer

Brian Krause, Director of Finance and Administration

Karen Marchese, Coordinator of Employee Relations

II. Resolutions



1. RESOLUTION 2014-639

Authorize Supervisor to Execute Application for Response to Victim Grant

Sponsored By: Councilmember Benczkowski, Councilmember Kaminski

WHEREAS, funding is available for a "Response to Victim" grant under the International Association of Chiefs of Police (IACP), in partnership with the Office for Victims of Crimes, AND

WHEREAS, IACP would reimburse the Town of Cheektowaga for the offset of personnel and other operational costs related to providing a demonstration site to assess the needs of crime victims; assess and determine gaps in current efforts; develop a plan to enhance efforts and implement the ELERV Strategy; and execute the implementation plan in our community; AND

WHEREAS, the Town of Cheektowaga wishes to avail itself of said funding in an amount not to exceed \$100,000 per year over three years, to enhance responses to victims, NOW, THEREFORE, BE IT

RESOLVED, that the Town of Cheektowaga Police Department is authorized and directed to make application for the above referenced Response to Victim grant funding on behalf of the Town, and BE IT FURTHER

RESOLVED, that the Supervisor be and hereby is authorized and directed to execute any and all documents pertaining to the acquisition of the "Response to Victim" grant funding on behalf of the Town of Cheektowaga, including all contractual and reporting documents.

RESULT:	ADOPTED [UNANIMOUS]
MOVER:	Diane Benczkowski, Councilmember
SECONDER:	Gerald Kaminski, Councilmember
AYES:	Holtz, Rogowski, Kaminski, Wozniak, Benczkowski, Meyers



2. RESOLUTION 2014-640

Change Order No. 1 - Rehabilitation of the Rein Road Bridge

Sponsored By: Councilmember Meyers, Supervisor Holtz

WHEREAS, by resolution dated July 21, 2014 this Town Board awarded a contract for the Rehabilitation of the Rein Road Bridge spanning Ellicott Creek, PIN 5758.38, BIN 2212970 in the total amount of \$810,782.90 to Hunting Valley Construction, Inc., AND

WHEREAS, the contractor, Hunting Valley Construction, Inc. experienced delays due to the recent snow storm and subsequent flooding of Ellicott Creek and has requested a contract extension of time to complete the rehabilitation work. The requested extension moves the completion date to January 16, 2015, AND

WHEREAS, the Town, State of New York, and the United States of America will incur no additional costs as a result of the requested contract extension, AND

WHEREAS, no liquidated damages will be assessed to Hunting Valley Construction, Inc. for the period of time covering the requested extension, AND

WHEREAS, Greenman Pedersen, Inc., Project Engineer, and the Town Engineer have recommended approval of Change Order No. 1 for the aforesaid project which provides for the extension of the construction contract completion date to January 16, 2015, all of which is detailed in the Change Order No. 1 document dated November 26, 2014, NOW, THEREFORE, BE IT

RESOLVED, that Change Order No. 1 for the aforementioned project to the contract of Hunting Valley Construction, Inc., 825 Rein Road, Cheektowaga, New York 14225 be and hereby is approved, AND, BE IT FURTHER

RESOLVED, that the Supervisor is hereby authorized and directed to execute said Change Order No. 1 on behalf of this Town Board.

RESULT:	ADOPTED [UNANIMOUS]
MOVER:	Timothy J. Meyers, Councilmember
SECONDER:	Mary Holtz, Supervisor
AYES:	Holtz, Rogowski, Kaminski, Wozniak, Benczkowski, Meyers

III. Adjournment

Motion by Supervisor Holtz; Seconded by Councilmember Meyers to adjourn the work session at 7 PM.

Brian Wielinski, Deputy Town Clerk



Town of Cheektowaga

Regular Meeting

~ Minutes ~

Cheektowaga, NY 14227
<http://www.town.cheektowaga.ny.us>

Alice Magierski
716-686-3400

Monday, December 15, 2014

6:45 PM

Council Chambers

I. Call to Order

6:45 PM Meeting called to order on December 15, 2014 at Council Chambers, 3301 Broadway St, Cheektowaga, NY.

Attendee Name	Organization	Title	Status	Arrived
Mary Holtz	Town of Cheektowaga	Supervisor	Absent	
James P. Rogowski	Town of Cheektowaga	Councilmember	Present	
Gerald Kaminski	Town of Cheektowaga	Councilmember	Present	
Diane Benczkowski	Town of Cheektowaga	Councilmember	Present	
Timothy J. Meyers	Town of Cheektowaga	Councilmember	Present	

2. Additional Attendees

Patrick Bowen, Town Engineer
Brian Krause, Director of Finance and Administration
Karen Marchese, Coordinator of Employee Relations
Kevin Schenk, Town Attorney
Mark Wegner, Highway Superintendent

II. Public Comment Period

III. Public Hearings

1. Rezoning Request - 4646 Genesee Street from CM to MS

COMMENTS - Current Meeting:

This being the time and place advertised for a Public Hearing, the Supervisor directed the Town Clerk to present that such notice has been duly published and posted; upon the order of the Supervisor such proof was duly filed.

The Supervisor announced that the Town Board would hear all persons interested in the subject of the hearing. Comments were heard, after which the Supervisor declared the hearing closed, decision was reserved.

RESULT: CLOSED [UNANIMOUS]
MOVER: Diane Benczkowski, Councilmember
SECONDER: James P. Rogowski, Councilmember
AYES: James P. Rogowski, Gerald Kaminski, Diane Benczkowski, Timothy J. Meyers
ABSENT: Mary Holtz

2. Demolition of 169 Garland Avenue

COMMENTS - Current Meeting:

This being the time and place advertised for a Public Hearing, the Supervisor directed the Town Clerk to present that such notice has been duly published and posted; upon the order of the Supervisor such proof was duly filed.

The Supervisor announced that the Town Board would hear all persons interested in the subject of the hearing. Comments were heard, after which the Supervisor declared the hearing closed, decision was reserved.

RESULT: CLOSED [UNANIMOUS]
MOVER: Gerald Kaminski, Councilmember
SECONDER: Diane Benczkowski, Councilmember
AYES: James P. Rogowski, Gerald Kaminski, Diane Benczkowski, Timothy J. Meyers
ABSENT: Mary Holtz

3. Demolition of 274 Cherokee Drive

COMMENTS - Current Meeting:

This being the time and place advertised for a Public Hearing, the Supervisor directed the Town Clerk to present that such notice has been duly published and posted; upon the order of the Supervisor such proof was duly filed.

The Supervisor announced that the Town Board would hear all persons interested in the subject of the hearing. Comments were heard, after which the Supervisor declared the hearing closed, decision was reserved.

RESULT: CLOSED [UNANIMOUS]
MOVER: Gerald Kaminski, Councilmember
SECONDER: James P. Rogowski, Councilmember
AYES: James P. Rogowski, Gerald Kaminski, Diane Benczkowski, Timothy J. Meyers
ABSENT: Mary Holtz

IV. Resolutions



1. RESOLUTION 2014-641

Transfer of Funds

Sponsored By: Councilmember Kaminski, Councilmember Rogowski

BE IT RESOLVED, that the following transfer is hereby approved and made part hereof;

GENERAL

FROM:	100.1685.4051	Record Management	\$6,800.00
	100.1685.4051	Record Management	1,500.00
	100.1355.4575	2014 Contracted Appraisals	2,500.00
TO:	100.1685.2000	Equipment	\$6,800.00
	100.1685.2000	Equipment	1,500.00
	100.1355.2005	2014 Office Equipment	2,500.00

SPECIAL DISTRICTS

FROM:	150.8160.4468	Compost	\$2,700.00
TO:	150.8160.2209	Office Equipment	\$2,700.00

HIGHWAY

FROM:	300.5110.4186	Topsoil	\$11,000.00
	300.5110.4207	GPS	4,531.59
	300.5140.4291	Trees	9,968.41
	300.5140.4297	Tree Maintenance	5,000.00
TO:	300.5130.4462	Parts & Maintenance	\$15,500.00
	300.5142.4029	Salt	15,000.00

CDBG

FROM:	700.1011.0600	Housing Rehab.-Single Family	\$105,173.39
TO:	700.1014.0665	Senior Citizens Van Acquisition	\$105,173.39

PART TOWN

FROM:	800.3620.4191	Miscellaneous	\$1,300.00
TO:	800.3620.4001	Office Supplies	\$1,300.00

RESULT:	ADOPTED [UNANIMOUS]
MOVER:	Gerald Kaminski, Councilmember
SECONDER:	James P. Rogowski, Councilmember
AYES:	James P. Rogowski, Gerald Kaminski, Diane Benczkowski, Timothy J. Meyers
ABSENT:	Mary Holtz



2. RESOLUTION 2014-642

Warrant

Sponsored By: Councilmember Kaminski, Councilmember Rogowski

BE IT RESOLVED, that the following Vouchers & Warrants submitted to the Town of Cheektowaga prior to December 15, 2014 are hereby approved and made part hereof;

GENERAL FUND	\$10,213,396.81
RISK RETENTION FUND	855,335.99
NYS HOME PROGRAM	0.00
DEBT	0.00
HUD HOUSING REHABILITATION FUND	11,054.00
SPECIAL DISTRICTS FUND	1,728,463.82
HIGHWAY FUND	2,141,400.75
CAPITAL FUND	176,866.72
TRUST & AGENCY FUND	5,933.70
HUD CDBG FUND	37,034.88
PART TOWN FUND	285,552.43
NYS AFFORDABLE HOUSING	1,911.00
	<hr/>
	\$15,456,950.10

RESULT:	ADOPTED [UNANIMOUS]
MOVER:	Gerald Kaminski, Councilmember
SECONDER:	James P. Rogowski, Councilmember
AYES:	James P. Rogowski, Gerald Kaminski, Diane Benczkowski, Timothy J. Meyers
ABSENT:	Mary Holtz



3. RESOLUTION 2014-643

Negative SEQR Declaration - 2525-2535 Walden Avenue

Sponsored By: Councilmember Meyers, Councilmember Kaminski

WHEREAS, pursuant to the Environmental Impact Review Ordinance of the Town of Cheektowaga, the Environmental Advisory Committee ("EAC") reviews various applications for site plans, rezonings, special permits, etc. and renders its recommendation concerning the environmental significance of such application, AND

WHEREAS, an application was submitted by Benderson Development Company, LLC for the rezoning of part of 2525 and 2535 Walden Avenue from M1- Light Manufacturing to CM-General Commercial to accommodate the redevelopment of all of 2525 and 2535 Walden Avenue, AND

WHEREAS, the redevelopment project will include the demolition of an existing 91,655 sf warehouse building, construction of a new 78,486 sf warehouse building, construction of 13,090 s.f office building and the conversion of an existing 21,041 sf warehouse building for retail use, AND

WHEREAS, the Town Board, pursuant to the Environmental Impact Review Ordinance of the Town of Cheektowaga, is designated the Lead Agency, AND

WHEREAS, since the Town Board is the Lead Agency, it must affirm, modify or reject any recommendations submitted to it by the Advisory Committee, AND

WHEREAS, the Town of Cheektowaga Planning Board recommended approval of the rezoning request and site plan at their meetings of June 12, 2014 and September 11, 2014 respectively, AND

WHEREAS, the Environmental Advisory Committee at its meetings held on September 17, 2014 recommended a determination of non-significance, AND

WHEREAS, this Town Board has reviewed the application submitted and the recommendations made by the Environmental Advisory Committee and the Planning Board NOW, THEREFORE, BE IT

RESOLVED, that this Town Board determines that the project will not have a significant effect on the environment and therefore issues a Negative Declaration for purposes of the State Environmental Quality Review Act (SEQRA).

RESULT:	ADOPTED [UNANIMOUS]
MOVER:	Timothy J. Meyers, Councilmember
SECONDER:	Gerald Kaminski, Councilmember
AYES:	James P. Rogowski, Gerald Kaminski, Diane Benczkowski, Timothy J. Meyers
ABSENT:	Mary Holtz



4. RESOLUTION 2014-644

Accept Site Plan- 2525 and 2535 Walden Avenue

Sponsored By: Councilmember Benczkowski, Councilmember Rogowski

WHEREAS, pursuant to the Zoning Law of the Town of Cheektowaga, the Planning Board reviews various development review applications for site plans, rezonings, special permits and realty subdivisions and renders its recommendation concerning the compatibility of such application with the zoning regulations, the Town Master Plan and neighborhood character, AND

WHEREAS, the Town Board, pursuant to section 260-47.1C of the Zoning Law of the Town of Cheektowaga is vested with the authority to approve site plans and modify or reject any recommendation submitted to it by its advisory committees, AND

WHEREAS, Benderson Development Co., LLC submitted a development review application for the re-development of 2525 and 2535 Walden Avenue, AND

WHEREAS, the redevelopment project will include the demolition of an existing 91,655 sf warehouse building, construction of a new 78,486 sf warehouse building, construction of 13,090 s.f office building and the conversion of an existing 21,041 sf warehouse building for retail use, AND

WHEREAS, the Town of Cheektowaga Planning Board, reviewed and commented on the Application at their meetings of June 12, 2014 and September 11, 2014 respectively and have recommended approval thereof, NOW THEREFORE BE IT,

RESOLVED, that pursuant to Section 260-47-1 of the Code of the Town of Cheektowaga and Section 274-a of New York State Town Law that this Town Board approves the proposed site plan subject to:

1. The Town Engineer reviewing/approving the drainage/grading plan.

RESULT:	ADOPTED [UNANIMOUS]
MOVER:	Diane Benczkowski, Councilmember
SECONDER:	James P. Rogowski, Councilmember
AYES:	James P. Rogowski, Gerald Kaminski, Diane Benczkowski, Timothy J. Meyers
ABSENT:	Mary Holtz



5. RESOLUTION 2014-645

Accept Site Plan- 2760 Union Road Olive Tree Restaurant

Sponsored By: Councilmember Benczkowski, Councilmember Rogowski

WHEREAS, pursuant to the Zoning Law of the Town of Cheektowaga, the Planning Board reviews various development review applications for site plans, rezonings, special permits and realty subdivisions and renders its recommendation concerning the compatibility of such application with the zoning regulations, the Town Master Plan and neighborhood character, AND

WHEREAS, the Town Board, pursuant to section 260-47.1C of the Zoning Law of the Town of Cheektowaga is vested with the authority to approve site plans and modify or reject any recommendation submitted to it by its advisory committees, AND

WHEREAS, Sutton Architecture on behalf of Geroge N. Aronis submitted a development review application for the construction of building additions totaling 1,100 s.f. in area to an existing restaurant at 2760 Union Road at, AND

WHEREAS, the Town of Cheektowaga Planning Board, reviewed and commented on the Application at their meeting of November 13, 2014 and have recommended approval thereof, NOW THEREFORE BE IT,

RESOLVED, that pursuant to Section 260-47-1 of the Code of the Town of Cheektowaga and Section 274-a of New York State Town Law that this Town Board approves the proposed site plan.

RESULT:	TABLED [UNANIMOUS] Next: 1/5/2015 6:45 PM
MOVER:	Diane Benczkowski, Councilmember
SECONDER:	Timothy J. Meyers, Councilmember
AYES:	James P. Rogowski, Gerald Kaminski, Diane Benczkowski, Timothy J. Meyers
ABSENT:	Mary Holtz



6. RESOLUTION 2014-646

Approve Rezoning of Part of 2525 and 2535 Walden Avenue

Sponsored By: Councilmember Benczkowski, Councilmember Meyers

WHEREAS, Benderson Development Company, LLC petitioned for a rezoning from M1-Light Manufacturing District to CM-General Commercial District for a portion of property owned by Benderson 85-1 Trust and 2525 Walden Associates and located at 2525 and 2535 Walden Avenue, Cheektowaga, New York, which property is described in the attached legal description, for the re-development of an existing warehouse/office development to include: the demolition of an existing warehouse building and the re-utilization of an existing 21,041 square foot warehouse building for retail sales, and

WHEREAS, a public hearing on such petition was held before this Town Board on the 20th day of October, 2014 at 6:45 P.M., after publication and service of the notices required by the provisions of the Code of the Town of Cheektowaga ("Zoning Law"), and the Town Law; and all interested parties were given an opportunity to be heard at such hearing, and

WHEREAS, the Cheektowaga Planning Board has reviewed such application and has recommended approval thereof, and

WHEREAS, this Town Board previously issued a Negative Declaration under SEQRA and the Town Environmental Impact Review Ordinance for this rezoning, NOW, THEREFORE, BE IT

RESOLVED, that the application of Benderson Development Company, LLC for the rezoning from M1-Light Manufacturing District to CM-General Commercial District of the property described in the attached legal description be and the same is hereby approved, subject to the following condition:

1. Any future additions to the development or site plan must be resubmitted to the Town Board to determine that the addition is substantially in agreement with the intent of this rezoning

, and BE IT FURTHER

RESOLVED, that the Zoning Map and Law of the Town of Cheektowaga be amended in accordance with the above.

+++++

LEGAL DESCRIPTION

All that tract or parcel of land situate in Town of Cheektowaga, County of Erie, and State of New York, ALL THAT TRACT OR PARCEL OF LAND situate in the Town of Cheektowaga, County of Erie and State of New York, being part of Lot No. 11, Township 11, Range 7 of the Holland Land Company's Survey, bounded and described as follow:

Beginning at the point of intersection of the south line of Walden Avenue Extension with the west line of the lands conveyed to Latrobe Steel Company by deed dated July 25, 1955 and recorded in the Erie County Clerk's Office in Liber 5795 of Deeds at page 461; Thence S01°04'46"E along said west line of the lands conveyed by Deed aforesaid, a distance of 345.98 feet to a point; Thence S88°55'14"W, a distance of 333.06 feet to a point; Thence N01°04'46"W parallel with the east line of premises herein described, a distance of 291.32 feet to the south line of Walden Avenue Extension; Thence N79°36'03"E along the south line of Walden Avenue Extension, a distance of 337.52 feet to the point or place of beginning.

Parcel containing 2.436 acres of land, more or less.

RESULT:	ADOPTED [UNANIMOUS]
MOVER:	Diane Benczkowski, Councilmember
SECONDER:	Timothy J. Meyers, Councilmember
AYES:	James P. Rogowski, Gerald Kaminski, Diane Benczkowski, Timothy J. Meyers
ABSENT:	Mary Holtz



7. RESOLUTION 2014-647

Approval of Change Order No. 2 - Sewer Maintenance Building Addition and Renovation Project

Sponsored By: Councilmember Kaminski, Councilmember Meyers

WHEREAS, the contract for the Sewer Maintenance Building Addition and Renovation Project was awarded by Town Board Resolution dated May 19, 2014 to SM Hayes, LLC, Construction Services, 174 Anderson Place, Buffalo, New York 14222 in the amount of \$506,900.00, AND

WHEREAS, the Project Architect, Aurora Architectural, and the Town Engineer have recommended the approval of Change Order No. 2 which provides for several additions and deletions beyond the original scope of the project as further detailed in the change order document, NOW, THEREFORE, BE IT

RESOLVED, that Change Order No. 2 for the Sewer Maintenance Building Addition and Renovation Project in the amount of \$8,260.87 as an addition to the contract for additional site work, which will be offset by the contract contingency allowance, be and hereby is approved, AND, BE IT FURTHER

RESOLVED, that the Supervisor is hereby authorized and directed to execute said Change Order No. 2 on behalf of this Town Board.

RESULT:	ADOPTED [UNANIMOUS]
MOVER:	Gerald Kaminski, Councilmember
SECONDER:	Timothy J. Meyers, Councilmember
AYES:	James P. Rogowski, Gerald Kaminski, Diane Benczkowski, Timothy J. Meyers
ABSENT:	Mary Holtz



8. RESOLUTION 2014-648

Establish Holidays for 2015

Sponsored By: Councilmember Kaminski, Councilmember Rogowski

BE IT RESOLVED, that the following holidays shall be observed by the Town of Cheektowaga in 2015:

New Year's Day	January 1, 2015	Thursday
Martin Luther King, Jr. Day	January 19, 2015	Monday
President's Day	February 16, 2015	Monday
Good Friday	April 3, 2015	Friday
Memorial Day	May 25, 2015	Monday
Independence Day	July 3, 2015	Friday
Labor Day	September 7, 2015	Monday
Columbus Day	October 12, 2015	Monday
Election Day	November 3, 2015	Tuesday
Veterans Day	November 11, 2015	Wednesday
Thanksgiving Day	November 26, 2015	Thursday
Day After Thanksgiving	November 27, 2015	Friday
Christmas Eve	December 24, 2015	Thursday
Christmas Day	December 25, 2015	Friday

RESULT:	ADOPTED [UNANIMOUS]
MOVER:	Gerald Kaminski, Councilmember
SECONDER:	James P. Rogowski, Councilmember
AYES:	James P. Rogowski, Gerald Kaminski, Diane Benczkowski, Timothy J. Meyers
ABSENT:	Mary Holtz



9. RESOLUTION 2014-649

Notice To Bidders 2015 Portable Chemical Toilets (Bid 2014-36)

Sponsored By: Councilmember Rogowski, Councilmember Kaminski

WHEREAS, The Town of Cheektowaga, Facilities Department, Parks Division, utilizes Portable Chemical Toilets at various locations to service their recreational activities and Special Events (Bid 2014-36), NOW BE IT

RESOLVED, that the Town Clerk be directed to publish a Notice To Bidders for the Leasing and Servicing of Portable Chemical Toilets, AND BE IT FURTHER

RESOLVED, that specifications for said Leasing and Servicing of Portable Chemical Toilets be obtained from the Town Clerk's Office in Cheektowaga Town Hall, AND BE IT FURTHER

RESOLVED, that sealed bids will be received on the 31st day of December, 2014 at 11:00 AM Eastern Standard Time at a Public bid opening to be held in the Council Chambers at Cheektowaga Town Hall.



Notice to Bidders

Sealed proposals will be received by the Town Clerk on December 31, 2014 at 11:00 AM Eastern Standard Time at the Town Hall, 3301 Broadway, for Leasing and Servicing of Portable Chemical Toilets for the year 2015 (Bid 2014-36).

Information for bidders and specifications may be obtained from the Town Clerk at her office in Town Hall.

The Town Board reserves the right to consider informal any bid not prepared and submitted in accordance with the provisions of the specifications and contract documents and may waive any informalities, make an award to other than the low bidder should it be in the best interest of the Town, or reject any or all bids.

By Order of the Town Board of the Town of Cheektowaga, Erie County, New York.

Alice Magierski, Town Clerk

Date: December 15, 2014

RESULT: **ADOPTED [UNANIMOUS]**
MOVER: James P. Rogowski, Councilmember
SECONDER: Gerald Kaminski, Councilmember
AYES: James P. Rogowski, Gerald Kaminski, Diane Benczkowski, Timothy J. Meyers
ABSENT: Mary Holtz



10. RESOLUTION 2014-650

Notice to Bidders - Up to Two 2014 or Newer Ford Escape SE, SUV, or Equal (BID #2014-37 CD)

Sponsored By: Councilmember Kaminski, Councilmember Benczkowski

WHEREAS, it is in order that a Notice to Bidders be advertised for the purchase of up to two (2) new and unused 2014 or newer Ford Escape SE, SUV, or equal (Bid 2014-37 CD), NOW, THEREFORE, BE IT

RESOLVED, that the Town Clerk be and hereby is directed to publish a Notice to Bidders for the purchase of said vehicle, said notice to be published in the CHEEKTOWAGA BEE, AND, BE IT FURTHER

RESOLVED, that sealed bids will be received on the 31st day of December, 2014 at 11:00 A.M., Local Time, at a public bid opening to be held in the Council Chambers in the Cheektowaga Town Hall.



NOTICE TO BIDDERS

Sealed proposals will be received by the Town of Cheektowaga on December 31, 2014 at 11:00 A.M., Local Time, at the Town Hall, corner of Broadway and Union Roads, for the purchase of up to two (2) new and unused 2014 or newer Ford Escape SE, SUV, or equal (Bid 2014-37 CD).

Information for bidders and specifications may be obtained from the Town Clerk at her office in Town Hall.

The Town Board reserves the right to consider informal any bid not prepared and submitted in accordance with the provisions of the specifications and contract documents, and may waive any informalities, make an award to other than the low bidder, should it be in the best interest of the Town, or reject any or all bids.

By order of the Town Board of the Town of Cheektowaga, Erie County, New York.

Alice Magierski, Town Clerk

DATED: December 15, 2014

PUBLISH: December 18, 2014

RESULT:	ADOPTED [UNANIMOUS]
MOVER:	Gerald Kaminski, Councilmember
SECONDER:	Diane Benczkowski, Councilmember
AYES:	James P. Rogowski, Gerald Kaminski, Diane Benczkowski, Timothy J. Meyers
ABSENT:	Mary Holtz



11. RESOLUTION 2014-651

Authorize Supervisor to Execute Agreement for Telecommunications Services

Sponsored By: Councilmember Rogowski, Councilmember Meyers

WHEREAS, the agreement with PAETEC and its successor for the provision of local, long distance, international communications and data services to all Town buildings, as well as service and maintenance for all telecommunications equipment required therein has expired; and

WHEREAS, Time Warner Cable, in concert with Seger Communications Inc. ("SCI"), was awarded a New York State contract (OGS Contract # PS63596, Group # 77017, Award # 20268), through the Office of General Services to supply comprehensive telecommunications services to local governments in New York State; and

WHEREAS, the Town has met with representatives of Time Warner Cable and SCI and they have submitted a proposal to the Town to provide these telecommunications services, including the upgrade, modification, or enhancement to existing equipment, and to provide service and maintenance for same, all as more fully set forth in the Service Agreement/Terms and Conditions; and

WHEREAS, it is advantageous to the Town to enter into an agreement with Time Warner Cable for the above services; NOW, THEREFORE, BE IT

RESOLVED, that this Town Board hereby authorizes the Supervisor to execute the necessary contracts and all other necessary documents with Time Warner Cable and/or Seger Communications Inc. ("SCI") for the aforementioned telecommunications services, equipment, maintenance and service, at a cost not to exceed \$7,189.52 per month for thirty-six (36) months, together with an additional approximate \$2,800.00 per month for Regulatory Recovery Fees, Federal Line Charges, etc., (excluding ant taxes), the actual amount of which will be determined upon finalization of the order; and BE IT FURTHER

RESOLVED, that funds for telecommunications services, equipment, and maintenance of same shall be appropriated through budget line item number 0100-1625-4202.

RESULT:	ADOPTED [UNANIMOUS]
MOVER:	James P. Rogowski, Councilmember
SECONDER:	Timothy J. Meyers, Councilmember
AYES:	James P. Rogowski, Gerald Kaminski, Diane Benczkowski, Timothy J. Meyers
ABSENT:	Mary Holtz



12. RESOLUTION 2014-652

Authorize Supervisor to Sign Agreement with SJB Services, Inc. for Special Inspections at the Firing Range Shelter (BID # 2014-29)

Sponsored By: Councilmember Benczkowski, Councilmember Kaminski

WHEREAS, the contract for the construction of a Firing Range Shelter was awarded by Town Board Resolution dated September 15, 2014 to Building Innovation Group, LLC, AND

WHEREAS, the New York State Department of State, Division of Code Enforcement and Administration, requires special inspections during the duration of construction to be provided by an independent firm engaged by the owner, said testing to include, but not be limited to, excavation and backfilling, reinforced and pre-stressed concrete, high strength bolting and welding of structural steel components, AND

WHEREAS, the professional testing agency of SJB Services, Inc., (said firm performed the initial soil testing) has submitted a proposal to provide aforesaid special inspections for the not to exceed price of \$10,000, NOW, THEREFORE, BE IT

RESOLVED, that the proposal from SJB Services, Inc., 5167 South Park Avenue, Hamburg, New York 14075 is hereby approved and accepted, AND, BE IT FURTHER

RESOLVED, that the Supervisor, on behalf of this Town Board, is hereby directed and authorized to sign said agreement with SJB Services, Inc. for the provision of professional services in the field of Special Inspections in an amount not to exceed \$10,000 which shall be chargeable to Account #500-1440-2063-5227.

RESULT:	ADOPTED [UNANIMOUS]
MOVER:	Diane Benczkowski, Councilmember
SECONDER:	Gerald Kaminski, Councilmember
AYES:	James P. Rogowski, Gerald Kaminski, Diane Benczkowski, Timothy J. Meyers
ABSENT:	Mary Holtz



13. RESOLUTION 2014-653

Authorization to Purchase 13 Two-Way Radios

Sponsored By: Councilmember Benczkowski, Councilmember Kaminski

WHEREAS, the Police Department is in need of thirteen (13) Motorola APX 4000 UHFR1 MHZ Model 2 Portable radios to replace current police radios that are reaching end of life and are cost-prohibitive to be repaired; AND

WHEREAS, Motorola Solutions Incorporated, 13108 Collections Center Drive, Chicago, Illinois 60693 has submitted a quotation for radio equipment and technical service which are covered under New York State Contract PT62495 (equipment) and PS62496 (service); AND

WHEREAS, the total cost for the radio equipment and technical service will be \$25,234.50; AND

WHEREAS, the Cheektowaga Police Department will pay for the thirteen (13) Motorola APX 4000 UHFR1 MHZ Model 2 portable radios and technical service out of Communications budget line 100-3020-2513; NOW, THEREFORE, BE IT

RESOLVED, that the Cheektowaga Town Board hereby authorizes the Cheektowaga Police Department to purchase thirteen (13) portable radios and technical service.

RESULT:	ADOPTED [UNANIMOUS]
MOVER:	Diane Benczkowski, Councilmember
SECONDER:	Gerald Kaminski, Councilmember
AYES:	James P. Rogowski, Gerald Kaminski, Diane Benczkowski, Timothy J. Meyers
ABSENT:	Mary Holtz



14. RESOLUTION 2014-654

Approve Purchase of One (1) Tandem Axle Cab/Chassis with Dump Body and Plow Equipment

Sponsored By: Councilmember Kaminski, Councilmember Rogowski

WHEREAS, the Highway Department's sterling tandem dump plow truck #204 had an electrical fire overnight on the 22nd of May causing the vehicle to be a total loss, AND

WHEREAS, the Highway Department has requested authorization to purchase one (1) 2015 T470 Tandem Axle Cab/Chassis with Dump Body and plow equipment, as specified in County of Onondaga Division of Purchase Contract, Bid Ref. #7823, contract period: June 24, 2013 through June 23, 2018, AND

WHEREAS, funds for said purchase have been budgeted and are available under account number 300-5130-2407, NOW THEREFORE BE IT,

RESOLVED, that the Town Board hereby authorizes the purchase of one (1) 2014 T470 Tandem Axle Cab/Chassis with Dump Body and plow equipment in the amount of \$209,122.00 from:

Kenworth Northeast Group
100 Commerce Drive
Buffalo, NY 14218

RESULT:	ADOPTED [UNANIMOUS]
MOVER:	Gerald Kaminski, Councilmember
SECONDER:	James P. Rogowski, Councilmember
AYES:	James P. Rogowski, Gerald Kaminski, Diane Benczkowski, Timothy J. Meyers
ABSENT:	Mary Holtz



15. RESOLUTION 2014-655

Approve Purchase of (2) 2014 Toro Zero Turns

Sponsored By: Councilmember Rogowski, Councilmember Kaminski

WHEREAS, the Facilities Department, Parks Division, has requested authorization to purchase two (2) 2014 Toro Z Master Zero Turns with 60" deck as specified in New York State OGS Contract PC 64358B, AND

WHEREAS, funds for said purchase have been budgeted and are available from account number 100-7110-2304, NOW, THEREFORE BE IT

RESOLVED, that the Town Board hereby authorizes the purchase of two (2) 2014 Toro Z Master Zero Turns with 60" deck in the amount of \$18,043.20 from:

Grassland Equipment
892-898 Troy-Schenectady Road
Latham, New York 12110

(This amount corresponds with the trade in of Toro Z Turn: Serial #: 310000371 and Toro Z Turn: Serial #: 290001246.)

Savilles Outdoor Power Equipment
9900 Taylor Road
Orchard Park, NY 14127

RESULT:	ADOPTED [UNANIMOUS]
MOVER:	James P. Rogowski, Councilmember
SECONDER:	Gerald Kaminski, Councilmember
AYES:	James P. Rogowski, Gerald Kaminski, Diane Benczkowski, Timothy J. Meyers
ABSENT:	Mary Holtz



16. RESOLUTION 2014-656

Approve Purchase of 2015 Ford F250 Pick Up Truck

Sponsored By: Councilmember Rogowski, Councilmember Kaminski

WHEREAS, the Facilities Department, Parks Division, have requested authorization to purchase one (1) 2015 Ford F250 4x4 pick-up truck, as specified in New York State OGS Contracts PC66390, Item Number Lot 1-Item 10 AND

WHEREAS, funds for said purchase have been budgeted and are available under account numbers 100-7110-2303 and 100-7110-2304, NOW, THEREFORE BE IT,

RESOLVED, that the Town Board hereby authorizes the purchase of one (1) 2015 Ford F250 4x4 pick-up truck, in the amount of \$23,564.30 From:

Henderson Ford
810 Ridge Road
Webster, NY 14580

RESULT:	ADOPTED [UNANIMOUS]
MOVER:	James P. Rogowski, Councilmember
SECONDER:	Gerald Kaminski, Councilmember
AYES:	James P. Rogowski, Gerald Kaminski, Diane Benczkowski, Timothy J. Meyers
ABSENT:	Mary Holtz



17. RESOLUTION 2014-657

Approve Purchase of Ford F250 Pick Up Truck With Plow

Sponsored By: Councilmember Rogowski, Councilmember Kaminski

WHEREAS, the Facilities Department, Building & Grounds Division, have requested authorization to purchase one (1) 2015 Ford F250 4x4 pick-up truck with 8 1/2' Fisher Extreme V Plow, as specified in New York State OGS Contracts PC66390, Item Number Lot 1-Item 10 AND

WHEREAS, funds for said purchase have been budgeted and are available under account number 100-1625-2303 , NOW, THEREFORE BE IT,

RESOLVED, that the Town Board hereby authorizes the purchase of one (1)2015 Ford F250 4x4 pick-up truck, with 8 1/2' Fisher Extreme V Plow in the amount of \$29,215.73 From:

Henderson Ford
810 Ridge Road
Webster, NY 14580

RESULT:	ADOPTED [UNANIMOUS]
MOVER:	James P. Rogowski, Councilmember
SECONDER:	Gerald Kaminski, Councilmember
AYES:	James P. Rogowski, Gerald Kaminski, Diane Benczkowski, Timothy J. Meyers
ABSENT:	Mary Holtz



18. RESOLUTION 2014-658

Unsafe-Unsecured/128 North Creek Dive

Sponsored By: Councilmember Kaminski, Councilmember Benczkowski

WHEREAS, Town of Cheektowaga Law for the Administration and Enforcement of the Codes of New York State; and the Property Maintenance Code of New York State require that all vacant structures and premises shall be maintained in clean, safe, secure and sanitary conditions so as not to cause a blighting problem or adversely affect the public health or safety and all nuisances abated, AND

WHEREAS, the Town of Cheektowaga has received notification of an unsafe structure and premises located at 128 North Creek Drive, Cheektowaga, New York SBL# 103.05-12-21 That is a danger to the safety of others, and records kept by the Assessors Office identify Marianne Anderson, 128 North Creek Drive, Cheektowaga, New York 14225, as the owner AND

WHEREAS, an inspection of such premises was conducted at 128 North Creek Drive, by the Housing and Neighborhood Preservation Office, AND

WHEREAS, such inspection found the premises to be deteriorated, vacant, a hazard, and a danger to the safety and well being of others, AND

WHEREAS, the Town of Cheektowaga Housing and Neighborhood Preservation Office properly notified the property owner in accordance with the Town of Cheektowaga Law for the Administration and Enforcement of the Codes of New York State, and the owner failed to take actions to safeguard the premises, AND

WHEREAS, these conditions require the Town of Cheektowaga Housing and Neighborhood Preservation Office to take immediate steps to safeguard the premises to protect the health and safety of others and abate all nuisances, NOW, THEREFORE BE IT

RESOLVED, that pursuant to Section 70-7A.(5) and Section 70-8 of the Town of Cheektowaga Law for the Administration and Enforcement of the Codes of New York State that the vacant structure premises be safeguarded and all nuisances abated; and all costs incurred be assessed against the property hereinbefore described.

RESULT:	ADOPTED [UNANIMOUS]
MOVER:	Gerald Kaminski, Councilmember
SECONDER:	Diane Benczkowski, Councilmember
AYES:	James P. Rogowski, Gerald Kaminski, Diane Benczkowski, Timothy J. Meyers
ABSENT:	Mary Holtz



19. RESOLUTION 2014-659

Unsafe-Unsecured/49 Pinehurst Avenue

Sponsored By: Councilmember Kaminski, Councilmember Benczkowski

WHEREAS, Town of Cheektowaga Law for the Administration and Enforcement of the Codes of New York State; and the Property Maintenance Code of New York State require that all vacant structures and premises shall be maintained in clean, safe, secure and sanitary conditions so as not to cause a blighting problem or adversely affect the public health or safety and all nuisances abated, AND

WHEREAS, the Town of Cheektowaga has received notification of an unsafe structure and premises located at 49 Pinehurst Avenue, Cheektowaga, New York SBL# 91.19-6-21 That is a danger to the safety of others, and records kept by the Assessors Office identify Jacqueline Acanfora, 13 Nason Pkwy, Buffalo, New York 14218, as the owner AND

WHEREAS, an inspection of such premises was conducted at 49 Pinehurst Avenue, by the Housing and Neighborhood Preservation Office, AND

WHEREAS, such inspection found the premises to be deteriorated, vacant, a hazard, and a danger to the safety and well being of others, AND

WHEREAS, the Town of Cheektowaga Housing and Neighborhood Preservation Office properly notified the property owner in accordance with the Town of Cheektowaga Law for the Administration and Enforcement of the Codes of New York State, and the owner failed to take actions to safeguard the premises, AND

WHEREAS, these conditions require the Town of Cheektowaga Housing and Neighborhood Preservation Office to take immediate steps to safeguard the premises to protect the health and safety of others and abate all nuisances, NOW, THEREFORE BE IT

RESOLVED, that pursuant to Section 70-7A.(5) and Section 70-8 of the Town of Cheektowaga Law for the Administration and Enforcement of the Codes of New York State that the vacant structure premises be safeguarded and all nuisances abated; and all costs incurred be assessed against the property hereinbefore described.

RESULT:	ADOPTED [UNANIMOUS]
MOVER:	Gerald Kaminski, Councilmember
SECONDER:	Diane Benczkowski, Councilmember
AYES:	James P. Rogowski, Gerald Kaminski, Diane Benczkowski, Timothy J. Meyers
ABSENT:	Mary Holtz



20. RESOLUTION 2014-660

Unsafe-Unsecured/15 Crescent Court

Sponsored By: Councilmember Kaminski, Councilmember Benczkowski

WHEREAS, Town of Cheektowaga Law for the Administration and Enforcement of the Codes of New York State; and the Property Maintenance Code of New York State require that all vacant structures and premises shall be maintained in clean, safe, secure and sanitary conditions so as not to cause a blighting problem or adversely affect the public health or safety and all nuisances abated, AND

WHEREAS, the Town of Cheektowaga has received notification of an unsafe structure and premises located at 15 Crescent Court, Cheektowaga, New York SBL# 102.06-2-2 that is a danger to the safety of others, and records kept by the Assessors Office identify Darlene Egleston, 37 Bramhill Court, East Amherst, New York 14051, as the owner AND

WHEREAS, an inspection of such premises was conducted at 15 Crescent Court, by the Housing and Neighborhood Preservation Office, AND

WHEREAS, such inspection found the premises to be deteriorated, vacant, a hazard, and a danger to the safety and well being of others, AND

WHEREAS, the Town of Cheektowaga Housing and Neighborhood Preservation Office properly notified the property owner in accordance with the Town of Cheektowaga Law for the Administration and Enforcement of the Codes of New York State, and the owner failed to take actions to safeguard the premises, AND

WHEREAS, these conditions require the Town of Cheektowaga Housing and Neighborhood Preservation Office to take immediate steps to safeguard the premises to protect the health and safety of others and abate all nuisances, NOW, THEREFORE BE IT

RESOLVED, that pursuant to Section 70-7A.(5) and Section 70-8 of the Town of Cheektowaga Law for the Administration and Enforcement of the Codes of New York State that the vacant structure premises be safeguarded and all nuisances abated; and all costs incurred be assessed against the property hereinbefore described.

RESULT:	ADOPTED [UNANIMOUS]
MOVER:	Gerald Kaminski, Councilmember
SECONDER:	Diane Benczkowski, Councilmember
AYES:	James P. Rogowski, Gerald Kaminski, Diane Benczkowski, Timothy J. Meyers
ABSENT:	Mary Holtz



21. RESOLUTION 2014-661

Registration for the New York State Sewage Pollution Right to Know Act

Sponsored By: Councilmember Kaminski, Councilmember Meyers

WHEREAS, New York State passed the Sewage Pollution Right to Know Act (SPRTK), Environmental Conservation Law 17-0826-A, which requires publicly owned treatment works (POTWs) and operators of publicly owned sewer systems (POSSs) to report releases of untreated or partially treated sewage to the New York State Department of Environmental Conservation (NYSDEC), the local County and State Departments of Health, adjoining municipalities and the general public on a timely basis. This law became effective on May 1, 2013, AND

WHEREAS, the NYSDEC has proposed regulations to implement SPRTKs which require POSSs to register with the NYSDEC, AND

WHEREAS, to assist POSSs and POTWs with complying with reporting requirements the NYSDEC has worked with the New York Department of Homeland Security and Emergency Services (DHSES) to modify the NY-Alert System to accommodate the reporting of sewage releases by POTW and POSSs. The NY-Alert System is being provided at no cost to the reporting municipalities, authorities, and agencies. The NY-Alert System will be available for use by January 15, 2015, AND

WHEREAS, the Town owns and operates its own POSS, AND

WHEREAS, the new regulation requires POTW and POSSs to register with the NYSDEC by completing and signing the attached POSS Notification Registration Application Forms, NOW, THEREFORE, BE IT

RESOLVED, that the Supervisor, on behalf of this Town Board, is hereby directed to sign the POSS Notification Registration Forms, AND, BE IT FURTHER

RESOLVED, that the Supervisor's signature grants authorization to designated employees of the Main Pump Station and the Sewer Maintenance Department to submit required reports to the NY-Alert System.

RESULT:	ADOPTED [UNANIMOUS]
MOVER:	Gerald Kaminski, Councilmember
SECONDER:	Timothy J. Meyers, Councilmember
AYES:	James P. Rogowski, Gerald Kaminski, Diane Benczkowski, Timothy J. Meyers
ABSENT:	Mary Holtz



22. RESOLUTION 2014-662

Retain Nussbaumer & Clarke, Inc. for Design Development of Beach and Vegola Sanitary Relief Sewer Project

Sponsored By: Councilmember Kaminski, Councilmember Meyers

WHEREAS, the Town has been issued an Order on Consent from the New York State Department of Environmental Conservation (NYSDEC) to abate wet weather sanitary sewer overflow (SSO) activity throughout its wastewater collection system, AND

WHEREAS, the Town Engineering Department has developed a proposed project to eliminate an SSO currently located at Beach Road and Winston Avenue and another at Winston Avenue and Vegola Avenue by constructing a gravity relief sewer of approximately 7400 L.F. between Winston Avenue and Nokomis Park, AND

WHEREAS, in order to proceed with said project there is a need to perform a detailed topographic survey and prepare a preliminary design, engineer's report, detailed cost estimate and to coordinate design approval with the NYSDEC, NOW, THEREFORE, BE IT

RESOLVED, that the proposal of Nussbaumer & Clarke, Inc. dated October 24, 2014 to the Town Engineer for professional services associated with the design, bid and construction phases of this project as detailed in the aforesaid proposal is accepted and approved, AND, BE IT FURTHER

RESOLVED, that the Supervisor, on behalf of this Town Board, is hereby directed and authorized to sign the agreement with Nussbaumer & Clarke, Inc. for the provision of said professional services, AND, BE IT FURTHER

RESOLVED, that the cost of said professional services to be billed on an hourly basis not to exceed \$380,000.00 shall be chargeable to an account designated by the Director of Finance.

RESULT:	ADOPTED [UNANIMOUS]
MOVER:	Gerald Kaminski, Councilmember
SECONDER:	Timothy J. Meyers, Councilmember
AYES:	James P. Rogowski, Gerald Kaminski, Diane Benczkowski, Timothy J. Meyers
ABSENT:	Mary Holtz



23. RESOLUTION 2014-663

2015 Minimum Wage Increase

Sponsored By: Councilmember Rogowski, Councilmember Kaminski

WHEREAS, the New York State Legislature has approved minimum wage increase in 2014, 2015, and 2016 and

WHEREAS, the second of three increases becomes effective January 1, 2015, NOW THEREFORE

RESOLVED that the following individuals be and hereby are elevated as follows so as to comply with the new minimum wage law as it affects the existing workforce pay structure of those earning less than \$8.75 per hour (regular part-time/part time):

Jenna Brewer	-	\$8.75
Grace Dalton	-	\$8.75
Kristina DiBlasio	-	\$8.75
Brittany Donovan	-	\$8.75
Jessica Elston	-	\$8.75
Jessica Gaffney	-	\$8.75
Daniel Golinski	-	\$8.75
Leah Hoffman	-	\$8.75
Verliddia Jones	-	\$8.75
Kellie Kaminski	-	\$8.75
Kourtney Killian	-	\$8.75
Alexandria Makowski	-	\$8.75
Michael Jerome McGregor	-	\$8.75
Lennox Melin	-	\$8.75
Bailey Michalski	-	\$8.75
Melissa Owczarzak	-	\$8.75
Anthone' Proctor	-	\$8.75
Natalie Stack	-	\$8.75
Janelle Thompson	-	\$8.75
Eric Wilson	-	\$8.75
Mariah Wilson	-	\$8.75
Molly Wittig	-	\$8.75
Gillian Wittig	-	\$8.75
Brian Wroblewski	-	\$8.75
Kelly Zaky	-	\$8.75
Jared Bulinski	-	\$8.90
Ashley Carney	-	\$8.90
Eric Farinacci	-	\$8.90
Joshua Graser	-	\$8.90
Dakota Herkey	-	\$8.90
Allison Herman	-	\$8.90
Danielle Keller	-	\$8.90
Dean Lach	-	\$8.90
Kelly Mayer	-	\$8.90

Elizabeth Meyerhofer	-	\$8.90
Tyler Nosal	-	\$8.90
Karisa Poczciwinski	-	\$8.90
Carolyn Reczek	-	\$8.90
Derek Schenk	-	\$8.90
Jenna Soldaczewski	-	\$8.90
Joseph Swierczynski	-	\$8.90
Rebecca Szyjka	-	\$8.90
Ryan Trapper	-	\$8.90
Theresa Tripi	-	\$8.90
Mikayla Bluff-Pearce	-	\$8.90
Cassidy Bobeck	-	\$8.90
Paul Cianflone	-	\$8.90
Brittany Talani	-	\$8.90
Eric Fiorello	-	\$9.00
Cindy Radomski	-	\$9.00
Joseph Bodkin	-	\$9.00
Shannon Kelly	-	\$9.00
Alex Godzich	-	\$9.05
Dave Kruszona	-	\$9.05
Jennifer Laffrado	-	\$9.05
Ryan Weber	-	\$9.05
Jayson Selbert	-	\$9.20
Jessica Arana	-	\$9.25
Meggan Empric	-	\$9.25
Joel Greenauer	-	\$9.25
Brandon Koszuta	-	\$9.25
Sean McCowan	-	\$9.25
Gabrielle Padovani	-	\$9.25
Harley Wiertel	-	\$9.25
Liza Fiorello	-	\$9.30
Timothy Isch	-	\$9.30
Lauren Miller	-	\$9.30
Eugene Pytlewski	-	\$9.30
Slade Miller	-	\$9.50
Melissa Pawlak	-	\$9.50
Ann Marie Heide	-	\$9.55
Daniel Kruszynski	-	\$9.55
Amanda Maconaghy	-	\$9.55
Brian Mayle	-	\$9.55
Elaine Hawrysiak	-	\$9.65
Amy Bowen	-	\$9.80
Amy Godzich	-	\$9.80
Matthew Koszuta	-	\$9.80
Jessica Maleck	-	\$9.80

Samantha Sieg	-	\$9.80
Kristen Stadelmeyer	-	\$9.80
Gary Steltermann	-	\$9.80
Michael Wojcicki	-	\$9.80
Debra Wright	-	\$9.80
Stanley Zolnowski	-	\$9.94
Samuel Alfonso	-	\$10.13
Ariana D'Agostino	-	\$10.13
Ryan Osswald	-	\$10.13
Michael Terranova	-	\$10.13
Joelle Gretch	-	\$10.25
Tyler Kunkel	-	\$10.33
Timothy Petranchuk Jr.	-	\$10.33
James Rogers	-	\$10.33
Erica Orłowski	-	\$10.33
Katherine Tomaschko	-	\$10.33
Melisa Petre	-	\$10.35
Robert Swiatkowski	-	\$10.40
Gayle Anthony	-	\$10.50
Christine Jedd	-	\$10.75
Maribeth Stadelmeyer	-	\$10.75
Jacob Radlich	-	\$10.84
Kathleen Carnall	-	\$11.00
Thomas Goff	-	\$11.00
Lisa Miller	-	\$11.00
Deanna Szymkowiak	-	\$11.25
Joy Donnelly-Smith	-	\$11.40
DeYonca Porter	-	\$11.75
Sandra Suwalski	-	\$12.05
Glenn A. Au	-	\$12.25
Matthew Bean	-	\$12.25
Scott Gretch	-	\$12.25
Ann Sheldon	-	\$12.30
Eric Godzich	-	\$12.45
Melissa Nosal	-	\$12.75

Nancy Fumerelle	-	\$12.80
Jeffrey Kunkel	-	\$13.63
Anthony Pierino	-	\$13.65
Nicholas Russell	-	\$13.75
Laila Desjardins	-	\$13.80
Sean Kunkel	-	\$14.28
Amy McMahon	-	\$15.15
Beatrice Quinn	-	\$16.00
Brad Agen	-	\$17.25
Roger Newhouse	-	\$19.05
Catherine Giles	-	\$21.70

RESULT: ADOPTED [UNANIMOUS]
MOVER: James P. Rogowski, Councilmember
SECONDER: Gerald Kaminski, Councilmember
AYES: James P. Rogowski, Gerald Kaminski, Diane Benczkowski, Timothy J. Meyers
ABSENT: Mary Holtz



24. RESOLUTION 2014-664

Youth & Recreation Termination

Sponsored By: Councilmember Rogowski, Councilmember Kaminski

BE IT RESOLVED that the individual listed below be and hereby are terminated in the Department of Youth & Recreational Services effective as indicated:

Tracey Marlinski

1/18/14

14225

Motion by Councilmember Rogowski; Seconded by Councilmember Meyers to waive the reading of names for the following two (2) resolutions: 2014-664 and 2014-665. Motion Carried.

RESULT: **ADOPTED [UNANIMOUS]**

MOVER: James P. Rogowski, Councilmember

SECONDER: Gerald Kaminski, Councilmember

AYES: James P. Rogowski, Gerald Kaminski, Diane Benczkowski, Timothy J. Meyers

ABSENT: Mary Holtz



25. RESOLUTION 2014-665

Hiring/Termination of Part-Time/Seasonal Employees

Sponsored By: Councilmember Kaminski, Councilmember Rogowski

BE IT RESOLVED, that the following individual be and hereby is hired as a **PART-TIME EMPLOYEE** in the department listed, not to exceed nineteen (19) hours on a weekly basis, in compliance with Civil Service Laws and Regulations as well as the provisions of the Town's collective bargaining agreement between the Town of Cheektowaga and the Town of Cheektowaga Employees Association:

JUSTICE COURT Clerk \$20.00/hour effective 12/5/14
Maureen F. Krause, Cheektowaga, New York

BE IT RESOLVED, that the following seasonal and/or part-time employees be and hereby are terminated as listed:

FACILITIES DEPARTMENT

Brandon P. Barczak effective 10/7/14
Brandon M. Kindzierski effective 10/6/14
Tyler M. Elis effective 10/28/14
Matthew A. Rakowski effective 11/3/14
Michael W. Kowal effective 11/9/14

RESULT:	ADOPTED [UNANIMOUS]
MOVER:	Gerald Kaminski, Councilmember
SECONDER:	James P. Rogowski, Councilmember
AYES:	James P. Rogowski, Gerald Kaminski, Diane Benczkowski, Timothy J. Meyers
ABSENT:	Mary Holtz



26. RESOLUTION 2014-666

Travel Authorization Council Office/Councilmember-Elect Christine Adamczyk

Sponsored By: Councilmember Kaminski, Councilmember Rogowski

WHEREAS, the 2015 Training School for Newly Elected Town Officials is being held January 8 through January 9, 2015 in Binghamton, New York; AND

WHEREAS, Councilmember-Elect Christine Adamczyk has requested authorization to attend said training school; AND

WHEREAS, the total cost to the Town shall not exceed \$750; AND

WHEREAS, these expenses have been budgeted by the Town; NOW, THEREFORE, BE IT

RESOLVED, that Councilmember-Elect Christine Adamczyk be and hereby is authorized to attend the 2015 Training School for Newly Elected Town Officials being held January 8 through January 9, 2015 in Binghamton, New York.

RESULT:	ADOPTED [UNANIMOUS]
MOVER:	Gerald Kaminski, Councilmember
SECONDER:	James P. Rogowski, Councilmember
AYES:	James P. Rogowski, Gerald Kaminski, Diane Benczkowski, Timothy J. Meyers
ABSENT:	Mary Holtz

V. Suspension of Rules

Motion by Councilmember Rogowski; Seconded by Councilmember Meyers to waive the rules to include the following resolution: 2014-667. Motion Carried.



1. RESOLUTION 2014-667

Authorize Supervisor to Execute Revised Schedule A to Order on Consent

Sponsored By: Councilmember Meyers, Councilmember Kaminski

WHEREAS, by resolution dated June 18, 2007, the Town Board authorized the Supervisor to execute an Order on Consent (No. R9-20050317-12) with the New York State Department of Environmental Conservation ("NYSDEC"), and

WHEREAS, the Town Engineer, Town Engineering Consultants and the Town Attorney have worked with the NYSDEC to revise the Schedule A attached to said Order on Consent, and

WHEREAS, the NYSDEC has submitted a revised Schedule A to the Town for its approval, NOW, THEREFORE, BE IT

RESOLVED, that the Supervisor be and hereby is authorized and directed to execute said Revised Schedule A to the aforesaid Order on Consent.

RESULT:	ADOPTED [UNANIMOUS]
MOVER:	Timothy J. Meyers, Councilmember
SECONDER:	Gerald Kaminski, Councilmember
AYES:	James P. Rogowski, Gerald Kaminski, Diane Benczkowski, Timothy J. Meyers
ABSENT:	Mary Holtz

VI. Communications

A. Departmental Communications

1. **Supervisor's Statement of Funds - October 2014**
2. **Minutes: Board of Assessment Review Closing Statement - May 28, 2014**
3. **Minutes: Cheektowaga Traffic Safety Commission - October 21, 2014**
4. **Minutes: Cheektowaga Conservation Advisory Council - November 6, 2014**
5. **Minutes: Cheektowaga Planning Board - November 13, 2014**
6. **Minutes: Cheektowaga Public Library - Board of Trustees - December 3, 2014**

B. General Communications

1. **Summons & Complaint: Scott E. Janus vs. Town of Cheektowaga**
2. **Notice of Claim: Nancy Albanesi vs. Town of Cheektowaga**
3. **Notice of Claim: Natalie Bottomley vs. Town of Cheektowaga**
4. **Notice of Claim: Arthur Burgin vs. Town of Cheektowaga**
5. **Notice of Claim: Donna M. Duszczak vs. Town of Cheektowaga**
6. **Notice of Claim: Laurie & Gary Erhardt vs. Town of Cheektowaga**
7. **Notice of Claim: Kevin Frisch vs. Town of Cheektowaga**
8. **Notice of Claim: Michael Garguiolo vs. Town of Cheektowaga**
9. **Notice of Claim: Victoria Gorenflo vs. Town of Cheektowaga**
10. **Notice of Claim: Steven Graue vs. Town of Cheektowaga**
11. **Notice of Claim: Patricia Hoinski vs. Town of Cheektowaga**
12. **Notice of Claim: Daniel Kaplan vs. Town of Cheektowaga**
13. **Notice of Claim: Paul A. Tokasz vs. Town of Cheektowaga**

VII. Comments

A. Supervisor's Comments

B. Councilmember's Comments

C. Public Comments

VIII. Adjournment

Motion by Councilmember Rogowski; Seconded by Councilmember Meyers to adjourn the meeting at 8:30 PM.

Vickie L. Dankowski, Deputy Town Clerk



Town of Cheektowaga

Work Session

~ Minutes ~

Cheektowaga, NY 14227

<http://www.town.cheektowaga.ny.us>

Alice Magierski
716-686-3400

Tuesday, December 30, 2014

6:00 PM

Council Office

I. Call to Order

6:00 PM Meeting called to order on December 30, 2014 at Council Office, Conference Room, Cheektowaga, NY.

Attendee Name	Organization	Title	Status	Arrived
Mary Holtz	Town of Cheektowaga	Supervisor	Present	
James P. Rogowski	Town of Cheektowaga	Councilmember	Present	
Gerald Kaminski	Town of Cheektowaga	Councilmember	Present	
Diane Benczkowski	Town of Cheektowaga	Councilmember	Present	
Timothy J. Meyers	Town of Cheektowaga	Councilmember	Absent	

2. Additional Attendees

Brian Krause, Director of Finance and Administration
Karen Marchese, Coordinator of Employee Relations
Kevin Schenk, Town Attorney

II. Resolutions



1. RESOLUTION 2014-668

Extend Contract for Liability Claims Management

Sponsored By: Supervisor Holtz, Councilmember Kaminski

WHEREAS, the Town's contract with First Niagara Risk Management, Inc. for liability claims management services will expire on December 31, 2014; and

WHEREAS, there is a need to continue said contract until an updated contract is negotiated; NOW, THEREFORE, BE IT

RESOLVED, that the Town's contract with First Niagara Risk Management, Inc. for liability claims management services be and hereby is extended on its same terms for a term expiring on June 30, 2015; and BE IT FURTHER

RESOLVED, that the Supervisor be and hereby is authorized and directed to execute an amendment to the existing contract with First Niagara Risk Management, Inc.

RESULT:	ADOPTED [UNANIMOUS]
MOVER:	Mary Holtz, Supervisor
SECONDER:	Gerald Kaminski, Councilmember
AYES:	Mary Holtz, James P. Rogowski, Gerald Kaminski, Diane Benczkowski
ABSENT:	Timothy J. Meyers



2. RESOLUTION 2014-669

Purchase of Excess Workers Compensation Insurance

Sponsored By: Supervisor Holtz, Councilmember Kaminski

WHEREAS, the Town's excess workers compensation insurance expired on December 31, 2014, and

WHEREAS, the Town's insurance consultant solicited quotations for said excess workers compensation insurance, and

WHEREAS, Safety National Casualty Corporation, through First Niagara Risk Management, Inc., has submitted a quote for coverage with a \$650,000 retention for Police and a \$600,000 retention for other departments at a cost of \$105,240, NOW, THEREFORE, BE IT

RESOLVED, that this Town Board hereby agrees to purchase excess workers compensation insurance with a \$650,000 retention for Police and a \$600,000 retention for other departments from Safety National Casualty Corporation through First Niagara Risk Management at a cost of \$105,240, and BE IT FURTHER

RESOLVED, that funds for said insurance shall be appropriated from budget line item 101.1722.4519.

RESULT:	ADOPTED [UNANIMOUS]
MOVER:	Mary Holtz, Supervisor
SECONDER:	Gerald Kaminski, Councilmember
AYES:	Mary Holtz, James P. Rogowski, Gerald Kaminski, Diane Benczkowski
ABSENT:	Timothy J. Meyers

III. Adjournment

Motion by Supervisor Holtz; Seconded by Councilmember Rogowski to close the work session at 6:45 PM .

Brian Wielinski, Deputy Town Clerk