

[Download Document](#)**Town of Cheektowaga**

3301 Broadway

Cheektowaga, NY 14227

Work Session<http://www.town.cheektowaga.ny.us>

~ M



Alice Magierski

Tuesday, April, 12 6:00 PM Council Office

I. Call to Order

6:00 PM Meeting called to order on April 12, 2011 at Council Office, Conference Room, Cheektowaga, NY.

Attendee Name	Organization	Title	Status	Arrived
Mary Holtz	Town of Cheektowaga	Supervisor	Present	
Patricia Jaworowicz	Town of Cheektowaga	Councilmember	Late	6:05 PM
Jeff Swiatek	Town of Cheektowaga	Councilmember	Present	
James Rogowski	Town of Cheektowaga	Councilmember	Present	
Richard Zydel	Town of Cheektowaga	Councilmember	Present	
Charles Markel	Town of Cheektowaga	Councilmember	Present	
Stanley Kaznowski	Town of Cheektowaga	Councilmember	Present	

II. Resolutions



SOLUTION 2011-205

Authorize Transfer of 1623 East Delavan Avenue

Sponsored By: Councilmember Markel, Councilmember Kaznowski

WHEREAS, the property located at 1623 East Delavan Avenue in the Town of Cheektowaga was acquired for the purpose of rehabilitating said house for sale to an income-eligible person, and

WHEREAS, New Opportunities Community Housing Development Corp., a not-for-profit housing agency, has agreed to purchase property located at 1623 East Delavan Avenue from the Town of Cheektowaga for the purpose of rehabilitating and selling said property to an income-eligible homebuyer, NOW, THEREFORE, BE IT

RESOLVED, that the Supervisor be and hereby is authorized and directed to execute a deed and other documents necessary to effectuate the sale of 1623 East Delavan Avenue to New Opportunities Community Housing Development Corp., and BE IT FURTHER

RESOLVED, that the sale of 1623 East Delavan Avenue is subject to permissive referendum under the Town Law of the State of New York, and BE IT FURTHER

RESOLVED, that the Town Clerk be and hereby is directed to file the attached Notice of adoption of Resolution Subject to Permissive Referendum on the CHEEKTOWAGA BEE, the Town's official newspaper.

**NOTICE OF ADOPTION OF RESOLUTION
SUBJECT TO PERMISSIVE REFERENDUM**

NOTICE IS HEREBY GIVEN, that the Town Board of the Town of Cheektowaga, on April 12, 2011 adopted a resolution authorizing the Town of Cheektowaga to sell property located at 1623 East Delavan Avenue, Cheektowaga, New York to New Opportunities Community Housing Development Corp. for \$1.00.

A copy of such resolution is on file in the Town Clerk's Office where the same may be viewed during regular business hours.

TAKE FURTHER NOTICE, that such resolution is subject to permissive referendum under Article 7 of the Town Law of the State of New York.

BY ORDER OF THE TOWN BOARD OF THE TOWN OF CHEEKTOWAGA, ERIE COUNTY, NEW YORK

DATED: April 12, 2011

ALICE MAGIERSKI
Town Clerk

RESULT:	ADOPTED [UNANIMOUS]
MOVER:	Charles Markel, Councilmember
SECONDER:	Stanley Kaznowski, Councilmember
AYES:	Holtz, Jaworowicz, Swiatek, Rogowski, Zydel, Markel, Kaznowski



SOLUTION 2011-206

Approve Assignment of Loss Control Services Agreement

Sponsored By: Councilmember Swiatek, Councilmember Zydel

WHEREAS, by resolution dated November 1, 2010 (Reslution2010-612), this Town Board awarded a contract for Loss Control Services to Gerster Safety, effective November 1, 2010 and terminating on October 31, 2013 (unless terminated earlier by the Town as per the contract), and

WHEREAS, Gerster Safety has notified the Town of Cheektowaga that it desires to assign this contract to Mages Risk Management, LLC, and

WHEREAS, James W. Mages, Managing Member of Mages Risk Management, LLC has worked for the Town of Cheektowaga on loss control services for many years and has the expertise and experience in this field, NOW, THEREFORE, BE IT

RESOLVED, that this Town Board hereby consents to the assignment of the aforementioned Loss Control Services contract from Gerster Safety to Mages Risk Management, LLC.

RESULT:	ADOPTED [UNANIMOUS]
MOVER:	Jeff Swiatek, Councilmember
SECONDER:	Richard Zydel, Councilmember
AYES:	Holtz, Jaworowicz, Swiatek, Rogowski, Zydel, Markel, Kaznowski



SOLUTION 2011-207

Award Contract for Grass Cutting of Town Properties

Sponsored By: Supervisor Holtz, Councilmember Markel

WHEREAS, the Town of Cheektowaga owns 15± residential properties on which the grass needs to be regularly cut, and

WHEREAS, a Request for Proposals ("RFP") was issued to have private contractors perform these services, and

WHEREAS, proposals were received from three (3) firms, and

WHEREAS, the proposal having the lowest cost to the Town was submitted by Grabber & Sons Landscaping & Nursery, NOW, THEREFORE, BE IT

RESOLVED, that the contract for lawn cutting for the 15 Town properties shown on the list for the RFP be and hereby is awarded to Grabber & Sons Landscaping & Nursery, a/k/a Grabber & Sons, Inc., 3242 Harlem Road, Cheektowaga, New York 14225 at a cost per lawn cutting of \$35.00, and BE IT FURTHER

RESOLVED, that the Supervisor be and hereby is authorized and directed to execute a contract and any and all other documents to effectuate terms of a contract for these services, and BE IT FURTHER

RESOLVED, that the fees for said services shall be appropriated from the following Town budget line items:

- Account #800-3620-4561
- Account #700-1007-0606

RESULT:	ADOPTED [UNANIMOUS]
MOVER:	Mary Holtz, Supervisor
SECONDER:	Charles Markel, Councilmember
AYES:	Holtz, Jaworowicz, Swiatek, Rogowski, Zydel, Markel, Kaznowski



Town of Cheektowaga

Work Session

~ Minutes ~

3301 Broadway
Cheektowaga, NY 14227
<http://www.town.cheektowaga.ny.us>

Alice Magierski
716-686-3400

Tuesday, March, 1, 2011

6:00 PM

Council Office

I. Call to Order

6:00 PM Meeting called to order on March 1, 2011 at Council Office, Conference Room, Cheektowaga, NY.

Attendee Name	Organization	Title	Status	Arrived
Mary Holtz	Town of Cheektowaga	Supervisor	Present	
Patricia Jaworowicz	Town of Cheektowaga	Councilmember	Present	
Jeff Swiatek	Town of Cheektowaga	Councilmember	Present	
James Rogowski	Town of Cheektowaga	Councilmember	Present	
Richard Zydel	Town of Cheektowaga	Councilmember	Present	
Charles Markel	Town of Cheektowaga	Councilmember	Present	
Stanley Kaznowski	Town of Cheektowaga	Councilmember	Present	

2. Additional Attendees

Brian Krause, Director of Finance and Administration
Anthony Romano, Coordinator of Employee Relations
Kevin Schenk, Town Attorney
David Zack, Chief of Police

II. Resolutions

1. Motion To: Enter Executive Session

COMMENTS - Current Meeting:

To Discuss Litigation Matters.

RESULT: ADOPTED [UNANIMOUS]
MOVER: Mary Holtz, Supervisor
SECONDER: Richard Zydel, Councilmember
AYES: Holtz, Jaworowicz, Swiatek, Rogowski, Zydel, Markel, Kaznowski

2. Motion To: Exit Executive Session

RESULT: ADOPTED [UNANIMOUS]
MOVER: Charles Markel, Councilmember
SECONDER: Mary Holtz, Supervisor
AYES: Holtz, Jaworowicz, Swiatek, Rogowski, Zydel, Markel, Kaznowski



3. RESOLUTION 2011-116

Settlement of Litigation - Randolph Vs Town

Sponsored By: Councilmember Swiatek, Councilmember Zydel

WHEREAS, on or about February 27, 2001, an action (Sarah Randolph vs Town of Cheektowaga, et al, Index No. I-2001-1782) was commenced against the Town; and

WHEREAS, the law firm of Damon & Morey LLP (Marylou K. Roshia, Esq., of counsel) was retained to represent the Town; vigorously defended the interests of the Town with regard to this claim; and has recommended a settlement with the claimant's attorneys; and

WHEREAS, this settlement is in the best interests of the Town of Cheektowaga;

NOW THEREFORE, BE IT

RESOLVED, that the Town Board approves of the above settlement with the Stipulation of Discontinuance and Settlement Agreement and Release being signed by the plaintiff; and the Supervisor, Town Attorney and/or Damon & Morey, LLP be and hereby are authorized to execute and procure all papers necessary to effectuate said settlement and compromise of the above mentioned claim in accordance with the terms of the Settlement Agreement and Release and Stipulation of Discontinuance.

RESULT:	ADOPTED [UNANIMOUS]
MOVER:	Jeff Swiatek, Councilmember
SECONDER:	Richard Zydel, Councilmember
AYES:	Holtz, Jaworowicz, Swiatek, Rogowski, Zydel, Markel, Kaznowski

4. Motion To: Enter Executive Session

COMMENTS - Current Meeting:

To discuss Personnel Matters.

RESULT:	ADOPTED [UNANIMOUS]
MOVER:	Jeff Swiatek, Councilmember
SECONDER:	Charles Markel, Councilmember
AYES:	Holtz, Jaworowicz, Swiatek, Rogowski, Zydel, Markel, Kaznowski

5. Motion To: Exit Executive Session

RESULT:	ADOPTED [UNANIMOUS]
MOVER:	Stanley Kaznowski, Councilmember
SECONDER:	James Rogowski, Councilmember
AYES:	Holtz, Jaworowicz, Swiatek, Rogowski, Zydel, Markel, Kaznowski

III. Adjournment

Work Session Ends at 7 pm.



Town of Cheektowaga

Regular Meeting

~ Minutes ~

3301 Broadway
Cheektowaga, NY 14227
<http://www.town.cheektowaga.ny.us>

Alice Magierski
716-686-3400

Monday, January 3, 2011

6:45 PM

Council Chambers

I. Call to Order

6:45 PM Meeting called to order on January 3, 2011 at Council Chambers, 3301 Broadway St, Cheektowaga, NY.

Attendee Name	Organization	Title	Status	Arrived
Mary Holtz	Town of Cheektowaga	Supervisor	Present	
Patricia Jaworowicz	Town of Cheektowaga	Councilmember	Present	
Jeff Swiatek	Town of Cheektowaga	Councilmember	Present	
James Rogowski	Town of Cheektowaga	Councilmember	Present	
Richard Zydel	Town of Cheektowaga	Councilmember	Present	
Charles Markel	Town of Cheektowaga	Councilmember	Present	
Stanley Kaznowski	Town of Cheektowaga	Councilmember	Present	

2. Additional Attendees

Thomas Adamczak, Supervising Building and Plumbing Inspector
John Marriott, Planning Board Chairman
William Pugh, Town Engineer
Anthony Romano, Coordinator of Employee Relations
Kevin Schenk, Town Attorney
Kerry Switalski, Senior Services Director
Christine Ziemba, Chief of Police

II. Public Comment Period

III. Resolutions



1. RESOLUTION 2011-1

Transfer of Funds

Sponsored By: Supervisor Holtz, Councilmember Swiatek

BE IT RESOLVED, that the following transfer is hereby approved and made a part hereof;

Capital Fund

From: 500.1440.9910.2028	Highway Storm Drainage	\$15,742.00
To: 500.9950.9901.5028	Transfers Out	\$15,742.00

General Fund

From: 100.1910.3088	Miscellaneous State Aid	\$ 3,245.96
100.1110.1901	Payroll Regular	1,568.00
100.1315.1901	Payroll Regular	2,773.00
100.1355.1901	Payroll Regular	1,086.00
100.1420.4501	Contracted Legal	1,114.00
100.1430.4088	Travel, Training, & Conference	1,297.00
100.1440.1901	Payroll Regular	525.00
100.1440.1901	Payroll Regular	1,255.00
100.1625.1951	Seasonal Regular	2,417.00
100.1640.1901	Payroll Regular	3,786.00
100.3020.1901	Payroll Regular	1,838.00
100.7140.1914	Shift Differential	835.00
100.7620.1931	Vacation Sell Back	308.00
To: 100.1220.4010.0002	Disaster Preparedness	\$ 3,245.96
100.1110.1931	Vacation Sell Back	1,568.00
100.1315.1932	Sick Sell Back	2,773.00
100.1355.1932	Sick Sell Back	1,086.00
100.1420.1931	Vacation Sell Back	1,114.00
100.1430.1931	Vacation Sell Back	1,297.00
100.1440.1931	Vacation Sell Back	525.00
100.1440.1932	Sick Sell Back	1,255.00
100.1625.1931	Vacation Sell Back	1,192.00
100.1625.1932	Sick Sell Back	1,225.00
100.1640.1931	Vacation Sell Back	2,586.00
100.1640.1990	Other Pay	1,200.00
100.3020.1931	Vacation Sell Back	1,208.00
100.3020.1932	Sick Sell Back	630.00
100.7140.1932	Sick Sell Back	835.00
100.7620.1932	Sick Sell Back	308.00

Highway Fund

From: 300.1910.5031	Transfers In	\$15,742.00
300.5141.1901	Payroll Regular	2,464.00

To:	300.5141.1902	Overtime	\$15,742.00
	300.5141.1931	Vacation Sell Back	2,464.00

Special Districts

From:	150.8160.4211	Electric	\$ 123.00
	150.8160.1932	Sick Sell Back	1,394.00
	255.8125.1901	Payroll Regular	4,004.00
	255.8135.1902	Overtime Payroll	4,213.00

To:	150.8160.4071	Uniform Replacement	\$ 123.00
	150.8160.1931	Vacation Sell Back	1,394.00
	255.8125.1931	Vacation Sell Back	3,810.00
	255.8125.1932	Sick Sell Back	194.00
	255.8135.1911	Longevity	620.00
	255.8135.1931	Vacation Sell Back	1,394.00
	255.8135.1932	Sick Sell Back	2,199.00

RESULT:	ADOPTED [UNANIMOUS]
MOVER:	Mary Holtz, Supervisor
SECONDER:	Jeff Swiatek, Councilmember
AYES:	Holtz, Jaworowicz, Swiatek, Rogowski, Zydel, Markel, Kaznowski



2. RESOLUTION 2011-2

Warrant

Sponsored By: Supervisor Holtz, Councilmember Swiatek

BE IT RESOLVED, that the following Vouchers & Warrants submitted to the Town of Cheektowaga prior to December 31, 2010 are hereby approved and made a part hereof;

General Fund	\$240,817.64
Risk Retention Fund	30,162.07
HUD Housing Rehabilitation Fund	12,008.00
Special Districts Fund	228,749.84
Highway Fund	77,386.49
Capital Fund	177,906.09
Trust & Agency Fund	1,240.22
HUD CDBG Fund	3,234.73
Part Town Fund	3,633.59
NYS Affordable Housing	<u>10,207.00</u>
	\$785,345.67

RESULT: **ADOPTED [UNANIMOUS]**

MOVER: Mary Holtz, Supervisor

SECONDER: Jeff Swiatek, Councilmember

AYES: Holtz, Jaworowicz, Swiatek, Rogowski, Zydel, Markel, Kaznowski



3. RESOLUTION 2011-3

Award of Bid-Youth & Recreation Clothing

Sponsored By: Councilmember Zydel, Councilmember Rogowski

WHEREAS, sealed bids were duly received by the Town Board at a bid opening on December 22, 2010 for the furnishing of clothing as a result of advertising thereof, and such bids were referred to the Department of Youth and Recreational Services for analysis, tabulation and report, and

WHEREAS, such analysis, tabulation and report have been complete, BE IT

RESOLVED that bids be awarded to the lowest responsible bidder meeting specifications, and to be in the best interest of the Town of Cheektowaga for the 2011, 2012, 2013 calendar years:

Laux Sporting Goods Inc
25 Pineview Drive
Amherst, NY 14228

Jim Ludtka Sporting Goods
3950 Broadway
Depew, NY 14043

Great Idea Promotions
10057 Griener Road
Clarence, NY 14031

C* Shore Design
37 South Shore Drive
Alden, NY 14004

BE IT FURTHER RESOLVED that the costs resulting from the awarding of this bid are funded through 7140, 7180 and 7310 accounts for cost centering purposes.

RESULT:	ADOPTED [UNANIMOUS]
MOVER:	Richard Zydel, Councilmember
SECONDER:	James Rogowski, Councilmember
AYES:	Holtz, Jaworowicz, Swiatek, Rogowski, Zydel, Markel, Kaznowski



4. RESOLUTION 2011-4

Award of Bid for Asbestos Survey for 1112 Walden Avenue

Sponsored By: Councilmember Markel, Councilmember Kaznowski

WHEREAS, pursuant to the Unsafe Buildings Law of the Town of Cheektowaga, this Town Board can require that unsafe buildings be either repaired or demolished, and

WHEREAS, the building located at 1112 Walden Avenue has experienced extensive deterioration and damage, and Nussbaumer & Clarke, Inc. determined that said building is unsafe and recommended that such building be demolished and removed, and

WHEREAS, by resolution dated September 7, 2010 (#2010-505), this Town Board ordered that the building located at 1112 Walden Avenue be either repaired or demolished, and directed that the owners or others responsible for the building commence said repair or demolition work within 30 days, and

WHEREAS, more than 30 days have expired and no work has been commenced with respect to 1112 Walden Avenue, and

WHEREAS, pursuant to the Unsafe Buildings Law, this Town Board can provide for the demolition of an unsafe building and assess the cost of same against the property, and

WHEREAS, prior to the demolition of 1112 Walden Avenue, the Town needs to retain a firm to perform an asbestos survey and asbestos abatement plan for same, and

WHEREAS, this Town Board issued a Notice to Bidders to various asbestos abatement firms and, based on proposals submitted, the Town Attorney has recommended that this Town Board retain 56 Services, Inc. at the total flat fee of \$1,490.00 to perform said asbestos survey, specifications and project monitoring work with respect to 1112 Walden Avenue, NOW, THEREFORE, BE IT

RESOLVED, that this Town Board hereby retains 56 Services, Inc., P.O. Box 561, Buffalo, New York 14213 to perform the necessary asbestos survey and abatement work (if necessary) for 1112 Walden Avenue at the cost listed above, and BE IT FURTHER

RESOLVED, that the Supervisor be and hereby is directed to execute an agreement with 56 Services, Inc. for said services, and BE IT FURTHER

RESOLVED, that moneys for said services shall be appropriated from budget line item number 0800-800-0440.

RESULT:	ADOPTED [UNANIMOUS]
MOVER:	Charles Markel, Councilmember
SECONDER:	Stanley Kaznowski, Councilmember
AYES:	Holtz, Jaworowicz, Swiatek, Rogowski, Zydel, Markel, Kaznowski



5. RESOLUTION 2011-5

Award of Bid for Asbestos Survey for 2371 Genesee Street

Sponsored By: Councilmember Markel, Councilmember Kaznowski

WHEREAS, pursuant to the Unsafe Buildings Law of the Town of Cheektowaga, this Town Board can require that unsafe buildings be either repaired or demolished, and

WHEREAS, the building located at 2371 Genesee Street has experienced extensive deterioration and damage, and Nussbaumer & Clarke, Inc. determined that said building is unsafe and recommended that such building be demolished and removed, and

WHEREAS, by resolution dated September 7, 2010 (#2010-506), this Town Board ordered that the building located at 2371 Genesee Street be either repaired or demolished, and directed that the owners or others responsible for the building commence said repair or demolition work within 30 days, and

WHEREAS, more than 30 days have expired and no work has been commenced with respect to 2371 Genesee Street, and

WHEREAS, pursuant to the Unsafe Buildings Law, this Town Board can provide for the demolition of an unsafe building and assess the cost of same against the property, and

WHEREAS, prior to the demolition of 2371 Genesee Street, the Town needs to retain a firm to perform an asbestos survey and asbestos abatement plan for same, and

WHEREAS, this Town Board issued a Notice to Bidders to various asbestos abatement firms and, based on proposals submitted, the Town Attorney has recommended that this Town Board retain 56 Services, Inc. at the total flat fee of \$925.00 to perform said asbestos survey, specifications and project monitoring work with respect to 2371 Genesee Street, NOW, THEREFORE, BE IT

RESOLVED, that this Town Board hereby retains 56 Services, Inc., P.O. Box 561, Buffalo, New York 14213 to perform the necessary asbestos survey and abatement work (if necessary) for 2371 Genesee Street at the cost listed above, and BE IT FURTHER

RESOLVED, that the Supervisor be and hereby is directed to execute an agreement with 56 Services, Inc. for said services, and BE IT FURTHER

RESOLVED, that moneys for said services shall be appropriated from budget line item number 0800-800-0440.

RESULT:	ADOPTED [UNANIMOUS]
MOVER:	Charles Markel, Councilmember
SECONDER:	Stanley Kaznowski, Councilmember
AYES:	Holtz, Jaworowicz, Swiatek, Rogowski, Zydel, Markel, Kaznowski



6. RESOLUTION 2011-6

Award of Bid for Grass Cutting, Landscape Work, Etc. on Vacant Properties

Sponsored By: Councilmember Markel, Councilmember Kaznowski

Garden WHEREAS, a Notice to Bidders was published for the receipt of bids for Furnishing Equipment and Operators for Grass Cutting and Landscape Work on Vacant Land and Unmaintained Properties for the Office of Building Inspections, Housing & Neighborhood Preservation Division for 2011, which bids were duly received and opened on December 22, 2010 by the Town Clerk; and

WHEREAS, said bids were referred to the Supervising Code Enforcement Officer and Town Attorney for analysis, tabulation and report, and

WHEREAS, the Supervising Code Enforcement Officer and Town Attorney recommend that the contract for the Furnishing Equipment and Operators for Grass Cutting and Landscape Work on Vacant Land and Unmaintained Properties be awarded to Gardenville Landscaping and Nursery, LLC for its submission of the lowest bid; NOW, THEREFORE, BE IT

RESOLVED, that the bid for the Furnishing Equipment and Operators for Grass Cutting and Landscape Work on Vacant Land and Unmaintained Properties for 2011 be and hereby is awarded to Gardenville Landscaping and Nursery, LLC, 3069 Clinton Street, West Seneca, New York 14224 for the bid prices listed in its proposal, being the lowest responsible bid meeting the requirements of the specifications for said bid item; and BE IT FURTHER

RESOLVED, that the Supervisor, on behalf of this Town Board, be and hereby is directed and authorized to execute the contract with Gardenville Landscaping and Nursery, LLC for the aforesaid service.

RESULT:	ADOPTED [UNANIMOUS]
MOVER:	Charles Markel, Councilmember
SECONDER:	Stanley Kaznowski, Councilmember
AYES:	Holtz, Jaworowicz, Swiatek, Rogowski, Zydel, Markel, Kaznowski



7. RESOLUTION 2011-7

Award of Bid for Snow Removal on Vacant Properties

Sponsored By: Councilmember Markel, Councilmember Kaznowski

WHEREAS, a Notice to Bidders was published for the receipt of bids for Furnishing Equipment and Operators for the Removal of Snow and Ice from Public Sidewalks Adjoining Vacant Land and Unmaintained Properties for the Office of Building Inspections, Housing & Neighborhood Preservation Division for 2011, which bids were duly received and opened on December 22, 2010 by the Town Clerk; and

WHEREAS, said bids were referred to the Supervising Code Enforcement Officer and Town Attorney for analysis, tabulation and report, and

WHEREAS, the Supervising Code Enforcement Officer and Town Attorney recommend that the contract for Furnishing Equipment and Operators for the Removal of Snow and Ice from Public Sidewalks Adjoining Vacant Land and Unmaintained Properties be awarded to Gardenville Landscaping and Nursery, LLC for its submission of the lowest bid; NOW, THEREFORE, BE IT

RESOLVED, that the bid for the Furnishing Equipment and Operators for the Removal of Snow and Ice from Public Sidewalks Adjoining Vacant Land and Unmaintained Properties for 2011 be and hereby is awarded to Gardenville Landscaping and Nursery, LLC, 3069 Clinton Street, West Seneca, New York 14224 for the bid prices listed in its proposal, being the lowest responsible bid meeting the requirements of the specifications for said bid item; and BE IT FURTHER

RESOLVED, that the Supervisor, on behalf of this Town Board, be and hereby is directed and authorized to execute the contract with Gardenville Landscaping and Nursery, LLC for the aforesaid service.

RESULT:	ADOPTED [UNANIMOUS]
MOVER:	Charles Markel, Councilmember
SECONDER:	Stanley Kaznowski, Councilmember
AYES:	Holtz, Jaworowicz, Swiatek, Rogowski, Zydel, Markel, Kaznowski



8. RESOLUTION 2011-8

Award of Bid for 6200 Square Feet Rubber Floor Tile

Sponsored By: Councilmember Rogowski, Councilmember Zydel

WHEREAS, bid proposals were received for the purchase of 6200 Square Feet Rubber Floor Tile, 24" x 24" x 3/8" Interlocking Rubber Tile, Color Code #329 for the Town Park Recreation Center on December 1, 2010, NOW THEREFORE BE IT

WHEREAS, said proposals have been reviewed for compliance under the terms of the specifications, NOW THEREFORE BE IT,

RESOLVED, that the Cheektowaga Town Board hereby award said Bid for the purchase of 6200 Square Feet Rubber Floor Tile, 24" x 24" x 3/8" Interlocking Rubber Tile, Color Code #329 for the Town Park Recreation Center to:

Heritage Contract Flooring
29 Depot Street
Buffalo, NY 14206

RESULT:	ADOPTED [UNANIMOUS]
MOVER:	James Rogowski, Councilmember
SECONDER:	Richard Zydel, Councilmember
AYES:	Holtz, Jaworowicz, Swiatek, Rogowski, Zydel, Markel, Kaznowski



9. RESOLUTION 2011-9

Award of Bid - Boarding Up Buildings & Minor Demolitions, Etc.

Sponsored By: Councilmember Markel, Councilmember Kaznowski

WHEREAS, a Notice to Bidders was published for the receipt of bids for Furnishing Equipment and Operators for the Boarding Up/Securing of and Minor Demolition of Buildings/Structures on Vacant Land and Unmaintained Properties for the Office of Building Inspections, Housing & Neighborhood Preservation Division for 2011, which bids were duly received and opened on December 22, 2010 by the Town Clerk; and

WHEREAS, said bids were referred to the Supervising Code Enforcement Officer and Town Attorney for analysis, tabulation and report, and

WHEREAS, the Supervising Code Enforcement Officer and Town Attorney recommend that the contract for Furnishing Equipment and Operators for the Boarding Up/Securing of and Minor Demolition of Buildings/Structures on Vacant Land and Unmaintained Properties be awarded to Superior General Contracting, Inc. for its submission of the lowest bid; NOW, THEREFORE, BE IT

RESOLVED, that the bid for Furnishing Equipment and Operators for the Boarding Up/Securing of and Minor Demolition of Buildings/Structures on Vacant Land and Unmaintained Properties for 2011 be and hereby is awarded to Superior General Contracting, Inc., 1035 Rein Road, Cheektowaga, NY 14225 for the bid prices listed in its proposal, being the lowest responsible bid meeting the requirements of the specifications for said bid item; and BE IT FURTHER

RESOLVED, that the Supervisor, on behalf of this Town Board, be and hereby is directed and authorized to execute the contract with Superior Contracting for the aforesaid service.

RESULT:	ADOPTED [UNANIMOUS]
MOVER:	Charles Markel, Councilmember
SECONDER:	Stanley Kaznowski, Councilmember
AYES:	Holtz, Jaworowicz, Swiatek, Rogowski, Zydel, Markel, Kaznowski



10. RESOLUTION 2011-10

Call for Public Hearing for the Community Development Block Grant Program

Sponsored By: Councilmember Markel, Councilmember Kaznowski

WHEREAS, the Town is eligible to receive approximately \$1,150,000 in Community Development Block Grant funds and approximately \$382,500 in Home Investment Partnership program funds for the 2011 Program Year, and

WHEREAS, the Town is required to hold public hearings to obtain the views of Town residents, public agencies and other interested parties on housing and community development needs in the Town, and

WHEREAS, activities proposed for funding with Program Year 2011 Community Development Block Grant and HOME Program funds have been made available for public review in the public libraries within the Town, the Cheektowaga Town Clerk's Office and the Community Development Office, NOW, THEREFORE, BE IT

RESOLVED, that a public hearing be held on January 18, 2011 at 6:45 P.M. at Cheektowaga Town Hall, 3301 Broadway, Cheektowaga, New York 14227 for the above stated purpose, and BE IT

FURTHER RESOLVED, that the public notice of such public hearing be published in the Cheektowaga Bee on Thursday, January 6, 2011.

Notice of Public Hearing
Town of Cheektowaga FY 2011 Annual Plan
Community Development Block Grant/HOME Programs

A public hearing will be held on Tuesday, January 18, 2011 at 6:45 P.M. at Cheektowaga Town Hall, 3301 Broadway, Cheektowaga, NY 14227 on the Town's Fiscal Year 2011 Annual Plan for the Community Development Block Grant (CDBG) and HOME Investment Partnership Act (HOME) Programs to obtain the views of citizens and interested parties on housing and community development needs in the Town and on the draft Action Plan which has been made available for public review in Cheektowaga Branch Libraries. The Annual Plan outlines housing and community development projects proposed to be funded with FY 2011 CDBG and HOME Program funds. The Town is eligible to receive approximately \$1,150,000 in CDBG funds and approximately \$382,500 in HOME Investment Partnership Program funds from HUD in 2011. The Town estimates approximately \$200,000 in program income from its revolving housing rehabilitation loan program and \$300,000 in economic development revolving business loan program income will be received. Those wishing to offer comments at the hearing are asked to also submit a written text, which may also be submitted to the Cheektowaga Community Development Office, 275 Alexander Avenue, Cheektowaga, New York, 14211. Interpreters will be made available at the meetings upon prior request to sign for the hearing impaired. If you need such special arrangements, contact the Cheektowaga Community Development Office at 897-7200, Ext. 6, at least seven (7) business days prior to the hearing. The hearing location is

accessible to the physically disabled.

ATTACHMENTS:

PH-NOTICE-2011B (DOC)

RESULT: ADOPTED [UNANIMOUS]**MOVER:** Charles Markel, Councilmember**SECONDER:** Stanley Kaznowski, Councilmember**AYES:** Holtz, Jaworowicz, Swiatek, Rogowski, Zydel, Markel, Kaznowski



11. RESOLUTION 2011-11

Call for Public Hearing - 2185 Walden Avenue

Sponsored By: Markel, Kaznowski, Rogowski

WHEREAS, the Derrick Corporation has made application and requested the rezoning of 4.81 acres of vacant land at 2185 Walden Avenue from MS- Motor Service district to M1- Light Manufacturing district for the construction of a 123,555 square foot manufacturing addition to Derrick Corporation at 590 Duke Road, NOW, THEREFORE BE IT

RESOLVED, that a Public Hearing be held regarding said request under the provisions of the Zoning Law on Tuesday, January 18th, 2011 at 6:45 P.M., at the Cheektowaga Town Hall, 3301 Broadway at the corner of Union Road.

Notice of Public Hearing

NOTICE IS HEREBY GIVEN that a Public Hearing will be held by the Town Board of the Town of Cheektowaga, Erie County, New York at the Town Hall in the said Town of Cheektowaga, 3301 Broadway corner of Union Road on the 18th day of January, 2011 at 6:45 P.M., of said day for the purpose of considering the application of:

Derrick Corporation

for the rezoning of 4.81 acres of vacant land at 2185 Walden Avenue from MS- Motor Service district to M1- Light Manufacturing district for the construction of a 123,555 square foot manufacturing addition to Derrick Corporation at 590 Duke Road.

All parties in interest and citizens will be given an opportunity to be heard in regard to such proposed application.

BY ORDER OF THE TOWN BOARD, Town of Cheektowaga, NY
Alice Magierski, TOWN CLERK

LEGAL DESCRIPTION

PARCEL A

ALL THAT TRACT OR PARCEL OF LAND, situate in the Town of Cheektowaga, County of Erie and State of New York, being part of Lot No. 16, Township 11, Range 7 of the Holland Land Company's Survey, bounded as follows:

BEGINNING in the northwesterly line of Duke Road at the most southerly corner of lands described in a memorandum of lease to Sun Oil Company recorded in Erie County Clerk's Office in Liber 5816 of Deeds, at Page 13+ADs- running thence south 30?-27' west along said northwesterly line of Duke Road 31.18 feet to an angle in said line+ADs- thence continuing southwesterly along the northwesterly line of Duke Road 787.34 feet to the east line of lands

conveyed to Lawrence Walsh by deed recorded in Erie County Clerk's Office in Liber 255 of Deeds, at Page 112+ADs- thence northerly along said east line 707.44 feet to the north line of lands conveyed to Elijah Efner by deed recorded in Erie County Clerk's Office in Liber 232 of Deeds at Page 634+ADs- thence easterly along said north line 552.42 feet to the west line of lands leased to Sun Oil Company as described in memorandum of lease aforesaid+ADs- thence southerly along said west line of 94 feet to an angle in said line+ADs- and thence southeasterly still along lands so described 131 feet to the point of beginning.

EXCEPT THEREFROM ALL THAT TRACT OR PARCEL OF LAND situate in the Town of Cheektowaga, County of Erie and State of New York being part of Lot No. 16, Township 11, Range 7 of the Holland Land Company's survey, described as follows: Beginning in the north line of Duke Road (66 feet wide), at its intersection with the east line of lands of Lawrence Walsh described in deed recorded in Liber 255 of Deed page 112+ADs- thence northeasterly along said east line of the lands of Walsh, for a distance of 707.44 feet to the north line of lands of Elijah Efner described in deed recorded in Liber 232 of Deeds page 634+ADs- thence easterly along said north line of the lands of Elijah Efner, for a distance of 125.01 feet to a point on said north line, which is located 577.41 feet westerly of the east line of Lot No. 16: thence southwesterly at an interior angle with the last described line of 89°-20'-58+ACI-, for a distance of 610.79 feet to a point on said north line of Duke Road, distant 159.46 feet easterly of the intersection of said north line of Duke Road with said east line of the lands of Walsh as described in deed recorded in the Erie County Clerk's Office in Liber 255 of Deeds page 112: thence southwesterly along said north line of Duke Road, for a distance of 159.46 feet to the point or place of beginning.

PARCEL B

ALL THAT CERTAIN PLOT, PIECE OR PARCEL OF LAND, situate, lying and being in the Town of Cheektowaga, County of Erie, State of New York being part of Lot number 16, Township 11, Range 7 of the Holland Land Company's Survey more particularly bounded and described as follows:

BEGINNING at the most easterly point of lands conveyed to Carlton W. Hasselback by deed recorded in the Erie County Clerk's Office in Liber 5956 of Deeds page 398, said point of beginning also being 82.54 feet westerly from the east line of Liber 6694 of Deeds page 273, as measured along the southerly highway boundary line of Walden Avenue.

RUNNING THENCE westerly along the southerly line of such land in said Liber 5956 of Deeds page 398 a distance of 289.80 feet to a point+ADs-

RUNNING THENCE northerly at right angles, a distance of 66.97 feet, (said line being 80.05 feet easterly from the southeasterly corner of the car wash structure now situated on the premises immediately adjoining on the west) to a point on the southerly highway boundary line of Walden Avenue+ADs-

RUNNING THENCE southeasterly at an interior angle of 76 degrees 59'-15+ACI- and along the said southerly line of Walden Avenue, 297.43 feet to the POINT or PLACE of BEGINNING.

Being the same premises described in the deed dated 6/7/68 recorded 6/7/68 in Liber 7475 Page 417.

ATTACHMENTS:

2185 Walden Avenue - Legal Description (DOC)

RESULT:	ADOPTED [UNANIMOUS]
MOVER:	Charles Markel, Councilmember
SECONDER:	Stanley Kaznowski, Councilmember
AYES:	Holtz, Jaworowicz, Swiatek, Rogowski, Zydel, Markel, Kaznowski



12. RESOLUTION 2011-12

Designate Official Newspaper

Sponsored By: Holtz, Jaworowicz, Swiatek, Rogowski, Zydel, Markel, Kaznowski

WHEREAS, Section 64(11) of the Town Law empowers a Town Board to designate a newspaper as the official paper of the Town provided such newspaper is regularly published in the Town and has been entered as second class mail matter, and

WHEREAS, the CHEEKTOWAGA BEE has served as the official newspaper of the Town of Cheektowaga for the past several months, and is qualified to serve as the Town's official newspaper, NOW, THEREFORE, BE IT

RESOLVED, that THE CHEEKTOWAGA BEE be and hereby is designated as the official newspaper of the Town of Cheektowaga.

RESULT:	ADOPTED [UNANIMOUS]
MOVER:	Mary Holtz, Supervisor
SECONDER:	Patricia Jaworowicz, Councilmember
AYES:	Holtz, Jaworowicz, Swiatek, Rogowski, Zydel, Markel, Kaznowski



13. RESOLUTION 2011-13

Designation of Depositories for 2011

Sponsored By: Supervisor Holtz, Councilmember Swiatek

BE IT RESOLVED, that the following banking institutions be named official Town Depositories for the Year 2011:

HSBC Bank (Cheektowaga Office)
Manufacturers and Traders Trust Company (Airport Plaza)
Key Bank (Appletree Business Park and Union Road)
Bank of America (Dick Road Office))
JP Morgan Chase Bank, N.A. (Buffalo Office)
Citizens Bank (Cheektowaga Office)
Evans National Bank

RESULT:	ADOPTED [UNANIMOUS]
MOVER:	Mary Holtz, Supervisor
SECONDER:	Jeff Swiatek, Councilmember
AYES:	Holtz, Jaworowicz, Swiatek, Rogowski, Zydel, Markel, Kaznowski



14. RESOLUTION 2011-14

Request Banks to Accept Facsimile Signatures

Sponsored By: Supervisor Holtz, Councilmember Swiatek

BE IT RESOLVED, that HSBC Bank (Cheektowaga Office), Bank of America (Dick Road Office), Key Bank (Cheektowaga Office), JP Morgan Chase Bank, N.A. (Buffalo Office), Citizens Bank (Cheektowaga Office), Evans National Bank and Manufacturers and Traders Trust Company (Airport Plaza Office), as designated depositories of the Town of Cheektowaga, be and they are hereby requested, authorized and directed to honor checks, notes and other instruments for the payment of moneys against Town funds on deposit therein, including those payable to the individual order of the person whose name appears thereon as signer, when bearing or purporting to bear the facsimile signature of the Supervisor, and BE IT FURTHER

RESOLVED, that HSBC Bank (Cheektowaga Office), Bank of America (Dick Road Office), Key Bank (Cheektowaga Office), JP Morgan Chase Bank, N.A. (Buffalo Office), Citizens Bank (Cheektowaga Office), Evans National Bank and Manufacturers and Traders Trust Company (Airport Plaza Office) shall be entitled to honor and to charge the proper bank account of the Town of Cheektowaga for such checks, notes and other instruments, regardless of by whom or by what means the actual purported facsimile signature thereon maybe affixed thereto, if such signature resembles the facsimile specimen or specimens, duly certified to or filed with said banks by the Supervisor, the Town Clerk or other officers of the Town of Cheektowaga.

RESULT:	ADOPTED [UNANIMOUS]
MOVER:	Mary Holtz, Supervisor
SECONDER:	Jeff Swiatek, Councilmember
AYES:	Holtz, Jaworowicz, Swiatek, Rogowski, Zydel, Markel, Kaznowski



15. RESOLUTION 2011-15

Notice to Bidders - One (1) New and Unused 2011 Ford F250 Super Duty 4X4 Crew Cab with a 6 3/4 Box or Equal

Sponsored By: Supervisor Holtz, Councilmember Swiatek

WHEREAS, The Town Clerk be and hereby is directed to publish a Notice to Bidders for the purchase of ONE (1) NEW AND UNUSED 2011 FORD F250 SUPER DUTY 4X4 CREW CAB WITH A 6 3/4 BOX OR EQUAL by the Highway Department.

Information for bidders and specifications may be obtained from the Office of the Town Clerk, Cheektowaga Town Hall, Broadway and Union Roads, Cheektowaga, New York, between the hours of 9:00 AM and 4:30 PM, Monday through Friday, NOW THEREFORE, BE IT

RESOLVED, that the Town Clerk is hereby designated as the Officer to open bids on the aforesaid items at a public bid opening to be held on January 19, 2011 at 11:00AM, in the Council Chambers of the Cheektowaga Town Hall.

TOWN OF CHEEKTOWAGA HIGHWAY DEPARTMENT
LEGAL NOTICE TO BIDDERS

NOTICE IS HEREBY GIVEN, that the Town of Cheektowaga Highway Department will receive bids for the purchase of One (1), New and Unused, 2011 Ford F250 Super Duty 4x4 Crew Cab with a 6 3/4' Box or Equal for use by the Highway Department in the Town of Cheektowaga at a public bid opening to be held in the Council Chambers at the Cheektowaga Town Hall on January 19, 2011 at 11:00 A.M.

Information for bidders and specifications may be obtained from the office of Town Clerk at her office located at Town Hall, Cheektowaga NY. Bids must be enclosed in an opaque envelope plainly marked "BID FOR ONE (1) NEW AND UNUSED 2011 FORD F250 SUPER DUTY 4x4 CREW CAB WITH A 6 3/4 BOX OR EQUAL. Non-Collusion forms must be signed and submitted with each bid. The Superintendent of Highways may reject any or all bids submitted.

ALICE MAGIERSKI, TOWN CLERK

DATE: January 3, 2011
PUBLISHED: January 6, 2011

Table with 2 columns: Label (RESULT, MOVER, SECONDER, AYES) and Value (ADOPTED [UNANIMOUS], Mary Holtz, Supervisor, Jeff Swiatek, Councilmember, Holtz, Jaworowicz, Swiatek, Rogowski, Zydel, Markel, Kaznowski)



16. RESOLUTION 2011-16

Authorize Town Clerk/Receiver of Taxes to Invest Tax Moneys

Sponsored By: Supervisor Holtz, Councilmember Jaworowicz

WHEREAS, the Town of Cheektowaga through and by its Receiver of Taxes and Assessments/Town Clerk, receives and collects Town taxes, and

WHEREAS, it is advantageous to the Town to invest these moneys in short-term savings accounts, certificates of deposit, municipal re-purchase agreements, etc., thereby creating revenues for the Town, and

WHEREAS, the Town Receiver of Taxes and Assessments/Town Clerk is knowledgeable about the methods of investment and institutions in which investments can be made, and

WHEREAS, the New York State Comptroller's Office has stated in Opinion Number 80-242, that a Town Board may authorize its Receiver of Taxes and Assessments to temporarily invest town tax moneys, and

WHEREAS, the County of Erie has also authorized the Receiver of Taxes and Assessments/Town Clerk to invest County tax moneys which the Town collects and to retain any interest therefrom to the Town's credit, NOW, THEREFORE, BE IT

RESOLVED, that Alice Magierski, Town Clerk/Receiver of Taxes and Assessments for the Town of Cheektowaga, be and hereby is authorized to invest real property tax moneys on a short-term basis, and BE IT FURTHER

RESOLVED, that any interest earned on such Town or County tax moneys shall be turned over to the Town of Cheektowaga General Fund.

RESULT:	ADOPTED [UNANIMOUS]
MOVER:	Mary Holtz, Supervisor
SECONDER:	Patricia Jaworowicz, Councilmember
AYES:	Holtz, Jaworowicz, Swiatek, Rogowski, Zydel, Markel, Kaznowski



17. RESOLUTION 2011-17

Establish Salary for Deputy Town Clerk

Sponsored By: Supervisor Holtz, Councilmember Swiatek

BE IT RESOLVED, that the annual salary for the position of Deputy Town Clerk for calendar year 2011 be and hereby is established at \$42,000.00.

RESULT:	ADOPTED [UNANIMOUS]
MOVER:	Mary Holtz, Supervisor
SECONDER:	Jeff Swiatek, Councilmember
AYES:	Holtz, Jaworowicz, Swiatek, Rogowski, Zydel, Markel, Kaznowski



18. RESOLUTION 2011-18

Authorize Supervisor to Execute Grant Application for Records Center

Sponsored By: Supervisor Holtz, Councilmember Jaworowicz

WHEREAS, the Town of Cheektowaga seeks grant monies from the New York State Education Department State Archives Local Government Records Management Improvement Fund to enhance access to Town records; and

WHEREAS, the Town of Cheektowaga wishes to purchase shelving and archival boxes to house records at the Town Archives, transfer degraded microfilm to a more stable format of microfilm, and retain a professional librarian on a contractual basis to prepare eight record series for uploading to the State Archives for accessibility to researchers throughout the world; NOW, THEREFORE BE IT

RESOLVED, that Grantmakers Advantage, Inc., the Town's grant consultants, be authorized and directed to complete the necessary application, forms, etc. to be submitted to the New York State Education Department State Archives for the purpose of securing this grant, and BE IT FURTHER

RESOLVED, that the Supervisor and Town Clerk be and hereby are authorized and directed to execute all documents pertaining to the application and acquisition of said funding.

RESULT:	ADOPTED [UNANIMOUS]
MOVER:	Mary Holtz, Supervisor
SECONDER:	Patricia Jaworowicz, Councilmember
AYES:	Holtz, Jaworowicz, Swiatek, Rogowski, Zydel, Markel, Kaznowski



19. RESOLUTION 2011-19

Authorize Supervisor to Execute Agreement Regarding Installation of Fire Hydrant on Harlem Road

Sponsored By: Councilmember Kaznowski, Councilmember Zydel

WHEREAS, Reimann & Georger Corporation (the "Corporation") is the owner of premises located at 1849 Harlem Road in the Town of Cheektowaga; and

WHEREAS, the Corporation is in the process of constructing a 2,757 square foot addition to their manufacturing facility on said premises (the "Project"); and

WHEREAS, the Project requires the construction of an additional fire hydrant to service the premises; and

WHEREAS, in order to induce Reimann & Georger Corporation to proceed with the work, the Town has directed the Erie County Water Authority to install a fire hydrant in front of the building located at 1849 Harlem Road, as more particularly described and shown in said proposed Agreement; and

WHEREAS, the Company has agreed to pay the Town for any annual fee imposed by the Erie County Water Authority with respect to said hydrant, which fee is to be determined by the Water Authority; and

WHEREAS, this Town Board approves of the foregoing and is willing to enter into an agreement with the Corporation; NOW, THEREFORE, BE IT

RESOLVED, that the Supervisor be and hereby is authorized and directed to execute the aforementioned agreement on behalf of the Town of Cheektowaga, subject to approval by the Town Attorney's Office.

RESULT:	ADOPTED [UNANIMOUS]
MOVER:	Stanley Kaznowski, Councilmember
SECONDER:	Richard Zydel, Councilmember
AYES:	Holtz, Jaworowicz, Swiatek, Rogowski, Zydel, Markel, Kaznowski



20. RESOLUTION 2011-20

Direct Erie County Water Authority to Install Fire Hydrant at 1849 Harlem Road

Sponsored By: Councilmember Kaznowski, Councilmember Zydel

WHEREAS, Reimann & Georger Corporation, the owner of property located at 1849 Harlem Road, has requested the installation of a fire hydrant on or near 1849 Harlem Road to accommodate the construction of an addition to its manufacturing facility; and

WHEREAS, Forks Fire District No. 3 has reviewed this request and has no objection to same; NOW, THEREFORE, BE IT

RESOLVED, that the Erie County Water Authority be and hereby is directed to install a fire hydrant on premises located at 1849 Harlem Road, in front of the building at 1849 Harlem Road; and BE IT FURTHER

RESOLVED, that the Town of Cheektowaga shall be responsible to the Erie County Water Authority for annual hydrant rental fees for this hydrant, and BE IT FURTHER

RESOLVED, that such fees shall be reimbursed to the Town pursuant to a separate agreement with the owner; and BE IT FURTHER

RESOLVED, that the Town Clerk is directed to forward a certified copy of this resolution to:

Mr. Daniel Seider
Distribution Engineer
Erie County Water Authority
3030 Union Road
Cheektowaga, New York 14227.

RESULT:	ADOPTED [UNANIMOUS]
MOVER:	Stanley Kaznowski, Councilmember
SECONDER:	Richard Zydel, Councilmember
AYES:	Holtz, Jaworowicz, Swiatek, Rogowski, Zydel, Markel, Kaznowski



21. RESOLUTION 2011-21

Agreement with Village of Depew Re: Tax Credit for Police Services

Sponsored By: Councilmember Jaworowicz, Supervisor Holtz

WHEREAS, Section 150 of the Town Law grants discretionary authority to a town for entry into an agreement with a village located partially within its boundaries having a police department of four (4) or more police officers on an annual full-time basis, to determine what part of the cost of the town police department shall be assessed against the property in the village, and

WHEREAS, the Village of Depew is located partially within the boundaries of the Town of Cheektowaga, and, in addition, the Village of Depew maintains a police department on an annual full-time basis, and

WHEREAS, the annual budget of the Town for the fiscal year beginning January 1, 2011 provides for a credit of \$390,000.00 to the Village of Depew for the cost of the Town Police Department assessed against the property in the Village of Depew, and

WHEREAS, a proposed agreement with the Village of Depew on the matter of the aforementioned credit has been prepared and reviewed, NOW, THEREFORE, BE IT

RESOLVED, that the aforesaid agreement is approved, and the Supervisor be and hereby is authorized and directed to execute same on behalf of the Town.

RESULT:	ADOPTED [UNANIMOUS]
MOVER:	Patricia Jaworowicz, Councilmember
SECONDER:	Mary Holtz, Supervisor
AYES:	Holtz, Jaworowicz, Swiatek, Rogowski, Zydel, Markel, Kaznowski



22. RESOLUTION 2011-22

Approve Auction of Surplus Miscellaneous Equipment

Sponsored By: Supervisor Holtz, Councilmember Markel

WHEREAS, the Town wishes to dispose of miscellaneous equipment formerly used in the Town Print Shop, which is no longer needed for Town Use; and

WHEREAS, the sale of surplus property by the Town is authorized by Section 64 of the Town Law of the State of New York; and

WHEREAS, Auctions International, Inc., will sell such miscellaneous equipment at an on-line auction in accordance with the terms of a proposed contract; NOW THEREFORE, BE IT

RESOLVED, that the Town hereby retains Auctions International, Inc., 808 Borden Road, Cheektowaga, New York, as per the contract, to conduct a sale of the surplus Town equipment identified on the attached list at an on-line auction to be held on its website; and BE IT FURTHER

RESOLVED, that the Supervisor of the Town of Cheektowaga be and hereby is authorized to execute the aforementioned contract and any and all documents that may be required to effectuate the sale and transfer of all said equipment.

ATTACHMENTS:

List Misc. Equipment Reso. #4925 (PDF)

RESULT: ADOPTED [UNANIMOUS]

MOVER: Mary Holtz, Supervisor

SECONDER: Charles Markel, Councilmember

AYES: Holtz, Jaworowicz, Swiatek, Rogowski, Zydel, Markel, Kaznowski



23. RESOLUTION 2011-23

Purchase of Builders Risk Insurance for Police & Court Building Project

Sponsored By: Councilmember Swiatek, Supervisor Holtz

WHEREAS, the Town of Cheektowaga is in the process of remodeling the existing Police & Court building and constructing an addition to said building, and

WHEREAS, the Town's insurance consultant solicited quotations for builders risk coverage for this project, and

WHEREAS, One Beacon has submitted a quote for \$10,807 for said builders risk insurance, NOW, THEREFORE, BE IT

RESOLVED, that this Town Board hereby agrees to purchase builders risk coverage for the Police/Court building project through One Beacon Insurance at a cost of \$10,807, and BE IT FURTHER

RESOLVED, that funds for said insurance shall be appropriated from budget line item 101.1710.4101.

RESULT:	ADOPTED [UNANIMOUS]
MOVER:	Jeff Swiatek, Councilmember
SECONDER:	Mary Holtz, Supervisor
AYES:	Holtz, Jaworowicz, Swiatek, Rogowski, Zydel, Markel, Kaznowski



24. RESOLUTION 2011-24

Purchase of Excess Workers Compensation Insurance

Sponsored By: Supervisor Holtz, Councilmember Swiatek

WHEREAS, the Town's excess workers compensation insurance has expired, and

WHEREAS, the Town's insurance consultant solicited quotations for said excess workers compensation insurance, and

WHEREAS, Safety National Casualty Corporation, through Gallagher Bassett, has submitted a quote for coverage with a \$500,000 retention for Police and a \$450,000 retention for other departments at a cost of \$69,026, NOW, THEREFORE, BE IT

RESOLVED, that this Town Board hereby agrees to purchase excess workers compensation insurance with a \$500,000 retention for Police and a \$450,000 retention for other departments from Safety National Casualty Corporation through Gallagher Bassett at a cost of \$69,026, and BE IT FURTHER

RESOLVED, that funds for said insurance shall be appropriated from budget line item 101.1722.4519.

RESULT:	ADOPTED [UNANIMOUS]
MOVER:	Mary Holtz, Supervisor
SECONDER:	Jeff Swiatek, Councilmember
AYES:	Holtz, Jaworowicz, Swiatek, Rogowski, Zydel, Markel, Kaznowski



25. RESOLUTION 2011-25

Retain Outside Accounting Consultant for 2011-2014

Sponsored By: Holtz, Swiatek, Jaworowicz, Rogowski, Zydel, Markel, Kaznowski

WHEREAS, the Town Board desires the services of a Certified Public Accounting firm that is knowledgeable of New York State, Federal and Town rules and regulations; knowledgeable of the New York State Uniform System of Accounting for towns; experienced in implementing Governmental Accounting Standards Board (GASB) Statements; established as Government Finance Officer Association Certificate Program reviewers; and familiar with the Town's policies, accounting procedures and operations in order to effectively and efficiently perform services in the areas of:

- A. Annual Audit - A complete financial audit of the Town's basic financial statements for the year ended December 31, 2010 and years ending December 31, 2011, 2012 and 2013.
- B. Compilation of the Annual Update Document to the Office of the State Comptroller of New York records for the year ended December 31, 2010, and years ending December 31, 2011, 2012 and 2013.
- C. Compilation of financial statements from the Town's records for the year ended December 31, 2010, and years ending December 31, 2011, 2012 and 2013.
- D. Preparation of management letter relating to observations during the audit of the basic financial statements.
- E. Single Audit - Conduct an audit of Town's federal financial assistance for compliance with applicable federal laws and regulations in accordance with OMB Circular A-133 for the year ended December 31, 2010, and years ending December 31, 2011, 2012 and 2013.
- F. Other Services B Including routine consultation will be provided to the Supervisor, Town Board and the Town's Director of Administration and Finance on areas such as: GASB implementations, state revenue sharing, borrowings, federal and state legislative developments, retirement, sales tax, compilation of various sewer billings and other areas as requested.
- G. Budget Compilation B Assistance and alternatives will be provided to the Supervisor, the Town Board and the Town's Director of Administration and Finance in various phases of the compilation of the 2012-2015 benefit basis and ad valorem budgets. Will assist/advise in the compilation of the Town's 2012-2015 tax rates for submission to Erie County.
- H. Audit of Departments. Audit the cash receipts and cash disbursements of the Tax Receiver, Town Clerk, Town Justices (2), the Parks, Recreation and Youth Services Department and the Senior Services Department for the year ended December 31, 2010, and years ending December 31, 2011, 2012 and 2013.
- I. Comprehensive Annual Financial Report - Will compile the Comprehensive Annual Financial Report for the year ended December 31, 2010, and years ending December

31, 2011, 2012 and 2013 to be submitted to the Government Finance Officer's Association for review in the Certificate of Excellence in Financial Reporting Program.

- J. Compilation of Detailed Budget Presentation Document B Will compile the Town's 2012-2015 Budget Documents including departmental descriptions of pertinent responsibilities to the taxpayers, historical trends including year over year expenditure comparisons over the last three years, a table of contents and an index, and various colored charts and graphs.

and,

WHEREAS, Drescher and Malecki, LLP possesses the aforementioned attributes and is available to perform the services listed above, and

WHEREAS, this Town Board desires to retain the services of Drescher and Malecki, LLP to perform the services listed above, NOW, THEREFORE, BE IT

RESOLVED, that Drescher and Malecki, LLP be retained to perform the aforementioned services for the Town of Cheektowaga for the years 2011-2014 (which would entail the audits for the year ending December 31, 2010-2013) for a fee not to exceed \$100,500.00 each year.

RESULT:	ADOPTED [UNANIMOUS]
MOVER:	Mary Holtz, Supervisor
SECONDER:	Jeff Swiatek, Councilmember
AYES:	Holtz, Jaworowicz, Swiatek, Rogowski, Zydel, Markel, Kaznowski



26. RESOLUTION 2011-26

Authorize Supervising Code Enforcement Officer to Distribute Keys for Knox Boxes to Fire Districts

Sponsored By: Zydell, Holtz, Swiatek, Jaworowicz, Markel, Kaznowski

WHEREAS, the Codes of the State of New York empower the Town Supervising Code Enforcement Officer to require a key box to be installed on various commercial buildings, and

WHEREAS, the Town Supervising Code Enforcement Officer, in response to the request from the fire districts in the Town, requires these key boxes on newly constructed commercial buildings and commercial buildings when substantial renovations are done, and

WHEREAS, these key boxes in Cheektowaga are installed on commercial buildings by the Knox Company, and

WHEREAS, the fire districts in the Town are also purchasing key boxes from the Knox Company for use on their fire trucks, which key boxes can be opened by means of an electronic signal sent by the Police Department's dispatch office, and

WHEREAS, the fire districts have also requested that the dispatch office of the Police Department be authorized to send a signal to the fire trucks upon request by an appropriate official of the fire district, and

WHEREAS, the Supervising Code Enforcement Officer has no objection to this arrangement, NOW, THEREFORE, BE IT

RESOLVED, that this Town Board hereby authorizes the Supervising Code Enforcement to accept and distribute master keys for the key boxes from the Knox Company and to distribute said keys to the Town fire districts provided the appropriate officials of the fire districts execute a release/indemnification document in a form acceptable to the Town Attorney, and BE IT FURTHER

RESOLVED, that the Police Department dispatch office be and hereby is authorized to transmit the necessary signal to open the key box on the fire truck upon the request of an authorized official of the fire district.

RESULT:	ADOPTED [UNANIMOUS]
MOVER:	Richard Zydell, Councilmember
SECONDER:	Mary Holtz, Supervisor
AYES:	Holtz, Jaworowicz, Swiatek, Rogowski, Zydell, Markel, Kaznowski



27. RESOLUTION 2011-27

Hiring/Termination of Part-Time/Seasonal Employees

Sponsored By: Councilmember Swiatek, Supervisor Holtz

BE IT RESOLVED, that the following individuals be and hereby are hired as PART-TIME EMPLOYEES in the departments listed, not to exceed nineteen (19) hours on a weekly basis, in compliance with Civil Service Laws and Regulations as well as the provisions of the Town's collective bargaining agreement between the Town of Cheektowaga and the Town of Cheektowaga Employees Association:

SENIOR SERVICES DEPARTEMENT Recreation Attendant \$8.75/hour effective 1/4/11
Christine Kasprzak, Cheektowaga, New York

POLICE DEPARTMENT Student Assistant \$7.25/hour effective 1/4/11
Emily Russillo, Cheektowaga, New York

POLICE DEPARTMENT Clerk \$7.25/hour effective 1/4/11
Anthony M. Filipski, Jr., Cheektowaga, New York
Charlene Fedyna, Cheektowaga, New York

POLICE DEPARTMENT Clerk \$7.50/hour effective 1/4/11
Katherine Edenhofer, Depew, New York

POLICE DEPARTMENT Police Attendant \$14.00/hour effective 12/22/10
Deborah Lopez, Cheektowaga, New York

BE IT FURTHER RESOLVED, that the following seasonal and/or part-time employees be and hereby are terminated as listed:

SENIOR SERVICES DEPARTMENT
Penny Crabtree effective 12/23/10

SANITATION DEPARTMENT
Dean Mertowski effective 12/15/10

POLICE DEPARTMENT
John Reimer effective 11/9/10
Corey Schanne effective 12/14/10
Joseph Skowronski effective 12/18/10

ACCOUNTING DEPARTMENT
Jaclyn Eckel effective 12/31/10

Motion by Supervisor Holtz; Seconded by Councilmember Rogowski to waive the reading of names for the following two (2) Resolutions: 2011-27 and 2011-28. Motion Carried.

RESULT:	ADOPTED [UNANIMOUS]
MOVER:	Jeff Swiatek, Councilmember
SECONDER:	Mary Holtz, Supervisor
AYES:	Holtz, Jaworowicz, Swiatek, Rogowski, Zydel, Markel, Kaznowski



28. RESOLUTION 2011-28

Youth & Recreation Transfers

Sponsored By: Councilmember Zydel, Councilmember Rogowski

BE IT RESOLVED that the individuals listed below be and hereby are hired and/or transferred, as indicated, in the Department of Youth & Recreational Services, effective January 5, 2011:

Recreation Aide - 7140.1611 - \$7.25 - Part-time
Dakota Herkey 14225

Effective Immediately:

Recreation Attendant - 7140.1630 - \$7.50 - Regular Part-time
Jada Love
Melanie Mikolajczyk

Recreation Attendant - 7140.1630 - \$7.50 -Part-time
Jessica Arana
Holly Gasiiecki

Recreation Attendant - 7140.1614 - \$9.40 - Regular Part-time
Rob Swiatkowski

Recreation Attendant - 7140.1614 - \$8.55 - Regular Part-time
Matt Gaczewski
Amanda Maconaghy

Recreation Attendant - 7140.1614 - \$8.30 - Regular Part-time
Lauren Miller

Recreation Attendant - 7140.1614 - \$8.25 - Regular Part-time
Paige Melin

Recreation Attendant - 7140.1614 - \$7.75 - Regular Part-time
Samantha Sieg

Recreation Aide - 7140.1614 - \$7.60 - Part-time
Matthew Koszuta

RESULT:	ADOPTED [UNANIMOUS]
MOVER:	Richard Zydel, Councilmember
SECONDER:	James Rogowski, Councilmember
AYES:	Holtz, Jaworowicz, Swiatek, Rogowski, Zydel, Markel, Kaznowski



29. RESOLUTION 2011-29

Reappoint Chairman of Zoning Board

Sponsored By: Markel, Kaznowski, Holtz, Swiatek, Rogowski, Jaworowicz, Zydel

WHEREAS, the term of the Chairman of the Zoning Board of Appeals expired on December 31, 2010, and

WHEREAS, Robert Brandon has been serving as Chairman of the Planning Board, and

WHEREAS, this Board desires to reappoint Robert Brandon as Chairman of the Zoning Board of Appeals, NOW, THEREFORE, BE IT

RESOLVED, that Robert Brandon of Cheektowaga, New York be and hereby is reappointed to the position of Chairman of the Zoning Board of Appeals, effective January 1, 2011 to December 31, 2013.

RESULT:	ADOPTED [UNANIMOUS]
MOVER:	Charles Markel, Councilmember
SECONDER:	Stanley Kaznowski, Councilmember
AYES:	Holtz, Jaworowicz, Swiatek, Rogowski, Zydel, Markel, Kaznowski



30. RESOLUTION 2011-30

Reappointment to Zoning Board

Sponsored By: Markel, Kaznowski, Holtz, Swiatek, Jaworowicz, Rogowski, Zydel

WHEREAS, the term of John Abraham as Member of the Zoning Board of Appeals expired on December 31, 2010, and

WHEREAS, John Abraham has expressed an interest in being reappointed to this position, and

WHEREAS, John Abraham has satisfactorily served as Member of the Zoning Board of Appeals for a number of years and merits reappointment to such position, NOW, THEREFORE, BE IT

RESOLVED, that John Abraham of Depew, New York be and hereby is reappointed to the position of Member of the Zoning Board of Appeals, effective January 1, 2011 and terminating on December 31, 2015.

RESULT:	ADOPTED [UNANIMOUS]
MOVER:	Charles Markel, Councilmember
SECONDER:	Stanley Kaznowski, Councilmember
AYES:	Holtz, Jaworowicz, Swiatek, Rogowski, Zydel, Markel, Kaznowski



31. RESOLUTION 2011-31

Reappointment of Bingo Inspectors

Sponsored By: Holtz, Jaworowicz, Swiatek, Rogowski, Zydel, Markel, Kaznowski

BE IT RESOLVED, that the following individuals be and hereby are reappointed as Bingo Inspectors, effective January 1, 2011 to December 31, 2011:

- Katherine Ferdinand, Cheektowaga, New York
- Dennis Smith, Cheektowaga, New York
- Anthony Prep, Cheektowaga, New York

and BE IT FURTHER

RESOLVED, that the following individual be and hereby is reappointed Bingo Inspector Chairman, effective January 1, 2011 for a term of one year:

- Thaddeus I. Marciniak, Cheektowaga, New York

RESULT:	ADOPTED [UNANIMOUS]
MOVER:	Mary Holtz, Supervisor
SECONDER:	Patricia Jaworowicz, Councilmember
AYES:	Holtz, Jaworowicz, Swiatek, Rogowski, Zydel, Markel, Kaznowski



32. RESOLUTION 2011-32

Reappointment of Library Board Member

Sponsored By: Holtz, Jaworowicz, Swiatek, Rogowski, Zydel, Markel, Kaznowski

WHEREAS, the term of Deborah Cope as Member of the Cheektowaga Public Library Board expired on December 31, 2010, and

WHEREAS, Deborah Cope has requested reappointment to the Cheektowaga Library Board, and

WHEREAS, the Cheektowaga Library Board has recommended that Deborah Cope be reappointed as member of the Cheektowaga Library Board, NOW, THEREFORE, BE IT

RESOLVED, that Deborah Cope, of Cheektowaga, New York be and hereby is reappointed to the position of Member of the Cheektowaga Public Library Board, effective January 1, 2011 and terminating on December 31, 2015.

RESULT:	ADOPTED [UNANIMOUS]
MOVER:	Mary Holtz, Supervisor
SECONDER:	Patricia Jaworowicz, Councilmember
AYES:	Holtz, Jaworowicz, Swiatek, Rogowski, Zydel, Markel, Kaznowski



33. RESOLUTION 2011-33

Reappointments to Traffic Safety Commission

Sponsored By: Zydel, Markel, Holtz, Swiatek, Jaworowicz, Rogowski, Kaznowski

WHEREAS, the terms of Cheektowaga Traffic Safety Commission Vice Chairman Paul Gasiewicz, Treasurer Thaddeus Skowron and Member Charles Getz expired on December 31, 2010, and

WHEREAS, Paul Gasiewicz, Thaddeus Skowron and Charles Getz have expressed an interest in continuing to serve on the Traffic Safety Commission, and

WHEREAS, the Traffic Safety Commission has recommended that the aforesaid individuals be re-appointed to the Traffic Safety Commission, NOW, THEREFORE, BE IT

RESOLVED, that the following individuals be and hereby are re-appointed as to the Traffic Safety Commission, effective immediately and terminating on December 31, 2013:

Paul Gasiewicz, Vice Chairman
Thaddeus Skowron, Treasurer
Charles Getz, Member

RESULT:	ADOPTED [UNANIMOUS]
MOVER:	Richard Zydel, Councilmember
SECONDER:	Charles Markel, Councilmember
AYES:	Holtz, Jaworowicz, Swiatek, Rogowski, Zydel, Markel, Kaznowski



34. RESOLUTION 2011-34

Appointments to Planning Board

Sponsored By: Markel, Kaznowski, Holtz, Swiatek, Jaworowicz, Rogowski, Zydel

WHEREAS, there are two (2) vacancies in the position of Member of the Cheektowaga Planning Board, and

WHEREAS, Joan Adams and Ruth Casacci have expressed an interest in serving as Member of the Planning Board, and

WHEREAS, this Town Board has reviewed the letters submitted by various applicants for these positions, NOW, THEREFORE, BE IT

RESOLVED, that this Town Board determines that the following individuals meet the qualifications for Member of the Planning Board and hereby appoint the following individuals to the following terms:

Name	Term
Joan Adams of Cheektowaga	January 1, 2011 to December 31, 2011
Ruth Casacci of Cheektowaga	January 1, 2011 to December 31, 2015.

<p>RESULT: ADOPTED [UNANIMOUS]</p> <p>MOVER: Charles Markel, Councilmember</p> <p>SECONDER: Stanley Kaznowski, Councilmember</p> <p>AYES: Holtz, Jaworowicz, Swiatek, Rogowski, Zydel, Markel, Kaznowski</p>
--



35. RESOLUTION 2011-35

Appointments to Board of Assessment Review

Sponsored By: Jaworowicz, Holtz, Swiatek, Rogowski, Zydel, Markel, Kaznowski

WHEREAS, there are two (2) vacancies on the Board of Assessment Review caused by the resignations of Casimir A. Kozminski and Newton A. Graziano, and

WHEREAS, there is another vacancy on the Board of Assessment Review as a result of the expiration of the term of Robert E. Kaczmarek, and

WHEREAS, Patricia Krempholtz and Gerald P. Kaminski, Sr. requested appointment to said Board and are qualified for said position , and

WHEREAS, Robert E. Kaczmarek has requested reappointment as Chairman to said Board, NOW, THEREFORE, BE IT

RESOLVED, that Patricia Krempholtz of Cheektowaga, New York be and hereby is appointed to the position of member of the Cheektowaga Board of Assessment Review, effective immediately and terminating on September 30, 2012, and BE IT FURTHER

RESOLVED, that Gerald P. Kaminski, Sr. of Cheektowaga, New York be and hereby is appointed to the position of member of the Board of Assessment Review, effective immediately and terminating on September 30, 2014, and BE IT FURTHER

RESOLVED, that Robert E. Kaczmarek of Cheektowaga, New York be and hereby is reappointed as Chairman of the Board of Assessment Review, effective immediately and terminating on September 30, 2015.

RESULT:	ADOPTED [UNANIMOUS]
MOVER:	Patricia Jaworowicz, Councilmember
SECONDER:	Mary Holtz, Supervisor
AYES:	Holtz, Jaworowicz, Swiatek, Rogowski, Zydel, Markel, Kaznowski



36. RESOLUTION 2011-36

Appointments to Veterans Affairs Committee

Sponsored By: Councilmember Zydel, Councilmember Rogowski

WHEREAS, in order to keep this Town Board informed as to the needs of veterans in the Town, this Town Board created the Veterans Affairs Committee and appointed members thereto, and

WHEREAS, the members of the Veterans Affairs Committee serve for terms of one (1) year, and their terms expired on December 31, 2010, and

WHEREAS, this Board wishes to appoint the following members to a one (1) year term, NOW, THEREFORE, BE IT

RESOLVED, that the following individuals be and hereby are appointed to the Veterans Affairs Committee, effective January 1, 2011 and expiring on December 31, 2011:

- Victor Carlucci, Depew, NY
J. Donald Griffin, Cheektowaga, NY
Joseph Lipowski, Depew, NY
Sylvia Lipowski, Depew, NY
Joseph Porempski, Cheektowaga, NY
Karen Porempski, Cheektowaga, NY
Earle Rosenthal, Cheektowaga, NY
Elaine Rosenthal, Cheektowaga, NY
George Ross, Angola Lake, NY
Raymond Wolniewicz, Cheektowaga, NY
John D. Stiegler, Cheektowaga, NY
Wayne Sorrentino, Cheektowaga, NY
Thomas J. Mazur, Cheektowaga, NY
Jeff Sundquist, Depew, New York
Thomas M. Johnson, Jr., Youngstown, New York
James Burns, Lancaster, New York
Nelson Oldfield, Cheektowaga, New York

Motion by Councilmember Zydel; Seconded by Councilmember Rogowski to amend this resolution to remove Victor Carlucci and add Stanley Blake. Motion Carried.

WHEREAS, in order to keep this Town Board informed as to the needs of veterans in the Town, this Town Board created the Veterans Affairs Committee and appointed members thereto, and

WHEREAS, the members of the Veterans Affairs Committee serve for terms of one (1) year, and their terms expired on December 31, 2010, and

WHEREAS, this Board wishes to appoint the following members to a one (1) year term, NOW, THEREFORE, BE IT

RESOLVED, that the following individuals be and hereby are appointed to the Veterans Affairs Committee, effective January 1, 2011 and expiring on December 31, 2011:

J. Donald Griffin, Cheektowaga, NY
Joseph Lipowski, Depew, NY
Sylvia Lipowski, Depew, NY
Joseph Porempski, Cheektowaga, NY
Karen Porempski, Cheektowaga, NY
Earle Rosenthal, Cheektowaga, NY
Elaine Rosenthal, Cheektowaga, NY
George Ross, Angola Lake, NY
Raymond Wolniewicz, Cheektowaga, NY
John D. Stiegler, Cheektowaga, NY
Wayne Sorrentino, Cheektowaga, NY
Thomas J. Mazur, Cheektowaga, NY
Jeff Sundquist, Depew, New York
Thomas M. Johnson, Jr., Youngstown, New York
James Burns, Lancaster, New York
Nelson Oldfield, Cheektowaga, New York
Stanley Blake, Lancaster, NY

RESULT:	ADOPTED AS AMENDED [UNANIMOUS]
MOVER:	Richard Zydell, Councilmember
SECONDER:	James Rogowski, Councilmember
AYES:	Holtz, Jaworowicz, Swiatek, Rogowski, Zydell, Markel, Kaznowski

**37. RESOLUTION 2011-37****Appointment of Police Officers (Competitive/Permanent)
Police Department/ Scott R. Polino, Christopher T.
Wierzbowski, Mark P. Fatta and William E. Cookfair II**

Sponsored By: Councilmember Jaworowicz, Councilmember Markel

WHEREAS, four (4) vacancies exist in the position of Police Officer in the Town of Cheektowaga; AND

WHEREAS, the civil service list for said title has been canvassed and candidates have been interviewed; NOW, THEREFORE, BE IT

RESOLVED, that the following be and hereby are appointed to the position of Police Officer at a salary in accordance with the collective bargaining agreement between the Town of Cheektowaga and the Town of Cheektowaga Police Club:

- Scott R. Polino of Cheektowaga, New York
- Christopher T. Wierzbowski of Cheektowaga, New York
- Mark P. Fatta of Cheektowaga, New York
- William E. Cookfair II of Cheektowaga, New York

AND, BE IT FURTHER

RESOLVED, that said appointments shall become effective January 13, 2011, and are subject to verification of compliance with the Residency Law of the Town of Cheektowaga.

RESULT:	ADOPTED [UNANIMOUS]
MOVER:	Patricia Jaworowicz, Councilmember
SECONDER:	Charles Markel, Councilmember
AYES:	Holtz, Jaworowicz, Swiatek, Rogowski, Zydel, Markel, Kaznowski



38. RESOLUTION 2011-38

Travel Authorization Building Inspection & Community Development Departments

Sponsored By: Councilmember Swiatek, Supervisor Holtz

WHEREAS, the Niagara Frontier Building Officials Association Annual Conference is being held in Cheektowaga, New York from January 24 through January 26, 2011; AND

WHEREAS, Supervising Code Enforcement Officer Thomas Adamczak has requested authorization for the following employees listed to attend said conference:

- Thomas Adamczak, Supervising Code Enforcement Officer
- Lawrence Kensy, Senior Housing Inspector
- Gary Parks, Code Enforcement Officer
- Gerald Sprada, Fire Inspector
- Robert Jaroszewski, Fire Inspector
- Mark Radecki, Assistant Code Enforcement Officer
- Donald Wartinger, Housing Inspector
- Mark Bielefeld, Assistant Code Enforcement Officer
- Donald O'Neill, Assistant Plumbing Inspector
- Richard Coburn, Housing Inspector
- Gerald Gill, Housing Inspector (Part Time)
- Larry Rokitka, Housing Inspector (Part Time)
- Gregory Magnuszewski, Assistant Plumbing Inspector
- Donald Bielefeld, Assistant Code Enforcement Officer
- Daniel Lelito, Assistant Code Enforcement Officer
- Dale Parks, Housing Inspector (Community Development)
- Richard Willis, Housing Inspector (Community Development)
- Gail Milburth, Assistant Code Enforcement Officer (Community Development); AND

WHEREAS, Mr. Adamczak has submitted a request for travel authorization along with the proper paperwork in a timely manner; AND

WHEREAS, the total cost to the Town shall not exceed \$3750.00; AND

WHEREAS, these expenses have been budgeted by the Building and Plumbing Department as well as the Office of Community Development; NOW, THEREFORE, BE IT

RESOLVED, that the aforementioned employees be and hereby are approved to attend the Niagara Frontier Building Officials Association Annual Conference being held in Cheektowaga, New York from January 24 through January 26, 2011.

RESULT:	ADOPTED [UNANIMOUS]
MOVER:	Jeff Swiatek, Councilmember
SECONDER:	Mary Holtz, Supervisor

AYES: Holtz, Jaworowicz, Swiatek, Rogowski, Zydel, Markel, Kaznowski



39. RESOLUTION 2011-39

Travel Authorization Youth and Recreation Department (Program Coordinator Jillian Gorman-King)

Sponsored By: Councilmember Swiatek, Supervisor Holtz

WHEREAS, the Association of New York State Youth Bureaus Annual Youth Leadership Conference is being held February 7-8, 2011 in Albany, New York; AND

WHEREAS, Program Coordinator Jillian Gorman-King and two Cheektowaga youth have requested authorization to attend said conference; AND

WHEREAS, the Youth and Recreation Department has submitted a request for travel authorization along with the proper paperwork in a timely manner; AND

WHEREAS, the total cost to the Town shall not exceed \$450.00; AND

WHEREAS, these expenses have been budgeted by the Accounting Department;
NOW, THEREFORE, BE IT

RESOLVED, that Program Coordinator Jillian Gorman-King and two Cheektowaga youth be and hereby are authorized to attend the Association of New York State Youth Bureaus Annual Youth Leadership Conference being held February 7-8, 2011 in Albany, New York.

RESULT:	ADOPTED [UNANIMOUS]
MOVER:	Jeff Swiatek, Councilmember
SECONDER:	Mary Holtz, Supervisor
AYES:	Holtz, Jaworowicz, Swiatek, Rogowski, Zydel, Markel, Kaznowski

IV. Communications

A. Departmental Communications

1. Building Permits - December 2010
2. 2010 Central Records Management Year End Report
3. Minutes: Cheektowaga Traffic Safety Commission - November 16, 2010

B. General Communications

1. Notice of Claim: Amica Mutual Insurance for Jerald R. Barber Vs. Town of Cheektowaga
2. Notice of Claim: Paul Caban Vs. Town of Cheektowaga
3. Notice of Claim: Victor T. Carbone Vs. Town of Cheektowaga

V. Comments

A. Supervisor's Comments

B. Councilmember's Comments

C. Public Comments

VI. Adjournment

Prior to the adjournment - a Moment of Silence for two former employees: Norbert Skibinski, Building Maintenance and Paul Westphal, Sanitation Department. Motion by Supervisor Holtz; Seconded by Councilmember Rogowski to adjourn the meeting at 7:15 PM.

Alice Magierski, Town Clerk

Notice of Public Hearing
Town of Cheektowaga FY 2011 Annual Plan
Community Development Block Grant/HOME Programs

A public hearing will be held on Tuesday, January 18, 2011 at 6:45 P.M. at Cheektowaga Town Hall, 3301 Broadway, Cheektowaga, NY 14227 on the Town's Fiscal Year 2011 Annual Plan for the Community Development Block Grant (CDBG) and HOME Investment Partnership Act (HOME) Programs to obtain the views of citizens and interested parties on housing and community development needs in the Town and on the draft Action Plan which has been made available for public review in Cheektowaga Branch Libraries. The Annual Plan outlines housing and community development projects proposed to be funded with FY 2011 CDBG and HOME Program funds. The Town is eligible to receive approximately \$1,150,000 in CDBG funds and approximately \$382,500 in HOME Investment Partnership Program funds from HUD in 2011. The Town estimates approximately \$200,000 in program income from its revolving housing rehabilitation loan program and \$300,000 in economic development revolving business loan program income will be received. Those wishing to offer comments at the hearing are asked to also submit a written text, which may also be submitted to the Cheektowaga Community Development Office, 275 Alexander Avenue, Cheektowaga, New York, 14211. Interpreters will be made available at the meetings upon prior request to sign for the hearing impaired. If you need such special arrangements, contact the Cheektowaga Community Development Office at 897-7200, Ext. 6, at least seven (7) business days prior to the hearing. The hearing location is accessible to the physically disabled.

L-11183, P-2865 (document copied from deed)

PARCEL A

ALL THAT TRACT OR PARCEL OF LAND, situate in the Town of Cheektowaga, County of Erie and State of New York, being part of Lot No. 16, Township 11, Range 7 of the Holland Land Company's Survey, bounded as follows:

BEGINNING in the northwesterly line of Duke Road at the most southerly corner of lands described in a memorandum of lease to Sun Oil Company recorded in Erie County Clerk's Office in Liber 5816 of Deeds, at Page 13; running thence south 30°-27' west along said northwesterly line of Duke Road 31.18 feet to an angle in said line; thence continuing southwestwardly along the northwesterly line of Duke Road 787.34 feet to the east line of lands conveyed to Lawrence Walsh by deed recorded in Erie County Clerk's Office in Liber 255 of Deeds, at Page 112; thence northerly along said east line 707.44 feet to the north line of lands conveyed to Elijah Efner by deed recorded in Erie County Clerk's Office in Liber 232 of Deeds at Page 634; thence easterly along said north line 552.42 feet to the west line of lands leased to Sun Oil Company as described in memorandum of lease aforesaid; thence southerly along said west line of 94 feet to an angle in said line; and thence southeasterly still along lands so described 131 feet to the point of beginning.

EXCEPT THEREFROM ALL THAT TRACT OR PARCEL OF LAND situate in the Town of Cheektowaga, County of Erie and State of New York being part of Lot No. 16, Township 11, Range 7 of the Holland Land Company's survey, described as follows: Beginning in the north line of Duke Road (66 feet wide), at its intersection with the east line of lands of Lawrence Walsh described in deed recorded in Liber 255 of Deed page 112; thence northeasterly along said east line of the lands of Walsh, for a distance of 707.44 feet to the north line of lands of Elijah Efner described in deed recorded in Liber 232 of Deeds page 634; thence easterly along said north line of the lands of Elijah Efner, for a distance of 125.01 feet to a point on said north line, which is located 577.41 feet westerly of the east line of Lot No. 16: thence southwestwardly at an interior angle with the last described line of 89°-20'-58", for a distance of 610.79 feet to a point on said north line of Duke Road, distant 159.46 feet easterly of the intersection of said north line of Duke Road with said east line of the lands of Walsh as described in deed recorded in the Erie County Clerk's Office in Liber 255 of Deeds page 112: thence southwestwardly along said north line of Duke Road, for a distance of 159.46 feet to the point or place of beginning.

PARCEL B

ALL THAT CERTAIN PLOT, PIECE OR PARCEL OF LAND, situate, lying and being in the Town of Cheektowaga, County of Erie, State of New York being part of Lot number 16, Township 11, Range 7 of the Holland Land Company's Survey more particularly bounded and described as follows:

BEGINNING at the most easterly point of lands conveyed to Carlton W. Hasselback by deed recorded in the Erie County Clerk's Office in Liber 5956 of Deeds page 398, said point of beginning also being 82.54 feet westerly from the east line of Liber 6694 of Deeds page 273, as measured along the southerly highway boundary line of Walden Avenue.

RUNNING THENCE westerly along the southerly line of such land in said Liber 5956 of Deeds page 398 a distance of 289.80 feet to a point;

RUNNING THENCE northerly at right angles, a distance of 66.97 feet, (said line being 80.05 feet easterly from the southeasterly corner of the car wash structure now situated on the premises immediately adjoining on the west) to a point on the southerly highway boundary line of Walden Avenue;

RUNNING THENCE southeasterly at an interior angle of 76 degrees 59'-15" and along the said southerly line of Walden Avenue, 297.43 feet to the POINT or PLACE of BEGINNING.

417. Being the same premises described in the deed dated 6/7/68 recorded 6/7/68 in Liber 7475 Page

Attachment: 2185 Walden Avenue - Legal Description (RES-2011-11 : Call for Public Hearing - 2185 Walden Avenue)

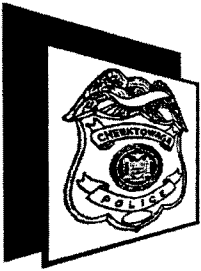

Cheektowaga Police Department

*Christine M. Ziembra
Chief of Police*

PRINT SHOP ITEMS

1. AB Dick Multi-Lith Offset model 1250
 - a. Single lever control
 - b. Additions to the machine
 - c. No Town inventory tag
 - d. Instruction booklet

2. Simplex Time Stamp Machine model HA176A
 - a. Inventory tag 02107

3. AGFA-GEVAERT Copy Rapid F-13 Platemaker
 - a. Inventory tag 02103
 - b. Diffusion transfer platemaker
 - c. Instruction booklet

4. AGFA REPROMASTER 310 CAMERA
 - a. Inventory tag 03871

5. Interlake Rapid 101 Stapler model ESS-100
 - a. With instruction booklet

6. AB Dick Platemaker model 156
 - a. Inventory tag 03876

7. Paper Cutter
 - a. Inventory tag 02101

8. Electric Punch
 - a. Inventory Tag 03849



Town of Cheektowaga

Regular Meeting

~ Minutes ~

3301 Broadway
Cheektowaga, NY 14227
<http://www.town.cheektowaga.ny.us>

Alice Magierski
716-686-3400

Tuesday, January 18, 2011

6:45 PM

Council Chambers

I. Call to Order

6:45 PM Meeting called to order on January 18, 2011 at Council Chambers, 3301 Broadway St, Cheektowaga, NY.

Attendee Name	Organization	Title	Status	Arrived
Mary Holtz	Town of Cheektowaga	Supervisor	Present	
Patricia Jaworowicz	Town of Cheektowaga	Councilmember	Present	
Jeff Swiatek	Town of Cheektowaga	Councilmember	Present	
James Rogowski	Town of Cheektowaga	Councilmember	Present	
Richard Zydel	Town of Cheektowaga	Councilmember	Present	
Charles Markel	Town of Cheektowaga	Councilmember	Present	
Stanley Kaznowski	Town of Cheektowaga	Councilmember	Present	

2. Additional Attendees

Thomas Adamczak, Supervising Building and Plumbing Inspector
Ellen Fischer, Executive Director - Youth Board
Jerry Gabryszak, Director of Community Development
Brian Krause, Director of Finance and Administration
John Marriott, Planning Board Chairman
William Pugh, Town Engineer
Kevin Schenk, Town Attorney
James Speyer, Captain, Cheektowaga Police Department
Mark Wegner, Highway Superintendent

II. Public Comment Period

III. Public Hearings

1. Community Development Block Grant Program

This being the time and place advertised for a Public Hearing, the Supervisor directed the Town Clerk to present that such notice has been duly published and posted; upon the order of the Supervisor such proof was duly filed.

The Supervisor announced that the Town Board would hear all persons interested in the subject of the hearing. Comments were heard, after which the Supervisor declared the hearing closed, decision was reserved.

RESULT: CLOSED [UNANIMOUS]
MOVER: Patricia Jaworowicz, Councilmember

SECONDER: Richard Zydel, Councilmember
AYES: Holtz, Jaworowicz, Swiatek, Rogowski, Zydel, Markel, Kaznowski

2. Rezoning of 2185 Walden Avenue

This being the time and place advertised for a Public Hearing, the Supervisor directed the Town Clerk to present that such notice has been duly published and posted; upon the order of the Supervisor such proof was duly filed.

The Supervisor announced that the Town Board would hear all persons interested in the subject of the hearing. Comments were heard, after which the Supervisor declared the hearing closed, decision was reserved.

RESULT: **CLOSED [UNANIMOUS]**
MOVER: Charles Markel, Councilmember
SECONDER: Stanley Kaznowski, Councilmember
AYES: Holtz, Jaworowicz, Swiatek, Rogowski, Zydel, Markel, Kaznowski

IV. Resolutions



1. RESOLUTION 2011-40

Transfer of Funds

Sponsored By: Supervisor Holtz, Councilmember Swiatek

2010

BE IT RESOLVED, that the following transfer is hereby approved and made a part hereof;

GENERAL FUND

FROM:	100.1320.4145	Professional Services	\$ 1,490.00
TO:	100.1220.4957	Grant Development	\$ 1,490.00

RESULT:	ADOPTED [UNANIMOUS]
MOVER:	Mary Holtz, Supervisor
SECONDER:	Jeff Swiatek, Councilmember
AYES:	Holtz, Jaworowicz, Swiatek, Rogowski, Zydel, Markel, Kaznowski



2. RESOLUTION 2011-41

Warrant

Sponsored By: Supervisor Holtz, Councilmember Swiatek

BE IT RESOLVED, that the following Vouchers & Warrants submitted to the Town of Cheektowaga prior to January 14, 2011 are hereby approved and made a part hereof;

GENERAL FUND	\$ 3,475,965.46
RISK RETENTION FUND	112,387.81
DEBT SERVICE FUND	74,634.70
HUD HOUSING REHABILITATION FUND	6,487.00
SPECIAL DISTRICTS FUND	1,166,824.00
HIGHWAY FUND	818,664.79
CAPITAL FUND	111,530.24
TRUST & AGENCY FUND	18,192.06
HUD CDBG FUND	94,817.17
PART TOWN FUND	170,199.79
NYS AFFORDABLE HOUSING	5,830.00
	<u>\$ 6,055,533.02</u>

RESULT: **ADOPTED [UNANIMOUS]**

MOVER: Mary Holtz, Supervisor

SECONDER: Jeff Swiatek, Councilmember

AYES: Holtz, Jaworowicz, Swiatek, Rogowski, Zydel, Markel, Kaznowski



3. RESOLUTION 2011-42

Amend 2010 Community Development Annual Plan

Sponsored By: Councilmember Markel, Councilmember Kaznowski

WHEREAS, the Town of Cheektowaga has received Community Development Block Grant funds from the Department of Housing & Urban Development, and

WHEREAS, the Town wishes to amend its Annual Community Development Block Grant Action Plan for the 2010 program year pursuant to the notice on Community Development Block Grant Program Amendment Report, and

WHEREAS, citizens and interested parties were provided the opportunity to comment on the proposed amendment pursuant to the Citizen Participation Plan previously adopted by the Town Board, and

WHEREAS, the Director of Community Development recommends approval of the proposed amendments, NOW THEREFORE BE IT

RESOLVED, that the Town Board hereby amends the Town of Cheektowaga's Annual Plan / Final Statement on the Use of Community Development Block Grant Funds for the 2010 program year pursuant to the notice on Community Development Block Grant Final Statement Amendment Report.

Town of Cheektowaga
Community Development Block Grant Program
Annual Plan / Final Statement Amendment Report
2010 - #3

The Town of Cheektowaga has amended its Final Statement/Annual Plan on the Use of Community Development Block Grant funds as follows: (a) the Program Year 2010 Senior Citizen Wheelchair Van activity has been cancelled; and, (b) a new activity entitled Senior Citizen Center Accessible Bathroom has been created. The new activity will add a bathroom accessible to physically disabled individuals in the east wing of the Cheektowaga Senior Citizen Center. Funds in the amount of \$18,000 will be transferred from the cancelled activity to the new activity.

RESULT:	ADOPTED [UNANIMOUS]
MOVER:	Charles Markel, Councilmember
SECONDER:	Stanley Kaznowski, Councilmember
AYES:	Holtz, Jaworowicz, Swiatek, Rogowski, Zydel, Markel, Kaznowski



4. RESOLUTION 2011-43

Notice of Hearing for Demolition of 24E Glenwood Court

Sponsored By: Councilmember Markel, Councilmember Kaznowski

WHEREAS, the Supervising Code Enforcement Officer has received information that the residential building located at 24E Glenwood Court in the Town of Cheektowaga has become dangerous and unsafe to the general public and unfit for the purposes for which it may lawfully be used; and

WHEREAS, said building has been inspected and a written report of the condition has been completed by Nussbaumer & Clarke, Inc., duly authorized agent of the Town of Cheektowaga, setting forth its findings and recommendations in regard to the repair or demolition and removal of the building, and said written report describes extensive deterioration and damage to the building and premises and recommends that the building be demolished and removed; and

WHEREAS, the Town Board has fully considered such written report and has determined that the building is dangerous and unsafe to the general public and unfit for the purposes for which it may lawfully be used; NOW THEREFORE BE IT

RESOLVED, that this Town Board accepts the findings and recommendations of Nussbaumer & Clarke, Inc., dated December 16, 2010, and BE IT FURTHER

RESOLVED, that a notice shall be served, pursuant to Section 75-7 of the Cheektowaga Town Code, upon the owner, executor, administrator, agent, lessee or any person having a vested or contingent interest in such unsafe building as shown by the records of the Receiver of Taxes or of the County Clerk, which notice shall have the contents prescribed by Section 75-6 of said Town Code, including, but not limited to, a date, time and place for a hearing before the Town Board in relation to such dangerous and unsafe building, which hearing shall be scheduled not less than five business days from the date of service of the notice, and BE IT FURTHER

RESOLVED, that a hearing before this Board in relation to the dangerous and unsafe building at 24E Glenwood Court shall be held on the 7th day of February, 2011, 6:45 P.M. at the Cheektowaga Town Hall, 3301 Broadway, Cheektowaga, New York, and BE IT FURTHER

RESOLVED, that the Code Enforcement Office and/or the Town Attorney's Office be and hereby is directed to serve notice of said hearing on all interested parties.

RESULT:	ADOPTED [UNANIMOUS]
MOVER:	Charles Markel, Councilmember
SECONDER:	Stanley Kaznowski, Councilmember
AYES:	Holtz, Jaworowicz, Swiatek, Rogowski, Zydel, Markel, Kaznowski



5. RESOLUTION 2011-44

Notice of Hearing for Demolition of 89 Gardenvale Drive

Sponsored By: Councilmember Markel, Councilmember Kaznowski

WHEREAS, the Supervising Code Enforcement Officer has received information that the residential building located at 89 Gardenvale Drive in the Town of Cheektowaga has become dangerous and unsafe to the general public and unfit for the purposes for which it may lawfully be used; and

WHEREAS, said building has been inspected and a written report of the condition has been completed by Nussbaumer & Clarke, Inc., duly authorized agent of the Town of Cheektowaga, setting forth its findings and recommendations in regard to the repair or demolition and removal of the building, and said written report describes extensive deterioration and damage to the building and premises and recommends that the building be demolished and removed; and

WHEREAS, the Town Board has fully considered such written report and has determined that the building is dangerous and unsafe to the general public and unfit for the purposes for which it may lawfully be used; NOW THEREFORE BE IT

RESOLVED, that this Town Board accepts the findings and recommendations of Nussbaumer & Clarke, Inc., dated December 15, 2010, and BE IT FURTHER

RESOLVED, that a notice shall be served, pursuant to Section 75-7 of the Cheektowaga Town Code, upon the owner, executor, administrator, agent, lessee or any person having a vested or contingent interest in such unsafe building as shown by the records of the Receiver of Taxes or of the County Clerk, which notice shall have the contents prescribed by Section 75-6 of said Town Code, including, but not limited to, a date, time and place for a hearing before the Town Board in relation to such dangerous and unsafe building, which hearing shall be scheduled not less than five business days from the date of service of the notice, and BE IT FURTHER

RESOLVED, that a hearing before this Board in relation to the dangerous and unsafe building at 89 Gardenvale Drive shall be held on the 7th day of February, 2011, 6:45 P.M. at the Cheektowaga Town Hall, 3301 Broadway, Cheektowaga, New York, and BE IT FURTHER

RESOLVED, that the Code Enforcement Office and/or the Town Attorney's Office be and hereby is directed to serve notice of said hearing on all interested parties.

RESULT:	ADOPTED [UNANIMOUS]
MOVER:	Charles Markel, Councilmember
SECONDER:	Stanley Kaznowski, Councilmember
AYES:	Holtz, Jaworowicz, Swiatek, Rogowski, Zydel, Markel, Kaznowski



6. RESOLUTION 2011-45

Notice of Hearing for Demolition of 27 Alpine Place

Sponsored By: Councilmember Markel, Councilmember Kaznowski

WHEREAS, the Supervising Code Enforcement Officer has received information that the residential building located at 27 Alpine Place in the Town of Cheektowaga has become dangerous and unsafe to the general public and unfit for the purposes for which it may lawfully be used; and

WHEREAS, said building has been inspected and a written report of the condition has been completed by Nussbaumer & Clarke, Inc., duly authorized agent of the Town of Cheektowaga, setting forth its findings and recommendations in regard to the repair or demolition and removal of the building, and said written report describes extensive deterioration and damage to the building and premises and recommends that the building be demolished and removed; and

WHEREAS, the Town Board has fully considered such written report and has determined that the building is dangerous and unsafe to the general public and unfit for the purposes for which it may lawfully be used; NOW THEREFORE BE IT

RESOLVED, that this Town Board accepts the findings and recommendations of Nussbaumer & Clarke, Inc., dated December 16, 2010, and BE IT FURTHER

RESOLVED, that a notice shall be served, pursuant to Section 75-7 of the Cheektowaga Town Code, upon the owner, executor, administrator, agent, lessee or any person having a vested or contingent interest in such unsafe building as shown by the records of the Receiver of Taxes or of the County Clerk, which notice shall have the contents prescribed by Section 75-6 of said Town Code, including, but not limited to, a date, time and place for a hearing before the Town Board in relation to such dangerous and unsafe building, which hearing shall be scheduled not less than five business days from the date of service of the notice, and BE IT FURTHER

RESOLVED, that a hearing before this Board in relation to the dangerous and unsafe building at 27 Alpine Place shall be held on the 7th day of February, 2011, 6:45 P.M. at the Cheektowaga Town Hall, 3301 Broadway, Cheektowaga, New York, and BE IT FURTHER

RESOLVED, that the Code Enforcement Office and/or the Town Attorney's Office be and hereby is directed to serve notice of said hearing on all interested parties.

RESULT:	ADOPTED [UNANIMOUS]
MOVER:	Charles Markel, Councilmember
SECONDER:	Stanley Kaznowski, Councilmember
AYES:	Holtz, Jaworowicz, Swiatek, Rogowski, Zydel, Markel, Kaznowski



7. RESOLUTION 2011-46

Notice to Bidders - Work Uniforms

Sponsored By: Councilmember Kaznowski, Councilmember Zydel

WHEREAS, it is in order that bids be advertised to cover the purchase of work uniforms for the year of 2011 for the Town of Cheektowaga, AND

WHEREAS, the Engineering Department has prepared specifications for same, NOW, THEREFORE, BE IT

RESOLVED, that the Town Clerk be directed to publish a Notice to Bidders for the furnishing of work uniforms to the Town of Cheektowaga for the year of 2011, said notice to be published in the CHEEKTOWAGA BEE, AND, BE IT FURTHER

RESOLVED, that sealed bids will be received on the 2nd day of February, 2011 at 11:00 A.M., at a public bid opening to be held in the Council Chambers in the Cheektowaga Town Hall.

NOTICE TO BIDDERS

Sealed proposals will be received and considered by the Town Board of the Town of Cheektowaga on February 2, 2011 at 11:00 A.M., at the Town Hall, corner of Broadway and Union Roads, for the furnishing of work uniforms for the 2011 calendar year.

Information for bidders and specifications may be obtained from the Town Clerk at her office in said Town.

The Town Board reserves the right to consider informal any bid not prepared and submitted in accordance with the provisions of the specifications and contract documents and may waive any informalities, make an award to other than the low bidder, should it be in the best interest of the Town, or reject any and all bids.

By order of the Town Board of the Town of Cheektowaga, Erie County, New York.

Alice Magierski
Town Clerk

DATED: January 18, 2011

RESULT:	ADOPTED [UNANIMOUS]
MOVER:	Stanley Kaznowski, Councilmember
SECONDER:	Richard Zydel, Councilmember
AYES:	Holtz, Jaworowicz, Swiatek, Rogowski, Zydel, Markel, Kaznowski



8. RESOLUTION 2011-47

Notice to Bidders - Baseball & Softball Equipment

Sponsored By: Councilmember Zydell, Councilmember Rogowski

WHEREAS it is in order that bids be advertised for the purchase of baseball and softball equipment for the Town of Cheektowaga Department of Youth and Recreational Services, BE IT

RESOLVED that the Town Clerk be directed to publish a Notice to Bidders, to be published in the CHEEKTOWAGA BEE, for the furnishing of said equipment. Information for bidders and specifications may be obtained from the office of Alice Magierski, Town Clerk, and BE IT FURTHER

RESOLVED that sealed bids will be received on February 9, 2011 at 11:00 a.m. Eastern Standard Time at a public bid opening to be held in the Town Clerk's Office located in Cheektowaga Town Hall.



NOTICE TO BIDDERS

Sealed bid proposals will be received and considered by the Town Board of the Town of Cheektowaga, publicly opened and read by the Town Clerk of the Town of Cheektowaga, Erie County, New York, on February 9, 2011 at 11:00 a.m. Eastern Standard Time at Town Hall, corner of Broadway and Union Road for the purchase of baseball and softball equipment.

Information for bidders and specifications may be obtained from the Town Clerk at her office located in the Cheektowaga Town Hall. One bid is to be submitted for the purchase of Baseball and Softball Equipment (or equivalents) as listed in the bid specifications.

The Town Board reserves the right to consider informal any bid not prepared and submitted in accordance with the provisions of the specifications and contract documents, and may waive any informalities, make an award to other than the low bidder should it be in the best interest of the Town, or reject any or all bids.

By order of the Town Board of the Town of Cheektowaga, Erie County, New York.

Alice Magierski
Town Clerk

Dated : January 18, 2011

RESULT:	ADOPTED [UNANIMOUS]
MOVER:	Richard Zydell, Councilmember
SECONDER:	James Rogowski, Councilmember
AYES:	Holtz, Jaworowicz, Swiatek, Rogowski, Zydell, Markel, Kaznowski



9. RESOLUTION 2011-48

Approve Memberships in Various Organizations

Sponsored By: Councilmember Zydel, Councilmember Rogowski

WHEREAS, the Town of Cheektowaga Youth & Recreational Services Department needs to maintain memberships in various organizations in order to effectively operate its programs, and

WHEREAS, the Youth & Recreational Services Department currently maintains memberships in the following organization/associations:

- USA Hockey
- , and

WHEREAS, the Youth & Recreational Services Department needs to acquire permits from the Erie County Health Department/Commissioner of Finance for the Town pools and other facilities, NOW, THEREFORE, BE IT

RESOLVED, that this Town Board hereby approves membership/organization/permit fees for the above for the Youth & Recreational Services Department and directs that fees for same be paid out of the appropriate department budget line items.

RESULT:	ADOPTED [UNANIMOUS]
MOVER:	Richard Zydel, Councilmember
SECONDER:	James Rogowski, Councilmember
AYES:	Holtz, Jaworowicz, Swiatek, Rogowski, Zydel, Markel, Kaznowski



10. RESOLUTION 2011-49

Negative Declaration - North Creek Drive Sanitary Sewer Interceptor

Sponsored By: Councilmember Kaznowski, Councilmember Rogowski

WHEREAS, pursuant to the Environmental Impact Review Ordinance of the Town of Cheektowaga, the Environmental Advisory Committee ("EAC") reviews various applications for site plans, rezonings, special permits, etc. and renders its recommendation concerning the environmental significance of such application, AND

WHEREAS, the Town Board, pursuant to the Environmental Impact Review Ordinance of the Town of Cheektowaga, is designated the Lead Agency in most instances, AND

WHEREAS, since the Town Board is the Lead Agency, it must affirm, modify or reject any recommendations submitted to it by the Advisory Committee, AND

WHEREAS, an application was submitted by the Town of Cheektowaga Engineering Department for the construction of 5,028 lineal feet of 21 inch sanitary sewer along the southern edge of North Creek Drive to relieve sewer surcharging, AND

WHEREAS, the Environmental Advisory Committee at its meetings held on January 12, 2011 recommended a determination of non-significance, AND

WHEREAS, this Town Board has reviewed the application submitted and the recommendations made by the Environmental Advisory Committee, NOW, THEREFORE, BE IT

RESOLVED, that this Town Board determines that the project will not have a significant effect on the environment and therefore issues a Negative Declaration for purposes of SEQRA.

RESULT:	ADOPTED [UNANIMOUS]
MOVER:	Stanley Kaznowski, Councilmember
SECONDER:	James Rogowski, Councilmember
AYES:	Holtz, Jaworowicz, Swiatek, Rogowski, Zydel, Markel, Kaznowski



11. RESOLUTION 2011-50

Establish Part-Time Employees Wage Rates

Sponsored By: Supervisor Holtz, Councilmember Jaworowicz

BE IT RESOLVED, that the following PART-TIME EMPLOYEES wage rates be established effective 1/3/2011:

DOG CONTROL

Assistant Dog Control Officer \$10.25

Amanda Burgett

Sandra Kobee

CENTRAL GARAGE

Clerk Part-time \$10.00

Jovina Pagano

RECORDS CENTER

Clerk Part-time \$8.50

Sandra Fetter

BUILDING & PLUMBING

Clerk Part-time \$8.25

Genevieve Fronczak

BUILDING MAINTENANCE

Laborer Part-time \$9.00

Cynthia Schaefer

Laborer Part-time \$8.00

John Matecki

Gerald Scheib

Robert Szymkowiak

FACILITIES/PARKS

Laborer Part-time \$8.00

James Brundo

Robert Fetter

Aaron Hausberger

Nicholas Herkey

Dennis McDonald

Christopher O'Neill

Brian Rogowski

SENIOR SERVICES

Recreation Instructor - Part-time \$10.00

Debra Geary

SEWER MAINTENANCE

Laborer Part-time \$8.00

Frank Latchford

MAIN PUMP STATION

Clerk Part-time \$10.00

Sheryl Klaffka

SANITATION DEPARTMENT

Clerk Part-time \$8.75

Sharon Kotrys

RESULT:	ADOPTED [UNANIMOUS]
MOVER:	Mary Holtz, Supervisor
SECONDER:	Patricia Jaworowicz, Councilmember
AYES:	Holtz, Jaworowicz, Swiatek, Rogowski, Zydel, Markel, Kaznowski



12. RESOLUTION 2011-51

Youth & Recreation Transfers

Sponsored By: Councilmember Zydel, Councilmember Rogowski

BE IT RESOLVED that the individuals listed below be and hereby are hired and/or transferred, as indicated, in the Department of Youth & Recreational Services, effective immediately:

Recreation Aide - 7140.1630 - \$7.25 - Part-time
 MiKayla Bluff-Pierce 14225
 Gabrielle Padovani 14225

BE IT FURTHER RESOLVED that the individuals listed below whose titles/salaries were incorrectly listed be corrected as follows:

Recreation Aide - 7140.1630 - \$7.50- Part-time (Effective 1/3/11)
 Jessica Arana
 Holly Gasielki

Recreation Aide to Recreation Attendant - 7140.1614 - \$7.60 - Regular Part-time
 Matthew Koszuta

Motion by Supervisor Holtz; Seconded by Councilmember Rogowski to waive the reading of names for the following three (3) resolutions: 2011-51; 2011-52 and 2011-53. Motion Carried

RESULT: ADOPTED [UNANIMOUS]
MOVER: Richard Zydel, Councilmember
SECONDER: James Rogowski, Councilmember
AYES: Holtz, Jaworowicz, Swiatek, Rogowski, Zydel, Markel, Kaznowski



13. RESOLUTION 2011-52

Youth & Recreation Terminations

Sponsored By: Councilmember Zydel, Councilmember Rogowski

BE IT RESOLVED that the individuals listed below be and hereby are terminated in the Department of Youth & Recreational Services, effective as indicated:

Greg McEvoy	10/19/10	14225
David Miesowicz	9/30/10	14043

RESULT:	ADOPTED [UNANIMOUS]
MOVER:	Richard Zydel, Councilmember
SECONDER:	James Rogowski, Councilmember
AYES:	Holtz, Jaworowicz, Swiatek, Rogowski, Zydel, Markel, Kaznowski



14. RESOLUTION 2011-53

Hiring/Termination of Part-Time/Seasonal Employees

Sponsored By: Councilmember Swiatek, Supervisor Holtz

BE IT RESOLVED, that the following individuals be and hereby are hired as **PART-TIME EMPLOYEES** in the departments listed, not to exceed nineteen (19) hours on a weekly basis, in compliance with Civil Service Laws and Regulations as well as the provisions of the Town's collective bargaining agreement between the Town of Cheektowaga and the Town of Cheektowaga Employees Association:

SANITATION DEPARTMENT Laborer \$8/hour effective 1/03/11
Michael C. McGill, Cheektowaga, New York

SENIOR SERVICES Van Driver \$8.75/hour effective 1/19/11
Jill M. Wierzba, Sloan, New York

BE IT RESOLVED, that the following seasonal and/or part-time employees be and hereby are terminated as listed:

POLICE DEPARTMENT
Edward G. Hulton, Jr. effective 12/30/10
John W. Reimer effective 11/9/10
Donna G. Chrzanowski effective 12/22/10

SANITATION DEPARTMENT
Michael C. McGill effective 1/01/11
Thomas M. Buil effective 1/01/11
Scott R. Daboin effective 1/01/11

RESULT:	ADOPTED [UNANIMOUS]
MOVER:	Jeff Swiatek, Councilmember
SECONDER:	Mary Holtz, Supervisor
AYES:	Holtz, Jaworowicz, Swiatek, Rogowski, Zydel, Markel, Kaznowski



15. RESOLUTION 2011-54

Appointment of Court Clerk (Competitive/Temporary) Justice Court/Kimberly K. Kent-Chojnicki

Sponsored By: Councilmember Jaworowicz, Councilmember Swiatek

WHEREAS, a temporary vacancy exists in the position of Court Clerk in the Justice Court; AND

WHEREAS, notice of such vacancy has been posted in accordance with the provisions of the Town's collective bargaining agreement with the Town of Cheektowaga Employees Association; AND

WHEREAS, said job title is in the competitive class of civil service; AND

WHEREAS, a valid civil service list is in existence for said title; AND

WHEREAS, Kimberly K. Kent-Chojnicki, currently employed as a part-time Court Officer, has been canvassed for said vacancy and meets all the necessary qualifications for appointment; NOW, THEREFORE, BE IT

RESOLVED, that Kimberly K. Kent-Chojnicki of Cheektowaga, New York be and hereby is appointed to the temporary position of Court Clerk in the Justice Court in accordance with the terms and conditions of the Town's collective bargaining agreement with the Town of Cheektowaga Employees Association, effective January 25, 2011.

RESULT:	ADOPTED [UNANIMOUS]
MOVER:	Patricia Jaworowicz, Councilmember
SECONDER:	Jeff Swiatek, Councilmember
AYES:	Holtz, Jaworowicz, Swiatek, Rogowski, Zydel, Markel, Kaznowski



16. RESOLUTION 2011-55

Appointment of Clerk (Temporary) Facilities Department/Joan C. Meyers

Sponsored By: Councilmember Swiatek, Supervisor Holtz

WHEREAS, a temporary vacancy exists in the position of Clerk in the Facilities Department; AND

WHEREAS, said vacancy is for no more than thirty (30) days; AND

WHEREAS, there is an immediate need to fill said vacancy; AND

WHEREAS, Joan C. Meyers, currently a part-time Clerk in the Facilities Department, meets the necessary qualifications for appointment; NOW, THEREFORE, BE IT

RESOLVED, that Joan C. Meyers of Cheektowaga, New York, be and hereby is appointed to the temporary position of Clerk in the Facilities Department in accordance with the terms and conditions of the Town's collective bargaining agreement with the Town of Cheektowaga Employees Association effective January 5 through January 28, 2011.

RESULT:	ADOPTED [UNANIMOUS]
MOVER:	Jeff Swiatek, Councilmember
SECONDER:	Mary Holtz, Supervisor
AYES:	Holtz, Jaworowicz, Swiatek, Rogowski, Zydel, Markel, Kaznowski

**17. RESOLUTION 2011-56****Appointment of Motor Equipment Operator-A (Non-Competitive/Permanent) Sewer Maintenance Department/Joseph F. Cartenuto**

Sponsored By: Councilmember Swiatek, Supervisor Holtz

WHEREAS, a vacancy exists in the title of Motor Equipment Operator - A in the Sewer Maintenance Department; AND

WHEREAS, the Sewer Maintenance Department was canvassed internally in accordance with an agreement with the Town of Cheektowaga Employees Association; AND

WHEREAS, Joseph F. Cartenuto, currently employed as a Senior Sewer Maintenance Worker in the Sewer Maintenance Department bid on said vacancy and meets all the necessary qualifications for appointment; NOW, THEREFORE, BE IT

RESOLVED, that Joseph F. Cartenuto of Cheektowaga, New York, be and hereby is appointed to the position of Motor Equipment Operator - A in the Sewer Maintenance Department in accordance with the terms and conditions of the Town's collective bargaining agreement with the Town of Cheektowaga Employees Association effective January 19, 2011.

RESULT:	ADOPTED [UNANIMOUS]
MOVER:	Jeff Swiatek, Councilmember
SECONDER:	Mary Holtz, Supervisor
AYES:	Holtz, Jaworowicz, Swiatek, Rogowski, Zydel, Markel, Kaznowski



18. RESOLUTION 2011-57

Travel Authorization (Police Department)

Sponsored By: Councilmember Jaworowicz, Councilmember Swiatek

WHEREAS, the Homicide Investigations Training is being presented by SRR Training from February 7 through February 9, 2011 in East Hartford, Connecticut; AND

WHEREAS, Police Lieutenant Thomas Wentland has requested authorization to attend said training; AND

WHEREAS, Police Chief Christine Ziemba has submitted a request for travel authorization along with the proper paperwork in a timely manner; AND

WHEREAS, the total cost to the Town shall not exceed \$900; AND

WHEREAS, these expenses have been budgeted by the Police Department; NOW, THEREFORE, BE IT

RESOLVED, that Police Lieutenant Thomas Wentland be and hereby is authorized to attend the Homicide Investigations Training being presented by SRR Training from February 7 through February 9, 2011 in East Hartford, Connecticut.

RESULT:	ADOPTED [UNANIMOUS]
MOVER:	Patricia Jaworowicz, Councilmember
SECONDER:	Jeff Swiatek, Councilmember
AYES:	Holtz, Jaworowicz, Swiatek, Rogowski, Zydel, Markel, Kaznowski



19. RESOLUTION 2011-58

Travel Authorization (Emergency Services)

Sponsored By: Councilmember Swiatek, Supervisor Holtz

WHEREAS, the New York State Emergency Management Winter Conference is being held February 8 through February 10, 2011 in Syracuse, New York; AND

WHEREAS, Natural Disaster Coordinator Earl Loder has requested authorization to attend said conference; AND

WHEREAS, Mr. Loder has submitted a request for travel authorization along with the proper paperwork in a timely manner; AND

WHEREAS, the total cost to the Town shall not exceed \$350; AND

WHEREAS, these expenses have been budgeted; NOW, THEREFORE, BE IT

RESOLVED, that Natural Disaster Coordinator Earl Loder be and hereby is authorized to attend the New York State Emergency Management Winter Conference being held February 8 through February 10, 2011 in Syracuse, New York.

RESULT:	ADOPTED [UNANIMOUS]
MOVER:	Jeff Swiatek, Councilmember
SECONDER:	Mary Holtz, Supervisor
AYES:	Holtz, Jaworowicz, Swiatek, Rogowski, Zydel, Markel, Kaznowski

V. Suspension of Rules

Motion by Councilmember Rogowski ; Seconded by Supervisor Holtz to Suspend the Rules to Include the Following Two (2) Resolutions: 2011-59 and 2011-60. Motion Carried.



1. RESOLUTION 2011-59

Issue Negative Declaration -- 2185 Walden Avenue - Derrick Corporation

Sponsored By: Markel, Kaznowski, Holtz, Rogowski, Zydel, Swiatek, Jaworowicz

WHEREAS, pursuant to the Environmental Impact Review Ordinance of the Town of Cheektowaga, the Environmental Advisory Committee ("EAC") reviews various applications for site plans, rezonings, special permits, etc. and renders its recommendation concerning the environmental significance of such application, AND

WHEREAS, the Town Board, pursuant to the Environmental Impact Review Ordinance of the Town of Cheektowaga, is designated the Lead Agency in most instances, AND

WHEREAS, since the Town Board is the Lead Agency, it must affirm, modify or reject any recommendations submitted to it by the Advisory Committee, AND

WHEREAS, an application was submitted by Derrick Corporation for the rezoning of 2185 Walden Avenue from MS- Motor Service to M1- Light Manufacturing for the construction of a 123,555 square foot manufacturing addition to the Derrick Corporation at 590 Duke road, AND

WHEREAS, the Environmental Advisory Committee at its meetings held on January 12, 2011 reviewed the subject project and subsequent to said meeting later recommended a determination of non-significance, AND

WHEREAS, the Town of Cheektowaga Planning Board recommended approval of the rezoning request and the site plan at their meetings of December 9, 2010 and January 13, 2011, respectively, AND

WHEREAS, the Town of Cheektowaga Traffic Safety Commission has reviewed the subject project and is recommending pedestrian walks be installed along Duke Road, as needed, AND

WHEREAS, this Town Board has reviewed the application submitted and the recommendations made by the Environmental Advisory Committee, the Planning Board and the Traffic Safety Commission, NOW, THEREFORE, BE IT

RESOLVED, that this Town Board determines that the project will not have a significant effect on the environment and therefore issues a Negative Declaration for purposes of SEQRA, AND BE IT

FURTHER RESOLVED, the proposed site plan is found to be acceptable subject to :

1. The Town Engineer reviewing and approving the drainage and grading plan.
2. The Town Board abandoning / modifying existing drainage easements affecting the subject expansion project.
3. The Planning Board finalizing architectural character with the applicant.

RESULT:	ADOPTED [UNANIMOUS]
MOVER:	Charles Markel, Councilmember
SECONDER:	Stanley Kaznowski, Councilmember
AYES:	Holtz, Jaworowicz, Swiatek, Rogowski, Zydel, Markel, Kaznowski



2. RESOLUTION 2011-60

Approve Rezoning of 2185 Walden Avenue

Sponsored By: Markel, Kaznowski, Rogowski, Holtz, Swiatek, Jaworowicz, Zydel

WHEREAS, Derrick Corporation petitioned for a rezoning from MS-Motor Service District to M1-Light Manufacturing District for property owned by it and located at 2185 Walden Avenue, Cheektowaga, New York which property is described in the attached legal description, for the construction of a 123,555 square foot manufacturing addition to Derrick Corporation at 590 Duke Road, and

WHEREAS, a public hearing on such petition was held before this Town Board on the 18th day of January, 2011 at 6:45 P.M., after publication and service of the notices required by the provisions of the Code of the Town of Cheektowaga ("Zoning Law"), and the Town Law; and all interested parties were given an opportunity to be heard at such hearing, and

WHEREAS, the Cheektowaga Planning Board has reviewed such application and has recommended approval thereof, and

WHEREAS, this Town Board previously issued a Negative Declaration under SEQRA and the Town Environmental Impact Review Ordinance for this rezoning, NOW, THEREFORE, BE IT

RESOLVED, that the application of Derrick Corporation for the rezoning from MS-Motor Service District to M1 - Light Manufacturing District for the property described in the attached legal description be and the same is hereby approved subject to the following condition:

1. Any future additions to the site plan must be resubmitted to the Town Board to determine that the addition is substantially in agreement with the intent of this rezoning;
2. Grading and Drainage plan to be approved by the Town Engineer;
3. Town Engineer and Town Board approving the abandonment and/or modification of existing drainage easements

, and BE IT FURTHER

RESOLVED, that the Zoning Map and Law of the Town Of Cheektowaga be amended in accordance with the above.

LEGAL DESCRIPTION

PARCEL A

ALL THAT TRACT OR PARCEL OF LAND, situate in the Town of Cheektowaga, County of Erie and State of New York, being part of Lot No. 16, Township 11, Range 7 of the Holland Land Company's Survey, bounded as follows:

BEGINNING in the northwesterly line of Duke Road at the most southerly corner of lands described in a memorandum of lease to Sun Oil Company recorded in Erie County Clerk's Office in Liber 5816 of Deeds, at Page 13; running thence south 30°-27' west along said

northwesterly line of Duke Road 31.18 feet to an angle in said line; thence continuing southwesterly along the northwesterly line of Duke Road 787.34 feet to the east line of lands conveyed to Lawrence Walsh by deed recorded in Erie County Clerk's Office in Liber 255 of Deeds, at Page 112; thence northerly along said east line 707.44 feet to the north line of lands conveyed to Elijah Efner by deed recorded in Erie County Clerk's Office in Liber 232 of Deeds at Page 634; thence easterly along said north line 552.42 feet to the west line of lands leased to Sun Oil Company as described in memorandum of lease aforesaid; thence southerly along said west line of 94 feet to an angle in said line; and thence southeasterly still along lands so described 131 feet to the point of beginning.

EXCEPT THEREFROM ALL THAT TRACT OR PARCEL OF LAND situate in the Town of Cheektowaga, County of Erie and State of New York being part of Lot No. 16, Township 11, Range 7 of the Holland Land Company's survey, described as follows: Beginning in the north line of Duke Road (66 feet wide), at its intersection with the east line of lands of Lawrence Walsh described in deed recorded in Liber 255 of Deed page 112; thence northeasterly along said east line of the lands of Walsh, for a distance of 707.44 feet to the north line of lands of Elijah Efner described in deed recorded in Liber 232 of Deeds page 634; thence easterly along said north line of the lands of Elijah Efner, for a distance of 125.01 feet to a point on said north line, which is located 577.41 feet westerly of the east line of Lot No. 16; thence southwesterly at an interior angle with the last described line of 89°-20'-58", for a distance of 610.79 feet to a point on said north line of Duke Road, distant 159.46 feet easterly of the intersection of said north line of Duke Road with said east line of the lands of Walsh as described in deed recorded in the Erie County Clerk's Office in Liber 255 of Deeds page 112; thence southwesterly along said north line of Duke Road, for a distance of 159.46 feet to the point or place of beginning.

PARCEL B

ALL THAT CERTAIN PLOT, PIECE OR PARCEL OF LAND, situate, lying and being in the Town of Cheektowaga, County of Erie, State of New York being part of Lot number 16, Township 11, Range 7 of the Holland Land Company's Survey more particularly bounded and described as follows:

BEGINNING at the most easterly point of lands conveyed to Carlton W. Hasselback by deed recorded in the Erie County Clerk's Office in Liber 5956 of Deeds page 398, said point of beginning also being 82.54 feet westerly from the east line of Liber 6694 of Deeds page 273, as measured along the southerly highway boundary line of Walden Avenue.

RUNNING THENCE westerly along the southerly line of such land in said Liber 5956 of Deeds page 398 a distance of 289.80 feet to a point;

RUNNING THENCE northerly at right angles, a distance of 66.97 feet, (said line being 80.05 feet easterly from the southeasterly corner of the car wash structure now situated on the premises immediately adjoining on the west) to a point on the southerly highway boundary line of Walden Avenue;

RUNNING THENCE southeasterly at an interior angle of 76 degrees 59'-15" and along the said southerly line of Walden Avenue, 297.43 feet to the POINT or PLACE of BEGINNING.

Being the same premises described in the deed dated 6/7/68 recorded 6/7/68 in Liber 7475 Page 417.

RESULT:	ADOPTED [UNANIMOUS]
----------------	----------------------------

MOVER:	Charles Markel, Councilmember
SECONDER:	Stanley Kaznowski, Councilmember
AYES:	Holtz, Jaworowicz, Swiatek, Rogowski, Zydel, Markel, Kaznowski

VI. Communications

A. Departmental Communications

1. Supervisor's Statement of Funds - November 2010
2. Quarterly Report for October to December 2010 from Town of Cheektowaga Emergency Services
3. Minutes: Town Environmental Advisory Committee - August 25, 2010
4. Minutes: Town Environmental Advisory Committee - December 14, 2010
5. Minutes: Cheektowaga Planning Board - December 9, 2010
6. Minutes: Cheektowaga Public Library - Board of Trustees - December 15, 2010

B. General Communications

1. Designation of Restricted Highway: New York State Department of Transportation: Beginning on Route 33 Westbound at a Point 1000 Feet East of the Route 277 (Union Road) Overpass and Continuing Westerly for a Distance of Approximately 3000 Feet to the Beach Road Underpass. All in the Town of Cheektowaga, Erie County
2. Summons: Citimortgage, Inc. Vs. Shannon M. Spencer, the Town of Cheketowaga & Etal Premises 130 Ridge Park Avenue
3. Notice of Claim: Derrick Anderson Vs. Town of Cheektowaga
4. Notice of Claim: Teresa Bova Vs. Town of Cheektowaga
5. Notice of Claim: John C. Conaway Vs. Town of Cheektowaga
6. Notice of Claim: Arthur Kurzel Vs. Town of Cheektowaga
7. Notice of Claim: Kimberly Loncz Vs. Town of Cheektowaga
8. Notice of Claim: John A. Riford Vs. Town of Cheektowaga
9. Notice of Claim: Marcy Wroblewski Vs. Town of Cheektowaga

VII. Comments

A. Supervisor's Comments

B. Councilmember's Comments

C. Public Comments

VIII. Adjournment

Motion by Supervisor Holtz; Seconded by Councilmember Rogowski to adjourn the meeting.
Time of adjournment was 7:30 PM

Alice Magierski

Town Clerk



Town of Cheektowaga

Work Session

~ Minutes ~

3301 Broadway
Cheektowaga, NY 14227
<http://www.town.cheektowaga.ny.us>

Alice Magierski
716-686-3400

Tuesday, February, 1, 2011

6:00 PM

Council Office

I. Call to Order

6:00 PM Meeting called to order on February 1, 2011 at Council Office, Conference Room, Cheektowaga, NY.

Attendee Name	Organization	Title	Status	Arrived
Mary Holtz	Town of Cheektowaga	Supervisor	Present	
Patricia Jaworowicz	Town of Cheektowaga	Councilmember	Present	
Jeff Swiatek	Town of Cheektowaga	Councilmember	Present	
James Rogowski	Town of Cheektowaga	Councilmember	Absent	
Richard Zydel	Town of Cheektowaga	Councilmember	Present	
Charles Markel	Town of Cheektowaga	Councilmember	Present	
Stanley Kaznowski	Town of Cheektowaga	Councilmember	Present	

2. Additional Attendees

Brian Krause, Director of Finance and Administration
Kevin Schenk, Town Attorney
Christine Ziemba, Chief of Police
Michael Hughes

3. Motion To: Enter Into Executive Session

RESULT: ADOPTED [UNANIMOUS]
MOVER: Mary Holtz, Supervisor
SECONDER: Stanley Kaznowski, Councilmember
AYES: Holtz, Jaworowicz, Swiatek, Zydel, Markel, Kaznowski
ABSENT: James Rogowski

4. Motion To: Exit Executive Session and return to Work Session

RESULT: ADOPTED [UNANIMOUS]
MOVER: Mary Holtz, Supervisor
SECONDER: Richard Zydel, Councilmember
AYES: Holtz, Jaworowicz, Swiatek, Zydel, Markel, Kaznowski
ABSENT: James Rogowski

II. Resolutions



1. RESOLUTION 2011-61

Settlement of Litigation - Properties Unlimited V Town

Sponsored By: Supervisor Holtz, Councilmember Zydel

WHEREAS, Properties Unlimited, a/k/a GHC, LLC commenced an Article 7 proceeding against the Town for Tax Year 2007-2008 seeking a reduction in the assessment of 62 various properties owned by it located in the Cedargrove Heights area in Cheektowaga, New York; and

WHEREAS, the Town's outside Attorney consultant and the Town Assessor have reviewed the petitions and, after due consideration of all materials facts, and after negotiations with the petitioner's attorney, believe it is in the best interest of the Town to resolve this matter without further litigation and strongly recommend the proposed compromise; NOW THEREFORE, BE IT

RESOLVED, that the Town Board approves the above compromise and settlement, and the Town's outside Attorney consultant and Town Assessor be and hereby are authorized to execute and procure all papers necessary to effectuate the settlement of said Article 7 proceedings.

RESULT:	ADOPTED [UNANIMOUS]
MOVER:	Mary Holtz, Supervisor
SECONDER:	Richard Zydel, Councilmember
AYES:	Holtz, Jaworowicz, Swiatek, Zydel, Markel, Kaznowski
ABSENT:	James Rogowski



2. RESOLUTION 2011-62

Authorize Supervisor to File Application for 2011-2012 Tree Planting Program

Sponsored By: Councilmember Jaworowicz, Supervisor Holtz

BE IT RESOLVED, that Mary F. Holtz as Supervisor of the Town of Cheektowaga, or such person's successor, is hereby authorized and directed to file an application for 50% matching funds in an amount not to exceed \$25,000, and upon approval of said request to enter into and execute a project agreement with the New York State Department of Environmental Conservation for such financial assistance to the Town of Cheektowaga for the Town of Cheektowaga 2011 - 2012 Tree Planting Program.

RESULT:	ADOPTED [UNANIMOUS]
MOVER:	Patricia Jaworowicz, Councilmember
SECONDER:	Mary Holtz, Supervisor
AYES:	Holtz, Jaworowicz, Swiatek, Zydel, Markel, Kaznowski
ABSENT:	James Rogowski



Town of Cheektowaga

Regular Meeting

~ Minutes ~

3301 Broadway
Cheektowaga, NY 14227
<http://www.town.cheektowaga.ny.us>

Alice Magierski
716-686-3400

Monday, February 7, 2011

6:45 PM

Council Chambers

I. Call to Order

6:45 PM Meeting called to order on February 7, 2011 at Council Chambers, 3301 Broadway St, Cheektowaga, NY.

Attendee Name	Organization	Title	Status	Arrived
Mary Holtz	Town of Cheektowaga	Supervisor	Present	
Patricia Jaworowicz	Town of Cheektowaga	Councilmember	Present	
Jeff Swiatek	Town of Cheektowaga	Councilmember	Present	
James Rogowski	Town of Cheektowaga	Councilmember	Present	
Richard Zydel	Town of Cheektowaga	Councilmember	Present	
Charles Markel	Town of Cheektowaga	Councilmember	Present	
Stanley Kaznowski	Town of Cheektowaga	Councilmember	Present	

2. Additional Attendees

Thomas Adamczak, Supervising Building and Plumbing Inspector
Jerry Gabryszak, Director of Community Development
Brian Krause, Director of Finance and Administration
John Marriott, Planning Board Chairman
William Pugh, Town Engineer
Kevin Schenk, Town Attorney
Christine Ziemba, Chief of Police

II. Public Comment Period

III. Public Hearings

1. Demolition of 24E Glenwood Court

This being the time and place advertised for a Public Hearing, the Supervisor directed the Town Clerk to present that such notice has been duly published and posted; upon the order of the Supervisor such proof was duly filed.

The Supervisor announced that the Town Board would hear all persons interested in the subject of the hearing. Comments were heard, after which the Supervisor declared the hearing closed, decision was reserved.

RESULT: CLOSED [UNANIMOUS]
MOVER: James Rogowski, Councilmember
SECONDER: Charles Markel, Councilmember
AYES: Holtz, Jaworowicz, Swiatek, Rogowski, Zydel, Markel, Kaznowski

2. Demolition of 89 Gardenvale Drive

This being the time and place advertised for a Public Hearing, the Supervisor directed the Town Clerk to present that such notice has been duly published and posted; upon the order of the Supervisor such proof was duly filed.

The Supervisor announced that the Town Board would hear all persons interested in the subject of the hearing. Comments were heard, after which the Supervisor declared the hearing closed, decision was reserved.

RESULT: CLOSED [UNANIMOUS]

MOVER: James Rogowski, Councilmember

SECONDER: Charles Markel, Councilmember

AYES: Holtz, Jaworowicz, Swiatek, Rogowski, Zydel, Markel, Kaznowski

3. Demolition of 27 Alpine Place

This being the time and place advertised for a Public Hearing, the Supervisor directed the Town Clerk to present that such notice has been duly published and posted; upon the order of the Supervisor such proof was duly filed.

The Supervisor announced that the Town Board would hear all persons interested in the subject of the hearing. Comments were heard, after which the Supervisor declared the hearing closed, decision was reserved.

RESULT: CLOSED [UNANIMOUS]

MOVER: James Rogowski, Councilmember

SECONDER: Charles Markel, Councilmember

AYES: Holtz, Jaworowicz, Swiatek, Rogowski, Zydel, Markel, Kaznowski

IV. Resolutions



1. RESOLUTION 2011-63

Transfer of Funds - 2010

Sponsored By: Supervisor Holtz, Councilmember Swiatek

BE IT RESOLVED, that the following transfer is hereby approved and made a part hereof;

2010

GENERAL FUND

FROM:	100.1910.3088	Misc. State Aid	\$ 1,610.04
	100.1315.4001	Office Supplies	728.00
	100.1355.4082	Travel, Training	522.00
	100.1410.4111	Publishing Notices	258.00
	100.1420.4088	Travel, Training	1,140.00
	100.1430.4011	Printing Contracts	1,140.00
	100.1420.4501	Contracted Legal	17,704.00
	100.9010.8141	Medical Insurance	12,689.00
	100.1430.4093	Town Training	1,500.00
	100.1625.4217	Utilities	414.00
	100.1640.4442	Equipment Repair	2,837.00
	100.1640.4446	Maint & Repair Motor Equip	1,407.00
	100.1640.2502	Pool Cars	2,068.00
	100.9010.8141	Medical Insurance	94,312.00
	100.1680.4434	Software Maintenance	15,531.00
	100.1680.4437	Pooled Maintenance Costs	10,407.00
	100.1910.4706	Real Property Taxes	13,992.00
	100.1910.4711	Contingency	20,138.00
	100.5132.4211	Electricity Highway	833.00
	100.7140.4191	Misc Expense	1,345.00
	100.7310.4431	Equipment Repairs	52.00
	100.7310.4261	Postage	17.00
	100.6410.4195	Events	737.00
TO:	100.1220.4010.0002	Disaster Preparedness	\$ 1,610.04
	100.1315.4011	Printed Forms	240.00
	100.1315.4431	Maintenance Agreement	488.00
	100.1355.4431	Maintenance Agreement	522.00
	100.1410.4188	Equipment Rental	258.00
	100.1420.2201	Office Equipment	180.00
	100.1420.4001	Office Supplies	105.00
	100.1420.4013	Law Books	855.00
	100.1430.2501	Office Equipment	343.00
	100.1430.4502	Legal Personnel	30,393.00
	100.1430.4752	Pre-Employment Physical	2,297.00
	100.1625.4202	Telephone-Townwide	414.00
	100.1640.4441	Equipment Repair-Police	2,837.00
	100.1640.4445	Parks-Equipment Repair	1,407.00
	100.1640.4447	Collision Repairs	2,068.00
	100.1680.2202	Network Hardware	94,312.00

100.1680.2204	Computer Hardware	23,624.00
100.1680.4321	Software Licensing	1,216.00
100.1680.4431	Hardware Maintenance	1,098.00
100.1910.4322	Contracted Services HEAP	34,130.00
100.5132.4432	Repairs & Maintenance	833.00
100.7140.4999	Credit Card Expense	1,345.00
100.7310.4001	Office Supplies	52.00
100.7310.4693	Dev. Disabled	17.00
100.7550.4371	Polish Festival	737.00
<u>SPECIAL DISTRICTS FUND</u>		
FROM: 255.8125.4163	Gas, Oil & Grease	\$ 2,005.00
255.8125.4217	Utilities	33,563.00
TO: 255.8125.2505	Office Equipment	\$ 2,005.00
255.8125.4353	Erie Co. Sewer Dist. 4	33,563.00
<u>HIGHWAY FUND</u>		
FROM: 300.9010.8141	Medical Insurance	\$ 11,632.00
300.5110.4185	Barricades & Block	459.00
300.9501.9131	Bond Principal	140,000.00
300.9501.9211	Bond Interest	48,127.00
TO: 300.5110.4162	Gasoline & Oil	\$ 11,632.00
300.5130.4462	Parts & Supplies	407.00
300.5140.4188	Rental of Copier	52.00
300.5142.4180		188,127.00
<u>PART TOWN FUND</u>		
FROM: 800.3620.4088	Travel & Conferences	\$ 1,418.00
800.3620.4191	Misc. Expense	1,167.00
800.9010.8141	Medical Insurance	20,583.00
800.3620.2770	Permits & Inspections	74,394.00
TO: 800.3620.2201	Office Equipment	\$ 2,641.00
800.3620.4411	Refunds of Permits	74,394.00
800.3620.4561	Contracted Services	2,400.00
800.3620.4411	Refunds of Permits	18,127.00

RESULT:	ADOPTED [UNANIMOUS]
MOVER:	Mary Holtz, Supervisor
SECONDER:	Jeff Swiatek, Councilmember
AYES:	Holtz, Jaworowicz, Swiatek, Rogowski, Zydel, Markel, Kaznowski



2. RESOLUTION 2011-64

Transfer of Funds 2011

Sponsored By: Supervisor Holtz, Councilmember Swiatek

BE IT RESOLVED, that the following transfer is hereby approved and made a part hereof;

2011

GENERAL FUND

FROM:	100.1415.3500	State Aid Archive	\$ 11,717.00
TO:	100.1415.4001	Contractual Services	\$ 11,717.00

SPECIAL DISTRICTS FUND

FROM:	990.1910.2681	Light Standard Damages	\$ 6,461.89
TO:	990.5182.4432	Repairs & Maintenance	\$ 6,461.89

HUD CDBG FUND

FROM:	700.1010.0601	Multi Family Rehab	\$ 30,000.00
	700.1010.0600	Single Family Rehab	60,000.00
	700.1010.0600	Single Family Rehab	10,000.00
TO:	700.1010.0602	Demolition	\$ 30,000.00
	700.1010.0602	Demolition	60,000.00
	700.1010.0606	Disposition	10,000.00

RESULT:	ADOPTED [UNANIMOUS]
MOVER:	Mary Holtz, Supervisor
SECONDER:	Jeff Swiatek, Councilmember
AYES:	Holtz, Jaworowicz, Swiatek, Rogowski, Zydel, Markel, Kaznowski



3. RESOLUTION 2011-65

Warrant

Sponsored By: Supervisor Holtz, Councilmember Swiatek

BE IT RESOLVED, that the following Vouchers & Warrants submitted to the Town of Cheektowaga prior to February 4, 2011 are hereby approved and made a part hereof;

GENERAL FUND	\$ 1,012,782.97
RISK RETENTION FUND	126,715.79
HUD HOUSING REHABILITATION FUND	25,013.00
SPECIAL DISTRICTS FUND	444,695.53
HIGHWAY FUND	356,441.95
CAPITAL FUND	268,138.55
TRUST & AGENCY FUND	6,711,282.19
HUD CDBG FUND	42,869.76
PART TOWN FUND	37,450.32
NYS AFFORDABLE HOUSING	6,991.00
	<u>\$ 9,032,381.06</u>

RESULT: **ADOPTED [UNANIMOUS]**

MOVER: Mary Holtz, Supervisor

SECONDER: Jeff Swiatek, Councilmember

AYES: Holtz, Jaworowicz, Swiatek, Rogowski, Zydel, Markel, Kaznowski



4. RESOLUTION 2011-66

Award of Bid - ONE (1) NEW AND UNUSED 2011 FORD F250 SUPER DUTY 4X4 CREW CAB WITH a 6 3/4' BOX OR EQUAL

Sponsored By: Councilmember Swiatek, Supervisor Holtz

WHEREAS, bids were received and opened by the Town Clerk at a public bid opening held on January 19, 2011, for One (1) New and Unused, 2011 Ford F250 Super Duty 4x4 Crew Cab with a 6 3/4' Box or Equal for use by the Town of Cheektowaga Highway Department as a result of advertisement thereof, and such bid was referred to the Superintendent of Highway for Analysis, tabulation and reports, AND

WHEREAS, bids were analyzed and completed, NOW THEREFORE BE IT

RESOLVED, the responsible bidder meeting bid specs for One (1) New and Unused, 2011 Ford F250 Super Duty 4x4 Crew Cab with a 6 3/4' Box or Equal be awarded to Delacy Ford, Inc., 3061 Transit Road, Elma, NY 14059 at a total bid price of \$20,696.00 said bidder meeting specifications of bid. AND, BE IT FURTHER

RESOLVED, that monies be charged to line item 300-5130-2407.

TABULATION FOR ONE (1) NEW AND UNUSED 2011 FORD F250 SUPER DUTY 4X4 CREW CAB WITH A 6 3/4' BOX OR EQUAL

Delacy Ford, Inc.	\$32,296.00 - 2011 Ford F250
3061 Transit Road	- <u>\$11,600.00</u> - Trade-In Allowance
Elma, NY 14059	\$20,696.00 - Total Price

Basil Ford Inc.	\$32,777.00 - 2011 Ford F250
1540 Walden Ave.	- <u>\$10,000.00</u> - Trade-In Allowance
Cheektowaga, NY 14225	\$22,777.00 - Total Price

West Herr Ford	\$34,242.00 - 2011 Ford F250
5025 Camp Road	- <u>\$10,000.00</u> - Trade-In Allowance
Hamburg, NY 14075	\$24,242.00 - Total Price

RESULT:	ADOPTED [UNANIMOUS]
MOVER:	Jeff Swiatek, Councilmember
SECONDER:	Mary Holtz, Supervisor
AYES:	Holtz, Jaworowicz, Swiatek, Rogowski, Zydel, Markel, Kaznowski



5. RESOLUTION 2011-67

Call for Public Hearing to Amend Parks Ordinance

Sponsored By: Councilmember Rogowski, Councilmember Kaznowski

WHEREAS, the Town of Cheektowaga previously adopted a Parks Ordinance (Chapter 174 of the Code of the Town of Cheektowaga) with amendments thereto, and Rules and Regulations governing Cheektowaga Town Parks which apply to all public parks and public park approaches owned by the Town of Cheektowaga, and

WHEREAS, the existing Parks Ordinance does not permit dogs in the parks or park approaches, and

WHEREAS, the Town of Cheektowaga would like to permit the walking of dogs on leashes in the various town parks, excluding John C. Stiglmeier Park and Cheektowaga Town Park, subject to certain restrictions, and

WHEREAS, this Town Board desires to amend the Parks Ordinance to permit said activities in this area of our park, NOW, THEREFORE, BE IT

RESOLVED, that, in accordance with the provisions of Section 130 of the Town Law of the State of New York, a public hearing will be held on the 7th day of March, 2011 at 6:45 P.M. at a meeting of the Town Board at the Cheektowaga Town Hall, 3301 Broadway, Cheektowaga, New York 14227, at which hearing all parties in interest and citizens shall have an opportunity to be heard and at which time and place it may be determined by the Town Board whether Chapter 174 of the Code of the Town of Cheektowaga ("Parks Ordinance") shall be amended as provided in the attached Notice of Hearing, and BE IT FURTHER

RESOLVED, that the Town Clerk shall publish the attached Notice of Hearing in the Cheektowaga Bee, the official Town newspaper, not less than ten (10) nor more than twenty (20) days prior to the pubic hearing

NOTICE OF HEARING
ON PROPOSAL TO AMEND
CHAPTER 174 OF THE CODE OF THE TOWN OF CHEEKTOWAGA
("PARKS ORDINANCE")

NOTICE IS HEREBY GIVEN THAT, in pursuance of a resolution of the Town Board of the Town of Cheektowaga, which was duly passed on the 7th day of February, 2011, and in accordance with the provisions of the Town Law of the State of New York, a Public Hearing will be held on the 7th day of March, 2011 at 6:45 P.M. at the Cheektowaga Town Hall, 3301 Broadway, Cheektowaga, New York; at such hearing, all parties in interest and citizens shall have an opportunity to be heard and, at which time and place, it may be determined by the Town Board whether Chapter 174 of the Code of the Town of Cheektowaga ("Parks Ordinance") should be amended and changed as follows:

Section 174-8 of the Parks Ordinance shall be amended to permit dogs in town parks,

excluding John C. Stiglmeier Park and Cheektowaga Town Park, subject to certain enumerated conditions.

A copy of the entire text of the proposed amendments to the Parks Ordinance is on file in the Town Clerk's Office where the same may be viewed during regular business hours.

BY ORDER OF THE TOWN BOARD OF THE TOWN OF CHEEKTOWAGA, ERIE COUNTY, NEW YORK.

Dated; February 7, 2011

Alice Magierski
Town Clerk

ATTACHMENTS:

Proposed Amendment to Parks Ord re dogs in parks (RTF)

RESULT: ADOPTED [UNANIMOUS]
MOVER: James Rogowski, Councilmember
SECONDER: Stanley Kaznowski, Councilmember
AYES: Holtz, Jaworowicz, Swiatek, Rogowski, Zydel, Markel, Kaznowski



6. RESOLUTION 2011-68

Notice to Bidders - Six (6) Police Patrol Vehicles

Sponsored By: Councilmember Jaworowicz, Councilmember Rogowski

BE IT RESOLVED, that the Town Clerk is hereby directed to publish a Notice to Bidders for the Purchase of Six (6) New and Unused 2011 Police Patrol Vehicles by the Town of Cheektowaga Police Department, said notice to be published in the Cheektowaga Bee; and it is further

RESOLVED, that sealed bids will be received by the Town Clerk on the 23rd day of February, 2011 at 11:00 A.M., Eastern Standard Time, at a public bid opening to be held in the Council Chambers in the Cheektowaga Town Hall, 3301 Broadway, Cheektowaga, New York, 14227.

NOTICE TO BIDDERS

Sealed proposals will be received by the Town Clerk of the Town of Cheektowaga on Wednesday, February 23rd, 2011 at 11:00 A.M. at Town Hall, corner of Broadway and Union Roads, for the purchase of six (6) new and unused 2011 police patrol vehicles as specified.

Information for bidders and specifications may be obtained from the Town Clerk at her office in said Town. One bid is to be submitted for the purchase of six (6) new police vehicles as listed in the bid specifications.

The Town Board reserves the right to consider informal any bid not prepared and submitted in accordance with the provisions of the specifications and contract documents, and may waive any informalities, make an award to other than the low bidder, should it be in the best interest of the Town or reject any or all bids.

By order of the Town Board of the Town of Cheektowaga, Erie County, New York.

Alice Magierski
Town Clerk

Dated: February 7, 2011

RESULT:	ADOPTED [UNANIMOUS]
MOVER:	Patricia Jaworowicz, Councilmember
SECONDER:	James Rogowski, Councilmember
AYES:	Holtz, Jaworowicz, Swiatek, Rogowski, Zydel, Markel, Kaznowski



7. RESOLUTION 2011-69

Authorize Town Clerk to Issue New/Renewal Ambulance Drivers/Attendants Licenses

Sponsored By: Councilmember Jaworowicz, Councilmember Zydel

WHEREAS, on the 7th day of May, 1984, this Town Board adopted an Ambulance Ordinance. The EMS Board, which was created at that time, has completed a review and evaluation of new/renewal license applications for driver(s)/attendant(s), and has recommended that the Town Board issue such licenses, NOW, THEREFORE BE IT

RESOLVED, that the recommendations of the EMS Board concerning the licensing of new/renewal driver(s)/attendant(s) shown on the list below be and hereby are accepted and approved, for a period to expire upon the expiration of such ambulance driver(s)/attendant(s) Emergency Medical Technician ('EMT') card and, BE IT FURTHER

RESOLVED, that the Town Clerk be and hereby is authorized, empowered and directed to issue new/renewal licenses to the driver(s)/attendant(s) set forth on the annexed schedule, pursuant to the terms of this resolution.

TOWN OF CHEEKTOWAGA DRIVER/ATTENDANT LICENSE LIST

<u>Name</u>	<u>Expiration Date</u>
Baker, Kevin L , ,	10/31/2013
Ball, Tracey C. , ,	7/31/2013
Curry, Timothy A. , ,	7/31/2013
Gray, Catherine A. , ,	11/30/2013
Guttadauro, Nicholas J. , ,	1/31/2013
Heilig, Kenneth J , ,	3/31/2011
Jackman, Russ II , ,	8/31/2011
Kayani, Harland M , ,	2/29/2012
Lutz, Emily M , ,	3/31/2013
Maclver, Adair M , ,	10/31/2013
Marts, Andrew W , ,	9/30/2012
Mason, Jennifer E , ,	2/28/2013
McGinnis, Eric T , ,	1/31/2013
Miller, Jacob A , ,	10/31/2013
Moleski, Robert M , ,	1/31/2012
Neuman, William M. , ,	9/30/2013

Orlowsk, Jr., Robert R	, ,	12/31/2012
Palumbo, William C	, ,	10/31/2013
Pangallo, John C	, ,	2/28/2013
Redmond, Tracie L	, ,	9/30/2013
Rudyk, John P	, ,	10/31/2013
Ryder, Regina M	, ,	7/31/2013
Simmons, Joseph D	, ,	7/31/2013
Southworth, Bradley S	, ,	2/28/2013
Weishaupt, Lucas W	, ,	6/30/2013
Wellspeak, Dennis R	, ,	11/30/2013
Yohe, Steven C	, ,	10/31/2013
Zepecki, Michael S	, ,	10/31/2013

RESULT: ADOPTED [UNANIMOUS]

MOVER: Patricia Jaworowicz, Councilmember

SECONDER: Richard Zydel, Councilmember

AYES: Holtz, Jaworowicz, Swiatek, Rogowski, Zydel, Markel, Kaznowski



8. RESOLUTION 2011-70

Authorize Supervisor to Execute Agreements with Sponsors of Concerts/Special Events

Sponsored By: Supervisor Holtz, Councilmember Swiatek

WHEREAS, the Senior Services Department and Youth and Recreational Services Department hold various concerts and special events during the year for Town residents and users of Town facilities, and

WHEREAS, by resolution dated November 15, 2010 (Resolution 2010-640), this Town Board authorized the Supervisor to execute contracts for vendors and performers for said concerts/special events for 2011, and

WHEREAS, on occasion, sponsors of these concerts/special events require agreements to be signed, NOW, THEREFORE, BE IT

RESOLVED, that, subject to approval by the Town Attorney, the Supervisor be and hereby is authorized to execute agreements with sponsors of concerts/special events for the Department of Senior Services and the Youth and Recreational Services Department for 2011.

RESULT:	ADOPTED [UNANIMOUS]
MOVER:	Mary Holtz, Supervisor
SECONDER:	Jeff Swiatek, Councilmember
AYES:	Holtz, Jaworowicz, Swiatek, Rogowski, Zydel, Markel, Kaznowski



9. RESOLUTION 2011-71

Authorize Supervisor to Execute Agreements for Nutrition Program for the Elderly for 2011

Sponsored By: Supervisor Holtz, Councilmember Swiatek

WHEREAS, the Town of Cheektowaga operates nutrition programs for the elderly at the following facilities in the Town of Cheektowaga:

Infant of Prague Parish, 921 Cleveland Drive
Cayuga Village Apartments Community Center, 100 Hutchens Drive
Maryvale East Management Corp., 100 Moorman Drive
Bell Tower Senior Apartments, 893 French Road/42 Haley Lane
Southwind Landing Senior Apartments, 5074 Transit Road
Cheektowaga Senior Center, 3349 Broadway

and,

WHEREAS, agreements between the Town of Cheektowaga and the owners of the above facilities have been drafted relative to the continuation of the operation of said nutrition programs for the year 2011, and

WHEREAS, the County of Erie provides financing for such nutrition programs; and an agreement between the Town of Cheektowaga and the County of Erie has been drafted relative to the operation of such nutrition programs for the year 2011, NOW, THEREFORE, BE IT

RESOLVED, that the Supervisor be and hereby is authorized and directed to execute the above referenced agreements on behalf of the Town.

RESULT:	ADOPTED [UNANIMOUS]
MOVER:	Mary Holtz, Supervisor
SECONDER:	Jeff Swiatek, Councilmember
AYES:	Holtz, Jaworowicz, Swiatek, Rogowski, Zydel, Markel, Kaznowski



10. RESOLUTION 2011-72

Authorize Supervisor to Execute Agreement with Erie County for Transportation Services for the Elderly for 2011

Sponsored By: Supervisor Holtz, Councilmember Swiatek

WHEREAS, the Town of Cheektowaga, in concert with the County of Erie, has for years been operating a transportation program for the elderly, utilizing vans, and

WHEREAS, the County of Erie has prepared and submitted to the Town an agreement between the Town of Cheektowaga and the County of Erie relative to the operation of said transportation program for the Year 2011, and

WHEREAS, the Town of Cheektowaga wishes to continue to offer this service to our Town residents, NOW, THEREFORE, BE IT

RESOLVED, that the Supervisor be and hereby is authorized and directed to execute the above referenced agreement on behalf of the Town.

RESULT:	ADOPTED [UNANIMOUS]
MOVER:	Mary Holtz, Supervisor
SECONDER:	Jeff Swiatek, Councilmember
AYES:	Holtz, Jaworowicz, Swiatek, Rogowski, Zydel, Markel, Kaznowski



11. RESOLUTION 2011-73

Authorize Amendment to Agreement with Ice Time of W.N.Y., Inc.

Sponsored By: Councilmember Rogowski, Councilmember Kaznowski

WHEREAS, in 2008, the Town of Cheektowaga entered into an agreement with Ice Time of W.N.Y., Ltd. for the operation of a concession stand and pro shop at the ice rink in the Cheektowaga Recreation Center, and for the installation of vending machines in various Town - owned buildings, and

WHEREAS, fees for said services were established in said agreement, and

WHEREAS, said agreement is set to expire on October 31, 2011

WHEREAS, this Board and the vendor are agreeable to revising the fee schedule, and also wish to extend the term of said agreement until the end of 2012, and

WHEREAS, the Town Attorney has drafted an amendment to the aforementioned agreement, NOW, THEREFORE, BE IT

RESOLVED, that this Town Board hereby approves the aforesaid amendment to the 2008 agreement, and BE IT FURTHER

RESOLVED, that the Supervisor be and hereby is authorized and directed to execute the amendment to the aforementioned lease.

RESULT:	ADOPTED [UNANIMOUS]
MOVER:	James Rogowski, Councilmember
SECONDER:	Stanley Kaznowski, Councilmember
AYES:	Holtz, Jaworowicz, Swiatek, Rogowski, Zydel, Markel, Kaznowski



12. RESOLUTION 2011-74

Accept Creek Maintenance Easement - 1180 French Road

Sponsored By: Councilmember Kaznowski, Councilmember Zydel

WHEREAS, as part of the development of 1180 French Road, the Town of Cheektowaga has requested a creek maintenance easement from the owner of said property to maintain Slate Bottom Creek, and

WHEREAS, the said easement has been signed and submitted to the Town for approval; and

WHEREAS, the Town Engineer and Town Attorney have reviewed this easement and have recommended that the Town accept same, NOW, THEREFORE, BE IT

RESOLVED, that this Town Board hereby accepts the above referenced easement; and BE IT FURTHER

RESOLVED, that the Town Attorney's Office be and hereby is directed to arrange for the filing of such easements in the Erie County Clerk's Office.

RESULT:	ADOPTED [UNANIMOUS]
MOVER:	Stanley Kaznowski, Councilmember
SECONDER:	Richard Zydel, Councilmember
AYES:	Holtz, Jaworowicz, Swiatek, Rogowski, Zydel, Markel, Kaznowski



13. RESOLUTION 2011-75

Approve FY2011 Annual CDBG Action Plan

Sponsored By: Councilmember Markel, Councilmember Kaznowski

WHEREAS, the Town of Cheektowaga is eligible to receive approximately \$1,150,127 in Community Development Block Grant Funds and approximately \$381,508 in HOME Investment Partnership funds for the 2011 program year from the United States Department of Housing & Urban Development, and

WHEREAS, Public hearings regarding the use of said funds were held on November 1, 2010 and January 18, 2011, and

WHEREAS, the Town Director of Community Development has submitted recommendations regarding the use of said funds, which includes activities to principally benefit low-income persons pursuant to the goals and objectives of the Housing and Community Development Act, as amended, and its governing rules and regulations, NOW, THEREFORE, BE IT

RESOLVED, that the Town Board hereby adopts and approves the submission of the Town of Cheektowaga Community Development Block Grant Program Annual Action Plan for 2011 to the Department of Housing and Urban Development for the 2011 Program Year, including the projects contained in the attached CDBG and HOME Project Summaries, and BE IT

FURTHER RESOLVED, that the Supervisor is hereby authorized to sign the required Certifications and any other Community Development Block Grant and HOME Program related documents as may be necessary, including annual grant agreements, with the United States Department of Housing and Urban Development.

**Town of Cheektowaga
Community Development Block Grant Program Budget**

2011 Program Year

Administration	\$ 180,000
Housing Rehabilitation - Single Family Owner-Occupied Units.	260,577
Housing Rehabilitation - Multi-Family Units	40,000
<u>Rehabilitation Activity Delivery Costs</u>	<u>290,000</u>
\$ 230,000 - Inspections	
60,000 - Staff & other program expenses	
Environmental Hazard Testing (Lead Paint, Asbestos & Mold)	15,000
Demolition	4,000
Disposition.	30,000
Acquisition	70,000
Public Safety - Police Foot Patrols	42,000
Housing Counseling Services	8,000
Domestic Violence Program	5,000

Fair Housing	4,000
Weatherization	6,000
Senior Citizen Services Outreach Assistant	8,000
Senior Citizen Program	10,000
Summer Day Camp for Children.....	22,000
<u>Village of Depew</u>	103,860
\$ 41,000 - Public Safety-Police Foot Patrols	
11,000 - Senior Citizen Van Driver	
11,000 - Senior Services Center Support Staff	
40,860 - Sidewalk Replacement	
<u>Village of Sloan</u>	36,690
\$ 10,000 - Demolition of Deteriorated Railroad Building	
\$ 15,000 - Sidewalk Improvements	
\$ 11,690- Drainage and Sewer Improvements	
Contingency B Un-programmed Funds.....	15,000
	CDBG Grant Amount \$ 1,150,127
Projected Revolving Program Income - Housing Rehabilitation	200,000
Projected Revolving Program Income - Economic Development	300,000
TOTAL CDBG BUDGET: Entitlement & Revolving Income Funds	\$ 1,650,127

**Town of Cheektowaga
HOME Investment Partnership Program
2011 Program Year**

HOME Funds*

<u>Acquisition/Rehabilitation - CHDO Project</u>	\$ 180,000
<u>First-Time Homebuyers Program</u>	\$ 40,000
Loans of up to \$7,500 for closing cost/down payment assistance for First-Time Homebuyers.	
<u>Housing Rehabilitation</u>	\$ 151,508
Funds will be used for rehabilitation of owner-occupied housing units in the Town of Cheektowaga.	
<u>Administration and Program Delivery Costs</u>	10,000
	TOTAL B HOME Funds \$ 381,508

* Does not include HOME Program Income, which will be used for HOME eligible activities.

RESULT:	ADOPTED [UNANIMOUS]
MOVER:	Charles Markel, Councilmember
SECONDER:	Stanley Kaznowski, Councilmember
AYES:	Holtz, Jaworowicz, Swiatek, Rogowski, Zydel, Markel, Kaznowski



14. RESOLUTION 2011-76

Youth & Recreation Hiring

Sponsored By: Councilmember Zydel, Councilmember Rogowski

BE IT RESOLVED that the individuals listed below be and hereby are hired and/or transferred, as indicated, in the Department of Youth & Recreational Services, effective immediately:

Recreation Instructor - "Head Lifeguard" - \$9.36 - 7180.1902 - Regular Part-time

Becky Gworek 14227

Lifeguard - Level I - \$8.25 - 7310.1803 - Regular Part-time

Keileigh Pecyne 14227

Recreation Attendant - \$7.40 - 7140.1611 - Regular Part-time

Glen M. Au 14225

Motion by Supervisor Holtz; Seconded by Councilmember Rogowski to Waive the Reading of Names for the Following Two (2) Resolutions: 2011-76 and 2011-77. Motion Carried.

RESULT: ADOPTED [UNANIMOUS]
MOVER: Richard Zydel, Councilmember
SECONDER: James Rogowski, Councilmember
AYES: Holtz, Jaworowicz, Swiatek, Rogowski, Zydel, Markel, Kaznowski



15. RESOLUTION 2011-77

Part-Time/Seasonal Appointments/Terminations

Sponsored By: Councilmember Swiatek, Supervisor Holtz

BE IT RESOLVED, that the following individuals be and hereby are hired as **PART-TIME EMPLOYEES** in the departments listed, not to exceed nineteen (19) hours on a weekly basis, in compliance with Civil Service Laws and Regulations as well as the provisions of the Town's collective bargaining agreement between the Town of Cheektowaga and the Town of Cheektowaga Employees Association:

JUSTICE COURT Court Officer (Competitive/Temporary) \$15.59/hour effective 2/8/11
Shaun R. Turner, Cheektowaga, New York

POLICE DEPARTMENT Substitute School Crossing Guard \$8.50/hour effective 2/1/11
Alan J. Minotti, Cheektowaga, New York

FACILITIES DEPARTMENT (Building and Grounds Division) Laborer \$8.00/hour effective 2/8/11
Timothy J. Dunkowski, Cheektowaga, New York

RESULT:	ADOPTED [UNANIMOUS]
MOVER:	Jeff Swiatek, Councilmember
SECONDER:	Mary Holtz, Supervisor
AYES:	Holtz, Jaworowicz, Swiatek, Rogowski, Zydel, Markel, Kaznowski



16. RESOLUTION 2011-78

Reappointments and Appointments to Cheektowaga Conservation Advisory Committee

Sponsored By: Councilmember Kaznowski, Councilmember Markel

WHEREAS, by resolution dated July 2, 1990, the Cheektowaga Town Board adopted Local Law No. 2 of the Year 1990, entitled "A Local Law to create the Cheektowaga Conservation Advisory Council", and

WHEREAS, pursuant to such law, the Cheektowaga Town Board appointed voting members to such Cheektowaga Conservation Advisory Council ("CCAC"), and

WHEREAS, the terms of such members of the CCAC expired on October 15, 2010, and

WHEREAS, the existing members of the CCAC have expressed an interest in continuing to serve on the CCAC, and

WHEREAS, Patricia Beaman and Robert Becker have expressed an interest in serving on the CCAC, NOW, THEREFORE, BE IT

RESOLVED, that the following individuals be and hereby are re-appointed to the CCAC, effective October 15, 2010 to October 15, 2012:

Frederic Beaman, AIA Architect, Chairman
Lawrence Watson, Member
Lorraine Aloisio, Member
Rosalia Becker, Member
Joseph Fischer, Member

, and BE IT FURTHER

RESOLVED, that Patricia Beaman of Cheektowaga, New York and Robert Becker of Cheektowaga, New York be and hereby are appointed as members of the Cheektowaga Conservation Advisory Council, effective immediately and terminating on October 15, 2012, and BE IT FURTHER

RESOLVED, that the following individuals be and hereby are appointed as ex-officio members of the CCAC, effective from October 15, 2010 to October 15, 2012:

Jane Wiercioch, Member, Zoning Board of Appeals
Daniel Ulatowski, Zoning Inspector
John Marriott, Chairman, Planning Board

RESULT:	ADOPTED [UNANIMOUS]
MOVER:	Stanley Kaznowski, Councilmember
SECONDER:	Charles Markel, Councilmember

AYES: Holtz, Jaworowicz, Swiatek, Rogowski, Zydel, Markel, Kaznowski

**17. RESOLUTION 2011-79**

Appointment of Supervising School Crossing Guard Part-Time (Competitive/Permanent) Police Department/Roberta C. Paul

Sponsored By: Councilmember Jaworowicz, Councilmember Swiatek

WHEREAS, this Town Board appointed Roberta C. Paul to the provisional title of Supervising School Crossing Guard Part-Time in the Police Department effective June 1, 2009; AND

WHEREAS, the Town has been notified that Erie County Civil Service has established a competitive list for said title; AND

WHEREAS, Ms. Paul is eligible for permanent appointment from said list; NOW, THEREFORE, BE IT

RESOLVED, that Roberta C. Paul of Cheektowaga, New York, be and hereby is appointed to the permanent title of Supervising School Crossing Guard Part-Time in the Police Department effective February 8, 2011.

RESULT:	ADOPTED [UNANIMOUS]
MOVER:	Patricia Jaworowicz, Councilmember
SECONDER:	Jeff Swiatek, Councilmember
AYES:	Holtz, Jaworowicz, Swiatek, Rogowski, Zydel, Markel, Kaznowski

**18. RESOLUTION 2011-80****Amendment of Appointment of Clerk to Clerk Typist
(Temporary) Facilities Department/Joan Meyers**

Sponsored By: Councilmember Swiatek, Supervisor Holtz

WHEREAS, a temporary vacancy existed in the position of Clerk Typist in the Facilities Department; AND

WHEREAS, said vacancy was for no more than thirty (30) days; AND

WHEREAS, there was an immediate need to fill said vacancy; AND

WHEREAS, Joan C. Meyers, currently employed as a part-time Clerk in the Facilities Department, was erroneously appointed to the title of Clerk (Temporary); NOW, THEREFORE, BE IT

RESOLVED, that Joan C. Meyers' appointment be and hereby is amended to Clerk Typist (Temporary) in the Facilities Department in accordance with the terms and conditions of the Town's collective bargaining agreement with the Town of Cheektowaga Employees Association effective January 5 through February 1, 2011.

RESULT:	ADOPTED [UNANIMOUS]
MOVER:	Jeff Swiatek, Councilmember
SECONDER:	Mary Holtz, Supervisor
AYES:	Holtz, Jaworowicz, Swiatek, Rogowski, Zydel, Markel, Kaznowski



19. RESOLUTION 2011-81

Appointment of Senior Clerk Typist (Competitive/Permanent) Building and Plumbing Department/Carol E. Driscoll

Sponsored By: Councilmember Swiatek, Supervisor Holtz

WHEREAS, a vacancy exists in the position of Senior Clerk Typist in the Building and Plumbing Department; AND

WHEREAS, notice of such vacancy has been posted in accordance with the provisions of the Town's collective bargaining agreement with the Town of Cheektowaga Employees Association; AND

WHEREAS, such job title is in the competitive class of Civil Service; AND

WHEREAS, a current Erie County Civil Service promotional list is in existence for said title; AND

WHEREAS, Carol E. Driscoll, currently employed as a Clerk Typist in the Police Department, appears on the existing Civil Service promotional list and meets all the necessary qualifications for appointment; NOW, THEREFORE, BE IT

RESOLVED, that Carol E. Driscoll of Cheektowaga, New York, be and hereby is appointed to the position of Senior Clerk Typist in the Building and Plumbing Department in accordance with the terms and conditions of the Town's collective bargaining agreement with the Town of Cheektowaga Employees Association effective February 28, 2011.

RESULT:	ADOPTED [UNANIMOUS]
MOVER:	Jeff Swiatek, Councilmember
SECONDER:	Mary Holtz, Supervisor
AYES:	Holtz, Jaworowicz, Swiatek, Rogowski, Zydel, Markel, Kaznowski

**20. RESOLUTION 2011-82****Appointment of Sewer Maintenance Worker (Non-Competitive/Permanent) Sewer Maintenance Department/David G. Ford**

Sponsored By: Councilmember Swiatek, Supervisor Holtz

WHEREAS, a vacancy exists in the title of Sewer Maintenance Worker in the Sewer Maintenance Department; AND

WHEREAS, notice of said vacancy has been posted in accordance with the provisions of the Town's collective bargaining agreement with the Town of Cheektowaga Employees Association; AND

WHEREAS, David G. Ford, currently employed as a Maintenance Worker in the Facilities Department (Buildings and Grounds Division), bid on said position and meets the necessary qualifications for appointment; NOW, THEREFORE, BE IT

RESOLVED, that David G. Ford of Cheektowaga, New York, be and hereby is appointed to the position of Sewer Maintenance Worker in the Sewer Maintenance Department in accordance with the terms and conditions of the Town's collective bargaining agreement with the Town of Cheektowaga Employees Association effective February 8, 2011.

RESULT:	ADOPTED [UNANIMOUS]
MOVER:	Jeff Swiatek, Councilmember
SECONDER:	Mary Holtz, Supervisor
AYES:	Holtz, Jaworowicz, Swiatek, Rogowski, Zydel, Markel, Kaznowski

**21. RESOLUTION 2011-83****Travel Authorization Police Department/Police Officers
Michael Scapillato and Emil DeVincentis**

Sponsored By: Councilmember Jaworowicz, Councilmember Swiatek

WHEREAS, a School Resource Officer Course is being held February 21 through February 25, 2011 in Rochester, New York; AND

WHEREAS, Police Officers Michael Scapillato and Emil DeVincentis have requested authorization to attend said course; AND

WHEREAS, Police Chief Christine Ziemba has submitted a request for travel authorization along with the proper paperwork in a timely manner; AND

WHEREAS, the total cost to the Town shall not exceed \$1,791.12; AND

WHEREAS, these expenses have been budgeted by the Police Department; NOW, THEREFORE, BE IT

RESOLVED, that Police Officers Michael Scapillato and Emil DeVincentis be and hereby are authorized to attend the School Resource Officer Course being held February 21 through February 25, 2011 in Rochester, New York.

RESULT:	ADOPTED [UNANIMOUS]
MOVER:	Patricia Jaworowicz, Councilmember
SECONDER:	Jeff Swiatek, Councilmember
AYES:	Holtz, Jaworowicz, Swiatek, Rogowski, Zydel, Markel, Kaznowski

**22. RESOLUTION 2011-84****Travel Authorization Police Department/Police Officers Eric Broska, John Skonecki, Brian Wesoloski and Mark Zimmerman**

Sponsored By: Councilmember Jaworowicz, Councilmember Swiatek

WHEREAS, the New York Tactical Officers Association Exposition and Conference is being held April 12 through April 14, 2011 in Verona, New York; AND

WHEREAS, Police Officers Eric Broska, John Skonecki, Brian Wesoloski and Mark Zimmerman have requested authorization to attend said exposition and conference; AND

WHEREAS, Police Chief Christine Ziemba has submitted a request for travel authorization along with the proper paperwork in a timely manner; AND

WHEREAS, the total cost to the Town shall not exceed \$1,734.96; AND

WHEREAS, these expenses have been budgeted by the Police Department; NOW, THEREFORE, BE IT

RESOLVED, that Police Officers Eric Broska, John Skonecki, Brian Wesoloski and Mark Zimmerman be and hereby are authorized to attend the New York Tactical Officers Association Exposition and Conference being held April 12 through April 14, 2011 in Verona, New York.

RESULT:	ADOPTED [UNANIMOUS]
MOVER:	Patricia Jaworowicz, Councilmember
SECONDER:	Jeff Swiatek, Councilmember
AYES:	Holtz, Jaworowicz, Swiatek, Rogowski, Zydel, Markel, Kaznowski

V. Suspension of Rules

Motion by Councilmember Markel; Seconded by Councilmember Kaznowski to Waive the Rules to Include the Following Three (3) Resolutions. Motion Carried.
--



1. RESOLUTION 2011-85

Award of Bid - Equipment & Operators for Public Works Projects

Sponsored By: Councilmember Kaznowski, Councilmember Zydel

WHEREAS, the contract was awarded for the furnishing of Equipment and Operators for Public Works Projects in the Town of Cheektowaga on February 22, 2010, AND

WHEREAS, the contract allows for an annual renewal and cost adjustment based on the Consumer Price Index (CPI) as of December 31, 2010, AND

WHEREAS, the contractor has submitted the required documentation which has been reviewed and approved, NOW, THEREFORE, BE IT

RESOLVED, that the contract for the furnishing of Equipment and Operators for Public Works Projects in the Town of Cheektowaga for the period of March 1, 2011 to March 1, 2012 be extended for Nichols, Long and Moore Construction Corporation, 149 Gunville Road, Lancaster, New York 14086 for the unit prices of:

		Per 8 Hour Day
Item 1	Tandem Dump	\$ 706.44
Item 2	Hydraulic Backhoe, Rubber Tire	\$ 705.43
Item 3	Laborers	\$ 791.70
Item 4	Saw (Vermeer Track)	\$ 2.03
Item 5	Saw (Walk Behind)	\$ 1.02
Item 6	Equipment Truck Type A	\$ 1.02
Item 7	Equipment Truck Type B	\$ 1.02
Item 8	Shield 8' X 10'	\$ 1.02
Item 9	Shield 6' X 16'	\$ 1.02
Item 10	Transport Shield	\$ 1.02
Item 11	Roller, 3 Ton	\$ 1.02
Item 12	Hydraulic Backhoe, 1/3 yard	\$ 2.03
Item 13	Hydraulic Backhoe, 7/8 yard	\$1,004.85
Item 14	Hydraulic Backhoe, 1-1/3 yard	\$ 406.00
Item 15	Hydraulic Backhoe, 2-1/3 yard	\$ 507.50
Item 16	Dozer, D-3	\$ 2.03
Item 17	Dozer, D-4	\$ 558.25
Item 18	Dozer, D-6	\$ 2.03
Item 19	Front End Loader, 3 yard	\$ 507.50
Item 20	Landscape Tractor	\$ 1.02
Item 21	Hydraulic Backhoe w/min 4500 lb.	\$ 2.03
Item 22	Hydraulic Backhoe w/min 7500 lb.	\$ 2.03
Item 23	Hydraulic Backhoe w/min 8800 lb.	\$ 2.03
Item 24	Smooth Drum Dirt Roller, 4500 lb.	\$ 2.03

AND, BE IT FURTHER

RESOLVED, that payment for said Equipment and Operators for Public Works Projects

is to be chargeable on an as-needed basis by any Town departments who wish to avail themselves of this service within their appropriated budget items.

RESULT:	ADOPTED [UNANIMOUS]
MOVER:	Stanley Kaznowski, Councilmember
SECONDER:	Richard Zydel, Councilmember
AYES:	Holtz, Jaworowicz, Swiatek, Rogowski, Zydel, Markel, Kaznowski



2. RESOLUTION 2011-86

Authorize Supervisor to Execute Contracts for Special Events

Sponsored By: Supervisor Holtz, Councilmember Swiatek

BE IT RESOLVED, that subject to approval by the Town Attorney, the Supervisor be and hereby is authorized to execute contracts between the Town of Cheektowaga and vendors for special events to be held during the year 2011.

RESULT:	ADOPTED [UNANIMOUS]
MOVER:	Mary Holtz, Supervisor
SECONDER:	Jeff Swiatek, Councilmember
AYES:	Holtz, Jaworowicz, Swiatek, Rogowski, Zydel, Markel, Kaznowski



3. RESOLUTION 2011-87

Appointment of CEDC Directors

Sponsored By: Councilmember Swiatek, Supervisor Holtz

WHEREAS, the Town Board of the Town of Cheektowaga previously created the Cheektowaga Economic Development Corporation for the purpose of assisting and encouraging economic development within the Town, and

WHEREAS, By Resolution dated February 7, 1983 this Town Board approved the By-Laws of the Cheektowaga Economic Development Corporation which provide that the Directors of the Cheektowaga Economic Development Corporation be appointed by resolution of the Cheektowaga Town Board, and

WHEREAS, the Directors of the Cheektowaga Economic Development Corporation have recommended the appointment of the individual listed below to the Board of Directors of the Cheektowaga Economic Development Corporation, NOW, THEREFORE, BE IT

RESOLVED, that Edward Halady is hereby appointed to the Board of Directors of the Cheektowaga Economic Development Corporation, effective immediately for a term expiring at the time of reappointment to said Board of Directors positions but no later than June 30, 2013, AND BE IT

FURTHER RESOLVED, that the terms of the following individuals, appointed to the Board of Directors of the Cheektowaga Economic Development Corporation in 2009 to a term expiring no later than June 30, 2011, be extended by one year to a term expiring no later than June 30, 2012.

- Richard Cielinski
- Joseph Funk
- John Redman III.

RESULT:	ADOPTED [UNANIMOUS]
MOVER:	Jeff Swiatek, Councilmember
SECONDER:	Mary Holtz, Supervisor
AYES:	Holtz, Jaworowicz, Swiatek, Rogowski, Zydel, Markel, Kaznowski

VI. Communications

A. Departmental Communications

1. Building Permit List - January 2011
2. Minutes: Cheektowaga Conservation Advisory Council - January 6, 2011

3. Minutes: Town Environmental Advisory Committee - January 12, 2011
4. Minutes: Cheektowaga Planning Board - January 13, 2011
5. Minutes: Cheektowaga Public Library - Board of Trustees - January 12, 2011

B. General Communications

1. Summons: HSBC Mortgage Corp Vs. Janeen + Francis Roscoe, the Town of Cheektowaga & Etal Premises: 99 Jackson St.
2. Summons: Citimortgage Inc. Vs. Cynthia M. Malkiewicz Vs. Town of Cheektowaga Premises: 32 Randolph Ave.
3. Notice of Claim: Jeffery Cebulski Vs. Town of Cheektowaga
4. Notice of Claim: Todd Hariaczyi Vs. Town of Cheektowaga
5. Notice of Claim: Chris Panepinto Vs. Town of Cheektowaga
6. Notice of Claim: Mark Ralyea Vs. Town of Cheektowaga
7. Notice of Claim: Marie VanI derstine Vs. Town of Cheektowaga

VII. Comments

A. Supervisor's Comments

B. Councilmember's Comments

C. Public Comments

VIII. Adjournment

Motion by Supervisor Holtz; Seconded by Councilmember Jaworowicz to adjourn the meeting at 7:10 PM in Memory of Former Assessor Andrew Schwenk.

**PROPOSED AMENDMENT TO PARKS ORDINANCE
RELATING TO DOGS IN PARKS**

§174-8. Domestic animals prohibited from parks and park approaches, shall be amended, effective immediately and expiring on December 31, 2011, to read as follows:

§174-8. Domestic animals in parks and park approaches.

- A. Dogs shall be permitted in town parks, except for John C. Stiglmeier Park and Cheektowaga Town Park, subject to the following conditions/limitations:
 - i. Dogs must be restrained/hand-controlled by leash (no longer than six feet in length); and
 - ii. No person walking or in charge of any dog in said area(s) shall cause, suffer or allow such dog to soil, defecate on or commit any nuisance in said area (unless said person picks up and properly disposes of the feces in an appropriate container);
 - iii. Dogs shall not be permitted on any park lands designated for sport fields and/or in areas immediately adjacent to playground structures.

- B. Dogs shall be permitted in the area designated as the Alexander Walking Path (described as follows: being the park area/walking trail area on the east side of Scajauada Creek east and north of the Alexander Community Center, but not including any area east of the parking lot for the Cheektowaga Recreation Center/Ice Rink building), subject to the conditions/limitations contained in subsections A.i., A.ii. and A.iii. of this section.

- C. This amendment shall become effective _____ and shall expire on December 31, 2011.



Town of Cheektowaga

Regular Meeting

~ Minutes ~

3301 Broadway
Cheektowaga, NY 14227
<http://www.town.cheektowaga.ny.us>

Alice Magierski
716-686-3400

Wednesday, February, 23, 2011

6:45 PM

Council Chambers

I. Call to Order

6:45 PM Meeting called to order on February 23, 2011 at Council Chambers, 3301 Broadway St, Cheektowaga, NY.

Attendee Name	Organization	Title	Status	Arrived
Mary Holtz	Town of Cheektowaga	Supervisor	Present	
Patricia Jaworowicz	Town of Cheektowaga	Councilmember	Present	
Jeff Swiatek	Town of Cheektowaga	Councilmember	Present	
James Rogowski	Town of Cheektowaga	Councilmember	Present	
Richard Zydel	Town of Cheektowaga	Councilmember	Present	
Charles Markel	Town of Cheektowaga	Councilmember	Present	
Stanley Kaznowski	Town of Cheektowaga	Councilmember	Present	

2. Additional Attendees

Jerry Gabryszak, Director of Community Development
John Marriott, Planning Board Chairman
Frank Max, General Crew Chief, Sanitation
William Pugh, Town Engineer
Kevin Schenk, Town Attorney
Kerry Switalski, Senior Services Director
Christine Ziemba, Chief of Police

II. Public Comment Period

III. Resolutions



1. RESOLUTION 2011-88

“Christine Ziembra Day” in the Town of Cheektowaga Proclaimed

Sponsored By: Markel, Rogowski, Swiatek, Holtz, Jaworowicz, Zydel, Kaznowski

WHEREAS Cheektowaga Police Chief Christine Ziembra has announced that she will be retiring at the end of February, 2011 bringing to a close a history-making career with the Town of Cheektowaga as our town’s first female police officer and first female Chief of Police; and

WHEREAS Chief Christine Ziembra was first appointed to the position of police officer in 1976 and has served as Chief of Police for the past nine years; and

WHEREAS Chief Christine Ziembra had a vision for the operation of our Police Department and excelled at the position of Chief of Police with outstanding foresight and a keen understanding of the changing nature of our population, our neighborhoods, family dynamics, youth issues and criminal activity; and

WHEREAS Chief Christine Ziembra instituted many law enforcement best practices and always sought to keep the lines of communication open with the public including creation of the Citizens Police Academy which many of our residents have attended and gained a better understanding of police work and how it relates to the community; and

WHEREAS Chief Christine Ziembra has chosen to move on to the next phase of her life, with her husband, after devoting 34 years to the Town of Cheektowaga and her career NOW, THEREFORE, BE IT

RESOLVED that Monday, February 28, 2011, the first day of her retirement from a history-making career, be and hereby is officially proclaimed “Christine Ziembra Day” in the Town of Cheektowaga; and BE IT FURTHER

RESOLVED that the Cheektowaga Town Board, on behalf of our residents, extends sincere congratulations to Chief Christine Ziembra for a job well done and best wishes for a well-deserved retirement.

RESULT:	ADOPTED [UNANIMOUS]
MOVER:	Charles Markel, Councilmember
SECONDER:	James Rogowski, Councilmember
AYES:	Holtz, Jaworowicz, Swiatek, Rogowski, Zydel, Markel, Kaznowski



2. RESOLUTION 2011-89

Transfer of Funds

Sponsored By: Supervisor Holtz, Councilmember Swiatek

BE IT RESOLVED, that the following transfer is hereby approved and made a part hereof;

2011

GENERAL FUND

FROM:	100.1910.2655	Minor Sales	\$ 2,981.98
TO:	100.1680.2204	Computer Hardware	\$ 2,981.98

HIGHWAY FUND

FROM:	300.1910.2680	Insurance Recoveries	\$ 2,223.88
TO:	300.5130.4462	Parts & Supplies	\$ 2,223.88

SPECIAL DISTRICTS FUND

FROM:	990.1910.2681	Light Standard Damages	\$ 785.00
TO:	990.5182.4432	Repairs & Maintenance	\$ 785.00

RESULT:	ADOPTED [UNANIMOUS]
MOVER:	Mary Holtz, Supervisor
SECONDER:	Jeff Swiatek, Councilmember
AYES:	Holtz, Jaworowicz, Swiatek, Rogowski, Zydel, Markel, Kaznowski



3. RESOLUTION 2011-90

Warrant

Sponsored By: Supervisor Holtz, Councilmember Swiatek

BE IT RESOLVED, that the following Vouchers & Warrants submitted to the Town of Cheektowaga prior to February 18, 2011 are hereby approved and made a part hereof;

GENERAL FUND	\$ 3,236,002.55
RISK RETENTION FUND	155,228.84
NYS HOME PROGRAM	550.00
DEBT SERVICE FUND	765,831.25
HUD HOUSING REHABILITATION	8,886.00
SPECIAL DISTRICTS FUND	4,698,004.68
HIGHWAY FUND	968,519.07
CAPITAL FUND	164,261.63
TRUST & AGENCY FUND	11,883.89
HUD CDBG FUND	36,997.48
PART TOWN FUND	155,259.95
NYS AFFORDABLE HOUSING	5,024.00
	<u>\$ 10,206,449.34</u>

RESULT:	ADOPTED [UNANIMOUS]
MOVER:	Mary Holtz, Supervisor
SECONDER:	Jeff Swiatek, Councilmember
AYES:	Holtz, Jaworowicz, Swiatek, Rogowski, Zydel, Markel, Kaznowski



4. RESOLUTION 2011-91

Issue Negative SEQR Declaration for 4822 Genesee Street

Sponsored By: Councilmember Markel, Councilmember Kaznowski

WHEREAS, pursuant to the Environmental Impact Review Ordinance of the Town of Cheektowaga, the Environmental Advisory Committee ("EAC") reviews various applications for site plans, rezonings, special permits, etc. and renders its recommendation concerning the environmental significance of such application, AND

WHEREAS, the Town Board, pursuant to the Environmental Impact Review Ordinance of the Town of Cheektowaga, is designated the Lead Agency in most instances, AND

WHEREAS, since the Town Board is the Lead Agency, it must affirm, modify or reject any recommendations submitted to it by the Advisory Committee, AND

WHEREAS, an application was submitted by Michael J. Metzger, P.E. for M.P. Carol Hardwood for the redevelopment of an existing retail flooring store at 4822 Genesee Street, AND

WHEREAS, the project includes the demolition of an existing 2,080 square foot building and the construction of a replacement 12,000 square foot building, including accessory parking, AND

WHEREAS, the Environmental Advisory Committee at its meetings held on February 9, 2011 recommended a determination of non-significance, subject to the Town's receipt of evidence that NYS Office of Parks and Recreation has no concerns for the presence of archeological resources, AND

WHEREAS, the Town of Cheektowaga Planning Board recommended approval of the site plan at their meeting of January 13, 2011, AND

WHEREAS, the applicant has indicated that he will provide a public walk along his entire road frontage at a future date as directed by the Town of Cheektowaga, AND

WHEREAS, this Town Board has reviewed the application submitted and the recommendations made by the Environmental Advisory Committee and the Planning Board NOW, THEREFORE, BE IT

RESOLVED, that this Town Board determines that the project will not have a significant effect on the environment and therefore issues a Negative Declaration for purposes of SEQRA, AND BE IT

FURTHER RESOLVED, the proposed site plan is found to be acceptable subject to :

1. The Town Engineer reviewing and approving the grading/drainage plan.
2. The applicant provide written confirmation from the NYS Office of Parks Recreation and Historic Preservation that the site does not possess cultural resources.

RESULT:	ADOPTED [UNANIMOUS]
MOVER:	Charles Markel, Councilmember
SECONDER:	Stanley Kaznowski, Councilmember
AYES:	Holtz, Jaworowicz, Swiatek, Rogowski, Zydel, Markel, Kaznowski



5. RESOLUTION 2011-92

Issue Negative SEQR Declaration - East of 609 Dingens Street

Sponsored By: Councilmember Markel, Councilmember Kaznowski

WHEREAS, pursuant to the Environmental Impact Review Ordinance of the Town of Cheektowaga, the Environmental Advisory Committee ("EAC") reviews various applications for site plans, rezonings, special permits, etc. and renders its recommendation concerning the environmental significance of such application, AND

WHEREAS, the Town Board, pursuant to the Environmental Impact Review Ordinance of the Town of Cheektowaga, is designated the Lead Agency in most instances, AND

WHEREAS, since the Town Board is the Lead Agency, it must affirm, modify or reject any recommendations submitted to it by the Advisory Committee, AND

WHEREAS, an application was submitted by Roberts Shackleton Boy, Architects and Engineers with the permission of the land owner, the Town of Cheektowaga for rezoning of 0.93 acres of vacant land identified as SBL No. 123.28-7-2 from R- Residence to C- Retail Business for the construction of a two story, 12,000 square foot office building, AND

WHEREAS, the Environmental Advisory Committee at its meetings held on February 9, 2011 recommended a determination of non-significance, AND

WHEREAS, the Town of Cheektowaga Planning Board recommended approval of the rezoning request and site plan at their meeting of January 14, 2010, and reserved recommendation on architectural character/landscaping , AND

WHEREAS, the Town of Cheektowaga Traffic Safety Commission has reviewed the subject project and the traffic impact statement prepared by the applicant's consultant and is recommending approval of the subject project, AND

WHEREAS, this Town Board has reviewed the application submitted and the recommendations made by the Environmental Advisory Committee, the Planning Board and the Traffic Safety Commission, NOW, THEREFORE, BE IT

RESOLVED, that this Town Board determines that the project will not have a significant effect on the environment and therefore issues a Negative Declaration for purposes of SEQRA, AND BE IT

FURTHER RESOLVED, the proposed site plan is found to be acceptable subject to :

1. The Town Engineer reviewing/approving the drainage and grading plans.
2. The applicant providing a public walk along his/her road frontage.

RESULT: ADOPTED [UNANIMOUS]

MOVER: Charles Markel, Councilmember
SECONDER: Stanley Kaznowski, Councilmember
AYES: Holtz, Jaworowicz, Swiatek, Rogowski, Zydel, Markel, Kaznowski



6. RESOLUTION 2011-93

Approve Rezoning of Vacant Land on Dingens Street East of 609 Dingens Street

Sponsored By: Councilmember Markel, Councilmember Kaznowski

WHEREAS, the Town of Cheektowaga is the owner of 0.63 acre of land located east of 609 Dingens Street, and

WHEREAS, the Town of Cheektowaga entered into an agreement to sell such property to Gateway Development, LLC, and said purchase was contingent upon the purchaser having the property rezoned to C-Retail Business District, and

WHEREAS, Roberts, Shackleton & Boy, Architects petitioned for a rezoning from R-Residence District to C-Retail Business District for the aforementioned property owned by the Town of Cheektowaga and located east of 609 Dingens Street, Cheektowaga, New York which property is described in the attached legal description, for the construction of a two-story 12,000 square foot office building, and

WHEREAS, a public hearing on such petition was held before this Town Board on the 7th day of June, 2010 at 6:45 P.M., after publication and service of the notices required by the provisions of the Code of the Town of Cheektowaga ("Zoning Law"), and the Town Law; and all interested parties were given an opportunity to be heard at such hearing, and

WHEREAS, the Cheektowaga Planning Board has reviewed such application and has recommended approval thereof, and

WHEREAS, this Town Board previously issued a Negative Declaration under SEQRA and the Town Environmental Impact Review Ordinance for this rezoning, NOW, THEREFORE, BE IT

RESOLVED, that the application of Roberts, Shackleton & Boy for the rezoning from R-Residence District to C - Retail Business District for the property described in the attached legal description be and the same is hereby approved subject to the following condition:

- 1. Any future additions to the site plan must be resubmitted to the Town Board to determine that the addition is substantially in agreement with the intent of this rezoning;
2. Closing on the sale of said property by the Town of Cheektowaga, with grant of parking easement to the Town of Cheektowaga.

, and BE IT FURTHER

RESOLVED, that the Zoning Map and Law of the Town Of Cheektowaga be amended in accordance with the above.

LEGAL DESCRIPTION

ALL THAT TRACT OR PARCEL OF LAND situate in the Town of Cheektowaga, County of Erie and State of New York, being part of Lot No. 76, Township 10, Range 7 of the Buffalo

Creek Reservation, bounded and described as follows:

BEGINNING at a point in the centerline of Dingens Street, (width varies), being the south line of Lot No. 75 and the north line of Lot No. 76, where said centerline is intersected by the east line of Wagner Avenue, (50 feet wide), (an unimproved road); thence south 0° 00' 47" east, 384.22 feet to the north line of the lands conveyed to the New York State Thruway Authority by Notice of Appropriation recorded in the Erie County Clerk's Office in Liber 9287 of Deeds at page 356; thence easterly along said northerly boundary 116.88 feet to the west line of lands of Niagara Mohawk Power Corporation and the east line of Lot No. 76; thence north 0°05'28" west and along the west line of Niagara Mohawk Power Corporation and the east line of Lot No. 76, 383.85 feet to the centerline of Dingens Street; thence north 89°49'04" along the centerline of Dingens Street 116.36 feet to the point of beginning.

RESULT:	ADOPTED [UNANIMOUS]
MOVER:	Charles Markel, Councilmember
SECONDER:	Stanley Kaznowski, Councilmember
AYES:	Holtz, Jaworowicz, Swiatek, Rogowski, Zydel, Markel, Kaznowski



7. RESOLUTION 2011-94

Award of Bid for Work Uniforms

Sponsored By: Councilmember Kaznowski, Councilmember Zydel

WHEREAS, bids were received and publicly opened on February 2, 2011 for the furnishing of work uniforms to Town of Cheektowaga employees. Said bids were referred to the Town Engineer for analysis and tabulation, NOW, THEREFORE, BE IT

RESOLVED, that the contract for the furnishing of work uniforms to Town of Cheektowaga employees, as recommended by the Town Engineer, be and the same is hereby awarded to:

The Liberty Store
5 East Genesee Street
Auburn, New York 13021

BID ITEM 1

Item 1A	Work Pants (sizes to 44)	\$15.70
Item 1B	Work Pants (sizes 46-50)	\$17.23
Item 1C	Work Pants (sizes 52-60)	\$17.23
Item 2A	Shirts (long sleeve, sizes up to 2XL)	\$13.85
Item 2B	Shirts (long sleeve, sizes 3XL, 4XL, tall)	\$15.16
Item 3A	Chambray Shirts (long sleeve, sizes up to 2XL)	\$12.98
Item 3B	Chambray Shirts (long sleeve, sizes 3XL, 4XL, tall)	\$14.07
Item 4A	Shirts (short sleeve, sizes up to 2XL)	\$12.98
Item 4B	Shirts (short sleeve, sizes 3XL-5XL, tall)	\$14.07
Item 5A	Chambray Shirts (short sleeve, sizes up to 2XL)	\$11.45
Item 5B	Chambray Shirts (short sleeve, sizes 3XL, 4XL)	\$12.54
Item 6A	Coveralls (long sleeve, sizes 36-46, short - X long)	\$24.97
Item 6B	Coveralls (long sleeve, sizes 48-50, short - X long)	\$24.97
Item 6C	Coveralls (long sleeve, sizes 52-60, regular - tall)	\$28.38
Item 7A	Denim Jeans (sizes 28-44)	\$11.61

Item 7B	Denim Jeans (sizes 46-50)	\$12.98
Item 7C	Denim Jeans (sizes 52-56)	\$14.01
Item 8A	Bib Overalls (sizes to 44)	\$20.11
Item 8B	Bib Overalls (sizes 46-50)	\$21.70
Item 8C	Bib Overalls (52-60)	\$23.66
Item 9A	Women's Work Pants (sizes 4-20)	\$12.54
Item 9B	Women's Work Pants (sizes 22-28)	\$14.12

Quality Equipment Distributors, Inc.
70 Benbro Drive
Cheektowaga, New York 14225

BID ITEM II

Item 1A	High Visibility Jacket (sizes S-XL)	\$48.48
Item 1B	High Visibility Jacket (size 2XL)	\$48.48
Item 1C	High Visibility Jacket (size 3XL)	\$48.48
Item 1D	High Visibility Jacket (size 4XL)	\$48.48
Item 1E	High Visibility Jacket (size 5XL)	\$48.48
Item 1F	High Visibility Jacket (size 6XL)	\$48.48

The Liberty Store
5 East Genesee Street
Auburn, New York 13021

BID ITEM III

Item 1A	Hooded Pullover Sweatshirt (sizes S-XL)	\$12.60
Item 1B	Hooded Pullover Sweatshirt (size XXL)	\$14.60
Item 1C	Hooded Pullover Sweatshirt (size XXXL)	\$14.60
Item 1D	Hooded Pullover Sweatshirt (size XXXXL)	\$16.60
Item 2A	Hooded Zipper Sweatshirt (sizes S-XL)	\$17.25

Item 2B	Hooded Zipper Sweatshirt (size XXL)	\$19.25
Item 2C	Hooded Zipper Sweatshirt (size XXXL)	\$19.25
Item 3A	Heavy Duty Sweatshirt (sizes S-XL)	\$ 8.55
Item 3B	Heavy Duty Sweatshirt (size 2XL)	\$ 9.95
Item 3C	Heavy Duty Sweatshirt (size 3XL)	\$ 9.95
Item 3D	Heavy Duty Sweatshirt (size 4XL)	\$11.45
Item 6A	Tee Shirt (sizes M-XL)	\$ 3.37
	Pocket Tee Shirt (size M-XL)	\$ 4.85
Item 6B	Tee Shirt (size 2XL)	\$ 4.47
	Pocket Tee Shirt (size 2XL)	\$ 5.85
Item 6C	Tee Shirt (size 3XL)	\$ 4.47
	Pocket Tee Shirt (size 3XL)	\$ 5.85

BID ITEM IV

Carhartt Bib Overall (sizes 34-48)	\$68.40
Carhartt Bib Overall (size 50)	\$68.40

RESULT:	ADOPTED [UNANIMOUS]
MOVER:	Stanley Kaznowski, Councilmember
SECONDER:	Richard Zydel, Councilmember
AYES:	Holtz, Jaworowicz, Swiatek, Rogowski, Zydel, Markel, Kaznowski



8. RESOLUTION 2011-95

Award Bid for Softball Equipment 2011

Sponsored By: Councilmember Zydell, Councilmember Rogowski

WHEREAS, sealed bids were duly received by the Town Board at a bid opening on February 9, 2011 for the furnishing of baseball and softball equipment as a result of advertising thereof, and such bids were referred to the Department of Youth & Recreational Services, for analysis, tabulation and report, and

WHEREAS, such analysis, tabulation and report have been completed, BE IT

RESOLVED that bids be awarded to the lowest responsible bidder meeting specifications and to be in the best interest of the Town of Cheektowaga for the year 2011:

-- Laux Sporting Goods
25 Pineview Drive
Amherst, NY 14228

--Anaconda Sports
85 Katrine Lane
Lake Katrine, NY 12449

-- Jim Ludtka Sporting Goods, Inc.
3950 Broadway
Depew, NY 14043

BE IT FURTHER RESOLVED that the costs resulting from the awarding of this bid are funded through 7140; 7180; and 7310 accounts for cost centering purposes.

RESULT:	ADOPTED [UNANIMOUS]
MOVER:	Richard Zydell, Councilmember
SECONDER:	James Rogowski, Councilmember
AYES:	Holtz, Jaworowicz, Swiatek, Rogowski, Zydell, Markel, Kaznowski



9. RESOLUTION 2011-96

Award of Bid - Cold Milling of Various Town Highways

Sponsored By: Councilmember Kaznowski, Councilmember Zydel

WHEREAS, the contract was awarded for cold milling of various Town highways in the Town of Cheektowaga on March 15, 2010, AND

WHEREAS, the contract allows for an annual renewal, AND

WHEREAS, the contractor has submitted the required documentation which has been reviewed and approved, NOW, THEREFORE, BE IT

RESOLVED, that the contract for cold milling of various Town highways in the Town of Cheektowaga for the calendar year 2011 be extended for:

Swank Associated Companies, Inc.,
200 Hunt Valley Road
New Kensington, PA 15068

for the unit price of \$0.485 per square yard.

RESULT:	ADOPTED [UNANIMOUS]
MOVER:	Stanley Kaznowski, Councilmember
SECONDER:	Richard Zydel, Councilmember
AYES:	Holtz, Jaworowicz, Swiatek, Rogowski, Zydel, Markel, Kaznowski



10. RESOLUTION 2011-97

Notice to Bidders - Topsoil

Sponsored By: Councilmember Swiatek, Supervisor Holtz

WHEREAS, the Town Clerk be and hereby is directed to publish a Notice to Bidders for the purpose of furnishing TOPSOIL for use by the Cheektowaga Highway Department and various Departments in the Town.

Information for bidders and specifications may be obtained from the office of the Town Clerk, Cheektowaga Town Hall, Broadway and Union Roads, Cheektowaga, New York, between the hours of 9:00AM and 4:30PM, Monday through Friday, NOW THEREFORE BE IT

RESOLVED, that the Town Clerk is hereby designated as the Officer to open bids on the aforesaid items at a public bid opening to held on Wednesday March 9, 2011 at 11:00AM, in the Council Chambers of the Cheektowaga Town Hall.

NOTICE TO BIDDERS
TOWN OF CHEEKTOWAGA, NEW YORK

SEALED PROPOSALS will be received and considered by the Cheektowaga Town Clerk on March 9, 2011 at a public bid opening at 11:00 AM, at the Town Hall located on Broadway and Union Roads, Cheektowaga, NY, for the purpose of furnishing TOPSOIL for use by various departments in the Town of Cheektowaga.

Specifications may be picked up at the office of the Town Clerk, Cheektowaga Town hall, Broadway and Union Road, Cheektowaga, NY, between the hours of 9:00 AM and 4:30 PM, Monday through Friday.

NON-COLLUSION FORMS MUST BE SIGNED AND SUBMITTED WITH EACH BID.

ALICE MAGIERSKI
TOWN CLERK
TOWN OF CHEEKTOWAGA

DATED: February , 2011

Table with 2 columns: Field (RESULT, MOVER, SECONDER, AYES) and Value (ADOPTED [UNANIMOUS], Jeff Swiatek, Councilmember, Mary Holtz, Supervisor, Holtz, Jaworowicz, Swiatek, Rogowski, Zydel, Markel, Kaznowski)



11. RESOLUTION 2011-98

Approve Cultural Group Funding for Arts Society and Friends of the Woods

Sponsored By: Councilmember Rogowski, Councilmember Zydel

WHEREAS, the Town, in its 2011 budget, allocated moneys to certain cultural and not-for-profit organizations which are involved in activities which benefit the Town, and

WHEREAS, agreement(s) between the Town and these cultural and not-for-profit organizations have been prepared and forwarded to such groups, and

WHEREAS, the organization(s) listed below have completed and returned signed agreement(s) and their accounting report(s) from the 2010 funding to the Town, NOW, THEREFORE, BE IT

RESOLVED, that this Town Board hereby approves agreement(s) with the cultural and not-for-profit organization(s) listed below for the amount(s) listed, and BE IT FURTHER

RESOLVED, that the Supervisor be and hereby is authorized and directed to execute agreement(s) with the following referenced cultural and not-for-profit organization(s) for the following respective amount(s):

<u>Cultural/Not-For-Profit Organization</u>	<u>Funding Approved</u>
Arts Society of Cheektowaga	\$1,200.00
Friends of the Woods, Ltd.	\$800.00

and BE IT FURTHER

RESOLVED, that the aforementioned moneys shall be paid to the respective cultural/not-for-profit organization(s) out of the respective cultural group budget line item(s) in the 2011 Town budget, subject to audit and approval of a properly signed Town voucher.

RESULT:	ADOPTED [UNANIMOUS]
MOVER:	James Rogowski, Councilmember
SECONDER:	Richard Zydel, Councilmember
AYES:	Holtz, Jaworowicz, Swiatek, Rogowski, Zydel, Markel, Kaznowski



12. RESOLUTION 2011-99

Execute Final Contract Acceptance Documents with Northeast Mechanical Inc.

Sponsored By: Supervisor Holtz, Councilmember Jaworowicz

WHEREAS, the contract for HVAC/Electrical Improvements at the Town Records Center was awarded by Town Board Resolution dated February 22, 2010 to Northeast Mechanical Inc. in the amount of \$31,889.00, AND

WHEREAS, the Town Engineer has advised that work under the aforesaid contract has been completed in accordance with the contract requirements, NOW, THEREFORE, BE IT

RESOLVED, that this Town Board hereby accepts the completed project and directs the Supervisor to execute the final contract acceptance documents with Northeast Mechanical Inc., 139 Sawyer Avenue, Depew, New York 14043.

RESULT:	ADOPTED [UNANIMOUS]
MOVER:	Mary Holtz, Supervisor
SECONDER:	Patricia Jaworowicz, Councilmember
AYES:	Holtz, Jaworowicz, Swiatek, Rogowski, Zydel, Markel, Kaznowski



13. RESOLUTION 2011-100

Authorize Supervisor to Sign Contract with Palladian

Sponsored By: Councilmember Zydel, Councilmember Rogowski

WHEREAS, since 2008 The Department of Youth & Recreational Services has been a program provider with Blue Cross & Blue Shield of WNY's "Aqua" and "Lifestyle Benefit" programs and

WHEREAS, customers whose employers participate in said programs will be able to apply benefits toward registration fees for several Youth & Recreational Services children's fitness programs, NOW THEREFORE BE IT,

RESOLVED, that subject to approval by the Town Attorney, Supervisor Mary Holtz be and hereby is authorized to sign a two year re-credentialing agreement between the Town and Palladian Muscular Skeletal Health, the administrating agency for the "Aqua" and "Lifestyle Benefit" programs.

RESULT:	ADOPTED [UNANIMOUS]
MOVER:	Richard Zydel, Councilmember
SECONDER:	James Rogowski, Councilmember
AYES:	Holtz, Jaworowicz, Swiatek, Rogowski, Zydel, Markel, Kaznowski



14. RESOLUTION 2011-101

Approve Disposal of Obsolete Computer Equipment

Sponsored By: Supervisor Holtz, Councilmember Jaworowicz

WHEREAS, the Town wishes to dispose of a VAX computer system and corresponding computer tapes which are obsolete, unusable, and have no market value; and

WHEREAS, the destruction of such property is authorized by Section 64 of the Town Law of the State of New York; and

WHEREAS, Regional Computer Recycling & Recovery of Victor, New York will pick-up said equipment and dispose of same in full compliance with all government regulations applicable to the disposal, at a cost not to exceed \$50.00; NOW THEREFORE, BE IT

RESOLVED, that the Town hereby authorizes Regional Computer Recycling and Recovery to take possession of the equipment set forth below and dispose of same in full compliance with all applicable federal and state regulations governing the disposal; BE IT FURTHER

RESOLVED, that the Supervisor of the Town of Cheektowaga be and hereby is authorized to execute any document necessary effect the proper disposal of said equipment; and BE IT FURTHER

RESOLVED, that the cost associated with the disposal of said equipment shall be appropriated from account number 100-1680-4147.

RESULT:	ADOPTED [UNANIMOUS]
MOVER:	Mary Holtz, Supervisor
SECONDER:	Patricia Jaworowicz, Councilmember
AYES:	Holtz, Jaworowicz, Swiatek, Rogowski, Zydel, Markel, Kaznowski



15. RESOLUTION 2011-102

Correct Hourly Rate for Cellblock Attendants

Sponsored By: Supervisor Holtz, Councilmember Jaworowicz

WHEREAS, the hourly rate for Cell Block Attendants was established for 2011 per resolution 2010-689, and

WHEREAS, this hourly rate of \$15.60 was incorrect and should have been \$16.10, THEREFORE,

BE IT RESOLVED, that the hourly rate for Cell Block Attendants be established at \$16.10 as of January 1, 2011.

RESULT:	ADOPTED [UNANIMOUS]
MOVER:	Mary Holtz, Supervisor
SECONDER:	Patricia Jaworowicz, Councilmember
AYES:	Holtz, Jaworowicz, Swiatek, Rogowski, Zydel, Markel, Kaznowski



16. RESOLUTION 2011-103

Youth & Recreation Transfers

Sponsored By: Councilmember Zydel, Councilmember Rogowski

BE IT RESOLVED that the individuals listed below be and hereby are hired and/or transferred, as indicated, in the Department of Youth & Recreational Services, effective immediately:

Recreation Attendant - 7140.1646 - \$8.00 - Regular Part-time

Steven Gasiroek

Recreation Attendant - 7140.1627 - \$7.75 - Regular Part-time

Dan Kruszynski

Motion by Councilmember Rogowski; Seconded by Supervisor Holtz to waive the reading of Names for the following two (2) resolutions 2011-103 and 2011-104. Motion Carried

RESULT: ADOPTED [UNANIMOUS]
MOVER: Richard Zydel, Councilmember
SECONDER: James Rogowski, Councilmember
AYES: Holtz, Jaworowicz, Swiatek, Rogowski, Zydel, Markel, Kaznowski



17. RESOLUTION 2011-104

Part Time/Seasonal Appointments/Terminations

Sponsored By: Councilmember Swiatek, Supervisor Holtz

BE IT RESOLVED, that the following individual be and hereby is hired as a **SEASONAL EMPLOYEE**, not to exceed five (5) months in a calendar year, in the department listed and in compliance with Civil Service Laws and Regulations as well as the provisions of the Town's collective bargaining agreement between the Town of Cheektowaga and the Town of Cheektowaga Employees Association:

MAIN PUMP STATION Laborer \$8.50/hour effective 2/28/11
Ronald A. Strong, Cheektowaga

BE IT RESOLVED, that the following individuals be and hereby are hired as **PART-TIME EMPLOYEES** in the department listed, not to exceed nineteen (19) hours on a weekly basis, in compliance with Civil Service Laws and Regulations as well as the provisions of the Town's collective bargaining agreement between the Town of Cheektowaga and the Town of Cheektowaga Employees Association:

POLICE DEPARTMENT Detention Officer \$16.10/hour effective 2/24/11
Eric R. Weigand, Cheektowaga
Michael A. McCall, Cheektowaga

BE IT RESOLVED, that the following seasonal and/or part-time employees be and hereby are terminated as listed:

POLICE DEPARTMENT
Alan Minotti effective 2/7/11

JUSTICE COURT
John Kozak effective 1/10/11

FACILITIES DEPARTMENT
Brian M. Rogowski effective 2/28/11

RESULT:	ADOPTED [UNANIMOUS]
MOVER:	Jeff Swiatek, Councilmember
SECONDER:	Mary Holtz, Supervisor
AYES:	Holtz, Jaworowicz, Swiatek, Rogowski, Zydel, Markel, Kaznowski



18. RESOLUTION 2011-105

Appointment of Police Chief (Competitive/Permanent) Police Department/David J. Zack

Sponsored By: Markel, Rogowski, Swiatek, Holtz, Jaworowicz, Zydel, Kaznowski

WHEREAS, a vacancy exists in the title of Police Chief in the Police Department; AND

WHEREAS, said job title is in the competitive class of civil service; AND

WHEREAS, the existing civil service list was canvassed, interviews conducted and work performance reviews studied; AND

WHEREAS, David J. Zack, currently employed as a Police Captain in the Police Department, appears on the existing civil service list and meets the necessary qualifications for appointment; NOW, THEREFORE, BE IT

RESOLVED, that Police Captain David J. Zack of Depew, New York, be and hereby is appointed to the position of Police Chief in the Police Department effective February 26, 2011.

RESULT:	ADOPTED [UNANIMOUS]
MOVER:	Charles Markel, Councilmember
SECONDER:	James Rogowski, Councilmember
AYES:	Holtz, Jaworowicz, Swiatek, Rogowski, Zydel, Markel, Kaznowski



19. RESOLUTION 2011-106

Appointment of Police Captains (Competitive/Permanent) Police Department/Michael J. Sliwinski and Michael J. Isbrandt

Sponsored By: Councilmember Jaworowicz, Councilmember Swiatek

WHEREAS, two (2) vacancies exist in the position of Police Captain in the Police Department; AND

WHEREAS, said job title is in the competitive class of civil service; AND

WHEREAS, the existing civil service list was canvassed, interviews conducted and work performance reviews studied; AND

WHEREAS, Michael J. Sliwinski and Michael J. Isbrandt, both currently employed as Police Lieutenants in the Police Department, appear on the existing civil service list and meet the necessary qualifications for appointment; NOW, THEREFORE, BE IT

RESOLVED, that Police Lieutenants Michael J. Sliwinski of Cheektowaga, New York, and Michael J. Isbrandt of Cheektowaga, New York, be and hereby are appointed to the position of Police Captain in the Police Department in accordance with the terms and conditions of the Town's collective bargaining agreement with the Town of Cheektowaga Captains and Lieutenants Association effective February 26, 2011.

RESULT:	ADOPTED [UNANIMOUS]
MOVER:	Patricia Jaworowicz, Councilmember
SECONDER:	Jeff Swiatek, Councilmember
AYES:	Holtz, Jaworowicz, Swiatek, Rogowski, Zydel, Markel, Kaznowski



20. RESOLUTION 2011-107

Appointment of Police Lieutenants (Competitive/Permanent) Police Department/Brian J. Gould and Christina N. Newman

Sponsored By: Councilmember Jaworowicz, Councilmember Swiatek

WHEREAS, two (2) vacancies exist in the position of Police Lieutenant in the Police Department; AND

WHEREAS, said job title is in the competitive class of civil service; AND

WHEREAS, the existing civil service list was canvassed, interviews conducted and work performance reviews studied; AND

WHEREAS, Brian J. Gould and Christina N. Newman, both currently employed as Police Sergeants in the Police Department, appear on the existing civil service list and meet the necessary qualifications for appointment; NOW, THEREFORE, BE IT

RESOLVED, that Police Sergeants Brian J. Gould of Cheektowaga, New York, and Christina N. Newman of Cheektowaga, New York, be and hereby are appointed to the position of Police Lieutenant in accordance with the terms and conditions of the Town's collective bargaining agreement with the Town of Cheektowaga Captains and Lieutenants Association in the Police Department effective February 26, 2011.

RESULT:	ADOPTED [UNANIMOUS]
MOVER:	Patricia Jaworowicz, Councilmember
SECONDER:	Jeff Swiatek, Councilmember
AYES:	Holtz, Jaworowicz, Swiatek, Rogowski, Zydel, Markel, Kaznowski



21. RESOLUTION 2011-108

Appointment of Police Sergeants (Competitive/Permanent) Police Department/Dana J. Cadwallader and Nathan L. Frank

Sponsored By: Councilmember Jaworowicz, Councilmember Swiatek

WHEREAS, two (2) vacancies exist in the position of Police Sergeant in the Police Department; AND

WHEREAS, said job title is in the competitive class of civil service; AND

WHEREAS, the existing civil service list was canvassed, interviews conducted and work performance reviews studied; AND

WHEREAS, Dana J. Cadwallader and Nathan L. Frank, both currently employed as Police Officers in the Police Department, appear on the existing civil service list and meet the necessary qualifications for appointment; NOW, THEREFORE, BE IT

RESOLVED, that Police Officers Dana J. Cadwallader of Cheektowaga, New York, and Nathan L. Frank of Cheektowaga, New York, be and hereby are appointed to the position of Police Sergeant in the Police Department in accordance with the terms and conditions of the Town's collective bargaining agreement with the Cheektowaga Police Club effective February 26, 2011.

RESULT:	ADOPTED [UNANIMOUS]
MOVER:	Patricia Jaworowicz, Councilmember
SECONDER:	Jeff Swiatek, Councilmember
AYES:	Holtz, Jaworowicz, Swiatek, Rogowski, Zydel, Markel, Kaznowski



22. RESOLUTION 2011-109

Appointment of Public Safety Dispatcher (Competitive/Permanent) Police Department/Brian M. Rogowski

Sponsored By: Councilmember Jaworowicz, Councilmember Swiatek

WHEREAS, a vacancy exists in the position of Public Safety Dispatcher in the Police Department; AND

WHEREAS, said vacancy is in the competitive class of civil service; AND

WHEREAS, the existing civil service list was canvassed and interviews conducted; AND

WHEREAS, Brian M. Rogowski appears on said civil service list and meets the necessary qualifications for appointment; NOW, THEREFORE, BE IT

RESOLVED, that Brian M. Rogowski of Cheektowaga, New York, be and hereby is appointed to the position of Public Safety Dispatcher in the Police Department in accordance with the terms and conditions of the Town's collective bargaining agreement with the Town of Cheektowaga Public Safety Dispatchers Association effective February 28, 2011.

RESULT:	ADOPTED [UNANIMOUS]
MOVER:	Patricia Jaworowicz, Councilmember
SECONDER:	Jeff Swiatek, Councilmember
AYES:	Holtz, Jaworowicz, Swiatek, Rogowski, Zydel, Markel, Kaznowski



23. RESOLUTION 2011-110

Appointment of Maintenance Worker (Labor/Permanent) Facilities Department - Buildings and Grounds Division/Dennis J. O'Brien

Sponsored By: Councilmember Swiatek, Supervisor Holtz

WHEREAS, a vacancy exists in the title of Maintenance Worker in the Facilities Department (Buildings and Grounds Division); AND

WHEREAS, the Town of Cheektowaga Employees Association has agreed to waive the posting of said vacancy; AND

WHEREAS, an intra-departmental poll was conducted; AND

WHEREAS, Dennis J. O'Brien, currently employed as a General Mechanic in the Facilities Department (Parks Division), meets the necessary qualifications for appointment; NOW, THEREFORE, BE IT

RESOLVED, that Dennis J. O'Brien of Cheektowaga, New York, be and hereby is appointed to the position of Maintenance Worker in the Facilities Department (Buildings and Grounds Division) in accordance with the terms and conditions of the Town's collective bargaining agreement with the Town of Cheektowaga Employees Association effective February 8, 2011.

RESULT:	ADOPTED [UNANIMOUS]
MOVER:	Jeff Swiatek, Councilmember
SECONDER:	Mary Holtz, Supervisor
AYES:	Holtz, Jaworowicz, Swiatek, Rogowski, Zydel, Markel, Kaznowski



24. RESOLUTION 2011-111

Appointment of Clerk Typist (Competitive/Permanent) Police Department/Lynn M. Armstrong

Sponsored By: Councilmember Jaworowicz, Councilmember Swiatek

WHEREAS, a vacancy exists in the title of Clerk Typist in the Police Department; AND

WHEREAS, notice of such vacancy has been posted in accordance with the provisions of the Town's collective bargaining agreement with the Town of Cheektowaga Employees Association; AND

WHEREAS, no full-time bargaining unit member bid on said vacancy; AND

WHEREAS, said job title is in the competitive class of civil service; AND

WHEREAS, the existing civil service list was canvassed and interviews conducted; AND

WHEREAS, Lynn M. Armstrong appears on said civil service list and meets the necessary qualifications for appointment; NOW, THEREFORE, BE IT

RESOLVED, that Lynn M. Armstrong of Cheektowaga, New York, be and hereby is appointed to the position of Clerk Typist in the Police Department in accordance with the terms and conditions of the Town's collective bargaining agreement with the Town of Cheektowaga Employees Association effective February 28, 2011.

RESULT:	ADOPTED [UNANIMOUS]
MOVER:	Patricia Jaworowicz, Councilmember
SECONDER:	Jeff Swiatek, Councilmember
AYES:	Holtz, Jaworowicz, Swiatek, Rogowski, Zydel, Markel, Kaznowski



25. RESOLUTION 2011-112

Travel Authorization Accounting Department (Director of Administration and Finance Brian M. Krause)

Sponsored By: Councilmember Swiatek, Supervisor Holtz

WHEREAS, the New York State Government Finance Officers Association Annual Conference is being held April 6 through April 8, 2011 in Albany, New York; AND

WHEREAS, Director of Administration and Finance Brian M. Krause has requested authorization to attend said conference; AND

WHEREAS, Mr. Krause has submitted a request for travel authorization along with the proper paperwork in a timely manner; AND

WHEREAS, the total cost to the Town shall not exceed \$880.50; AND

WHEREAS, these expenses have been budgeted by the Accounting Department; NOW, THEREFORE, BE IT

RESOLVED, that Director of Administration and Finance Brian M. Krause be and hereby is authorized to attend the New York State Government Finance Officers Association Annual Conference being held April 6 through April 8, 2011 in Albany, New York.

RESULT:	ADOPTED [UNANIMOUS]
MOVER:	Jeff Swiatek, Councilmember
SECONDER:	Mary Holtz, Supervisor
AYES:	Holtz, Jaworowicz, Swiatek, Rogowski, Zydel, Markel, Kaznowski



26. RESOLUTION 2011-113

Travel Authorization (Police Department) Captain David Zack, Sergeants Lawrence Bauer and Thomas Allen, Detective David Mossman

Sponsored By: Councilmember Jaworowicz, Councilmember Swiatek

WHEREAS, Recognition, Prevention and Management of Excited Delirium and Sudden, In-Custody Deaths Instructor Training is being held March 16 through March 17, 2011 in Poughkeepsie, New York; AND

WHEREAS, Captain David Zack, Sergeants Lawrence Bauer and Thomas Allen, and Detective David Mossman have requested authorization to attend said training; AND

WHEREAS, Police Chief Christine Ziemba has submitted a request for travel authorization along with the proper paperwork in a timely manner; AND

WHEREAS, the total cost to the Town shall not exceed \$2,072; AND

WHEREAS, these expenses have been budgeted by the Police Department; NOW, THEREFORE, BE IT

RESOLVED, that Captain David Zack, Sergeants Lawrence Bauer and Thomas Allen, and Detective David Mossman be and hereby are authorized to attend Recognition, Prevention and Management of Excited Delirium and Sudden, In-Custody Deaths Instructor Training being held March 16 through March 17, 2011 in Poughkeepsie, New York.

RESULT:	ADOPTED [UNANIMOUS]
MOVER:	Patricia Jaworowicz, Councilmember
SECONDER:	Jeff Swiatek, Councilmember
AYES:	Holtz, Jaworowicz, Swiatek, Rogowski, Zydel, Markel, Kaznowski



27. RESOLUTION 2011-114

Travel Authorization Police Department (Detective Michael Hockwater)

Sponsored By: Councilmember Jaworowicz, Councilmember Swiatek

WHEREAS, a course entitled, "Domestic Violence Response and Investigation" is being held March 14 through March 16, 2011 in San Diego, California; AND

WHEREAS, Detective Michael Hockwater has requested authorization to attend said course; AND

WHEREAS, Police Chief Christine Ziemba has submitted a request for travel authorization along with the proper paperwork in a timely manner; AND

WHEREAS, the total cost to the Town shall not exceed \$415.75; AND

WHEREAS, these expenses have been budgeted by the Police Department; NOW, THEREFORE, BE IT

RESOLVED, that Detective Michael Hockwater be and hereby is authorized to attend the course entitled, "Domestic Violence Response and Investigation" being held March 14 through March 16, 2011 in San Diego, California.

RESULT:	ADOPTED [UNANIMOUS]
MOVER:	Patricia Jaworowicz, Councilmember
SECONDER:	Jeff Swiatek, Councilmember
AYES:	Holtz, Jaworowicz, Swiatek, Rogowski, Zydel, Markel, Kaznowski

IV. Suspension of Rules

Motion by Councilmember Markel; Seconded by Councilmember Rogowski to Suspend the Rules to Include the Following Resolution: 2011-115. Motion Carried.
--



1. RESOLUTION 2011-115

Authorize Supervisor to Sign Amendment No. 1 to the General Technical Services Agreement with URS Corporation - New York

Sponsored By: Councilmember Kaznowski, Supervisor Holtz

WHEREAS, by resolution dated May 5, 2008 this Town Board authorized the Supervisor to execute a three (3) year agreement for General Technical Services for calendar years 2008, 2009 and 2010 with URS Corporation - New York, dated May 5, 2008 to assist the Town in performing long term operation and maintenance (O&M) activities at the Pfohl Brothers Landfill site as required under a Settlement Agreement between the Pfohl Brothers Site Steering Committee and the Town consistent with the Operation and Maintenance Plan approved by the New York State Department of Environmental Conservation, AND

WHEREAS, there is a need to continue to perform long term monitoring and operation and maintenance activities at the Pfohl Brothers Landfill Site and the Town Engineer has recommended that the aforesaid three (3) year Technical Services Agreement, which expired on December 31, 2010, be extended in accordance with Amendment No. 1 to the May 5, 2008 General Technical Services Agreement, AND

WHEREAS, Amendment No. 1 provides for the extension of the aforesaid May 5, 2008 Agreement for calendar years 2011, 2012 and 2013, expiring on December 31, 2013, NOW, THEREFORE, BE IT

RESOLVED, that Amendment No. 1 to the General Technical Services Agreement dated May 5, 2008 providing for its extension for three (3) additional calendar years covering 2011, 2012 and 2013 and expiring on December 31, 2013, as recommended by the Town Engineer and reviewed by the Town Attorney, is approved and accepted, AND, BE IT FURTHER

RESOLVED, that the Supervisor is hereby directed and authorized to sign Amendment No. 1 to the General Technical Services Agreement with URS Corporation - New York, 77 Goodell Street, Buffalo, New York 14203, AND, BE IT FURTHER

RESOLVED, that professional service fees shall be chargeable to Account No. 150-1910-5901.

RESULT:	ADOPTED [UNANIMOUS]
MOVER:	Stanley Kaznowski, Councilmember
SECONDER:	Mary Holtz, Supervisor
AYES:	Holtz, Jaworowicz, Swiatek, Rogowski, Zydel, Markel, Kaznowski

V. Communications

A. Departmental Communications

1. Supervisor's Statement of Funds - December 2010
2. Minutes: Cheektowaga Traffic Safety Commission - January 18, 2011

B. General Communications

1. Summons: Chase Home Finance, LLC Vs, Michelle D'Amico, the Town of Cheektowaga & Etal Premises: 43 Hoerner Avenue
2. Notice of Claim: Thomas C. Agen, Jr. Vs. Town of Cheektowaga
3. Notice of Claim: Paul R. Delano, Sr. Vs. Town of Cheektowaga
4. Notice of Claim: Susan M. Koral Vs. Town of Cheektowaga
5. Notice of Claim: Met Life Auto & Home as Subrogee for Mark & Karen Kmiotek Vs. Town of Cheektowaga
6. Notice of Claim: Kevin Park Vs. Town of Cheektowaga
7. Notice of Claim: Patricia Pikuzinski Vs. Town of Cheektowaga
8. Notice of Claim: Angeline Saunders Vs. Town of Cheektowaga
9. Notice of Claim: Dara Tanner Vs. Town of Cheektowaga
10. Notice of Claim: Travelers Insurance as Subrogee for Lynn Francis Vs. Town of Cheektowaga
11. Notice of Claim: Cynthia M. Trippany Vs. Town of Cheektowaga

VI. Comments

A. Supervisor's Comments

B. Councilmember's Comments

C. Public Comments

VII. Adjournment

Motion by Supervisor Holtz; Seconded by Councilmember Swiatek to adjourn the meeting in memory of Sylvia Lipowski, Past Chairman of Cheektowaga Youth Board and Past National Chairman of AMVETS Ladies Auxiliary.



Town of Cheektowaga

Regular Meeting

~ Minutes ~

3301 Broadway
Cheektowaga, NY 14227
<http://www.town.cheektowaga.ny.us>

Alice Magierski
716-686-3400

Monday, March, 7, 2011

6:45 PM

Council Chambers

I. Call to Order

6:45 PM Meeting called to order on March 7, 2011 at Council Chambers, 3301 Broadway St, Cheektowaga, NY.

Attendee Name	Organization	Title	Status	Arrived
Mary Holtz	Town of Cheektowaga	Supervisor	Present	
Patricia Jaworowicz	Town of Cheektowaga	Councilmember	Present	
Jeff Swiatek	Town of Cheektowaga	Councilmember	Late	6:50 PM
James Rogowski	Town of Cheektowaga	Councilmember	Present	
Richard Zydel	Town of Cheektowaga	Councilmember	Present	
Charles Markel	Town of Cheektowaga	Councilmember	Present	
Stanley Kaznowski	Town of Cheektowaga	Councilmember	Present	

2. Additional Attendees

Thomas Adamczak, Supervising Building and Plumbing Inspector
Ellen Fischer, Executive Director - Youth Board
John Jaroszewski, General Crew Chief, Parks Division
Brian Krause, Director of Finance and Administration
John Marriott, Planning Board Chairman
William Pugh, Town Engineer
Anthony Romano, Coordinator of Employee Relations
Kevin Schenk, Town Attorney
Mark Wegner, Highway Superintendent
David Zack, Chief of Police

II. Public Comment Period

III. Public Hearings

1. Amend Parks Ordinance Regarding Dogs in Parks

This being the time and place advertised for a Public Hearing, the Supervisor directed the Town Clerk to present that such notice has been duly published and posted; upon the order of the Supervisor such proof was duly filed.

The Supervisor announced that the Town Board would hear all persons interested in the subject of the hearing. Comments were heard, after which the Supervisor declared the hearing closed, decision was reserved.

RESULT: CLOSED [UNANIMOUS]

MOVER:	Mary Holtz, Supervisor
SECONDER:	James Rogowski, Councilmember
AYES:	Holtz, Jaworowicz, Swiatek, Rogowski, Zydel, Markel, Kaznowski

IV. Resolutions



1. RESOLUTION 2011-117

Transfer of Funds - 2010

Sponsored By: Supervisor Holtz, Councilmember Swiatek

BE IT RESOLVED, that the following transfer is hereby approved and made a part hereof;

2010

GENERAL FUND

FROM: 100.1010.4088	Travel, Training & Conf.	\$	2,269.00
100.1110.1932	Sick Sellback		840.00
100.1110.4001	Office Supplies		1,220.00
100.1110.4013	Law Books		878.00
100.1110.4082	Business Travel		2,189.00
100.1110.4431	Equipment Maint.		86.00
100.1110.4592	Contracted Clerical		1,625.00
100.9010.8141	Employee Medical Ins.		78,963.00
100.1315.2201	Office Equipment		1,200.00
100.1315.4001	Office Supplies		308.00
100.1315.4088	Travel, Training & Conf.		1,826.00
100.1315.4701	Coupon Expense		1,600.00
100.1355.1931	Vacation Sellback		49.00
100.1410.1901	Regular Payroll		1,855.00
100.1410.1931	Vacation Sellback		1,175.00
100.1410.1971	PT Regular		1,336.00
100.1440.4001	Office Supplies		134.00
100.1625.1951	Seasonal Regular		73.00
100.1640.1971	PT Regular		5,695.00
100.1640.2502	Pool Cars		4,876.00
100.1640.4161	Gasoline		4,554.00
100.1670.1911	Longevity		18.00
100.1680.4088	Travel, Training & Conf.		817.00
100.1680.4146	Outsourcing Services		2,750.00
100.1680.4206	Internet Services		3,979.00
100.1680.4434	Software Maint.		1,463.00
100.1680.4437	Pooled Maint. Costs		4,625.00
100.3020.1908	Training		8,386.00
100.3020.1914	Shift Differential		4,584.00
100.3020.2513	Communication Equipment		11,079.00
100.3020.4022	Maintenance Contract		4,079.00
100.3120.1901	Regular Payroll		41,748.00
100.3120.1907	Court Time		67,822.00
100.3120.1908	Training		92,729.00
100.3310.1911	Longevity		2,800.00
100.3310.4217	Utilities		5,777.00
100.3310.4561	Contracted Services		709.00
100.3510.4030	Dog Kennel Supplies		2,348.00
100.3510.4432	Repairs & Maintenance		2,150.00
100.5010.1911	Longevity		1,208.00

	100.5132.4211	Electric Highway	25.00
	100.7110.1901	Regular Payroll	5,139.00
	100.7140.1914	Shift Differential	1,713.00
	100.7140.1990	Other Pay	1,200.00
	100.7140.4491	Special Events	375.00
	100.7620.1911	Longevity	1,371.00
TO:	100.1010.1901	Regular Payroll	\$ 2,269.00
	100.1110.1901	Regular Payroll	15,910.00
	100.1110.1902	Overtime Payroll	5,302.00
	100.1110.1971	PT Regular	3,495.00
	100.1315.1901	Regular Payroll	6,266.00
	100.1315.1902	Overtime Payroll	167.00
	100.1315.1932	Sick Sellback	24.00
	100.1315.1971	PT Regular	2,688.00
	100.1355.1932	Sick Sellback	49.00
	100.1410.1902	Overtime Payroll	1,066.00
	100.1410.1990	Other Pay	3,300.00
	100.1420.1901	Regular Payroll	5,343.00
	100.1430.1901	Regular Payroll	4,336.00
	100.1430.4001	Office Supplies	98.00
	100.1440.1901	Regular Payroll	13,656.00
	100.1440.1902	Overtime Payroll	21,595.00
	100.1440.1932	Sick Sellback	134.00
	100.1625.1932	Sick Sellback	73.00
	100.1640.1901	Regular Payroll	15,125.00
	100.1670.1932	Sick Sellback	18.00
	100.1680.1901	Regular Payroll	7,404.00
	100.1680.1902	Overtime Payroll	16,279.00
	100.1680.1990	Other Pay	1,463.00
	100.1680.2204	Computer Hardware	343.00
	100.3020.1901	Regular Payroll	18,961.00
	100.3020.1902	Overtime Payroll	8,492.00
	100.3020.1932	Sick Sellback	675.00
	100.3120.1902	Overtime Payroll	195,685.00
	100.3120.1917	Clothing Allowance	5,400.00
	100.3120.1990	Other Pay	1,200.00
	100.3120.4091	Ammunition	14.00
	100.3310.1902	Overtime Payroll	6,811.00
	100.3310.1914	Shift Differential	845.00
	100.3310.1971	PT Regular	1,630.00
	100.3510.1901	Regular Payroll	1,386.00
	100.3510.1902	Overtime Payroll	2,059.00
	100.3510.1971	PT Regular	1,053.00
	100.5010.1901	Regular Payroll	1,208.00
	100.5132.4432	Repairs & Maintenance	25.00
	100.7110.1902	Overtime Payroll	5,139.00
	100.7140.1901	Regular Payroll	3,213.00
	100.7140.1932	Sick Sellback	21.00
	100.7140.4999	Credit Card Expense	54.00
	100.7620.1901	Regular Payroll	1,353.00
	100.7620.1932	Sick Sellback	18.00
	<u>RISK RETENTION FUND</u>		
FROM:	101.1710.4101	Insurance Premiums	\$ 20,049.00

	101.1722.4519	Excess Ins.	10,974.00
	101.1936.4703	Judgements & Claims	160,000.00
	101.1932.4703	Judgements & Claims	2,273.00
TO:	101.1710.4525	Work Comp Assessments	\$ 31,004.00
	101.1710.4527	Assessments	157.00
	101.1930.4703	Worker's Comp.	130,107.00
	101.1937.4703	Dental & Vision	\$ 32,028.00

SPECIAL DISTRICTS FUND

FROM:	150.8160.1901	Regular Payroll	\$ 58,312.00
	255.8125.1902	Overtime Payroll	10,448.00
	255.8125.4581	Consulting Engineers	32,671.00
	255.8135.1902	Overtime Payroll	16,805.00
	255.8135.2512	Building Improvements	9,965.00
TO:	150.8160.1971	PT Regular	\$ 16,876.00
	150.8160.8975	Retirement Buyout	40,144.00
	150.8173.4444	Recycling Contractor	1,292.00
	255.8125.1901	Regular Payroll	16,565.00
	255.8125.1932	Sick Sellback	147.00
	255.8125.4217	Utilities	1,170.00
	255.8125.4453	Building Repairs	1,046.00
	255.8125.4543	Contracted Sewer Repairs	24,191.00
	255.8135.1901	Regular Payroll	25,596.00
	255.8135.1932	Sick Sellback	69.00
	255.8135.8151	Social Security	1,105.00

HIGHWAY FUND

FROM:	300.5142.4029	Salt	\$ 410.00
TO:	300.5110.4185	Barricades & Block	\$ 315.00
	300.5130.4462	Parts & Supplies	95.00

PART TOWN FUND

FROM:	800.9010.8141	Medical Ins. Employees	\$ 12,536.00
	800.9010.8143	Medical Ins. Retirees	3,731.00
TO:	800.3620.4191	Misc. Expense	\$ 56.00
	800.3620.4411	Refunds of Permits	40.00
	800.9010.8975	Retirement Buyout	16,171.00

RESULT:	ADOPTED [UNANIMOUS]
MOVER:	Mary Holtz, Supervisor
SECONDER:	Jeff Swiatek, Councilmember
AYES:	Holtz, Jaworowicz, Swiatek, Rogowski, Zydel, Markel, Kaznowski



2. RESOLUTION 2011-118

Transfer of Funds - 2011

Sponsored By: Supervisor Holtz, Councilmember Swiatek

BE IT RESOLVED, that the following transfer is hereby approved and made a part hereof;

2011

GENERAL FUND

FROM:	100.7140.2123	Ice Rentals	\$	448.50
TO:	100.7110.1902	Overtime	\$	448.50

HIGHWAY FUND

FROM:	300.5150.4178	Blacktop Special	\$	45,000.00
	300.5130.4462	Parts & Supplies		50,000.00
	300.5140.4291	Shade Trees		30,000.00
TO:	300.5142.4029	Salt	\$	45,000.00
	300.5142.4029	Salt		80,000.00

RESULT:	ADOPTED [UNANIMOUS]
MOVER:	Mary Holtz, Supervisor
SECONDER:	Jeff Swiatek, Councilmember
AYES:	Holtz, Jaworowicz, Swiatek, Rogowski, Zydel, Markel, Kaznowski



3. RESOLUTION 2011-119

Warrant

Sponsored By: Supervisor Holtz, Councilmember Swiatek

BE IT RESOLVED, that the following Vouchers & Warrants submitted to the Town of Cheektowaga prior to March 4, 2011 are hereby approved and made a part hereof;

GENERAL FUND	\$ 768,845.05
RISK RETENTION FUND	42,045.02
HUD HOUSING REHABILITATION	8,378.00
SPECIAL DISTRICTS FUND	210,820.84
HIGHWAY FUND	217,712.24
CAPITAL FUND	473,448.75
TRUST & AGENCY FUND	16,559.93
HUD CDBG FUND	415.16
PART TOWN FUND	33,386.39
NYS AFFORDABLE HOUSING	825.00
	<u>\$1,772,436.38</u>

RESULT: **ADOPTED [UNANIMOUS]**

MOVER: Mary Holtz, Supervisor

SECONDER: Jeff Swiatek, Councilmember

AYES: Holtz, Jaworowicz, Swiatek, Rogowski, Zydel, Markel, Kaznowski



4. RESOLUTION 2011-120

Call for Hearing - Amendments to Vehicle and Traffic Ordinance

Sponsored By: Councilmember Zydel, Councilmember Markel

BE IT RESOLVED, that a public hearing on proposed amendments to Chapter 235 (formerly Chapter 76) of the Code of the Town of Cheektowaga (Vehicle and Traffic) be held on March 21, 2011 at 6:45 P.M. at the Town Hall, 3301 Broadway, Cheektowaga, New York for the purpose of considering the advisability of adopting said amendments, and the Town Clerk is hereby directed to publish the following Notice of Hearing in the CHEEKTOWAGA BEE on the 10th day of March, 2011, said amendments being set forth in the Notice of Hearing.

NOTICE OF PUBLIC HEARING

TAKE NOTICE that the Town Board of the Town of Cheektowaga, Erie County, New York will hold a public hearing at the Town Hall, 3301 Broadway in said Town of Cheektowaga on March 21, 2011 at 6:45 P.M. to consider the advisability of adopting amendments to Chapter 235 of the Code of the Town of Cheektowaga (Vehicle and Traffic); said proposed amendments being as follows:

ARTICLE V. Schedules, Section 235-49, Schedule X: Parking Prohibited in Designated Locations, shall be amended by deleting therefrom the following:

In accordance with the provisions of §235-34, no person shall park a vehicle at any time upon any of the following described streets or parts of streets:

COMO PARK BOULEVARD - North and south sides: from the east curb line of Union Road to the west curb line of Countryside Lane.

ARTICLE V. Schedules, Section 235-49, Schedule X: Parking Prohibited in Designated Locations, shall be amended by adding thereto the following:

In accordance with the provisions of §235-34, no person shall park a vehicle at any time upon any of the following described streets or parts of streets:

COMO PARK BOULEVARD - north side: from the east curb line of Union Road to a point opposite the west curb line of Countryside Lane.

COMO PARK BOULEVARD - south side: from the east curb line of Union Road to the entrance to John C. Stiglmeier Park.

COMO PARK BOULEVARD - south side: from the west curb line of Countryside Lane to a point 500 feet west of the west curb line of Countryside Lane.

BY ORDER OF THE TOWN BOARD OF THE TOWN OF CHEEKTOWAGA, ERIE COUNTY, NEW YORK.

Dated: March 7, 2011

ALICE MAGIERSKI
Town Clerk

<p>RESULT: ADOPTED [UNANIMOUS] MOVER: Richard Zydel, Councilmember SECONDER: Charles Markel, Councilmember AYES: Holtz, Jaworowicz, Swiatek, Rogowski, Zydel, Markel, Kaznowski</p>



5. RESOLUTION 2011-121

Notice to Bidders - Asbestos Survey for 27 Alpine Place

Sponsored By: Councilmember Markel, Councilmember Kaznowski

WHEREAS, pursuant to the Town's Unsafe Buildings Law, Nussbaumer & Clarke, Inc., a duly authorized agent of the Town of Cheektowaga, issued a written report stating that the residential structure located at 27 Alpine Place is unsafe and recommended that such building be demolished; and

WHEREAS, the owner(s) and lienholders of such property were notified to demolish such property, and no action on this demolition has been taken to date; and

WHEREAS, a hearing was held in front of this Board on the 7th day of February, 2011, concerning said unsafe building and the requested demolition; and

WHEREAS, the Town of Cheektowaga needs to take action to demolish this structure in the event the owner of same does not do so; and

WHEREAS, prior to demolition of this property, the Town needs to have an asbestos survey done to determine whether there is asbestos in the structure; and

WHEREAS, Nussbaumer & Clarke, Inc. prepared a Notice to Bidders for this matter; NOW, THEREFORE, BE IT

RESOLVED, that this Town Board hereby approves the Notice to Bidders for the asbestos survey, etc. for 27 Alpine Place; and BE IT FURTHER

RESOLVED, that the Town Clerk's Office be and hereby is directed to publish the attached Notice to Bidders in the CHEEKTOWAGA BEE; and BE IT FURTHER

RESOLVED, that bids for the Asbestos Survey, Specifications and Air Monitoring Services for 27 Alpine Place shall be due no later than March 16, 2011 at 11:00 A.M. at the Town Clerk's Office, and BE IT FURTHER

RESOLVED, that the Town Clerk be and hereby is appointed as the officer to open the proposals in the Council Chambers of the Town Hall on March 16, 2011 at 11:00 a.m.

NOTICE TO BIDDERS FOR ASBESTOS SURVEY, SPECIFICATIONS & AIR MONITORING SERVICES FOR PROPERTY LOCATED AT 27 ALPINE PLACE, CHEEKTOWAGA, NEW YORK

NOTICE IS HEREBY GIVEN that the Town of Cheektowaga is seeking proposals from qualified contractors to prepare an asbestos survey for property located at 27 Alpine Place, Cheektowaga, New York. The contractor shall also submit quotes for Asbestos specifications for the demolition and air monitoring services during demolition if asbestos is found in this dwelling.

Sealed proposals will be received and considered by the Town Board of the Town of

Cheektowaga on March 16, 2011 at 11:00 A.M. at the Town Hall, 3301 Broadway, Cheektowaga, New York for said services.

Information to Bidders and Specifications may be obtained from the Town Clerk at her office in said Town Hall.

The Town Board reserves the right to consider informal any proposal not prepared and submitted in accordance with the specifications, and may waive informalities and make an award to the vendor who, in its opinion, offers the best deal for the Town.

BY ORDER OF THE TOWN BOARD OF THE TOWN OF CHEEKTOWAGA, ERIE COUNTY, NEW YORK.

Dated: March 7, 2011

ALICE MAGIERSKI
Town Clerk

RESULT:	ADOPTED [UNANIMOUS]
MOVER:	Charles Markel, Councilmember
SECONDER:	Stanley Kaznowski, Councilmember
AYES:	Holtz, Jaworowicz, Swiatek, Rogowski, Zydel, Markel, Kaznowski



6. RESOLUTION 2011-122

Notice to Bidders - Asbestos Survey for 89 Gardenvale Drive

Sponsored By: Councilmember Markel, Councilmember Kaznowski

WHEREAS, pursuant to the Town's Unsafe Buildings Law, Nussbaumer & Clarke, Inc., a duly authorized agent of the Town of Cheektowaga, issued a written report stating that the residential structure located at 89 Gardenvale Drive is unsafe and recommended that such building be demolished; and

WHEREAS, the owner(s) and lienholders of such property were notified to demolish such property, and no action on this demolition has been taken to date; and

WHEREAS, a hearing was held in front of this Board on the 7th day of February, 2011, concerning said unsafe building and the requested demolition; and

WHEREAS, the Town of Cheektowaga needs to take action to demolish this structure in the event the owner of same does not do so; and

WHEREAS, prior to demolition of this property, the Town needs to have an asbestos survey done to determine whether there is asbestos in the structure; and

WHEREAS, Nussbaumer & Clarke, Inc. prepared a Notice to Bidders for this matter; NOW, THEREFORE, BE IT

RESOLVED, that this Town Board hereby approves the Notice to Bidders for the asbestos survey, etc. for 89 Gardenvale Drive; and BE IT FURTHER

RESOLVED, that the Town Clerk's Office be and hereby is directed to publish the attached Notice to Bidders in the CHEEKTOWAGA BEE; and BE IT FURTHER

RESOLVED, that bids for the Asbestos Survey, Specifications and Air Monitoring Services for 89 Gardenvale Drive shall be due no later than March 16, 2011 at 11:00 A.M. at the Town Clerk's Office, and BE IT FURTHER

RESOLVED, that the Town Clerk be and hereby is appointed as the officer to open the proposals in the Council Chambers of the Town Hall on March 16, 2011 at 11:00 a.m.

NOTICE TO BIDDERS FOR ASBESTOS SURVEY, SPECIFICATIONS & AIR MONITORING SERVICES FOR PROPERTY LOCATED AT 89 GARDENVALE DRIVE, CHEEKTOWAGA, NEW YORK

NOTICE IS HEREBY GIVEN that the Town of Cheektowaga is seeking proposals from qualified contractors to prepare an asbestos survey for property located at 89 Gardenvale Drive, Cheektowaga, New York. The contractor shall also submit quotes for Asbestos specifications for the demolition and air monitoring services during demolition if asbestos is found in this dwelling.

Sealed proposals will be received and considered by the Town Board of the Town of

Cheektowaga on March 16, 2011 at 11:00 A.M. at the Town Hall, 3301 Broadway, Cheektowaga, New York for said services.

Information to Bidders and Specifications may be obtained from the Town Clerk at her office in said Town Hall.

The Town Board reserves the right to consider informal any proposal not prepared and submitted in accordance with the specifications, and may waive informalities and make an award to the vendor who, in its opinion, offers the best deal for the Town.

BY ORDER OF THE TOWN BOARD OF THE TOWN OF CHEEKTOWAGA, ERIE COUNTY, NEW YORK.

Dated: March 7, 2011

ALICE MAGIERSKI
Town Clerk

RESULT:	ADOPTED [UNANIMOUS]
MOVER:	Charles Markel, Councilmember
SECONDER:	Stanley Kaznowski, Councilmember
AYES:	Holtz, Jaworowicz, Swiatek, Rogowski, Zydel, Markel, Kaznowski



7. RESOLUTION 2011-123

Notice to Bidders - Asbestos Survey for 24E Glenwood Court

Sponsored By: Councilmember Markel, Councilmember Kaznowski

WHEREAS, pursuant to the Town's Unsafe Buildings Law, Nussbaumer & Clarke, Inc., a duly authorized agent of the Town of Cheektowaga, issued a written report stating that the residential structure located at 24E Glenwood Court is unsafe and recommended that such building be demolished; and

WHEREAS, the owner(s) and lienholders of such property were notified to demolish such property, and no action on this demolition has been taken to date, and

WHEREAS, a hearing was held in front of this Board on the 7th day of February, 2011, concerning said unsafe building and the requested demolition; and

WHEREAS, the Town of Cheektowaga needs to take action to demolish this structure in the event the owner of same does not do so; and

WHEREAS, prior to demolition of this property, the Town needs to have an asbestos survey done to determine whether there is asbestos in the structure; and

WHEREAS, Nussbaumer & Clarke, Inc. prepared a Notice to Bidders for this matter; NOW, THEREFORE, BE IT

RESOLVED, that this Town Board hereby approves the Notice to Bidders for the asbestos survey, etc. for 24E Glenwood Court; and BE IT FURTHER

RESOLVED, that the Town Clerk's Office be and hereby is directed to publish the attached Notice to Bidders in the CHEEKTOWAGA BEE; and BE IT FURTHER

RESOLVED, that bids for the Asbestos Survey, Specifications and Air Monitoring Services for 24E Glenwood Court shall be due no later than March 16, 2011 at 11:00 A.M. at the Town Clerk's Office, and BE IT FURTHER

RESOLVED, that the Town Clerk be and hereby is appointed as the officer to open the proposals in the Council Chambers of the Town Hall on March 16, 2011 at 11:00 a.m.

NOTICE TO BIDDERS FOR ASBESTOS SURVEY, SPECIFICATIONS & AIR MONITORING SERVICES FOR PROPERTY LOCATED AT 24E GLENWOOD COURT, CHEEKTOWAGA, NEW YORK

NOTICE IS HEREBY GIVEN that the Town of Cheektowaga is seeking proposals from qualified contractors to prepare an asbestos survey for property located at 24E Glenwood Court, Cheektowaga, New York. The contractor shall also submit quotes for Asbestos specifications for the demolition and air monitoring services during demolition if asbestos is found in this dwelling.

Sealed proposals will be received and considered by the Town Board of the Town of

Cheektowaga on March 16, 2011 at 11:00 A.M. at the Town Hall, 3301 Broadway, Cheektowaga, New York for said services.

Information to Bidders and Specifications may be obtained from the Town Clerk at her office in said Town Hall.

The Town Board reserves the right to consider informal any proposal not prepared and submitted in accordance with the specifications, and may waive informalities and make an award to the vendor who, in its opinion, offers the best deal for the Town.

BY ORDER OF THE TOWN BOARD OF THE TOWN OF CHEEKTOWAGA, ERIE COUNTY, NEW YORK.

Dated: March 7, 2011

ALICE MAGIERSKI
Town Clerk

RESULT:	ADOPTED [UNANIMOUS]
MOVER:	Charles Markel, Councilmember
SECONDER:	Stanley Kaznowski, Councilmember
AYES:	Holtz, Jaworowicz, Swiatek, Rogowski, Zydel, Markel, Kaznowski



8. RESOLUTION 2011-124

Award of Bid - Preventative Maintenance

Sponsored By: Councilmember Kaznowski, Councilmember Zydel

WHEREAS, a regularly scheduled maintenance program for Town owned emergency generator systems is required to ensure proper operation during an emergency, AND

WHEREAS, the Town Engineering Department has solicited quotations from various vendors to fulfill an annual Preventative Maintenance Program for the 2011 and 2012 calendar years for all Town owned emergency generator systems located at various Town owned facilities including the Town Hall, Police Department, Senior Citizens Center, Highway Department, Central Garage and various sewer district facilities, NOW, THEREFORE, BE IT

RESOLVED, that the contract for Preventative Maintenance be awarded to R. B. U'Ren Equipment, Inc., 1120 Connecting Road, Niagara Falls, New York 14304 for their submission of the lowest proposal in the amount of \$3,924.93 for 2011 and \$3,924.93 for 2012, AND, BE IT FURTHER

RESOLVED, that \$1,970.37 (2011) and \$1,970.37 (2012) shall be chargeable to the Facilities Department Account #100-1625-4432 and \$1,642.87 (2011) and \$1,642.87 (2012) shall be chargeable to the Sewer Maintenance Department Account #2550-8125-4431 and \$311.69 (2011) and \$311.69 (2012) shall be chargeable to the Highway Department Account #100-5132-4432.

RESULT:	ADOPTED [UNANIMOUS]
MOVER:	Stanley Kaznowski, Councilmember
SECONDER:	Richard Zydel, Councilmember
AYES:	Holtz, Jaworowicz, Swiatek, Rogowski, Zydel, Markel, Kaznowski



9. RESOLUTION 2011-125

Award of Bid - Police Interceptor Vehicles

Sponsored By: Councilmember Jaworowicz, Councilmember Rogowski

WHEREAS, bids were duly received by the Town Clerk at a bid opening on February 23, 2011, for the purchase of six (6) new and unused 2011 Ford Crown Victoria Police Interceptors by the Town of Cheektowaga Police Department, and said bids were referred to the Cheektowaga Police Department for analysis, tabulation and report; AND

WHEREAS, such analysis, tabulation and report has been completed, NOW, THEREFORE, BE IT

RESOLVED, that the bid for the purchase of said vehicles be awarded to Towne Ford, 3535 Southwestern Boulevard, Orchard Park, New York, 14227 for the purchase price of \$129,738.00, said bid being the lowest responsible bid meeting all specifications; AND, BE IT FURTHER

RESOLVED, that funds for the purchase of these vehicles shall be appropriated from line item number #100-3120-2303.

RESULT:	ADOPTED [UNANIMOUS]
MOVER:	Patricia Jaworowicz, Councilmember
SECONDER:	James Rogowski, Councilmember
AYES:	Holtz, Jaworowicz, Swiatek, Rogowski, Zydel, Markel, Kaznowski



10. RESOLUTION 2011-126

Approve Purchase of Ammunition

Sponsored By: Councilmember Jaworowicz, Councilmember Rogowski

WHEREAS, the Cheektowaga Police Department is requesting to purchase various rounds of ammunition under New York State OGS Contract PC63287, AND

WHEREAS, Eagle Point Gun/T. J. Morris & Son is listed as an approved New York State contractor/provider of ammunition, AND

WHEREAS, funds for said purchase have been budgeted and are available from account number 100-3120-4091, NOW, THEREFORE, BE IT

RESOLVED, that the Town Board hereby authorizes the purchase of ammunition in the amount of \$17,421.24 from:

Eagle Point Gun/T. J. Morris & Son
1707 Third Street
Thorofare, New Jersey 08086

RESULT:	ADOPTED [UNANIMOUS]
MOVER:	Patricia Jaworowicz, Councilmember
SECONDER:	James Rogowski, Councilmember
AYES:	Holtz, Jaworowicz, Swiatek, Rogowski, Zydel, Markel, Kaznowski



11. RESOLUTION 2011-127

Approve Purchase of Three (3) Trucks

Sponsored By: Councilmember Swiatek, Supervisor Holtz

WHEREAS, the Highway Department has requested authorization to purchase three (3) 2011 Ford F-450 4x4 Regular Cab trucks, as specified in New York State OGS Contract PC63652, AND

WHEREAS, funds for said purchase have been budgeted and are available under account number 300-5130-2407, NOW, THEREFORE BE IT,

RESOLVED, that the Town Board hereby authorizes the purchase of three (3) 2011 Ford F-450 4x4 Regular Cab Truck, in the amount of \$132,053.58 from:

Van Bortel Ford
71 Marsh Road
E. Rochester, NY 14445

RESULT:	ADOPTED [UNANIMOUS]
MOVER:	Jeff Swiatek, Councilmember
SECONDER:	Mary Holtz, Supervisor
AYES:	Holtz, Jaworowicz, Swiatek, Rogowski, Zydel, Markel, Kaznowski



12. RESOLUTION 2011-128

Approve Purchase of Two (2) Trucks New & Unused 2012 Kenworth T800 Plow Truck

Sponsored By: Councilmember Swiatek, Supervisor Holtz

WHEREAS, the Highway Department has requested authorization to purchase two (2) New & Unused 2012 Kenworth T800 Plow Truck, as specified in Erie County Bid, Reference Bid #200215-004, Requisition #10027136, AND

WHEREAS, funds for said purchase have been budgeted and are available under account number 300-5130-2407, NOW, THEREFORE BE IT,

RESOLVED, that the Town Board hereby authorizes the purchase of two (2) 2012 Kenworth T800 Plow Truck, in the amount of \$238,420.00 from:

Kenworth of Buffalo
100 Commerce Drive
Lackawanna, NY 14218

RESULT:	ADOPTED [UNANIMOUS]
MOVER:	Jeff Swiatek, Councilmember
SECONDER:	Mary Holtz, Supervisor
AYES:	Holtz, Jaworowicz, Swiatek, Rogowski, Zydel, Markel, Kaznowski



13. RESOLUTION 2011-129

Change Order No. 1 (Final) HVAC Work at the Anna Reinstein Memorial Library

Sponsored By: Councilmember Rogowski, Supervisor Holtz

WHEREAS, the contract for HVAC Work at the Anna Reinstein Memorial Library was awarded by Town Board Resolution dated October 19, 2009 to Tri-R Mechanical Services in the amount of \$288,515.00, AND

WHEREAS, Trautman Associates, Project Architect, and the Town Engineer have advised that work under the aforesaid contract has been completed in accordance with the contract requirements and further recommends the approval of Change Order No. 1 (final) which provides for an addition to the contract as further outlined in the Change Order Document, NOW, THEREFORE, BE IT

RESOLVED, that this Town Board hereby accepts the completed project and directs the Supervisor to execute the final contract acceptance documents with Tri-R Mechanical Services, 25 Ransier Drive, West Seneca, New York 14224, including Change Order No. 1 (final) which provides for an addition to the aforesaid contract in the amount of \$584.00.

RESULT:	ADOPTED [UNANIMOUS]
MOVER:	James Rogowski, Councilmember
SECONDER:	Mary Holtz, Supervisor
AYES:	Holtz, Jaworowicz, Swiatek, Rogowski, Zydel, Markel, Kaznowski



14. RESOLUTION 2011-130

Home Rule Request Concerning Diamond Hawk Golf Course

Sponsored By: Supervisor Holtz, Councilmember Rogowski

WHEREAS, by Chapter 455 of the Laws of 2001, the State Legislature and Governor approved legislation authorizing the Town to enter into a 30-year lease with Garrett, LLC for Town parkland now known as the Diamond Hawk Golf Course, and

WHEREAS, by resolution dated March 18, 2002, the Cheektowaga Town Board agreed to enter into a 30-year lease with Garrett, LLC for said golf course lands, and

WHEREAS, Section 3.6 of said lease requires the Town of Cheektowaga to apply to the State to extend the term of said lease, and'

WHEREAS, the lessee of the golf course lands has requested this Town Board to request the State Legislature to authorize this Town Board to so extend the lease, and

WHEREAS, by prior resolutions (Resolution Nos. 2007-387 and 2008-78, 2009-84), the Cheektowaga Town Board made Home Rule Requests to the State Senate and Assembly to enact Assembly and Senate Bills to authorize the extension of the lease, and

WHEREAS, said Home Rule Request bills died since the Bills had not yet been enacted, and

WHEREAS, bills have been re-introduced in the State Assembly (A.2583) and Senate (S.3330) to authorize the Town to lease these parklands to Garrett, LLC for an additional ten (10) years for the Diamond Hawk golf course, NOW, THEREFORE, BE IT

RESOLVED, that this Town Board hereby requests the State Assembly and Senate to enact Assembly Bill A.2583 and Senate Bill S.3330, and BE IT FURTHER

RESOLVED, that the Town Clerk be and hereby is directed to execute the Home Rule Request forms for the aforementioned Assembly and Senate bills, and to forward same to the Home Rule Counsels for the Assembly and Senate, with copies to Assemblyman Dennis H. Gabryszak and Senator Timothy M. Kennedy.

RESULT:	ADOPTED [UNANIMOUS]
MOVER:	Mary Holtz, Supervisor
SECONDER:	James Rogowski, Councilmember
AYES:	Holtz, Jaworowicz, Swiatek, Rogowski, Zydel, Markel, Kaznowski



15. RESOLUTION 2011-131

Authorize Supervisor to Execute Amended Easement Agreement with Erie County

Sponsored By: Councilmember Rogowski, Councilmember Kaznowski

WHEREAS, pursuant to resolution dated February 6, 2006 (Resolution 2006-83), the Town of Cheektowaga entered into an Easement Agreement dated October 7, 2007 with the County of Erie relating to the use of a portion of Como Park Boulevard for the Rails-to-Trails bike path project, and

WHEREAS, part of said easement agreement required the Town to prohibit the parking of vehicles in the right of way on the north and south sides of Como Park Boulevard, from Union Road to Countryside Lane, and

WHEREAS, many people access Stiglmeier Park from the back entrance on Como Park Boulevard and have nowhere to park their vehicles, and

WHEREAS, the Rails-to-Trails bike path along Como Park Boulevard technically is only located between Union Road and the back entrance to Stiglmeier Park; as such, parking on the south side of Como Park Boulevard east of the back entrance to Stiglmeier Park would not interfere with the users of the bike path, and

WHEREAS, the Town of Cheektowaga has requested the County of Erie to amend the aforesaid Easement Agreement to permit parking on the south side of Como Park Boulevard east of the back entrance to Stiglmeier Park, and the County of Erie has consented to same, and

WHEREAS, the Town Attorney has drafted an Amendment to Easement Agreement which has been approved by the Erie County Commissioner of Public Works, NOW, THEREFORE, BE IT

RESOLVED, that the Supervisor be and hereby is authorized and directed to execute the aforementioned Amendment to Easement Agreement with the County of Erie.

RESULT:	ADOPTED [UNANIMOUS]
MOVER:	James Rogowski, Councilmember
SECONDER:	Stanley Kaznowski, Councilmember
AYES:	Holtz, Jaworowicz, Swiatek, Rogowski, Zydel, Markel, Kaznowski



16. RESOLUTION 2011-132

Authorize Supervisor to Sign Agreement with Wilmac Company for Purchase of 9-1-1 Police Dispatch Recording System

Sponsored By: Councilmember Jaworowicz, Councilmember Rogowski

WHEREAS, the current audio 9-1-1 recording system in the Cheektowaga Police Department is no longer supported and has reached the end of its life, AND

WHEREAS, Wilmac Company has submitted a proposal to provide a 9-1-1 Call Recording System that will handle emergency calls received in the Police Dispatch area, as well as NICE Inform Lite system software, professional on-site installation, training and Gold Annual Maintenance, AND

WHEREAS, Wilmac Company is a New York State approved contract provider and their New York State Contract Number is PT65096, AND

WHEREAS, total cost for the project is \$25,717.00, AND

WHEREAS, money has been budgeted for said expenditure out of Account # 100-3020-2513, NOW, THEREFORE, BE IT

RESOLVED, that the Town Supervisor is directed and authorized to sign said agreement with Wilmac Company, 73 State Street, Rochester, New York 14614 for \$25,717.00, AND, BE IT FURTHER

RESOLVED, that this agreement is subject to approval by the Town Attorney.

RESULT:	ADOPTED [UNANIMOUS]
MOVER:	Patricia Jaworowicz, Councilmember
SECONDER:	James Rogowski, Councilmember
AYES:	Holtz, Jaworowicz, Swiatek, Rogowski, Zydel, Markel, Kaznowski



17. RESOLUTION 2011-133

Hiring/Termination of Part-Time/Seasonal Employees

Sponsored By: Councilmember Swiatek, Supervisor Holtz

BE IT RESOLVED, that the following individual be and hereby is hired as a **PART-TIME EMPLOYEE** in the department listed, not to exceed nineteen (19) hours on a weekly basis, in compliance with Civil Service Laws and Regulations as well as the provisions of the Town's collective bargaining agreement between the Town of Cheektowaga and the Town of Cheektowaga Employees Association:

FACILITIES DEPARTMENT (Parks Division) Laborer \$8.25/hour effective 2/28/11
Joseph Galletta, Cheektowaga, New York

Motion by Supervisor Holtz; Seconded by Councilmember Rogowski to waive the reading of name for this resolution.

RESULT: ADOPTED [UNANIMOUS]
MOVER: Jeff Swiatek, Councilmember
SECONDER: Mary Holtz, Supervisor
AYES: Holtz, Jaworowicz, Swiatek, Rogowski, Zydel, Markel, Kaznowski



18. RESOLUTION 2011-134

Police Chief David J. Zack - Employment Benefits

Sponsored By: Councilmember Jaworowicz, Councilmember Swiatek

WHEREAS, by resolution dated February 23, 2011 (Resolution 2011-105), David J. Zack was appointed to the position of Police Chief effective February 26, 2011; AND

WHEREAS, the previous incumbent of the aforementioned title received stipulated employment benefits as outlined in the collective bargaining agreement between the Town of Cheektowaga and the Town of Cheektowaga Captains and Lieutenants Association; AND

WHEREAS, Section 207-m of the General Municipal Law of the State of New York requires the Police Chief be provided the same benefits as those provided to Police Captains; NOW, THEREFORE, BE IT

RESOLVED, that the Police Chief shall continue to receive the stipulated employment benefits outlined in the following sections of the collective bargaining agreement between the Town of Cheektowaga and the Town of Cheektowaga Captains and Lieutenants Association effective February 26, 2011 until modified by the Town Board:

- Section 04.01 Uniform Maintenance Allowance
- Section 06.07 Longevity Pay
- Section 06.08 Redemption of Accumulated Time
- Section 06.09 Education Incentive Pay
- Section 06.11 Off-Duty Authority
- Section 06.12 Jury Duty Pay
- Section 09.01 Holidays
- Section 10.01 Vacations
- Section 10.02 Unused Benefits
- Section 10.03 Vacation Pay Advance
- Section 10.04 Redemption of Time upon Retirement or Separation from Employment
- Section 11.01 Bereavement Leave
- Section 12.01 Personal Leave
- Section 13.01 Sick Leave
- Section 13.05 Work-Related Disability
- Section 13.06 Sick Leave upon Termination
- Section 14.01 Expenses
- Section 15.01 Life Insurance
- Section 15.02 Health Insurance
- Section 15.03 Indemnification
- Section 16.01 Retirement Benefits
- Section 19.02 Tuition

RESULT:	ADOPTED [UNANIMOUS]
MOVER:	Patricia Jaworowicz, Councilmember
SECONDER:	Jeff Swiatek, Councilmember

AYES: Holtz, Jaworowicz, Swiatek, Rogowski, Zydel, Markel, Kaznowski



19. RESOLUTION 2011-135

Appointment of Senior Sewer Maintenance Worker (Non-Competitive/Permanent) Sewer Maintenance/Gary L. Podgorski

Sponsored By: Councilmember Swiatek, Supervisor Holtz

WHEREAS, Gary L. Podgorski was appointed by this Town Board to the position of Sewer Maintenance Worker effective August 18, 2009; AND

WHEREAS, Mr. Podgorski has successfully completed eighteen (18) months in the title and is eligible to be promoted to the position of Senior Sewer Maintenance Worker; NOW, THEREFORE, BE IT

RESOLVED, that Gary L. Podgorski of Cheektowaga, New York be and hereby is appointed to the position of Senior Sewer Maintenance Worker in the Sewer Maintenance Division under the terms and conditions of the bargaining agreement between the Town and the Town of Cheektowaga Employees Association effective February 18, 2011.

RESULT:	ADOPTED [UNANIMOUS]
MOVER:	Jeff Swiatek, Councilmember
SECONDER:	Mary Holtz, Supervisor
AYES:	Holtz, Jaworowicz, Swiatek, Rogowski, Zydel, Markel, Kaznowski

**20. RESOLUTION 2011-136****Travel Authorization (Police Department) Police Officers
Michael McDonough and Scott Scharlau**

Sponsored By: Councilmember Jaworowicz, Councilmember Swiatek

WHEREAS, the New York State Truck Safety and Education Symposium and Safety Exhibition is being held March 22 through March 23, 2011 in Albany, New York; AND

WHEREAS, Police Officers Michael McDonough and Scott Scharlau have requested authorization to attend said exhibition; AND

WHEREAS, Police Chief David Zack has submitted a request for travel authorization along with the proper paperwork in a timely manner; AND

WHEREAS, the total cost to the Town shall not exceed \$781; AND

WHEREAS, these expenses have been budgeted by the Police Department; NOW, THEREFORE, BE IT

RESOLVED, that Police Officers Michael McDonough and Scott Scharlau be and hereby are authorized to attend the New York State Truck Safety and Education Symposium and Safety Exhibition being held March 22 through March 23, 2011 in Albany, New York.

RESULT:	ADOPTED [UNANIMOUS]
MOVER:	Patricia Jaworowicz, Councilmember
SECONDER:	Jeff Swiatek, Councilmember
AYES:	Holtz, Jaworowicz, Swiatek, Rogowski, Zydel, Markel, Kaznowski



21. RESOLUTION 2011-137

Travel Authorization (Police Department) Captain Michael Isbrandt, Lieutenants Thomas Wentland and Kenneth Rusin

Sponsored By: Councilmember Jaworowicz, Councilmember Swiatek

WHEREAS, the "Practical Homicide Investigation" seminar is being held March 28 through March 30, 2011 in Amherst, New York; AND

WHEREAS, Captain Michael Isbrandt and Lieutenants Thomas Wentland and Kenneth Rusin have requested authorization to attend said seminar; AND

WHEREAS, Police Chief David Zack has submitted a request for travel authorization along with the proper paperwork in a timely manner; AND

WHEREAS, the total cost to the Town shall not exceed \$1,422; AND

WHEREAS, these expenses have been budgeted by the Police Department; NOW, THEREFORE, BE IT

RESOLVED, that Captain Michael Isbrandt and Lieutenants Thomas Wentland and Kenneth Rusin be and hereby are authorized to attend the "Practical Homicide Investigation" seminar being held March 28 through March 30, 2011 in Amherst, New York.

RESULT:	ADOPTED [UNANIMOUS]
MOVER:	Patricia Jaworowicz, Councilmember
SECONDER:	Jeff Swiatek, Councilmember
AYES:	Holtz, Jaworowicz, Swiatek, Rogowski, Zydel, Markel, Kaznowski

V. Communications

A. Departmental Communications

1. Building Permit List - February 2011
2. Minutes: Town Environmental Advisory Committee - February 9, 2011
3. Minutes: Cheektowaga Traffic Safety Commission - February 15, 2011
4. Minutes: Cheektowaga Public Library - Board of Trustees - February 16, 2011

B. General Communications

1. Summons: Wells Fargo Bank, NA Vs. Stephen J. Zawadzki, Mary Lou Zawadzki & Town of Cheektowaga Premises: 82 Wanda Avenue

2. Notice of Claim: Allstate Insurance Co. as Subrogee of Frank & Judy Blajszczak Vs. Town of Cheektowaga
3. Notice of Claim: Betty J. Dubose Vs. Town of Cheektowaga
4. Notice of Claim: Ashley Lyn Malczewski Vs. Town of Cheektowaga

VI. Comments

A. Supervisor's Comments

B. Councilmember's Comments

C. Public Comments

VII. Adjournment

Motion by Supervisor Holtz; Seconded by Councilmember Kaznowski to adjourn the meeting in Memory of Arthur Blachowski, - Retiree of the Town of Cheektowaga, Sign Maintenance Division, Fire Commissioner and Life Member of Hy-View Fire Company District #8.

Alice Magierski

Town Clerk



Town of Cheektowaga

Work Session

~ Minutes ~

3301 Broadway
Cheektowaga, NY 14227

<http://www.town.cheektowaga.ny.us>

Alice Magierski
716-686-3400

Tuesday, March, 15, 2011

6:00 PM

Council Office

I. Call to Order

6:00 PM Meeting called to order on March 15, 2011 at Council Office, Conference Room, Cheektowaga, NY.

Attendee Name	Organization	Title	Status	Arrived
Mary Holtz	Town of Cheektowaga	Supervisor	Present	
Patricia Jaworowicz	Town of Cheektowaga	Councilmember	Absent	
Jeff Swiatek	Town of Cheektowaga	Councilmember	Present	
James Rogowski	Town of Cheektowaga	Councilmember	Present	
Richard Zydel	Town of Cheektowaga	Councilmember	Present	
Charles Markel	Town of Cheektowaga	Councilmember	Present	
Stanley Kaznowski	Town of Cheektowaga	Councilmember	Present	

II. Resolutions



1. RESOLUTION 2011-138

Settlement of Litigation - B-D Assurance Vs. Town

Sponsored By: Councilmember Swiatek, Supervisor Holtz

WHEREAS, B-D Assurance Co., Ltd./Sperian Protective Gloves USA LLC commenced an Article 7 proceeding against the Town for Tax Year 2010-2011 seeking a reduction in the assessment of properties owned by it located at 85 Innsbruck Drive (S.B.L. Nos. 124.00-6-8.1 and 124.00-6-8.2) in Cheektowaga, New York; and

WHEREAS, the Town's outside Attorney consultant and the Town Assessor have reviewed the petitions and, after due consideration of all materials facts, and after negotiations with the petitioner's attorney, believe it is in the best interest of the Town to resolve this matter without further litigation and strongly recommend the proposed compromise; NOW THEREFORE, BE IT

RESOLVED, that the Town Board approves the above compromise and settlement, and the Town's outside Attorney consultant and Town Assessor be and hereby are authorized to execute and procure all papers necessary to effectuate the settlement of said Article 7 proceedings.

RESULT:	ADOPTED [UNANIMOUS]
MOVER:	Jeff Swiatek, Councilmember
SECONDER:	Mary Holtz, Supervisor
AYES:	Holtz, Swiatek, Rogowski, Zydell, Markel, Kaznowski
ABSENT:	Patricia Jaworowicz



2. RESOLUTION 2011-139

Settlement of Litigation - Boden, LLC Vs. Town

Sponsored By: Supervisor Holtz, Councilmember Swiatek

WHEREAS, Boden, LLC commenced an Article 7 proceeding against the Town for Tax Year 2010-2011 seeking a reduction in the assessment of property owned by it located at 2585 Walden Avenue in Cheektowaga, New York; and

WHEREAS, the Town's outside Attorney consultant and the Town Assessor have reviewed the petitions and, after due consideration of all materials facts, and after negotiations with the petitioner's attorney, believe it is in the best interest of the Town to resolve this matter without further litigation and strongly recommend the proposed compromise; NOW THEREFORE, BE IT

RESOLVED, that the Town Board approves the above compromise and settlement, and the Town's outside Attorney consultant and Town Assessor be and hereby are authorized to execute and procure all papers necessary to effectuate the settlement of said Article 7 proceedings.

RESULT:	ADOPTED [UNANIMOUS]
MOVER:	Mary Holtz, Supervisor
SECONDER:	Jeff Swiatek, Councilmember
AYES:	Holtz, Swiatek, Rogowski, Zydel, Markel, Kaznowski
ABSENT:	Patricia Jaworowicz



3. RESOLUTION 2011-140

Settlement of Litigation - Walden Princeton Vs. Town

Sponsored By: Councilmember Swiatek, Supervisor Holtz

WHEREAS, Walden Princeton, LLC commenced an Article 7 proceeding against the Town for Tax Years 2009-2010 and 2010-2011 seeking a reduction in the assessment of properties owned by it located at 55, 59 and 63 Princeton Avenue; and 3206, 3208 and 3210 Walden Avenue in Cheektowaga, New York; and

WHEREAS, the Town's outside Attorney consultant and the Town Assessor have reviewed the petitions and, after due consideration of all materials facts, and after negotiations with the petitioner's attorney, believe it is in the best interest of the Town to resolve this matter without further litigation and strongly recommend the proposed compromise; NOW THEREFORE, BE IT

RESOLVED, that the Town Board approves the above compromise and settlement, and the Town's outside Attorney consultant and Town Assessor be and hereby are authorized to execute and procure all papers necessary to effectuate the settlement of said Article 7 proceedings.

RESULT:	ADOPTED [UNANIMOUS]
MOVER:	Jeff Swiatek, Councilmember
SECONDER:	Mary Holtz, Supervisor
AYES:	Holtz, Swiatek, Rogowski, Zydell, Markel, Kaznowski
ABSENT:	Patricia Jaworowicz



Town of Cheektowaga

Regular Meeting

~ Minutes ~

3301 Broadway
Cheektowaga, NY 14227
<http://www.town.cheektowaga.ny.us>

Alice Magierski
716-686-3400

Monday, March 21, 2011

6:45 PM

Council Chambers

I. Call to Order

6:45 PM Meeting called to order on March 21, 2011 at Council Chambers, 3301 Broadway St, Cheektowaga, NY.

Attendee Name	Organization	Title	Status	Arrived
Mary Holtz	Town of Cheektowaga	Supervisor	Present	
Patricia Jaworowicz	Town of Cheektowaga	Councilmember	Present	
Jeff Swiatek	Town of Cheektowaga	Councilmember	Present	
James Rogowski	Town of Cheektowaga	Councilmember	Present	
Richard Zydel	Town of Cheektowaga	Councilmember	Present	
Charles Markel	Town of Cheektowaga	Councilmember	Present	
Stanley Kaznowski	Town of Cheektowaga	Councilmember	Present	

2. Additional Attendees

Thomas Adamczak, Supervising Building and Plumbing Inspector
 Patrick Bowen, Engineering Office
 Ellen Fischer, Executive Director - Youth Board
 Jerry Gabryszak, Director of Community Development
 John Marriott, Planning Board Chairman
 Kevin Schenk, Town Attorney
 David Zack, Chief of Police

II. Public Comment Period

III. Public Hearing

1. Amendments to Vehicle and Traffic Ordinance

This being the time and place advertised for a Public Hearing, the Supervisor directed the Town Clerk to present that such notice has been duly published and posted; upon the order of the Supervisor such proof was duly filed.

The Supervisor announced that the Town Board would hear all persons interested in the subject of the hearing. Comments were heard, after which the Supervisor declared the hearing closed, decision was reserved.

RESULT: CLOSED [UNANIMOUS]
MOVER: Patricia Jaworowicz, Councilmember
SECONDER: James Rogowski, Councilmember
AYES: Holtz, Jaworowicz, Swiatek, Rogowski, Zydel, Markel, Kaznowski

IV. Resolutions



1. RESOLUTION 2011-141

Transfer of Funds - 2010

Sponsored By: Supervisor Holtz, Councilmember Swiatek

BE IT RESOLVED, that the following transfer is hereby approved and made a part hereof;

2010

GENERAL FUND

FROM:	100.3120.1902	Overtime Payroll	\$ 5,400.00
	100.9010.8143	Retirees Medical Insurance	26,153.00
	100.3120.2206	LEBG	5,554.09
	100.3120.2207	Jag Grant	70,650.57

TO:	100.3120.1917	Clothing Allowance	\$ 5,400.00
	100.9010.5995	Allocated Fringes	20,450.00
	100.9499.1901	Regular Payroll	1,584.00
	100.9499.1902	Overtime Payroll	1,214.00
	100.9199.1932	Sick Sellback	2,905.00
	100.3120.3820	State Aid Police	5,554.09
	100.3120.3820	State Aid Police	70,650.57

SPECIAL DISTRICTS FUND

FROM:	255.8125.4545	Telemetry	\$ 19.00
	255.8125.4545	Telemetry	97.00

TO:	255.8125.4217	Utilities	\$ 19.00
	255.8125.4217	Utilities	97.00

HIGHWAY FUND

FROM:	300.9010.8101	Retirement	\$ 79,060.00
	300.9010.8141	Medical Insurance	100,000.00
	300.9010.8143	Medical Insurance	73,000.00
	300.9501.9211	Bond Interest	64,440.00
	300.5141.1731	Labor Allocation	235,277.84
	300.5130.1701	Highway Machinery	25,087.99
	300.5140.1701	Brush & Weed	180,611.68
	300.5142.1701	Snow Removal	83,640.21
	300.5141.1736	Labor Allocation	4,411.32
	300.5141.1737	Labor Allocation	131,658.22
	300.9501.9211	Bond Interest	49,798.00
	300.9010.8975	Retirement Buyout	11,426.00
	300.9010.8101	Employees Retirement	14,946.00
	300.5141.1951	Seasonal Regular	18,959.00
	300.5141.1901	Regular Payroll	15,699.00
	300.5141.1911	Longevity	9,430.00
	300.5141.1914	Shift Differential	4,491.00

	300.9010.8121	Social Security	2,208.00
	300.9010.8141	Medical Insurance	1,155.00
	300.1910.2799	Appropriated Fund Balance	107,668.00
TO:	300.5141.1902	Overtime	\$ 79,060.00
	300.5142.4180	Contracted Snow Removal	237,440.00
	300.5110.1701	General Repairs	235,277.84
	300.5141.1733	Labor Allocation	25,087.99
	300.5140.1379	Brush & Weed	4,457.25
	300.5141.1734	Labor Allocation	176,154.43
	300.5141.1735	Labor Allocation	83,640.21
	300.5148.1701	Other Gov'ts	4,411.32
	300.5150.1701	Highway Improvements	131,658.22
	300.5142.4180	Contracted Snow Removal	235,780.00
<u>HUD CDBG FUND</u>			
FROM:	700.1010.0600	Rehab Single Family	\$ 31,341.71
	700.1010.0690	Accessibility	6,600.00
	700.1010.0704	Contingency	\$ 2,000.00
	700.1010.0600	Rehab Single Family	36,441.55
	700.1010.0753	Code Enforcement	2,285.33
	700.1010.0753	Code Enforcement	2,045.57
	700.1010.0600	Rehab Single Family	4,581.05
	700.1010.0752	Activity Delivery Costs	23,618.00
	700.1010.0703	Administration	60.30
TO:	700.1010.0601	Rehab Multi Family	\$ 31,341.71
	700.1010.0750	Housing Rehab Inspections	6,600.00
	700.1010.0750	Housing Rehab Inspections	2,000.00
	700.1010.0750	Housing Rehab Inspections	36,441.55
	700.1010.0795	Senior Citizen Outreach	2,285.33
	700.1010.0703	Administration	2,045.57
	700.1010.0703	Administration	23,618.00
	700.1010.0703	Administration	4,581.05
	700.1010.0750	Activity Delivery Costs	60.30

RESULT:	ADOPTED [UNANIMOUS]
MOVER:	Mary Holtz, Supervisor
SECONDER:	Jeff Swiatek, Councilmember
AYES:	Holtz, Jaworowicz, Swiatek, Rogowski, Zydel, Markel, Kaznowski



2. RESOLUTION 2011-142

Transfer of Funds - 2011

Sponsored By: Supervisor Holtz, Councilmember Swiatek

BE IT RESOLVED, that the following transfer is hereby approved and made a part hereof;

2011

GENERAL FUND

FROM: 100.1110.1971 Court Part-Time \$ 8,000.00

TO: 100.1625.1971 Building Maint. Part-Time \$ 8,000.00

SPECIAL DISTRICTS FUND

FROM: 255.8125.9201 Bond Interest \$ 50,000.00

TO: 255.8125.4545 Telemetry \$ 50,000.00

RESULT:	ADOPTED [UNANIMOUS]
MOVER:	Mary Holtz, Supervisor
SECONDER:	Jeff Swiatek, Councilmember
AYES:	Holtz, Jaworowicz, Swiatek, Rogowski, Zydel, Markel, Kaznowski



3. RESOLUTION 2011-143

Warrant

Sponsored By: Supervisor Holtz, Councilmember Swiatek

BE IT RESOLVED, that the following Vouchers & Warrants submitted to the Town of Cheektowaga prior to March 18, 2011 are hereby approved and made a part hereof;

GENERAL FUND	\$ 3,567,305.49
RISK RETENTION FUND	141,808.58
NYS HOME PROGRAM	1,325.00
DEBT SERVICE FUND	46,450.00
HUD HOUSING REHABILITATION	63,183.00
SPECIAL DISTRICTS FUND	1,510,800.83
HIGHWAY FUND	1,197,500.61
CAPITAL FUND	72,461.16
TRUST & AGENCY FUND	763.61
HUD CDBG FUND	501,843.87
PART TOWN FUND	188,732.37
NYS AFFORDABLE HOUSING	25,545.00
	<u>\$ 7,317,719.52</u>

RESULT: **ADOPTED [UNANIMOUS]**

MOVER: Mary Holtz, Supervisor

SECONDER: Jeff Swiatek, Councilmember

AYES: Holtz, Jaworowicz, Swiatek, Rogowski, Zydel, Markel, Kaznowski



4. RESOLUTION 2011-144

Adoption of Amendment to Parks Ordinance

Sponsored By: Councilmember Rogowski, Councilmember Kaznowski

WHEREAS, the Town of Cheektowaga previously adopted a Parks Ordinance (Chapter 174 of the Code of the Town of Cheektowaga) with amendments thereto, and Rules and Regulations governing Cheektowaga Town Parks which apply to all public parks and public park approaches owned by the Town of Cheektowaga, and

WHEREAS, the existing Parks Ordinance does not permit dogs in the parks or park approaches, and

WHEREAS, the Town of Cheektowaga would like to permit the walking of dogs on leashes in the various town parks, excluding John C. Stiglmeier Park and Cheektowaga Town Park, subject to certain restrictions, and

WHEREAS, in accordance with the provisions of the Town Law of the State of New York, a public hearing was held on the 7th day of March, 2011 at 6:45 P.M. at a meeting of the Town Board at the Cheektowaga Town Hall, 3301 Broadway, Cheektowaga, New York, at which hearing all parties in interest and citizens had an opportunity to be heard as to whether Chapter 174 of the Code of the Town of Cheektowaga ("Parks Ordinance") should be amended as provided in the Notice of Hearing, and

WHEREAS, it is in the public interest to adopt the aforesaid proposed amendment to the Parks Ordinance, NOW, THEREFORE, BE IT

RESOLVED, that the Parks Ordinance (Chapter 174) of the Code of the Town of Cheektowaga) be and hereby is amended as follows:

§174-8. Domestic animals prohibited from parks and park approaches, shall be amended, effective April 1, 2011, and expiring on December 31, 2011, to read as follows:

§ 174-8. Domestic animals in parks and park approaches.

A. Dogs shall be permitted in town parks, except for John C. Stiglmeier Park and Cheektowaga Town Park, subject to the following conditions/limitations:

- (1) Dogs must be restrained/hand-controlled by leash (no longer than six feet in length);
- (2) No person walking or in charge of any dog in said area(s) shall cause, suffer or allow such dog to soil, defecate on or commit any nuisance in said area (unless said person picks up and properly disposes of the feces in an appropriate container); and
- (3) Dogs shall not be permitted on any park lands designated for sport fields and/or in areas immediately adjacent to playground structures.

B. Dogs shall be permitted in the area designated as the Alexander Walking Path

(described as follows: the park area/walking trail area on the east side of Scajaquada Creek east and north of the Alexander Community Center, but not including any area east of the parking lot for the Cheektowaga Recreation Center/Ice Rink building), subject to the conditions and limitations contained in subsections (A)(1), (A)(2), and (A)(3) of this section.

, and BE IT FURTHER

RESOLVED, that a copy of this resolution be entered in the minutes of the meeting of the Town Board of the Town of Cheektowaga held on the 21st day of March, 2011, and that a certified copy hereof be published in the CHEEKTOWAGA BEE, the official Town newspaper, and BE IT FURTHER

RESOLVED, that this amendment shall become effective April 1, 2011 after publishing and posting as required by statute, and shall expire on December 31, 2011.

RESULT:	ADOPTED [UNANIMOUS]
MOVER:	Patricia Jaworowicz, James Rogowski
SECONDER:	Stanley Kaznowski, Councilmember
AYES:	Holtz, Jaworowicz, Swiatek, Rogowski, Zydel, Markel, Kaznowski



5. RESOLUTION 2011-145

Bond Resolution - Highway Repaving

Sponsored By: Supervisor Holtz, Councilmember Swiatek

BOND RESOLUTION OF THE TOWN OF CHEEKTOWAGA, NEW YORK, ADOPTED MARCH 21, 2011, AUTHORIZING THE RECONSTRUCTION AND RESURFACING OF VARIOUS TOWN HIGHWAYS, STATING THE ESTIMATED MAXIMUM COST THEREOF IS \$1,300,000, APPROPRIATING SAID AMOUNT FOR SUCH PURPOSE, AND AUTHORIZING THE ISSUANCE OF \$1,300,000 SERIAL BONDS OF SAID TOWN TO FINANCE SAID APPROPRIATION

THE TOWN BOARD OF THE TOWN OF CHEEKTOWAGA, IN THE COUNTY OF ERIE, NEW YORK, HEREBY RESOLVES (by the favorable vote of not less than two-thirds of all the members of said Town Board) AS FOLLOWS:

Section 1. The Town of Cheektowaga, in the County of Erie, New York (herein called the "Town"), is hereby authorized to reconstruct and resurface various Town highways. The estimated maximum cost thereof, including preliminary costs and costs incidental thereto and the financing thereof, is \$1,300,000 and said amount is hereby appropriated for such purpose. The plan of financing includes the issuance of \$1,300,000 serial bonds of the Town to finance said appropriation, and the levy and collection of taxes on all the taxable real property in the Town to pay the principal of said bonds and the interest thereon as the same shall become due and payable.

Section 2. Serial bonds of the Town in the principal amount of \$1,300,000 are hereby authorized to be issued pursuant to the provisions of the Local Finance Law, constituting Chapter 33-a of the Consolidated Laws of the State of New York (herein called the "Law"), to

finance said appropriation.

Section 3. The following additional matters are hereby determined and declared:

(a) The period of probable usefulness applicable to the object or purpose for which said bonds are authorized to be issued, within the limitations of Section 11.00 a. 20(c) of the Law, is fifteen (15) years.

(b) The proceeds of the bonds herein authorized and any bond anticipation notes issued in anticipation of said bonds may be applied to reimburse the Town for expenditures made after the effective date of this resolution for the purpose for which said bonds are authorized. The foregoing statement of intent with respect to reimbursement is made in conformity with Treasury Regulation Section 1.150-2 of the United States Treasury Department.

(c) The proposed maturity of the bonds authorized by this resolution will exceed five (5) years.

Section 4. Each of the bonds authorized by this resolution and any bond anticipation notes issued in anticipation of the sale of said bonds shall contain the recital of validity as prescribed by Section 52.00 of the Law and said bonds and any notes issued in anticipation of said bonds shall be general obligations of the Town, payable as to both principal and interest by general tax upon all the taxable real property within the Town without limitation of rate or amount. The faith and credit of the Town are hereby irrevocably pledged to the punctual payment of the principal of and interest on said bonds and any notes issued in anticipation of the sale of said bonds and provision shall be made annually in the budget of the Town by appropriation for (a) the amortization and redemption of the bonds and any notes in anticipation thereof to mature in such year and (b) the payment of interest to be due and payable in such year.

Section 5. Subject to the provisions of this resolution and of the Law and pursuant to the provisions of Section 21.00 relative to the authorization of bonds with

substantially level or declining annual debt service, Section 30.00 relative to the authorization of the issuance of bond anticipation notes and Section 50.00 and Sections 56.00 to 60.00 and Section 168.00 of the Law, the powers and duties of the Town Board relative to authorizing bond anticipation notes and prescribing the terms, form and contents and as to the sale and issuance of the bonds herein authorized, and of any bond anticipation notes issued in anticipation of said bonds, and the renewals of said bond anticipation notes, and as to the execution of agreements for credit enhancements, are hereby delegated to the Supervisor, the chief fiscal officer of the Town.

Section 6. The validity of the bonds authorized by this resolution, and of any notes issued in anticipation of the sale of said bonds, may be contested only if:

- (a) such obligations are authorized for an object or purpose for which the Town is not authorized to expend money, or
- (b) the provisions of law which should be complied with at the date of the publication of such resolution, or a summary thereof, are not substantially complied with,

and an action, suit or proceeding contesting such validity is commenced within twenty days after the date of such publication, or

- (c) such obligations are authorized in violation of the provisions of the constitution.

Section 7. This bond resolution is subject to a permissive referendum and the Town Clerk is hereby authorized and directed, within ten (10) days after the adoption of this resolution, to cause to be published, in full, in the "*Cheektowaga Bee*," a newspaper having a general circulation within said Town and hereby designated the official newspaper of the Town for such publication and posted on the sign board of the Town maintained pursuant to the Town Law, a Notice in substantially the following form:

TOWN OF CHEEKTOWAGA, NEW YORK

PLEASE TAKE NOTICE that on March 21, 2011, the Town Board of the Town of Cheektowaga, in the County of Erie, New York, adopted a bond resolution entitled:

“Bond Resolution of the Town of Cheektowaga, New York, adopted March 21, 2011, authorizing the reconstruction and resurfacing of various Town highways, stating the estimated maximum cost thereof is \$1,300,000, appropriating said amount for such purpose, and authorizing the issuance of \$1,300,000 serial bonds of said Town to finance said appropriation,”

an abstract of which bond resolution concisely stating the purpose and effect thereof, being as follows:

FIRST: AUTHORIZING said Town to reconstruct and resurface various Town highways; STATING the estimated maximum cost thereof, including preliminary costs, and costs incidental thereto and the financing thereof, is \$1,300,000; APPROPRIATING said amount for such purpose; and STATING the plan of financing includes the issuance of \$1,300,000 serial bonds of the Town to finance said appropriation, and the levy of a tax upon all the taxable real property within the Town to pay the principal of said bonds and interest thereon;

SECOND: AUTHORIZING the issuance of \$1,300,000 serial bonds of the Town pursuant to the Local Finance Law of the State of New York (the “Law”) to finance said appropriation;

THIRD: DETERMINING and STATING the period of probable usefulness applicable to the purpose for which said serial bonds are authorized to be issued is fifteen (15) years; the proceeds of said bonds and any bond anticipation notes issued in anticipation thereof may be applied to reimburse the Town for expenditures made after the effective date of this bond resolution for the purpose for which said bonds are authorized; and the proposed maturity of said \$1,300,000 serial bonds will exceed five (5) years;

FOURTH: DETERMINING that said bonds and any bond anticipation notes issued in anticipation of said bonds and the renewals of said bond anticipation notes shall be general obligations of the Town; and PLEDGING to their payment the faith and credit of the Town;

FIFTH: DELEGATING to the Supervisor the powers and duties as to the issuance of said bonds and any bond anticipation notes issued in anticipation of said bonds, or the renewals thereof; and

SIXTH: DETERMINING that the bond resolution is subject to a permissive referendum.

DATED: March 21, 2011

Alice Magierski
Town Clerk

Section 8. The Town Clerk is hereby authorized and directed to cause said bond resolution to be published, in summary, after said bond resolution shall take effect, in the newspaper referred to in Section 7 hereof, and hereby designated the official newspaper for said publication, together with a Notice in substantially the form as provided by Section 81.00 of the Local Finance Law, constituting Chapter 33-a of the Consolidated Laws of the State of New York.

* * *

RESULT:	ADOPTED [UNANIMOUS]
MOVER:	Mary Holtz, Supervisor
SECONDER:	Jeff Swiatek, Councilmember
AYES:	Holtz, Jaworowicz, Swiatek, Rogowski, Zydel, Markel, Kaznowski



6. RESOLUTION 2011-146

Bond Resolution - Highway Drainage

Sponsored By: Supervisor Holtz, Councilmember Swiatek

BOND RESOLUTION OF THE TOWN OF CHEEKTOWAGA, NEW YORK, ADOPTED MARCH 21, 2011, AUTHORIZING THE CONSTRUCTION OF DRAINAGE IMPROVEMENTS ON TOWN HIGHWAYS, STATING THE ESTIMATED MAXIMUM COST THEREOF IS \$1,800,000, APPROPRIATING SAID AMOUNT FOR SUCH PURPOSE, AND AUTHORIZING THE ISSUANCE OF \$1,800,000 SERIAL BONDS OF SAID TOWN TO FINANCE SAID APPROPRIATION

THE TOWN BOARD OF THE TOWN OF CHEEKTOWAGA, IN THE COUNTY OF ERIE, NEW YORK, HEREBY RESOLVES (by the favorable vote of not less than two-thirds of all the members of said Town Board) AS FOLLOWS:

Section 1. The Town of Cheektowaga, in the County of Erie, New York (herein called the "Town"), is hereby authorized to construct drainage improvements on Town highways. The estimated maximum cost thereof, including preliminary costs and costs incidental thereto and the financing thereof, is \$1,800,000 and said amount is hereby appropriated for such purpose. The plan of financing includes the issuance of \$1,800,000 serial bonds of the Town to finance said appropriation, and the levy and collection of taxes on all the taxable real property in the Town to pay the principal of said bonds and the interest thereon as the same shall become due and payable.

Section 2. Serial bonds of the Town in the principal amount of \$1,800,000 are hereby authorized to be issued pursuant to the provisions of the Local Finance Law, constituting Chapter 33-a of the Consolidated Laws of the State of New York (herein called the "Law"), to

finance said appropriation.

Section 3. The following additional matters are hereby determined and declared:

(a) The period of probable usefulness applicable to the object or purpose for which said bonds are authorized to be issued, within the limitations of Section 11.00 a. 4 of the Law, is forty (40) years.

(b) The proceeds of the bonds herein authorized and any bond anticipation notes issued in anticipation of said bonds may be applied to reimburse the Town for expenditures made after the effective date of this resolution for the purpose for which said bonds are authorized. The foregoing statement of intent with respect to reimbursement is made in conformity with Treasury Regulation Section 1.150-2 of the United States Treasury Department.

(c) The proposed maturity of the bonds authorized by this resolution will exceed five (5) years.

Section 4. Each of the bonds authorized by this resolution and any bond anticipation notes issued in anticipation of the sale of said bonds shall contain the recital of validity as prescribed by Section 52.00 of the Law and said bonds and any notes issued in anticipation of said bonds shall be general obligations of the Town, payable as to both principal and interest by general tax upon all the taxable real property within the Town without limitation of rate or amount. The faith and credit of the Town are hereby irrevocably pledged to the punctual payment of the principal of and interest on said bonds and any notes issued in anticipation of the sale of said bonds and provision shall be made annually in the budget of the Town by appropriation for (a) the amortization and redemption of the bonds and any notes in anticipation thereof to mature in such year and (b) the payment of interest to be due and payable in such year.

Section 5. Subject to the provisions of this resolution and of the Law and pursuant to the provisions of Section 21.00 relative to the authorization of bonds with

substantially level or declining annual debt service, Section 30.00 relative to the authorization of the issuance of bond anticipation notes and Section 50.00 and Sections 56.00 to 60.00 and Section 168.00 of the Law, the powers and duties of the Town Board relative to authorizing bond anticipation notes and prescribing the terms, form and contents and as to the sale and issuance of the bonds herein authorized, and of any bond anticipation notes issued in anticipation of said bonds, and the renewals of said bond anticipation notes, and as to the execution of agreements for credit enhancements, are hereby delegated to the Supervisor, the chief fiscal officer of the Town.

Section 6. The validity of the bonds authorized by this resolution, and of any notes issued in anticipation of the sale of said bonds, may be contested only if:

- (a) such obligations are authorized for an object or purpose for which the Town is not authorized to expend money, or
- (b) the provisions of law which should be complied with at the date of the publication of such resolution, or a summary thereof, are not substantially complied with,

and an action, suit or proceeding contesting such validity is commenced within twenty days after the date of such publication, or

- (c) such obligations are authorized in violation of the provisions of the constitution.

Section 7. This bond resolution is subject to a permissive referendum and the Town Clerk is hereby authorized and directed, within ten (10) days after the adoption of this resolution, to cause to be published, in full, in the "*Cheektowaga Bee*," a newspaper having a general circulation within said Town and hereby designated the official newspaper of the Town for such publication and posted on the sign board of the Town maintained pursuant to the Town Law, a Notice in substantially the following form:

TOWN OF CHEEKTOWAGA, NEW YORK

PLEASE TAKE NOTICE that on March 21, 2011, the Town Board of the Town of Cheektowaga, in the County of Erie, New York, adopted a bond resolution entitled:

“Bond Resolution of the Town of Cheektowaga, New York, adopted March 21, 2011, authorizing the construction of drainage improvements on Town highways, stating the estimated maximum cost thereof is \$1,800,000, appropriating said amount for such purpose, and authorizing the issuance of \$1,800,000 serial bonds of said Town to finance said appropriation,”

an abstract of which bond resolution concisely stating the purpose and effect thereof, being as follows:

FIRST: AUTHORIZING said Town to construct drainage improvements on Town highways; STATING the estimated maximum cost thereof, including preliminary costs, and costs incidental thereto and the financing thereof, is \$1,800,000; APPROPRIATING said amount for such purpose; and STATING the plan of financing includes the issuance of \$1,800,000 serial bonds of the Town to finance said appropriation, and the levy of a tax upon all the taxable real property within the Town to pay the principal of said bonds and interest thereon;

SECOND: AUTHORIZING the issuance of \$1,800,000 serial bonds of the Town pursuant to the Local Finance Law of the State of New York (the “Law”) to finance said appropriation;

THIRD: DETERMINING and STATING the period of probable usefulness applicable to the purpose for which said serial bonds are authorized to be issued is forty (40) years; the proceeds of said bonds and any bond anticipation notes issued in anticipation thereof may be applied to reimburse the Town for expenditures made after the effective date of this bond resolution for the purpose for which said bonds are authorized; and the proposed maturity of said \$1,800,000 serial bonds will exceed five (5) years;

FOURTH: DETERMINING that said bonds and any bond anticipation notes issued in anticipation of said bonds and the renewals of said bond anticipation notes shall be general obligations of the Town; and PLEDGING to their payment the faith and credit of the Town;

FIFTH: DELEGATING to the Supervisor the powers and duties as to the issuance of said bonds and any bond anticipation notes issued in anticipation of said bonds, or the renewals thereof; and

SIXTH: DETERMINING that the bond resolution is subject to a permissive referendum.

DATED: March 21, 2011

Alice Magierski
Town Clerk

Section 8. The Town Clerk is hereby authorized and directed to cause said bond resolution to be published, in summary, after said bond resolution shall take effect, in the newspaper referred to in Section 7 hereof, and hereby designated the official newspaper for said publication, together with a Notice in substantially the form as provided by Section 81.00 of the Local Finance Law, constituting Chapter 33-a of the Consolidated Laws of the State of New York.

* * *

RESULT:	ADOPTED [UNANIMOUS]
MOVER:	Mary Holtz, Supervisor
SECONDER:	Jeff Swiatek, Councilmember
AYES:	Holtz, Jaworowicz, Swiatek, Rogowski, Zydel, Markel, Kaznowski



7. RESOLUTION 2011-147

Bond Resolution - Sidewalks

Sponsored By: Supervisor Holtz, Councilmember Swiatek

BOND RESOLUTION OF THE TOWN OF CHEEKTOWAGA, NEW YORK, ADOPTED MARCH 21, 2011, AUTHORIZING THE RECONSTRUCTION OF VARIOUS SIDEWALKS IN THE TOWN, STATING THE ESTIMATED MAXIMUM COST THEREOF IS \$200,000, APPROPRIATING SAID AMOUNT FOR SUCH PURPOSE, AND AUTHORIZING THE ISSUANCE OF \$200,000 SERIAL BONDS OF SAID TOWN TO FINANCE SAID APPROPRIATION

THE TOWN BOARD OF THE TOWN OF CHEEKTOWAGA, IN THE COUNTY OF ERIE, NEW YORK, HEREBY RESOLVES (by the favorable vote of not less than two-thirds of all the members of said Town Board) AS FOLLOWS:

Section 1. The Town of Cheektowaga, in the County of Erie, New York (herein called the "Town"), is hereby authorized to reconstruct various sidewalks in the Town. The estimated maximum cost thereof, including preliminary costs and costs incidental thereto and the financing thereof, is \$200,000 and said amount is hereby appropriated for such purpose. The plan of financing includes the issuance of \$200,000 serial bonds of the Town to finance said appropriation, and the levy and collection of taxes on all the taxable real property in the Town to pay the principal of said bonds and the interest thereon as the same shall become due and payable.

Section 2. Serial bonds of the Town in the principal amount of \$200,000 are hereby authorized to be issued pursuant to the provisions of the Local Finance Law, constituting Chapter 33-a of the Consolidated Laws of the State of New York (herein called the "Law"), to

finance said appropriation.

Section 3. The following additional matters are hereby determined and declared:

(a) The period of probable usefulness applicable to the object or purpose for which said bonds are authorized to be issued, within the limitations of Section 11.00 a. 24 of the Law, is ten (10) years.

(b) The proceeds of the bonds herein authorized and any bond anticipation notes issued in anticipation of said bonds may be applied to reimburse the Town for expenditures made after the effective date of this resolution for the purpose for which said bonds are authorized. The foregoing statement of intent with respect to reimbursement is made in conformity with Treasury Regulation Section 1.150-2 of the United States Treasury Department.

(c) The proposed maturity of the bonds authorized by this resolution will exceed five (5) years.

Section 4. Each of the bonds authorized by this resolution and any bond anticipation notes issued in anticipation of the sale of said bonds shall contain the recital of validity as prescribed by Section 52.00 of the Law and said bonds and any notes issued in anticipation of said bonds shall be general obligations of the Town, payable as to both principal and interest by general tax upon all the taxable real property within the Town without limitation of rate or amount. The faith and credit of the Town are hereby irrevocably pledged to the punctual payment of the principal of and interest on said bonds and any notes issued in anticipation of the sale of said bonds and provision shall be made annually in the budget of the Town by appropriation for (a) the amortization and redemption of the bonds and any notes in anticipation thereof to mature in such year and (b) the payment of interest to be due and payable in such year.

Section 5. Subject to the provisions of this resolution and of the Law and pursuant to the provisions of Section 21.00 relative to the authorization of bonds with

substantially level or declining annual debt service, Section 30.00 relative to the authorization of the issuance of bond anticipation notes and Section 50.00 and Sections 56.00 to 60.00 and Section 168.00 of the Law, the powers and duties of the Town Board relative to authorizing bond anticipation notes and prescribing the terms, form and contents and as to the sale and issuance of the bonds herein authorized, and of any bond anticipation notes issued in anticipation of said bonds, and the renewals of said bond anticipation notes, and as to the execution of agreements for credit enhancements, are hereby delegated to the Supervisor, the chief fiscal officer of the Town.

Section 6. The validity of the bonds authorized by this resolution, and of any notes issued in anticipation of the sale of said bonds, may be contested only if:

- (a) such obligations are authorized for an object or purpose for which the Town is not authorized to expend money, or
- (b) the provisions of law which should be complied with at the date of the publication of such resolution, or a summary thereof, are not substantially complied with,

and an action, suit or proceeding contesting such validity is commenced within twenty days after the date of such publication, or

- (c) such obligations are authorized in violation of the provisions of the constitution.

Section 7. This bond resolution is subject to a permissive referendum and the Town Clerk is hereby authorized and directed, within ten (10) days after the adoption of this resolution, to cause to be published, in full, in the "*Cheektowaga Bee*," a newspaper having a general circulation within said Town and hereby designated the official newspaper of the Town for such publication and posted on the sign board of the Town maintained pursuant to the Town Law, a Notice in substantially the following form:

TOWN OF CHEEKTOWAGA, NEW YORK

PLEASE TAKE NOTICE that on March 21, 2011, the Town Board of the Town of Cheektowaga, in the County of Erie, New York, adopted a bond resolution entitled:

“Bond Resolution of the Town of Cheektowaga, New York, adopted March 21, 2011, authorizing the reconstruction of various sidewalks in the Town, stating the estimated maximum cost thereof is \$200,000, appropriating said amount for such purpose, and authorizing the issuance of \$200,000 serial bonds of said Town to finance said appropriation,”

an abstract of which bond resolution concisely stating the purpose and effect thereof, being as follows:

FIRST: AUTHORIZING said Town to reconstruct various sidewalks in the Town; STATING the estimated maximum cost thereof, including preliminary costs, and costs incidental thereto and the financing thereof, is \$200,000; APPROPRIATING said amount for such purpose; and STATING the plan of financing includes the issuance of \$200,000 serial bonds of the Town to finance said appropriation, and the levy of a tax upon all the taxable real property within the Town to pay the principal of said bonds and interest thereon;

SECOND: AUTHORIZING the issuance of \$200,000 serial bonds of the Town pursuant to the Local Finance Law of the State of New York (the “Law”) to finance said appropriation;

THIRD: DETERMINING and STATING the period of probable usefulness applicable to the purpose for which said serial bonds are authorized to be issued is ten (10) years; the proceeds of said bonds and any bond anticipation notes issued in anticipation thereof may be applied to reimburse the Town for expenditures made after the effective date of this bond resolution for the purpose for which said bonds are authorized; and the proposed maturity of said \$200,000 serial bonds will exceed five (5) years;

FOURTH: DETERMINING that said bonds and any bond anticipation notes issued in anticipation of said bonds and the renewals of said bond anticipation notes shall be general obligations of the Town; and PLEDGING to their payment the faith and credit of the Town;

FIFTH: DELEGATING to the Supervisor the powers and duties as to the issuance of said bonds and any bond anticipation notes issued in anticipation of said bonds, or the renewals thereof; and

SIXTH: DETERMINING that the bond resolution is subject to a permissive referendum.

DATED: March 21, 2011

Alice Magierski
Town Clerk

Section 8. The Town Clerk is hereby authorized and directed to cause said bond resolution to be published, in summary, after said bond resolution shall take effect, in the newspaper referred to in Section 7 hereof, and hereby designated the official newspaper for said publication, together with a Notice in substantially the form as provided by Section 81.00 of the Local Finance Law, constituting Chapter 33-a of the Consolidated Laws of the State of New York.

* * *

RESULT:	ADOPTED [UNANIMOUS]
MOVER:	Mary Holtz, Supervisor
SECONDER:	Jeff Swiatek, Councilmember
AYES:	Holtz, Jaworowicz, Swiatek, Rogowski, Zydel, Markel, Kaznowski



8. RESOLUTION 2011-148

Call for Public Hearing - a Local Law to Amend the Code of Ethics

Sponsored By: Councilmember Markel, Councilmember Swiatek

WHEREAS, pursuant to Sections 811 and 812 of the General Municipal Law of the State of New York, the Town of Cheektowaga previously adopted a Code of Ethics (now Chapter 18 of the Code of the Town of Cheektowaga), and

WHEREAS, Section 18-4 of said Code of Ethics requires certain Town employees and elected officials to file financial disclosure statements each year with the Board of Ethics, and

WHEREAS, some of the titles listed in Section 18-14 which are required to file a financial disclosure statement have changed over the years, and there is a need to update the Code of Ethics to reflect these changes, as well as to reflect other changes in job duties for those required to file financial disclosure statement, and

WHEREAS, the Town Attorney has prepared a draft of a "Local Law to Amend the Code of Ethics", NOW, THEREFORE, BE IT

RESOLVED, that, in accordance with the provisions of the Town Law/Municipal Home Rule Law of the State of New York, a public hearing shall be held on the 4th day of April, 2011 at 6:45 P.M. at a meeting of the Town Board at the Cheektowaga Town Hall, 3301 Broadway, Cheektowaga, New York; at which hearing all interested parties will be given an opportunity to be heard and at which time and place it may be determined by the Town Board whether Local Law Intro No. 2011-1 of the Year 2011, entitled "A Local Law to Amend the Ethics Law" should be enacted, and BE IT FURTHER

RESOLVED, that the Town Clerk shall publish the attached Notice of Hearing in the CHEEKTOWAGA BEE, the official Town newspaper.

LEGAL NOTICE

NOTICE IS HEREBY GIVEN that a public hearing will be held by the Town Board of the Town of Cheektowaga, Erie County, New York at the Town Hall, 3301 Broadway, Cheektowaga, New York, on the 4th day of April, 2011 at 6:45 P.M. on said day for the purpose of considering the adoption of Local Law Intro No. 2011-1 of the Year 2011, entitled "A Local Law to Amend the Code of Ethics". A summary of such Local Law is as follows:

LOCAL LAW NO. 2011-1 OF THE YEAR 2011

A LOCAL LAW TO AMEND THE CODE OF ETHICS

This local law would revise Section 18-14 of the Town Code, which requires certain Town

employees and elected officials to file financial disclosure forms with the Board of Ethics. The current list of officers and employees would be replaced with a statement that the Town Board will, by resolution, designate those employees and officers who must file this form. The list of titles would be updated.

A copy of the entire text of Local Law Intro No. 2011-1 is on file in the Town Clerk's Office, where the same may be viewed during regular business hours

BY ORDER OF THE TOWN BOARD OF THE TOWN OF CHEEKTOWAGA, ERIE
COUNTY, NEW YORK.

Dated: March 21, 2011

ALICE MAGIERSKI
Town Clerk

RESULT:	ADOPTED [UNANIMOUS]
MOVER:	Charles Markel, Councilmember
SECONDER:	Jeff Swiatek, Councilmember
AYES:	Holtz, Jaworowicz, Swiatek, Rogowski, Zydel, Markel, Kaznowski



9. RESOLUTION 2011-149

Negative SEQR Declaration-Town Solar Energy Project

Sponsored By: Councilmember Kaznowski, Supervisor Holtz

WHEREAS, pursuant to the Environmental Impact Review Ordinance of the Town of Cheektowaga, the Environmental Advisory Committee ("EAC") reviews various applications for site plans, rezonings, special permits, etc. and renders its recommendation concerning the environmental significance of such application, AND

WHEREAS, the Town Board, pursuant to the Environmental Impact Review Ordinance of the Town of Cheektowaga, is designated the Lead Agency in most instances, AND

WHEREAS, since the Town Board is the Lead Agency, it must affirm, modify or reject any recommendations submitted to it by the Advisory Committee, AND

WHEREAS, an application was submitted by the Town of Cheektowaga Engineering Department for the installation of solar electric energy systems on four (4) buildings owned by and maintained by the Town of Cheektowaga, AND

WHEREAS, the Environmental Advisory Committee at its meetings held on March 2, 2011 recommended a determination of non-significance as shown on the attached memorandum dated March 2, 2011, AND

WHEREAS, this Town Board has reviewed the application submitted and the recommendations made by the Environmental Advisory Committee NOW, THEREFORE, BE IT

RESOLVED, that this Town Board determines that the project will not have a significant effect on the environment and therefore issues a Negative Declaration for purposes of SEQRA,

RESULT:	ADOPTED [UNANIMOUS]
MOVER:	Stanley Kaznowski, Councilmember
SECONDER:	Mary Holtz, Supervisor
AYES:	Holtz, Jaworowicz, Swiatek, Rogowski, Zydel, Markel, Kaznowski



10. RESOLUTION 2011-150

Negative SEQR Declaration- 4590 Genesee Street

Sponsored By: Councilmember Kaznowski, Councilmember Markel

WHEREAS, pursuant to the Environmental Impact Review Ordinance of the Town of Cheektowaga, the Environmental Advisory Committee ("EAC") reviews various applications for site plans, rezonings, special permits, etc. and renders its recommendation concerning the environmental significance of such application, AND

WHEREAS, the Town Board, pursuant to the Environmental Impact Review Ordinance of the Town of Cheektowaga, is designated the Lead Agency in most instances, AND

WHEREAS, since the Town Board is the Lead Agency, it must affirm, modify or reject any recommendations submitted to it by the Advisory Committee, AND

WHEREAS, an application was submitted by NOCO Energy Corp. for the construction of a 4,632 square foot convenience store with a petroleum sales canopy structure at 4590 Genesee Street, AND

WHEREAS, the Environmental Advisory Committee at its meetings held on March 2, 2011 recommended a determination of non-significance as shown on the attached memorandum dated March 2, 2011, AND

WHEREAS, the Town of Cheektowaga Planning Board recommended approval of the site plan and building architecture at their meeting of March 10, 2011, AND

WHEREAS, the Town of Cheektowaga Traffic Safety Commission has reviewed the site plan and is recommending its approval, AND

WHEREAS, the subject project requires area variances from the Cheektowaga Zoning Board of Appeals due to site constraints caused by the NYSDOT highway taking and due to the site's proximity to the Buffalo Niagara International Airport, AND

WHEREAS, on June 19, 2006 this Town Board previously issued a negative SEQR declaration on this project, which then included an accessory drive thru window and, which is now eliminated AND,

WHEREAS, this Town Board has reviewed the application submitted and the recommendations made by the Environmental Advisory Committee, the Planning Board and the Traffic Safety Commission NOW, THEREFORE, BE IT

RESOLVED, that this Town Board determines that the project will not have a significant effect on the environment and therefore re-affirms the Negative Declaration previously issued for purposes of SEQRA, AND BE IT

FURTHER RESOLVED, the proposed site plan is found to be acceptable subject to :

1. The Town Engineer reviewing and approving the drainage/grading plan.

2. The Cheektowaga Zoning Board of Appeals granting the necessary area variances.

RESULT:	ADOPTED [UNANIMOUS]
MOVER:	Stanley Kaznowski, Councilmember
SECONDER:	Charles Markel, Councilmember
AYES:	Holtz, Jaworowicz, Swiatek, Rogowski, Zydel, Markel, Kaznowski



11. RESOLUTION 2011-151

Accept Site Plan for 555 Como Park Boulevard

Sponsored By: Councilmember Markel, Councilmember Rogowski

WHEREAS, pursuant to the Zoning Law of the Town of Cheektowaga, the Planning Board reviews various development review applications for site plans, rezonings, special permits and realty subdivisions and renders its recommendation concerning the compatibility of such application with the zoning regulations, Town Master Plan and neighborhood character, AND

WHEREAS, the Town Board, pursuant to the Zoning Law of the Town of Cheektowaga, is required to affirm, modify or reject any recommendation submitted to it by the Planning Board, AND

WHEREAS, a development review application and site plan was submitted by Left Coast Design Studio Architecture, P.C. for the construction of a seven hundred and fifty (750) square foot building addition to an existing administrative office at 555 Como Park Boulevard, AND

WHEREAS, the Town of Cheektowaga Planning Board at its meeting of January 13, 2011 is recommending the approval of the site plan, AND

WHEREAS, this Town Board has reviewed the development review application and recommendations made by the Planning Board, NOW THEREFORE, BE IT

RESOLVED, that this Town Board determines that the project site plan is acceptable.

RESULT:	ADOPTED [UNANIMOUS]
MOVER:	Charles Markel, Councilmember
SECONDER:	James Rogowski, Councilmember
AYES:	Holtz, Jaworowicz, Swiatek, Rogowski, Zydel, Markel, Kaznowski



12. RESOLUTION 2011-152

Authorize Town Clerk to Publish RFQ Consultant Solicitation Notice

Sponsored By: Councilmember Swiatek, Supervisor Holtz

WHEREAS, by resolution dated October 4, 2010 this Town Board authorized the execution of a Federal Aid Project Agreement with the New York State Department of Transportation (NYSDOT) for the rehabilitation of the Rein Road Bridge over Ellicott Creek, BIN 2212970, PIN 5758.38 being funded in part by Federal Highway Bridge Rehabilitation and Replacement (HBRR) Funds, AND

WHEREAS, pursuant to NYSDOT requirements and procedures for locally administered Federal Aid Projects, the Town is required to prepare a Request for Qualifications (RFQ) notice and follow specific procedures in order to select and engage an engineering consultant for this project, including the publication of the aforesaid RFQ Solicitation Notice in the New York State Contract Reporter, AND

WHEREAS, the Town Engineer has prepared such notice, which notice has been reviewed and approved by the NYSDOT Project Manager, which agency is also charged with the supervision of this Federal Grant, NOW, THEREFORE, BE IT

RESOLVED, that it is hereby directed that the aforementioned RFQ Consultant Solicitation Notice be published in the next available publication of the New York State Contract Reporter, AND, BE IT FURTHER

RESOLVED, that the Town Clerk be further directed to publish the aforesaid notice in the CHEEKTOWAGA BEE.

NOTICE

REQUEST FOR QUALIFICATIONS

Project or Contract Title: Rein Road over Ellicott Creek Bridge Rehabilitation Project
BIN 2212970, Town of Cheektowaga, Erie County, New York

Notice is hereby given that the Town of Cheektowaga is seeking to retain a professional engineering firm to provide Preliminary and Final Design Services, Phases I-VI for a Federally and Locally Funded project located in Erie County. The bridge rehabilitation project is funded in part by Federal Highway Bridge Rehabilitation and Replacement (HBRR) Funds, and the consultant firm or team shall provide services to facilitate Design Phases I thru VI as outlined in the NYSDOT Project Development Manual and in accordance with NYSDOT Procedures for Locally Administered Federal Aid Projects.

PIN 5758.38 provides for the rehabilitation of the single span, multi-girder through truss bridge, replacement of deteriorated steel members and decking, abutment repairs and restoration and cleaning and painting of the entire steel structure.

Preliminary Design (Design Phases I-IV) work includes obtaining public input, the engineering needed to select the right project, assessment of the social, economic and environmental impacts, the environmental determination, and other regulatory requirements. Preliminary design concludes with Design Approval. The detailed design (Design Phases V & VI) work includes the engineering efforts to obtain all needed permits and will include but not be limited to preparation and submission of the final Plans, Specifications and Estimate (PS&E) for the project.

The anticipated start date of design is June 2011 with the PS&E expected to be due in December 2011. The anticipated project cost is \$1.1 million.

The most highly qualified consultant shall be determined according to the following criteria listed in order of decreasing importance: 1. Experience of the proposed staff with projects of a similar scope; 2. Experience of the firm with projects of a similar scope; 3. Experience of the firm and staff with NYSDOT procedures; 4. Prior performance with the Town of Cheektowaga and logistics and familiarity with the project area.

Interested firms should submit six (6) copies of its Expression-Of-Interest (EOI) to the address below no later than 4:30 PM on April 15, 2011. An EOI shall be composed of an (SF) 254 and (SF) 255 form for each prime consultant and proposed subcontractors as well as a brief (no more than five (5) single sided pages) description of a proposed project approach and schedule of completion of key tasks. Proposers should list only those full time employees currently employed in (SF) 255; if listing experience for a specific project, provide date when this experience occurred; all individuals listed not currently employed by the firm must be identified as such; and provide the starting date of employment for all individuals employed for less than one year by the firm. The consultants may also be required to make an oral presentation.

The consultant may also be required to provide construction support services.

Disadvantaged Business Enterprises (DBE) are encouraged to submit proposals in response to this solicitation. Other proposers are encouraged to submit DBE subconsultants where appropriate.

Designated firms must submit proof of authority to practice architecture/engineering in NYS immediately upon designation.

Subconsultants, Subcontracting and/or joint ventures are permitted.

Proposal Due Date: April 15, 2011

Contract Term: 06/11 - 12/12

Location where services are to be performed: Erie County

For more information contact:
William R. Pugh, P.E.
Town Engineer
Town of Cheektowaga
275 Alexander Avenue
Cheektowaga, New York 14211
(716) 897-7288

Submit Proposals to:
Same

RESULT: **ADOPTED [UNANIMOUS]**
MOVER: Jeff Swiatek, Councilmember
SECONDER: Mary Holtz, Supervisor
AYES: Holtz, Jaworowicz, Swiatek, Rogowski, Zydel, Markel, Kaznowski



13. RESOLUTION 2011-153

Notice to Bidders - Solar Power Energy Systems

Sponsored By: Supervisor Holtz, Councilmember Swiatek

WHEREAS, by resolution dated December 6, 2010, the Town Board engaged the firm of Nussbaumer & Clarke, Inc. to prepare plans and specifications for the installation of solar power energy systems on the roofs of the Town Hall, Town Highway Garage, Losson Road Facilities Garage and three (3) circular garage structures at the Main Pump Station, the installation of which is funded through a grant from the U.S. Department of Energy under the American Recovery and Reinvestment Act of 2009, Energy Efficiency and Conservation Block Grants (EECBG) Program, AND

WHEREAS, said plans and specifications have been completed, enabling the solicitation of competitive bids, NOW, THEREFORE, BE IT

RESOLVED, that the Town Clerk be directed to publish a Notice to Bidders for the Installation of Solar Power Systems on Various Town of Cheektowaga Buildings, said notice to be published in the CHEEKTOWAGA BEE, AND, BE IT FURTHER

RESOLVED, that sealed bids for the aforesaid project will be received on the 13th day of April, 2011 at 11:00 a.m. at a public bid opening to be held in the Council Chambers in the Cheektowaga Town Hall.

NOTICE TO BIDDERS

NOTICE IS HEREBY GIVEN that sealed proposals will be received by the Town Board of the Town of Cheektowaga until 11:00 a.m., local time, on the 13th day of April, 2011. All bids will be publicly opened and read at 11:00 a.m. in the Town Hall, 3301 Broadway, Cheektowaga, New York 14227 for furnishing all tools, equipment, materials and labor for the Solar Power Systems on Various Town of Cheektowaga Buildings Project and all related work, complete in place, tested and ready for use in accordance with the contract documents, therefore, including plans, specifications, instructions to bidders, etc., prepared by Nussbaumer & Clarke, Inc., Consulting Engineers.

All proposals shall be submitted on the forms furnished herein and the entire volume, including any addenda, shall be submitted in a sealed envelope and addressed to the Town Clerk of the Town of Cheektowaga, 3301 Broadway, Cheektowaga, New York 14227, to the attention of Alice Magierski, Town Clerk, and marked "Solar Power Systems on Various Town of Cheektowaga Buildings".

The Contractor's name, title of the proposal, and date and time of the opening shall be clearly marked on the outside of the envelope.

Each proposal shall be accompanied by a certified check or bid bond in the amount of five percent (5%) of the amount of the bid and shall be in the form, and subject to the conditions, provided for in the Instructions to Bidders.

The successful bidder will be required to furnish a Performance Bond and a Labor and

Materials Payment Bond, each in the amount equal to the contract award. A Maintenance Bond for 100% of the contract price (including change orders) will be required during the maintenance period.

Copies of the drawings, specifications and contract documents may be examined at the Town Clerk's Office, Town Hall, 3301 Broadway, Cheektowaga, New York 14227. Copies may be purchased from the Town Clerk's Office and can be obtained upon payment of \$50.00 in the form of a check made payable to the Town of Cheektowaga, New York for each copy requested. Neither the Owner nor the Engineer will be responsible for full or partial sets of contract documents, including any addenda, obtained from any other source.

Any bidder returning drawings and specifications in good condition within 10 days following the bid opening will be refunded the full amount of the deposit. Non-bidders will be refunded one-half the deposit. Material suppliers and anyone returning the plans and specifications before the bid opening will be classified as non-bidders. Any bidders requesting more than one (1) set of drawings and specifications may purchase the excess, but it is understood that these are non-refundable.

The bidders' attention is called to Section 103-d of the General Municipal Law which requires a bidder's Certificate of Non-Collusion. Such certificate is part of the proposal form and, unless complied with on the form provided, the bid will not be accepted.

BIDDERS ON THIS WORK WILL BE REQUIRED TO COMPLY WITH THE PRESIDENT'S EXECUTIVE ORDER NO. 11246. THE REQUIREMENTS FOR BIDDERS AND CONTRACTORS UNDER THIS ORDER WHICH CONCERN NON-DISCRIMINATION IN EMPLOYMENT ARE EXPLAINED IN THE SPECIFICATIONS.

The attention of the bidder is called particularly to the requirements of conditions of employment to be observed and minimum wage rates to be paid under the contract.

The Town of Cheektowaga is an exempt organization under the Tax Law and is exempt from payment of sales and compensating use taxes of the State of New York and cities and counties of the state on all materials which are to be incorporated into the project, pursuant to the provisions of the contract. **These taxes are not to be included in the bid.**

A pre-bid meeting will be held at 9:00 a.m. on Tuesday, April 5, 2011 commencing at the Town of Cheektowaga Main Pumping Station #5, 171 Central Boulevard, Cheektowaga, New York. Attendance at the pre-bid meeting is recommended, but is not mandatory.

The work shall be completed within 180 consecutive calendar days, to begin five (5) days after the "Notice to Proceed" has been issued.

The right to reject any and all bids, to waive any informalities in, or to make an award to other than the low bidder, should it be deemed to be in the best interest of the Owner and in accordance with law, are herewith reserved.

No bidder may withdraw his bid within forty-five days after the date set for the opening thereof, but may withdraw same any time prior to the scheduled date for the opening of bids.

BY ORDER OF TOWN OF CHEEKTOWAGA

Alice Magierski
Town Clerk

DATED: March 21, 2011

PUBLISHED: March 24, 2011

RESULT: ADOPTED [UNANIMOUS]

MOVER: Mary Holtz, Supervisor

SECONDER: Jeff Swiatek, Councilmember

AYES: Holtz, Jaworowicz, Swiatek, Rogowski, Zydel, Markel, Kaznowski



14. RESOLUTION 2011-154

Notice to Bidders - 2011 Ford Expedition

Sponsored By: Councilmember Jaworowicz, Councilmember Rogowski

BE IT RESOLVED, that the Town Clerk is hereby directed to publish a Notice to Bidders for the purchase of one (1) New and Unused 2011 Ford Expedition Special Service Vehicle (Fire & Police Municipality Unit) or Equivalent, said notice to be published in the Cheektowaga Bee, be it further

RESOLVED, that sealed bids will be received by the Town Clerk on the 30th day of March, 2011, at 11:00 A.M., Eastern Standard Time, at a public bid opening to be held in the Council Chambers in the Cheektowaga Town Hall, 3301 Broadway, Cheektowaga, New York, 14227.

NOTICE TO BIDDERS

Sealed proposals will be received and opened by the Town Clerk of the Town of Cheektowaga on March 30th, 2011 at 11:00 A.M. in the Council Chambers, First Floor, Cheektowaga Town Hall, 3301 Broadway, Cheektowaga, New York, for the purchase of one (1) New and Unused 2011 Ford Expedition Special Service Vehicle (Fire & Police Municipality Unit) or Equivalent, as specified.

Information for bidders and specifications may be obtained from the Town Clerk at her office in said Town. One bid is to be submitted for the purchase of one (1) vehicle as specified the bid specifications.

The Town Board reserves the right to consider informal any bid not prepared and submitted in accordance with the provisions of the specifications and contract documents, and may waive any informalities, make an award to other than the low bidder, should it be in the best interest of the Town or reject any or all bids.

By order of the Town Board of the Town of Cheektowaga, Erie County, New York.

Alice Magierski

Town Clerk

Dated: March 21, 2011

Published: March 24, 2011

RESULT:	ADOPTED [UNANIMOUS]
MOVER:	Patricia Jaworowicz, Councilmember
SECONDER:	James Rogowski, Councilmember
AYES:	Holtz, Jaworowicz, Swiatek, Rogowski, Zydel, Markel, Kaznowski



15. RESOLUTION 2011-155

Notice to Bidders - Two (2) Sets of Completely Installed and Operational, Front Snow Plows, Wing Plows, Plow Rigging, Hydraulics, Dump Bodies and Accessories

Sponsored By: Councilmember Swiatek, Supervisor Holtz

NOTICE IS HEREBY GIVEN, that the Town of Cheektowaga Highway Department will receive bids for the purchase of TWO(2) SETS OF COMPLETELY INSTALLED AND OPERATIONAL, FRONT SNOW PLOWS, WING PLOWS, PLOW RIGGING, HYDRAULICS, DUMP BODIES AND ACCESSORIES for use by the Highway Department in the Town of Cheektowaga at a public bid opening to be held in the Council Chambers at the Cheektowaga Town Hall on April 6, 2011 at 11:00 A.M.

Information for bidders specifications may be obtained from the office of the Town Clerk, Cheektowaga Town Hall, Broadway and Union Roads, Cheektowaga, New York, between the hour of 9:00 AM and 4:30 PM, Monday through Friday, NOW THEREFORE BE IT

RESOLVED, that the Town Clerk is hereby designated as the Officer to open bids on the aforesaid items at a public bid opening on Wednesday, April 6, 2011, at 11:00 AM, in the Council Chambers of the Cheektowaga Town Hall.

TOWN OF CHEEKTOWAGA HIGHWAY DEPARTMENT LEGAL NOTICE TO BIDDERS

NOTICE IS HEREBY GIVEN, that the Town of Cheektowaga Highway Department will receive bids for the purchase of Two (2) sets of completely installed and operational, Front Snow Plows, Wing Plows, Plow rigging, Hydraulics, Dump Bodies and Accessories for use by the Highway Department in the Town of Cheektowaga at a public bid opening to be held in the Council Chambers at the Cheektowaga Town Hall on April 6, 2011 at 11:00 A.M.

Information for bidders and specifications may be obtained from the office of Alice Magierski, Town Clerk at his office located at Town Hall, Cheektowaga NY. Bids must be enclosed in an opaque envelope plainly marked "BID FOR TWO (2) SETS OF COMPLETELY INSTALLED AND OPERATIONAL, FRONT SNOW PLOWS, WING PLOWS, PLOW RIGGING, HYDRAULICS, DUMP BODIES AND ACCESSORIES. Non-Collusion forms must be signed and submitted with each bid. The Superintendent of Highways may reject any or all bids submitted.

ALICE MAGIERSKI, TOWN CLERK

DATE: March 21, 2011
PUBLISHED: March 24, 2011

RESULT: ADOPTED [UNANIMOUS]

MOVER: Jeff Swiatek, Councilmember
SECONDER: Mary Holtz, Supervisor
AYES: Holtz, Jaworowicz, Swiatek, Rogowski, Zydel, Markel, Kaznowski



16. RESOLUTION 2011-156

Notice to Bidders - Furnishing & Installation of Trees at the Town Hall Campus

Sponsored By: Supervisor Holtz, Councilmember Rogowski

WHEREAS, it is in order that bids be advertised for the furnishing and installation of various trees to be planted at the Town Hall Campus, Broadway & Union Roads, Cheektowaga, New York for the 2011 calendar year, AND

WHEREAS, the Engineering Department has prepared specifications for the aforesaid project, NOW, THEREFORE, BE IT

RESOLVED, that the Town Clerk be directed to publish a Notice to Bidders for the "Furnishing and Installation of Various Trees at the Town Hall Campus", said notice to be published in the CHEEKTOWAGA BEE, AND, BE IT FURTHER

RESOLVED, that sealed bids will be received on the 6th day of April, 2011 at 11:00 a.m., at a public bid opening to be held in the Council Chambers in the Cheektowaga Town Hall.

NOTICE TO BIDDERS

NOTICE IS HEREBY GIVEN that sealed proposals will be received and considered by the Town Board of the Town of Cheektowaga, County of Erie, State of New York, on the 6th day of April, 2011 at 11:00 a.m., in the Town Hall in the Town of Cheektowaga, New York, for the Furnishing and Installation of Trees at the Town Hall Campus, Broadway & Union Roads, in the Town of Cheektowaga.

Information for Bidders and specifications may be obtained from the Town Clerk at her office in said Town Hall.

Proposals shall be submitted in a sealed envelope, plainly marked on the outside "Bid for Furnishing and Installation of Trees at the Town Hall Campus" and submitted to the Town Clerk prior to bid opening.

Any bid not delivered in person shall be mailed to the Office of the Town Clerk, Town of Cheektowaga, Town Hall, Broadway and Union Roads, Cheektowaga, New York 14227.

The right to reject any and all bids, to waive any informalities in, or to make an award to other than the low bidder, should it be deemed to be in the best interest of the Town of Cheektowaga and in accordance with the law, are herewith reserved.

Each proposal must be accompanied by a certified check for a sum equal to five percent (5%) of the amount of the bid, payable to the order of the Town of Cheektowaga, New York, or bond with sufficient sureties to be approved by the attorney for the Town of Cheektowaga, New York, in a sum equal to five percent (5%) of the amount of the bid, conditioned that if his proposal is accepted, he will enter into a contract for the same, and that he will execute such further security as may be required for the faithful performance of the contract.

No bidder may withdraw his bid within thirty (30) days after the date set for the opening thereof, but may withdraw same any time prior to the scheduled date for the opening of bids.

The successful bidder will be required to furnish a Performance Bond acceptable to the Owner, in an amount equal to the contract award.

Attention of the bidders is further called to Section 103-d of the General Municipal Law which requires a Bidder's Certificate of Non-Collusion. Such certificate is part of the bid or proposal form, and unless complied with, such bid will not be accepted.

The Town of Cheektowaga is an exempt organization under the Tax Law and is exempt from payment of sales and compensating use taxes of the State of New York and cities and counties of the State on all materials which are to be incorporated into the project, pursuant to the provisions of the contract. These taxes are not to be included in the bid.

Alice Magierski
Town Clerk

DATED: March 21, 2011

RESULT:	ADOPTED [UNANIMOUS]
MOVER:	Mary Holtz, Supervisor
SECONDER:	James Rogowski, Councilmember
AYES:	Holtz, Jaworowicz, Swiatek, Rogowski, Zydel, Markel, Kaznowski



17. RESOLUTION 2011-157

Notice to Bidders Pool Maintenance Chemicals 2011

Sponsored By: Councilmember Zydel, Supervisor Holtz

WHEREAS, the Town of Cheektowaga Facilities Department, Parks Division, annually requires Pool Maintenance Chemicals for 2011, NOW, THEREFORE BE IT

RESOLVED, that the Town Clerk be directed to publish a Notice To Bidders for the furnishing of Pool Maintenance Chemicals, AND BE IT FURTHER

RESOLVED, that specifications for said Pool Maintenance Chemicals may be obtained from the Town Clerk's Office in Cheektowaga Town Hall, AND BE IT FURTHER

RESOLVED, that sealed bids will be received on the 30th day of March, 2011 at 11:00 AM at a public bid opening to be held in the Council Chambers at Cheektowaga Town Hall.

Notice to Bidders

Sealed proposals will be received by the Town Clerk on March 30, 2011, at 11:00 AM at Town Hall, 3301 Broadway, for the furnishing of Pool Maintenance Chemicals for the year 2011.

Information for bidders and specifications may be obtained from the Town Clerk at her office in Town Hall.

The Town Board reserves the right to consider informal any bid not prepared and submitted in accordance with the provisions of the specifications and contract documents and may waive any informalities, make an award to other than the low bidder should it be in the best interest of the Town, or reject any or all bids.

By Order of the Town Board of the Town of Cheektowaga, Erie County, New York.

Alice Magierski, Town Clerk
March 21, 2011

RESULT:	ADOPTED [UNANIMOUS]
MOVER:	Richard Zydel, Councilmember
SECONDER:	Mary Holtz, Supervisor
AYES:	Holtz, Jaworowicz, Swiatek, Rogowski, Zydel, Markel, Kaznowski



18. RESOLUTION 2011-158

Notice to Bidders - Athletic White Stripe 2011

Sponsored By: Councilmember Zydel, Supervisor Holtz

WHEREAS, the Town of Cheektowaga Facilities Department, Parks Division requires Athletic White Stripe for the purpose of lining athletic fields for 2011, NOW, THEREFORE, BE IT

RESOLVED, that the Town of Cheektowaga be directed to publish a Notice to Bidders for the purchase of Athletic White Stripe, AND BE IT FURTHER

RESOLVED, that specifications for said Athletic White Stripe may be obtained from the Town Clerks Office in Cheektowaga Town Hall, AND BE IT FURTHER

RESOLVED, that sealed bids will be received on the 30th day of March, 2011 at 11:00AM at a public bid opening to be held in the Council Chambers at Cheektowaga Town Hall.

Notice to Bidders

Sealed proposals will be received by the Town clerk on March 30, 2011, at 11:00 AM at the Town Hall, 3301 Broadway, for the supplying of Athletic White Stripe for the year 2011.

Information for bidders and specifications may be obtained from the Town Clerk at her office in Town Hall.

The Town Board reserves the right to consider informal any bid not prepared and submitted in accordance with the provisions of the specifications and contract documents and may waive any informalities, make an award to other than the low bidder should it be in the best interest of the Town, or reject any or all bids.

Alice Magierski, Town Clerk

March 21, 2011

RESULT:	ADOPTED [UNANIMOUS]
MOVER:	Richard Zydel, Councilmember
SECONDER:	Mary Holtz, Supervisor
AYES:	Holtz, Jaworowicz, Swiatek, Rogowski, Zydel, Markel, Kaznowski



19. RESOLUTION 2011-159

Award of Bid - Topsoil

Sponsored By: Councilmember Swiatek, Supervisor Holtz

WHEREAS, bids were duly received and opened by the Town Clerk at a public bid opening held on March 9, 2011 for TOPSOIL for use by the Town of Cheektowaga as result of advertisement thereof, and such bids were referred to the Superintendent of Highways for analysis, tabulation and reports, AND

WHEREAS, such analysis, tabulation and report have been completed, NOW THEREFORE, BE IT

RESOLVED, that the bid for TOPSOIL be awarded to Bengert Greenhouses, 230 French Road, West Seneca, NY 14224, for regular, screened, or shredded as per bid specifications and to be delivered to the Town of Cheektowaga, and

BE IT FURTHER RESOLVED, that payment of topsoil for Highway Department is charged to the line item #300-5110-4186.

**TABULATION FOR TOPSOIL
2011**

Bengert Greenhouses 230 French Road West Seneca, NY 14224 716-823-6114	Regular - \$13.69 Deliv.	\$13.00 pick/up
	Screened-\$17.69 Deliv.	\$16.30 pick/up
	Shredded-\$17.69 Deliv.	\$16.30 pick/up
Custom Topsoil, Inc. 320 Crabapple Lane Cheektowaga, NY 14227 716-668-4444	Regular - \$17.00 Deliv.	Inside Storage \$11.00 pick/up
	Screened-\$21.48 Deliv.	\$20.48 pick/up
	Shredded-\$21.48 Deliv.	\$20.48 pick/up
Leo Brenon Topsoi 5530 Killan Road Pendleton, NY 716-695-1000	Regular - \$16.45 Deliv.	\$14.45 pick/up
	Screened-\$18.45 Deliv.	\$16.45 pick/up
	Shredded-\$18.45 Deliv.	\$16.45 pick/up

RESULT: ADOPTED [UNANIMOUS]
MOVER: Jeff Swiatek, Councilmember
SECONDER: Mary Holtz, Supervisor
AYES: Holtz, Jaworowicz, Swiatek, Rogowski, Zydel, Markel, Kaznowski



20. RESOLUTION 2011-160

Award of Bid for Asbestos Survey - 24E Glenwood Court

Sponsored By: Councilmember Markel, Councilmember Kaznowski

WHEREAS, pursuant to the Unsafe Buildings Law of the Town of Cheektowaga, this Town Board can require that unsafe buildings be either repaired or demolished, and

WHEREAS, the building located at 24E Glenwood Court has experienced extensive deterioration and damage, and Nussbaumer & Clarke, Inc. determined that said building is unsafe and recommended that such building be demolished and removed, and

WHEREAS, by resolution dated January 18, 2011 (#2011-43) this Town Board ordered that the building located at 24E Glenwood Court either repaired or demolished, and directed that the owners or others responsible for the building commence said repair or demolition work within 30 days, and

WHEREAS, more than 30 days have expired and no work has been commenced with respect to 24E Glenwood Court, and

WHEREAS, pursuant to the Unsafe Buildings Law, this Town Board can provide for the demolition of an unsafe building and assess the cost of same against the property, and

WHEREAS, prior to the demolition of 24E Glenwood Court, the Town needs to retain a firm to perform an asbestos survey and asbestos abatement plan for same, and

WHEREAS, this Town Board issued a Notice to Bidders to various asbestos abatement firms and, based on proposals submitted, the Town Attorney has recommended that this Town Board retain 56 Services, Inc. at the total flat fee of \$1,830.00 to perform said asbestos survey, specifications and project monitoring work with respect to 24E Glenwood Court, NOW, THEREFORE, BE IT

RESOLVED, that this Town Board hereby retains 56 Services, Inc., P.O. Box 561, Buffalo, New York 14213 to perform the necessary asbestos survey and abatement work (if necessary) for 24E Glenwood Court at the cost listed above, and BE IT FURTHER

RESOLVED, that the Supervisor be and hereby is directed to execute an agreement with 56 Services, Inc. for said services, and BE IT FURTHER

RESOLVED, that moneys for said services shall be appropriated from budget line item number 0800-800-0440.

RESULT:	ADOPTED [UNANIMOUS]
MOVER:	Charles Markel, Councilmember
SECONDER:	Stanley Kaznowski, Councilmember
AYES:	Holtz, Jaworowicz, Swiatek, Rogowski, Zydel, Markel, Kaznowski



21. RESOLUTION 2011-161

Award of Bid for Asbestos Survey - 27 Alpine Place

Sponsored By: Councilmember Markel, Councilmember Kaznowski

WHEREAS, pursuant to the Unsafe Buildings Law of the Town of Cheektowaga, this Town Board can require that unsafe buildings be either repaired or demolished, and

WHEREAS, the building located at 27 Alpine Place has experienced extensive deterioration and damage, and Nussbaumer & Clarke, Inc. determined that said building is unsafe and recommended that such building be demolished and removed, and

WHEREAS, by resolution dated January 18, 2011 (#2011-45) this Town Board ordered that the building located at 27 Alpine Place be either repaired or demolished, and directed that the owners or others responsible for the building commence said repair or demolition work within 30 days, and

WHEREAS, more than 30 days have expired and no work has been commenced with respect to 27 Alpine Place, and

WHEREAS, pursuant to the Unsafe Buildings Law, this Town Board can provide for the demolition of an unsafe building and assess the cost of same against the property, and

WHEREAS, prior to the demolition of 27 Alpine Place, the Town needs to retain a firm to perform an asbestos survey and asbestos abatement plan for same, and

WHEREAS, this Town Board issued a Notice to Bidders to various asbestos abatement firms and, based on proposals submitted, the Town Attorney has recommended that this Town Board retain 56 Services, Inc. at the total flat fee of \$1,400.00 to perform said asbestos survey, specifications and project monitoring work with respect to 27 Alpine Place, NOW, THEREFORE, BE IT

RESOLVED, that this Town Board hereby retains 56 Services, Inc., P.O. Box 561, Buffalo, New York 14213 to perform the necessary asbestos survey and abatement work (if necessary) for 27 Alpine Place at the cost listed above, and BE IT FURTHER

RESOLVED, that the Supervisor be and hereby is directed to execute an agreement with 56 Services, Inc. for said services, and BE IT FURTHER

RESOLVED, that moneys for said services shall be appropriated from budget line item number 0800-800-0440.

RESULT:	ADOPTED [UNANIMOUS]
MOVER:	Charles Markel, Councilmember
SECONDER:	Stanley Kaznowski, Councilmember
AYES:	Holtz, Jaworowicz, Swiatek, Rogowski, Zydel, Markel, Kaznowski



22. RESOLUTION 2011-162

Change Order No. 1 - (HVAC Work) Police & Court Building

Sponsored By: Supervisor Holtz, Councilmember Markel

WHEREAS, the contract for HVAC Work for the Police & Court Building Renovations and Addition was awarded by Town Board Resolution dated September 7, 2010 to MLP Plumbing & Mechanical, Inc., 3198 Union Road, Suite 300, Cheektowaga, New York 14227 in the amount of \$1,818,000.00, AND

WHEREAS, the project architect, Trautman Associates, and the Town Engineer have recommended the approval of Change Order No. 1 (HVAC Work) which provides for an addition to the original contract amount as further outlined on the change order documents, NOW, THEREFORE, BE IT

RESOLVED, that Change Order No. 1 (HVAC Work) for the Police and Court Building Renovations and Addition, in the amount of \$5,575.00 as an addition to the contract of MLP Plumbing & Mechanical, Inc., be and hereby is approved, AND, BE IT FURTHER

RESOLVED, that the Supervisor is hereby authorized and directed to execute said change order document on behalf of this Town Board, chargeable to Account #500-1440-2528-5025.

RESULT:	ADOPTED [UNANIMOUS]
MOVER:	Mary Holtz, Supervisor
SECONDER:	Charles Markel, Councilmember
AYES:	Holtz, Jaworowicz, Swiatek, Rogowski, Zydel, Markel, Kaznowski



23. RESOLUTION 2011-163

Change Order No. 1 (Final) Electrical Work at the Anna Reinstein Memorial Library

Sponsored By: Councilmember Rogowski, Supervisor Holtz

WHEREAS, the contract for Electrical Work at the Anna Reinstein Memorial Library was awarded by Town Board Resolution dated September 1, 2009 to Industrial Power & Lighting Corporation in the amount of \$83,900.00, AND

WHEREAS, Trautman Associates, Project Architect, and the Town Engineer have advised that work under the aforesaid contract has been completed in accordance with the contract requirements and further recommends the approval of Change Order No. 1 (final) which provides for a credit to the contract as further outlined in the Change Order Document, NOW, THEREFORE, BE IT

RESOLVED, that this Town Board hereby accepts the completed project and directs the Supervisor to execute the final contract acceptance documents with Industrial Power & Lighting Corporation, 701 Seneca Street, Buffalo, New York 14210, including Change Order No. 1 (final) which provides for a credit to the aforesaid contract in the amount of \$543.00.

RESULT:	ADOPTED [UNANIMOUS]
MOVER:	James Rogowski, Councilmember
SECONDER:	Mary Holtz, Supervisor
AYES:	Holtz, Jaworowicz, Swiatek, Rogowski, Zydel, Markel, Kaznowski



24. RESOLUTION 2011-164

Niagara Frontier Radio Reading Service Recognized for "200,000 Hours of Radio Readings to the Blind" Broadcast Milestone

Sponsored By: Markel, Rogowski, Swiatek, Holtz, Jaworowicz, Zydel, Kaznowski

WHEREAS, many thousands of individuals throughout the Western New York area are print-handicapped and thus unable to read the newspapers, books and magazines that most of us take for granted; and

WHEREAS, the Niagara Frontier Radio Reading Service, a non-profit agency, with studios located at 1199 Harlem Road, in Cheektowaga, has given the blind a chance to read every day since 1987; and

WHEREAS, the dedicated volunteers of the Niagara Frontier Radio Reading Service have broadcast daily "radio readings" of printed matter to blind and print-handicapped Western New Yorkers, who are provided special "reading radios"; and

WHEREAS, for more than a generation, the remarkable Niagara Frontier Radio Reading Service has "opened the eyes" of those without sight to the information, enlightenment and entertainment that daily access to printed matter can bring; and

WHEREAS, on April 10, 2011, the Niagara Frontier Radio Reading Service, its volunteers and supporters will reach the milestone of broadcasting 200,000 Hours of Radio Readings to appreciative blind and print-handicapped listeners; NOW, THEREFORE, BE IT

RESOLVED, that the Cheektowaga Town Board recognizes the Niagara Frontier Radio Reading Service as it nears the 200,000 Hours of Radio Readings Milestone, on April 10, 2011, and urges all Town residents to join in saluting its dedicated volunteers and supporters for their selfless attention in helping others and improving the quality of life for our blind and print-handicapped residents.

RESULT:	ADOPTED [UNANIMOUS]
MOVER:	Charles Markel, Councilmember
SECONDER:	James Rogowski, Councilmember
AYES:	Holtz, Jaworowicz, Swiatek, Rogowski, Zydel, Markel, Kaznowski



25. RESOLUTION 2011-165

Special Event - Infant of Prague Church 5K Race

Sponsored By: Councilmember Rogowski, Councilmember Zydel

WHEREAS, by resolution dated May 1, 1995, this Town Board adopted a Special Events policy, which requires anyone wishing to hold a special event in the Town to file an application and supporting documentation, fees, etc. to the Town Clerk prior to the special event, AND

WHEREAS, Infant of Prague Church has made application to hold its "Feel the Spirit" 5K Run on Saturday, April 16, 2011 beginning at 11:00 A.M. for approximately forty minutes along the following route: Foisset, Mapleview, Yeager, Union, Clearvale, Beach, Huth, Burdette; AND

WHEREAS, this Board has reviewed the aforementioned application, which application has been approved by the Police Department, Highway Department and the Facilities Department, and has no objection to same, AND

WHEREAS, due to the nature of the event, this Town Board hereby waives the following requirements:

- 1) Submittal of plan for sanitary facilities;
- 2) Submittal of site plan;
- 3) Requirement that application be made at least 60 days prior to the date of the special event;
- 4) Submittal of Security Plan;
- 5) Submittal of Fire Prevention/Emergency Services Plan; NOW, THEREFORE, BE

IT

RESOLVED, that this Town Board hereby approves the aforementioned application of Infant of Prague Church for the said 5K Race on Saturday, April 16, 2011 beginning at 11:00 a.m.; AND BE IT FURTHER

RESOLVED, that the Chief of Police be and hereby is directed to provide traffic safety and escort services for such run and to ensure compliance with Section 1600(a)(6) of the Vehicle and Traffic Law; AND BE IT FURTHER

RESOLVED, that the Town Clerk shall forward a copy of this resolution to the Chief of Police Dave Zack.

RESULT:	ADOPTED [UNANIMOUS]
MOVER:	James Rogowski, Councilmember
SECONDER:	Richard Zydel, Councilmember
AYES:	Holtz, Jaworowicz, Swiatek, Rogowski, Zydel, Markel, Kaznowski



26. RESOLUTION 2011-166

Special Event - Villa Maria College 50Th Anniversary Walk

Sponsored By: Supervisor Holtz, Councilmember Rogowski

WHEREAS, by resolution dated May 1, 1995, this Town Board adopted a Special Events policy, which requires anyone wishing to hold a special event in the Town to file an application and supporting documentation, fees, etc. to the Town Clerk prior to the special event, AND

WHEREAS, Villa Maria College has made application to hold a 3.5 K Walk to celebrate their 50th Anniversary on Saturday, April 30, 2011 beginning at 10:00 a.m, starting on Pine Ridge Road, through Town Park and back to the College Campus, AND

WHEREAS, this Board has reviewed the aforementioned application, which application has been approved by the Police Department, Highway Department and the Facilities Department , and has no objection to same, AND

WHEREAS, due to the nature of the event, this Town Board hereby waives the following requirements:

- 1) Submittal of plan for sanitary facilities;
- 2) Submittal of site plan;
- 3) Requirement that application be made at least 60 days prior to the date of the special event;
- 4) Submittal of Security Plan;
- 5) Submittal of Fire Prevention/Emergency Services Plan; NOW, THEREFORE, BE

IT

RESOLVED, that this Town Board hereby approves the aforementioned application of Villa Maria College to hold a 3.5K Walk to celebrate their 50th Anniversary on Saturday, April 30, 2011 beginning at 10:00 a.m.; AND BE IT FURTHER

RESOLVED, that the Chief of Police be and hereby is directed to provide traffic safety and escort services for such run and to ensure compliance with Section 1600(a)(6) of the Vehicle and Traffic Law; AND BE IT FURTHER

RESOLVED, that the Town Clerk shall forward a copy of this resolution to the Chief of Police Dave Zack.

RESULT:	ADOPTED [UNANIMOUS]
MOVER:	Mary Holtz, Supervisor
SECONDER:	James Rogowski, Councilmember
AYES:	Holtz, Jaworowicz, Swiatek, Rogowski, Zydel, Markel, Kaznowski



27. RESOLUTION 2011-167

Authorize Supervisor to Execute Agreement with USDA for Geese Control

Sponsored By: Councilmember Rogowski, Councilmember Kaznowski

WHEREAS, the Town of Cheektowaga is experiencing a problem with Canadian Geese in Stiglmeier Park and other areas in the Town, and

WHEREAS, the U.S. Department of Agriculture, Wildlife Services Division ("USDA"), administers a Canada Goose Management Program in certain areas of the United States; in the State of New York, the USDA works in coordination with the New York State Department of Environmental Conservation, and

WHEREAS, prior to implementation of this program, the USDA, pursuant to the National Environmental Policy Act ("NEPA"), prepared an environmental assessment and issued a Decision of Finding of No Significant Impact, and

WHEREAS, the Town of Cheektowaga Facilities Department submitted an application for funding and authorization of a Canada Goose Management Program administered by the USDA on lands owned and/or controlled by the Town of Cheektowaga, and on private lands with landowner permission for 2011, and

WHEREAS, the Town Environmental Advisory Committee previously reviewed this application and its impact on the Town and recommended that a determination of non-significance be issued for this program, and this Town Board rendered a Determination of Non Significance for same, and

WHEREAS, the USDA requires that anyone wishing to have the USDA implement this program on their behalf execute an agreement with the USDA and commit to remit payment to the USDA for this program, and

WHEREAS, the cost of the program proposed for the Town of Cheektowaga is approximately \$4,985.00, and

WHEREAS, this Board wishes to proceed with utilizing the services of the USDA to operate the Canada Goose Management Program for the Town of Cheektowaga in 2011, NOW, THEREFORE, BE IT

RESOLVED, that, subject to review and approval by the Town Attorney's Office, the Supervisor be and hereby is authorized and directed to execute an agreement with the USDA and all other documents necessary to authorize the USDA to administer its Canada Goose Management Program for the Town of Cheektowaga, and BE IT FURTHER

RESOLVED, that moneys not to exceed \$4,985.00 for this program, shall be appropriated from budget line item number 100-7110-4106.

RESULT: ADOPTED [UNANIMOUS]

MOVER: James Rogowski, Councilmember
SECONDER: Stanley Kaznowski, Councilmember
AYES: Holtz, Jaworowicz, Swiatek, Rogowski, Zydel, Markel, Kaznowski



28. RESOLUTION 2011-168

Approve Cultural Group Funding for Cheektowaga Patriotic Commission & Cheektowaga Symphony Orchestra

Sponsored By: Supervisor Holtz, Councilmember Rogowski

WHEREAS, the Town, in its 2011 budget, allocated moneys to certain cultural and not-for-profit organizations which are involved in activities which benefit the Town, and

WHEREAS, agreement(s) between the Town and these cultural and not-for-profit organizations have been prepared and forwarded to such groups, and

WHEREAS, the organization(s) listed below have completed and returned signed agreement(s) and their accounting report(s) from the 2010 funding to the Town, NOW, THEREFORE, BE IT

RESOLVED, that this Town Board hereby approves agreement(s) with the cultural and not-for-profit organization(s) listed below for the amount(s) listed, and BE IT FURTHER

RESOLVED, that the Supervisor be and hereby is authorized and directed to execute agreement(s) with the following referenced cultural and not-for-profit organization(s) for the following respective amount(s):

<u>Cultural/Not-For-Profit Organization</u>	<u>Funding Approved</u>
Cheektowaga Patriotic Commission, Inc.	\$16,500.00
Cheektowaga Symphony Orchestra,	\$15,000.00

and BE IT FURTHER

RESOLVED, that the aforementioned moneys shall be paid to the respective cultural/not-for-profit organization(s) out of the respective cultural group budget line item(s) in the 2011 Town budget, subject to audit and approval of a properly signed Town voucher.

RESULT:	ADOPTED [UNANIMOUS]
MOVER:	Mary Holtz, Supervisor
SECONDER:	James Rogowski, Councilmember
AYES:	Holtz, Jaworowicz, Swiatek, Rogowski, Zydel, Markel, Kaznowski



29. RESOLUTION 2011-169

Agreement for Lead Hazard Testing Services

Sponsored By: Councilmember Markel, Councilmember Kaznowski

WHEREAS, testing and analysis of painted surfaces for lead hazards for housing rehabilitation projects is required by federal regulations, and

WHEREAS, the Town Office of Community Development previously solicited proposals from companies possessing the necessary certifications issued by the Environmental Protection Agency to provide necessary lead-based paint hazard testing and consulting services, and

WHEREAS, the Director of Community Development has recommended that the Town engage the services of Stohl Environmental, LLC, to perform the necessary lead hazard testing and consulting services, Now Therefore Be It

RESOLVED, that the Supervisor is hereby authorized and directed to execute an agreement for an amount not to exceed \$ 15,000 with Stohl Environmental, LLC, 4169 Allendale Parkway, Suite 100, Blasdell, New York 14219 to perform necessary lead hazard testing and consulting services for the Town of Cheektowaga pursuant to said company=s proposal dated May 7, 2010.

RESULT:	ADOPTED [UNANIMOUS]
MOVER:	Charles Markel, Councilmember
SECONDER:	Stanley Kaznowski, Councilmember
AYES:	Holtz, Jaworowicz, Swiatek, Rogowski, Zydel, Markel, Kaznowski



30. RESOLUTION 2011-170

Termination of Agreement with Upper New York Environmental

Sponsored By: Councilmember Markel, Councilmember Kaznowski

WHEREAS, an agreement with Upper New York Environmental was approved by the Town Board on June 7, 2010 and an agreement executed with said agency, and

WHEREAS, "Section 5-Response Time" of the Agreement between the Town and Upper New York Environmental allows for termination of said agreement if response time timetables are not substantially met, and

WHEREAS, Upper New York Environmental has not met the response time tables, and

WHEREAS, the Director of Community Development has recommended termination of said agreement with Upper New York Environmental, Now Therefore Be It

RESOLVED, that the aforementioned agreement with Upper New York State Environmental, 346 Austin Street, Buffalo, New York 14207 be and hereby is terminated effective immediately.

RESULT:	ADOPTED [UNANIMOUS]
MOVER:	Charles Markel, Councilmember
SECONDER:	Stanley Kaznowski, Councilmember
AYES:	Holtz, Jaworowicz, Swiatek, Rogowski, Zydel, Markel, Kaznowski



31. RESOLUTION 2011-171

Records Management Consultant

Sponsored By: Supervisor Holtz, Councilmember Swiatek

WHEREAS, the Town was awarded a State Archives grant which enabled the Town to engage the services of a Records Management Consultant; and

WHEREAS, the consultant will be retained to review the Town's electronic records with the Municipal Records Manager, conduct an on-site assessment, and produce a final report needs assessment containing recommendations for managing electronic records; and

WHEREAS, David O. Stephens of Zasio Enterprises Inc. Records & Document Management Experts is qualified to perform said services and wishes to do so under the terms of the State Archives Grant and an agreement of the Town; and

WHEREAS, the fees for consultant services are not to exceed \$30,000 and shall be appropriated from the State Archives Grant budget line number 100-1415-4001-1001, NOW THEREFORE BE IT

RESOLVED, that this Town Board hereby retains the services of David O. Stephens of Zasio as consultant to perform the duties of Electronic Records Management Consultant, in accordance with the terms and conditions of the attached agreement and the State Archives Local Government Records Management Improvement Fund Grant, and BE IT FURTHER

RESOLVED, that the Supervisor is authorized and directed to execute said agreement with Zasio Enterprises, Inc.

Attachments:

Zasio-Town of Cheektowaga (PDF)

Zasio Proposal Rev 15 Feb 2011 (2) (PDF)

RESULT: ADOPTED [UNANIMOUS]

MOVER: Mary Holtz, Supervisor

SECONDER: Jeff Swiatek, Councilmember

AYES: Holtz, Jaworowicz, Swiatek, Rogowski, Zydel, Markel, Kaznowski



32. RESOLUTION 2011-172

Authorization of Student Intern (Justice Court/Bridget Martin)

Sponsored By: Councilmember Jaworowicz, Councilmember Swiatek

WHEREAS, Bridget Martin, a student at Bryant & Stratton College has requested to participate in the student internship program at the Cheektowaga Justice Court; AND

WHEREAS, Ms. Martin has been interviewed by the Justice Court and the Court is willing to afford her the opportunity to intern in the Court; NOW, THEREFORE, BE IT

RESOLVED, that Bridget Martin of Buffalo, New York be and hereby is authorized to participate as an unpaid intern in the Cheektowaga Justice Court, subject to her execution of a Waiver of Liability and Agreement of Confidentiality; AND, BE IT FURTHER

RESOLVED, that the Town Supervisor be and hereby is authorized and directed to execute the Agreement of Confidentiality, and all other documents necessary to effectuate this student internship in the Justice Court effective March 8, 2011 through April 15, 2011.

RESULT:	ADOPTED [UNANIMOUS]
MOVER:	Patricia Jaworowicz, Councilmember
SECONDER:	Jeff Swiatek, Councilmember
AYES:	Holtz, Jaworowicz, Swiatek, Rogowski, Zydel, Markel, Kaznowski



33. RESOLUTION 2011-173

Youth & Recreation Hire

Sponsored By: Councilmember Zydel, Councilmember Rogowski

BE IT RESOLVED that the individuals listed below be and hereby are hired and/or transferred, as indicated, in the Department of Youth & Recreational Services, effective immediately:

Recreation Attendant - 7140.1640 - \$7.25
Regular Part-time

Anthony Overfield 14211

Regular Part-time
Recreation Attendant - 7140.1636 - \$7.40

Andrew Deeds

Recreation Attendant - 7140.1636 - \$7.55

Adam Barrett

Recreation Attendant - 7140.1636 - \$8.15

Christie Petre

Recreation Attendant - 7140.1640 - \$7.40

Dan Wasielewski

Recreation Attendant - 7140.1611 - \$7.65

Joseph Bodkin

Recreation Attendant - 7140.1611 - \$7.50

Eric Fiorello

Recreation Attendant - 7140.1611 - \$7.90

Liza Fiorello

Recreation Attendant - 7140.1611 - \$7.50

Jordan Kilijanski

Recreation Attendant - 7140.1640 - \$7.50

Corinne Monette

Recreation Attendant - 7140.1611 - \$7.90

Jayson Selbert

Motion by Supervisor Holtz; Seconded by Councilmember Rogowski to Waive the Reading of Names for the following Two (2) Resolutions. 2011-173 and 2011-174. Motion Carried.

RESULT: **ADOPTED [UNANIMOUS]**
MOVER: Richard Zydel, Councilmember
SECONDER: James Rogowski, Councilmember
AYES: Holtz, Jaworowicz, Swiatek, Rogowski, Zydel, Markel, Kaznowski



34. RESOLUTION 2011-174

Hiring/Termination of Part-Time/Seasonal Employees

Sponsored By: Councilmember Swiatek, Supervisor Holtz

BE IT RESOLVED, that the following individuals be and hereby are hired as **PART-TIME EMPLOYEES** in the departments listed, not to exceed nineteen (19) hours on a weekly basis, in compliance with Civil Service Laws and Regulations as well as the provisions of the Town's collective bargaining agreement between the Town of Cheektowaga and the Town of Cheektowaga Employees Association:

FACILITIES DEPARTMENT (Buildings & Grounds Division) Laborer \$8.00/hour effective 3/22/11

William W. Lauber, Cheektowaga, New York

SENIOR SERVICES Recreation Attendant (Substitute Ceramics Instructor) \$9.25/hour effective 3/22/11

Catherine M. Albee, Depew, New York

BE IT RESOLVED, that the following seasonal and/or part-time employees be and hereby are terminated as listed:

SANITATION DEPARTMENT

Suzanne Bolger effective 3/5/11

JUSTICE COURT

Molly Platt effective 3/26/11

RESULT:	ADOPTED [UNANIMOUS]
MOVER:	Jeff Swiatek, Councilmember
SECONDER:	Mary Holtz, Supervisor
AYES:	Holtz, Jaworowicz, Swiatek, Rogowski, Zydel, Markel, Kaznowski



35. RESOLUTION 2011-175

Appointment of CEDC Directors

Sponsored By: Councilmember Swiatek, Supervisor Holtz

WHEREAS, the Town Board of the Town of Cheektowaga previously created the Cheektowaga Economic Development Corporation for the purpose of assisting and encouraging economic development within the Town, and

WHEREAS, By Resolution dated February 7, 1983 this Town Board approved the By-Laws of the Cheektowaga Economic Development Corporation which provide that the Directors of the Cheektowaga Economic Development Corporation be appointed by resolution of the Cheektowaga Town Board, and

WHEREAS, the Directors of the Cheektowaga Economic Development Corporation have recommended the appointment of the individuals listed below to the Board of Directors of the Cheektowaga Economic Development Corporation, NOW, THEREFORE, BE IT

RESOLVED, that the following individuals are hereby appointed to the Board of Directors of the Cheektowaga Economic Development Corporation, effective immediately for a term of three years, said term expiring at the time of reappointment to said Board of Directors positions but no later than June 30, 2013:

- Robert Pietrzak
- Samuel Tadio
- Debra Liegl
- Timothy Popielski
- Donna Luh.

RESULT:	ADOPTED [UNANIMOUS]
MOVER:	Jeff Swiatek, Councilmember
SECONDER:	Mary Holtz, Supervisor
AYES:	Holtz, Jaworowicz, Swiatek, Rogowski, Zydel, Markel, Kaznowski

**36. RESOLUTION 2011-176****Appointment of Senior Engineer Assistant
(Competitive/Provisional) Engineering Department/Gail
Milburth**

Sponsored By: Councilmember Swiatek, Supervisor Holtz

WHEREAS, a provisional vacancy exists in the title of Senior Engineer Assistant in the Engineering Department; AND

WHEREAS, said vacancy was posted in compliance with the bargaining agreement between the Town and the Town of Cheektowaga Employees Association; AND

WHEREAS, Gail Milburth, currently employed as an Assistant Code Enforcement Officer in Community and Economic Development, bid on said vacancy and meets the qualifications for provisional appointment; NOW, THEREFORE, BE IT

RESOLVED, that Gail Milburth of Cheektowaga, New York be and hereby is appointed the provisional position of Senior Engineer Assistant in the Engineering Department in compliance with the terms and conditions of the collective bargaining agreement between the Town and the Town of Cheektowaga Employees Association effective March 28, 2011.

RESULT:	ADOPTED [UNANIMOUS]
MOVER:	Jeff Swiatek, Councilmember
SECONDER:	Mary Holtz, Supervisor
AYES:	Holtz, Jaworowicz, Swiatek, Rogowski, Zydel, Markel, Kaznowski

**37. RESOLUTION 2011-177****Appointment of Park Maintenance Worker I
(Labor/Permanent) Facilities Department (Parks
Division)/Scott R. Fullington**

Sponsored By: Councilmember Swiatek, Supervisor Holtz

WHEREAS, a vacancy exists in the title of Park Maintenance Worker I in the Facilities Department (Parks Division); AND

WHEREAS, notice of said vacancy has been posted in accordance with the provisions of the Town's collective bargaining agreement with the Town of Cheektowaga Employees Association; AND

WHEREAS, no full-time bargaining unit bid on said vacancy; AND

WHEREAS, Scott R. Fullington of Cheektowaga, New York, currently employed as a temporary General Mechanic in the Department, applied for said position and meets the necessary qualifications for appointment; NOW, THEREFORE, BE IT

RESOLVED, that Scott R. Fullington of Cheektowaga, New York, be and hereby is appointed to the position of Park Maintenance Worker I in the Facilities Department (Parks Division) in accordance with the terms and conditions of the Town's collective bargaining agreement with the Town of Cheektowaga Employees Association effective March 22, 2011.

RESULT:	ADOPTED [UNANIMOUS]
MOVER:	Jeff Swiatek, Councilmember
SECONDER:	Mary Holtz, Supervisor
AYES:	Holtz, Jaworowicz, Swiatek, Rogowski, Zydel, Markel, Kaznowski

**38. RESOLUTION 2011-178**

Travel Authorization Community and Economic Development/Director of Community Development Jerome Gabryszak

Sponsored By: Councilmember Swiatek, Supervisor Holtz

WHEREAS, an Introduction to Environmental Review Procedure Training Workshop is being held March 23, 2011 in Albany, New York; AND

WHEREAS, Director of Community Development Jerome Gabryszak has requested authorization to attend said workshop; AND

WHEREAS, Mr. Gabryszak has submitted a request for travel authorization along with the proper paperwork in a timely manner; AND

WHEREAS, the total cost to the Town shall not exceed \$380.25; AND

WHEREAS, these expenses have been budgeted by Community Development; NOW, THEREFORE, BE IT

RESOLVED, that Director of Community Development Jerome Gabryszak be and hereby is authorized to attend the Introduction to Environmental Review Procedure Training Workshop being held March 23, 2011 in Albany, New York.

RESULT:	ADOPTED [UNANIMOUS]
MOVER:	Jeff Swiatek, Councilmember
SECONDER:	Mary Holtz, Supervisor
AYES:	Holtz, Jaworowicz, Swiatek, Rogowski, Zydel, Markel, Kaznowski



39. RESOLUTION 2011-179

Travel Authorization Police Department/Detective Mark Jedd

Sponsored By: Councilmember Jaworowicz, Councilmember Swiatek

WHEREAS, the Motor Vehicle Theft and Insurance Fraud Statewide Work Group will be meeting April 14 through April 15, 2011 in Albany, New York; AND

WHEREAS, Detective Mark Jedd has requested authorization to attend said meeting; AND

WHEREAS, Police Chief David Zack has submitted a request for travel authorization along with the proper paperwork in a timely manner; AND

WHEREAS, the total cost to the Town shall not exceed \$433.86; AND

WHEREAS, these expenses have been budgeted by the Police Department; NOW, THEREFORE, BE IT

RESOLVED, that Detective Mark Jedd be and hereby is authorized to attend the Motor Vehicle Theft and Insurance Fraud Statewide Work Group Meeting April 14 through April 15, 2011 in Albany, New York.

RESULT:	ADOPTED [UNANIMOUS]
MOVER:	Patricia Jaworowicz, Councilmember
SECONDER:	Jeff Swiatek, Councilmember
AYES:	Holtz, Jaworowicz, Swiatek, Rogowski, Zydel, Markel, Kaznowski

V. Suspension of Rules

Motion by Councilmember Markel; Seconded by Councilmember Rogowski to Waive the Rules to Include the Following One (1) Resolution - 2011-180. Motion Carried.



1. RESOLUTION 2011-180

Reappointment to Board of Ethics

Sponsored By: Councilmember Markel, Councilmember Swiatek

WHEREAS, the term of Eleanor Peinkofer as Member of the Board of Ethics expired on August 1, 2010, AND

WHEREAS, the Board of Ethics has recommended that Mrs. Peinkofer be reappointed to serve on the Board of Ethics for another term, AND

WHEREAS, Mrs. Peinkofer has expressed an interest in being reappointed to the Board of Ethics, NOW, THEREFORE, BE IT

RESOLVED, that Eleanor Peinkofer, of Cheektowaga, New York be and hereby is reappointed to the Board of Ethics, effective August 1, 2010 and expiring on August 1, 2015.

RESULT:	ADOPTED [UNANIMOUS]
MOVER:	Charles Markel, Councilmember
SECONDER:	Jeff Swiatek, Councilmember
AYES:	Holtz, Jaworowicz, Swiatek, Rogowski, Zydel, Markel, Kaznowski

VI. Communications

A. Departmental Communications

1. Supervisor's Statement of Funds - January 2011
2. Minutes: Cheektowaga Planning Board - February 10, 2011
3. Minutes: Town Environmental Advisory Committee - March 2, 2011

B. General Communications

1. Notice of Claim: Josephine Belcer Vs. Town of Cheektowaga
2. Notice of Claim: Christen Buchholtz, Individually and as Administratrix of the Estate of Justin Buchholtz and as Parent and Natural Guardian of the Unborn Child of Justin Buchholtz and Jessica D'Amico as Parent and Natural Guardian of Cheyanne Buchholtz Vs. Town of Cheektowaga
3. Notice of Claim: Michele DiPirro Vs. Town of Cheektowaga
4. Notice of Claim: Donnell G. Mueller Vs. Town of Cheektowaga
5. Notice of Claim: NGM Insurance Co A/S/O Richard A. Young Vs. Town of Cheektowaga

6. Notice of Claim: Anthony Rose Vs. Town of Cheektowaga
7. Notice of Claim: Tami & John Schaller Vs. Town of Cheektowaga
8. Notice of Claim: Carol Winiarski Vs. Town of Cheektowaga
9. Notice of Claim: Steven A. Wood Vs. Town of Cheektowaga

VII. Comments

A. Supervisor's Comments

B. Councilmember's Comments

C. Public Comments

VIII. Adjournment

Motion by Councilmember Swiatek; Seconded by Supervisor Holtz to Close the Meeting in Memory of Angeline Janicki, former employee of the Town Clerk's Office. Time of adjournment - 7:15 PM

Alice Magierski
Town Clerk

Zasio Enterprises, Inc. Consulting Services Agreement

This Consulting Services Agreement (hereinafter "Agreement") is entered into as of this 8th day of March, 2011, by and between Zasio Enterprises, Inc., having its principal place of business at 12601 W. Explorer Drive, Boise, ID 83713, (hereinafter "Zasio") and Town of Cheektowaga, having its principal place of business at 3301 Broadway, Cheektowaga, NY 14227 (hereinafter "Client") either or both of which may hereinafter be referred to as "party" or "parties."

WHEREAS, Client is desirous of receiving certain services and deliverables pertaining to records and information management, as specified in Attachment A; and

WHEREAS, Zasio is a provider of consulting services in records and information management; and

WHEREAS, Zasio submitted a proposal defining a scope of services, pricing and certain other terms and conditions for those services (Attachment A);

NOW, THEREFORE, Town of Cheektowaga and Zasio have entered into this agreement, effective as of March 22, 2011, the particulars of which are as follows:

1. Services. Zasio agrees to provide the services set forth in Attachment A.
2. Compensation. Client shall pay Zasio for the services in accordance with the payment terms set forth in Attachment A. Zasio shall invoice Client for all fees when due. Client shall pay all such invoices within thirty (30) days from the date of receipt thereof. Services performed outside of the specifications in Attachment A shall be agreed to in writing by both parties, and shall be billed at Zasio's standard rates.
3. Term. The term of this Agreement shall commence on its effective date and shall expire four months thereafter, unless Client and Zasio, by mutual consent, agree to its extension.
4. Services and Deliverables. Zasio represents and warrants that (a) services shall be supplied in a professional and highly skilled manner and to standards not less than those generally accepted in the industry and (b) deliverables shall conform to the specifications in Attachment A.
5. Confidential Information. Zasio shall not reproduce or disclose any information, knowledge, or data of Client that Zasio may receive or have access to, including proprietary or confidential information of Client. Zasio agrees not to

use any confidential information for any purpose except to perform the services under this Agreement.

6. Insurance. Zasio hereby represents that, during the term of this Agreement, it will maintain adequate insurance and limits. Certificates of insurance will be furnished to Client upon written request. Please see Attachment A: Certificate of Insurance for evidence of Zasio's insurance and limits.

7. Indemnification. Both parties agree to defend, indemnify and hold the other harmless from and against any and claims, losses, costs, including reasonable attorneys, damages or liabilities whatsoever arising from its breach of any of its obligations contained in this Agreement.

8. Assignment and Subcontracts. Neither party may sell, transfer, or assign its rights and duties under this Agreement without the prior written consent of the other party. Zasio may enter into subcontracts provided that any subcontract acknowledges the binding nature of this Agreement and incorporates this Agreement, including any attachments, with the written consent and approval of the Town.

9. Termination for Convenience. Both parties will have the right at any time to terminate this Agreement upon sixty (60) days advance written notice from terminating party, with or without cause. In the case of such a termination, Client shall pay Zasio for all services rendered through the effective date of termination.

10. Default. If either party shall be in default of this Agreement and such default shall continue for more than twenty (20) days after written notice thereof is given to the party in default, the party not in default shall be entitled to terminate this Agreement. The election to terminate shall not be construed to be an election of remedies or a waiver thereof, and the party not in default shall be entitled to each and every other remedy available to it at law and / or in equity. The failure to object to an act of default shall not be deemed a waiver thereof.

11. Limitation on Liability. In no event shall either party be liable to the other for either incidental or consequential damages that may result from the services and deliverables provided under this Agreement.

12. Force Majeure. Neither party shall be liable for any default of delay in the performance of its obligations under this Agreement due to any causes beyond its reasonable control, which causes include but are not limited to fire, flood, earthquake, elements of nature or acts of God, and of war, terrorism, riots, civil disorder, rebellions or revolutions in the United States. In such events, the non-performing party shall be excused from any further performance or observance of the obligation(s) so affected for as long as the circumstances prevail and such party continues to use commercially reasonable efforts to recommence performance or observance whenever and to whatever extent possible without undue delay. If any such default or delay extends for more than thirty (30) days,

either party shall have the right, without obligation or liability, to cancel this Agreement or portion thereof affected by such default or delay.

13. Successors. This Agreement shall inure to the benefit of and be binding upon the parties hereto and their successors and permitted assigns.

14. Compliance with Laws. Zasio shall comply with all relevant and applicable laws and regulations of the federal, state and local governments in connection with the services provided under this Agreement.

15. Notices and Consents. All notices and consents required to be given or made by the parties shall be sent to the addresses appearing below:

If to CLIENT NAME:

Town of Cheektowaga
 Mary F. Holtz
 Supervisor
 3301 Broadway
 716.686.3465
 716.686.3451
 mholtz@tocny.org

If to Zasio Enterprises, Inc.:

David O. Stephens, CRM, FAI
 Vice President, Records Management Consulting
 316 North Third Street
 Smithfield, NC 27577
 Phone: 208-375-8000 ext. 530
 Fax: 919-989-6453
 E-mail: dostephens@zasio.com

16. Entire Agreement / Amendments. This Agreement and any documents incorporated specifically by reference constitute the entire Agreement between the parties and supersede any and all prior oral or written statements or other representations. In the event there is a conflict between this Agreement and any documents attached hereto, the provisions of this Agreement shall prevail. This Agreement may be modified only by written amendments duly executed by Client and Zasio.

IN WITNESS WHEREOF, each party hereto has caused this Agreement to be executed by its duly authorized representatives.

Town of Cheektowaga

By: _____

Print name: _____

Title: _____

Date: _____

Zasio Enterprises, Inc.

By: Cindy Blair

Print name: Cindy Blair

Title: Contracts Admin.

Date: March 14, 2011

Attachment: Zasio-Town of Cheektowaga (RES-2011-171 : Records Management Consultant)

Proposal for:

Consulting Services in Electronic Records Management Planning

PRESENTED TO:

Town of Cheektowaga Cheektowaga, New York

PRESENTED BY:

Zasio Enterprises, Inc.

Boise, Idaho USA

This document was prepared by:

David O. Stephens, CRM, FAI

Senior Vice President

Zasio Enterprises, Inc.

Phone: +919.989.1106

E-mail: dostephens@zasio.com

Revised

February 15, 2011

This is a confidential document between the Town of Cheektowaga, NY and Zasio Enterprises, Inc. This document may not be distributed to any person or organization outside your organization without written permission from Zasio Enterprises, Inc.

ZASIO
RECORDS & DOCUMENT MANAGEMENT EXPERTS

Consulting
Records Management Consulting Services

Table of Contents

Part 1 – Introduction 1

Part 2 – Approach and Methodology 3

Part 3 – Qualifications and Experience 6

Part 4 – Client References 16

Proposed Project Pricing 18

Attachment: Zasio Proposal Rev 15 Feb 2011 (2) (RES-2011-171 : Records Management Consultant)

Part 1 – Introduction

Zasio Enterprises, Inc. and its Records Management Consulting Division are pleased to present this proposal to the Town of Cheektowaga, New York (hereinafter referred to as “the Town”). This proposal is to conduct a comprehensive Needs Assessment and Strategic Plan for the enterprise-wide management of the Town’s electronic records, which are currently being generated in or maintained by thirty-two departments. The Town reports that, to date, there has been no management of electronic records in accordance with State Archives standards. This project is intended to provide recommended best practices to fill this gap.

As background to this proposal, in its Request for Proposals, the Town states that, although most departments adhere to standard records management policies and procedures for paper records, the Town does not have policies and procedures in place for the management of electronic records. Ultimately, the Town’s goal is to manage electronic data, regardless of the environment/software programs, in order to follow records management guidelines and meet the requirements of the life cycle of a record. This proposal is responsive to these requirements.

The Management of Public Records: Zasio’s Operating Philosophy

In proposing the work described herein, we think it is important to share our operating philosophy with the Town concerning the management of local government records, which can best be summarized by the following statement:

Public records are public property. They are held in trust for the sole benefit of the citizens of their jurisdictions. Public records may not be sold, given away, destroyed, or alienated from official custody except through an official act of the governing authority in accordance with provisions of any state law relating to their care and disposition. As public property, public records may no more be altered, defaced, mutilated or removed from custody that public funds may be embezzled or misappropriated. Indeed, because public records document the conduct of the public’s business – including the protection of rights, privileges, property and other assets, and because of the intrinsic uniqueness and irreplaceability of their content – they constitute a species of public property of a higher value than buildings, equipment or even money. It is for these reasons that the judicious management of public records is of supreme importance in the conduct of the public’s business by any agency of government.

The foregoing was adapted from *Local Government Records: An Introduction to Their Management, Preservation and Use*, by H.G. Jones (American Association for State and Local History, 1980). During his tenure as State Archivist of North Carolina, Dr. Jones trained David Stephens, who is proposed as Project Manager for the Cheektowaga project as proposed herein.

In the sections that follow, we will detail our technical approach and methodology for accomplishing these tasks, as well as our professional qualifications and experience. We wish to thank the Town of Cheektowaga in advance for its consideration of this proposal and our firm.

Zasio Enterprises, Inc.
Boise, Idaho USA

Part 2 – Approach and Methodology

In this section, the Zasio Consultants will detail our proposed methodology for accomplishing the several tasks associated with this project. We propose five major tasks, as follows:

- Task 1 – Conduct Survey of Town Electronic Recordkeeping Systems
- Task 2 – Analyze Data and Prepare Recommendations
- Task 3 – Prepare Interim Draft / Final Reports
- Task 4 – Present Findings and Recommendations to Town
- Task 5 – Assist with Town Grant Application

These tasks are described as follows:

Task 1 – Conduct Survey of Town Electronic Recordkeeping Systems

In this task, the Zasio Consultants will work cooperatively with the Town’s team of key project stakeholders, to include the Town Clerk, the Municipal Records Manager, the Network Coordinator, and key department heads. We propose to conduct a survey of the recordkeeping systems of the Town’s administrative and operating departments. From the Town’s website, these include:

- Accounting / Payroll
- Animal Control
- Assessors Office
- Attorney’s Office
- Building and Plumbing Department
- Fire Safety Office
- Central Records Management Department
- Community Development
- Council Office
- DARE Drug Abuse Resistance Education
- Emergency Services
- Employee Relations
- Engineering
- Facilities – Parks Division & Buildings and Grounds Division
- Highway
- Housing and Neighborhood Preservation
- Information Support Services
- Justice Court
- Police Department / Traffic Management
- Sanitation Department

- Senior Services
- Sewer Department
- Supervisor's Office
- Tax Office
- Town Clerk's Office
- Youth and Recreational Services

We propose to survey the status of electronic records in these departments by a combination of three methods:

- Onsite interviews with selected departmental officials
- Remote interviews with selected department officials via phone conference calls
- Remote surveys via questionnaire with selected departments

Working with Cheektowaga's project coordinator, the Zasio Consultants will determine the optimal method of data gathering for each department. We will then proceed to conduct the onsite interviews, followed by the remote conference calls and questionnaire surveys.

Following completion of this data gathering tasks, we will review the current technological environment with the project team and then proceed to analyze all collected data and prepare our findings and recommendations, as described below.

Task 2 – Analyze Data and Prepare Recommendations

In this task, the Zasio Consultants will analyze the information gathered during the preceding task. We will develop recommended solutions for the improved management of the Town's electronic records, to include a recommended and an alternative approach. The recommendations will include flow charts depicting the current and proposed systems and methods, as well as a detailed plan of work. Items to be addressed in this Needs Assessment include the following:

- Electronic Records Catalog (including records types, owner, date, size, location)
- Paper Reduction
- E-mail Archiving
- Electronic Approval Processes
- Document Enabling Existing Systems
- Near-line Central Records Repository
- FOIL Compliance
- Migrating Legacy Electronic Records
- Electronic Time Sheets
- eMail Presentment
- eDiscovery Capabilities
- Staff Training

- Implementation Costs
- Possible need to new software
- Recommended Policies and Procedures
- Retention and Disposition of Electronic Records

Task 3 – Prepare Interim Draft / Final Reports

In this task, the Zasio Consultants will prepare an interim report of our findings and recommendations, which will be presented to the Town for review. We will then make any and all reasonable revisions as requested by the Town and then submit a final report. This will be utilized as a guide to incorporating systems that will greatly enhance the Town’s electronic records management environment. The final report will be submitted in PDF format; four paper copies will also be submitted.

Task 4 – Present Findings and Recommendations to Town

In this task, the Zasio Consultants will present our major findings and recommendations to any group of Town officials as may benefit from such presentation.

Task 5 -- Assist Town with Grant Application

In this task, the Zasio Consultants will assist the town in preparing grant applications to obtain LGRMIF support to fund recommendations presented in the project report.

Part 3 – Qualifications and Experience

In this section, the Zasio Consultants will present in detail our capabilities to satisfy the requirements of this project. We will present a summary of our company and its organizational resources in records management, the technical expertise of our proposed project consultants, our prior client experience, and references who may be contacted.

About Zasio Enterprises

Zasio Enterprises, Inc. is one of the nation’s leading records and information management software and consulting companies. Now in its twenty-third year, Mr. Kevin Zasio founded the firm in 1987. The company was originally based in San Jose, California, but it relocated its corporate operations to Boise, Idaho in 1993. The firm was founded based on one vision: *to provide organizations in both the public and private sector with an affordable computer software platform to enable them to establish total life cycle management and control over their records and information throughout the enterprise.*

Throughout the world, all organizations, whether large or small, public or private, have one thing in common: they all experience persistent problems with their recordkeeping systems. The mission of Zasio Enterprises, Inc. is, simply stated, to find answers to these problems. Our mission statement:

Information is competitive intelligence – a strategic asset of the enterprise. As one of the leading records management companies in the U. S., we seek to optimize the value of records and information on an enterprise-wide scale. We provide our clients with solutions to problems such as: How to manage the creation and growth of information, how to organize and index it for effective retrieval, whether and how to convert it to some type of non-paper medium, how to safeguard it against loss, and whether, when and how to destroy it.

Brief Description of Zasio’s Core Competencies

Zasio Enterprises, Inc. core competencies in the records management field are as follows:

- **Needs Assessments / Strategic Plans** – There is an old saying that if you don’t know where you’re going, any road will get you there! The first thing any organization needs when contemplating major initiatives in enterprise records management is a good long-range strategic plan. The main focus of these needs assessments is transitioning from paper-based to electronic recordkeeping capabilities. The resulting strategic plans are designed to provide a road map to guide the assimilation of a variety of new management initiatives and document technologies over a three- to five-year period. Our reports typically include an

executive summary and a section discussing the organization's current recordkeeping situation, its strengths and deficiencies, and its problems and needs.

- **Technology Solutions for Records Management** – The Zasio Consultants specialize in helping organizations assimilate various classes of technology solutions for records management. These include records management software, electronic document management / enterprise content management, electronic document imaging, content archiving, and others. We help our clients define the need for these solutions, prepare a solid business case for funding authorization, develop technical specifications and other components of an RFP for competitive procurement, evaluate submitted proposals, and develop plans and strategies for solution implementation.
- **Management of email and other unstructured content** – Under-management of unstructured records – email, fileshares, SharePoint sites, and other content created at the desktop level – is arguably the single biggest records management problem in the U.S. today. Our goal is to enhance our solutions for bring better management / retention to this key category of digital content.
- **Legal records management expertise** – Zasio Enterprises, Inc. utilizes both in-house and out-of-house legal/attorney expertise in its consulting engagements. We utilize outside counsel on a case-by-case basis, to resolve interpretative issues generated by our in-house consultants. We also have two in-house legal research specialists, one of whom is a licensed attorney; the other is JD-qualified.
- **Enterprise records retention schedules** – The retention schedules we develop provide maximum flexibility – they can be configured as global, functional schedules of various hierarchical levels, departmental schedules, or a hybrid of both. The retention periods are designed to comply with the law, meet the organization's business needs, and satisfy the key test of reasonableness and good faith. They are supported by thorough legal research for all relevant jurisdictions – U.S. domestic and overseas.

Zasio's Client Base: Governmental Clients

- **City of Boca Raton (Florida)** – The Zasio Consultants conducted an electronic document imaging assessment for this medium-sized Florida city. We conducted a comprehensive survey of the City's major recordkeeping systems, and then analyzed them to determine their suitability for conversion to imaging. We then developed systems specifications for imaging hardware and software and make other recommendations to enable the City to assimilate imaging technology.
- **City of New York, NY** – The Zasio Consultants conducted a strategic planning study for records management improvement in this, one of the world's largest cities. We conducted interviews and reviewed existing policies and procedures and related

documentation, in order to determine the current situation for records management, and to identify strengths and limitations. We then developed a long-range strategic plan with detailed recommendations for enhancing the quality of the City's records management initiatives to standards of best professional practice.

- **City of Tampa (Florida)** – The Zasio Consultants conducted an assessment of the City's existing records management capabilities, with emphasis on document imaging. We surveyed approximately fifteen mission-critical recordkeeping systems, all paper-based and vital, with no backup. We then developed recommendations for transitioning the City's microfilm-based imaging program to digital capabilities, and made many other recommendations designed to enhance the quality of records management and archival preservation.
- **Maricopa County (Arizona)** – The Zasio Consultants conducted an assessment of inactive records storage for this large urban county government (Phoenix). We surveyed the County's existing in-house and commercial records storage facilities, and developed recommendations designed to enhance the quality and optimize the cost of inactive records storage over the near and long-term.
- **Michigan State Archives** – The Zasio Consultants conducted an assessment of the current situation and made best practice recommendations in two key areas: electronic records retention and digital preservation.
- **Nebraska State Supreme Court** – The Zasio Consultants conducted an assessment to resolve problems associated with the management of the criminal case files of this court's largest entity (the court in Omaha, Nebraska). We surveyed the usage, storage, retrieval and other management aspects of these records and then developed recommendations for converting the files from paper-based to image format.
- **Panama Canal Commission** – Immediately prior to the transition in ownership and management from the United States to the Republic of Panama, the Zasio Consultants conducted training in various aspects of records and information management for this organization.
- **Pennsylvania Historical and Museum Commission** – The Zasio Consultants conducted a pilot project in one of the State's key agencies (the State Department of Health) to develop policies, processes and practices for scheduling electronic records for retention. We provided recommendations for applying the basic principles of records retention to records in electronic format, to enable records management analysts and archivists to perform this task on a state-wide basis.
- **San Bernardino County (California)** – The Zasio Consultants conducted a comprehensive analysis of archival and records management capabilities in this large

California county and developed a long-range plan for improvement. We studied the existing records storage situation, the current policies and procedures, the archival preservation capabilities, the staffing, and other aspects of recordkeeping, and made detailed recommendations for improvement.

Zasio's Client Base: Large, Multinational Firms

During the past fifteen years, Zasio Enterprises has developed enterprise records management / retention strategies and programs for multinational clients throughout the U.S. and abroad. A sample of these follows:

- Asian Development Bank, Manila, Philippines
- Bank of America, Charlotte, NC
- Boeing Company, Chicago, IL
- Caterpillar, Inc., Peoria, IL
- Chubb & Son, Warren, NJ
- Educational Testing Service, Princeton, NJ
- Electronic Data Systems, Plano, TX
- Eli Lilly, Indianapolis, IN
- Ford Motor Company, Dearborn, MI
- The Gap, San Francisco, CA
- GE Asset Management, Stamford, CT
- Gateway Computers, North Sioux City, SD
- General Motors Corporation, Detroit, MI
- Johnson & Johnson, New Brunswick, NJ
- Jumeirah Group, Dubai, United Arab Emirates
- Kellogg Company, Battle Creek, MI
- L-3 Communications Corp., New York, NY
- Mattel, Inc. El Segundo, CA
- Motorola, Schaumburg, IL
- Novo Nordisk, Copenhagen, Denmark
- Panama Canal Commission, Republic of Panama
- Temple-Inland Corporation, Austin, TX
- Turner Broadcasting Co., Atlanta, GA
- Verizon Communications, New York, NY
- Yamanouchi Pharmaceutical Co., Ltd., Tokyo, Japan

Proposed Project Consultants

Zasio Enterprises hereby proposes a team of four key consultants for this project. These consultants are listed below, together with a brief summary of their professional credentials. More extensive coverage of their professional credentials appears in their *curriculum vitae*,

which accompany this proposal. We propose the following senior / key members of our proposed consulting team:

Project Manager: David O. Stephens, CRM, EMC/S

David Stephens is an internationally recognized authority in the records and information management field. Since 1995, he has been vice president for records management consulting at Zasio Enterprises, Inc. Mr. Stephens has over thirty years of experience in the field and has developed or improved records management programs for more than two hundred corporations and government agencies throughout the United States. His most recent book is *Records Management: Making the Transition from Paper to Electronic* (ARMA International, 2007). He also co-authored the book *Electronic Records Retention: New Strategies for Data Life Cycle Management* (ARMA International, 2003), and *Electronic Records Management* (ICMA, 2006). He has spoken to thousands of records managers throughout the United States and in some twenty countries in Europe, Asia, Latin America and the South Pacific. Mr. Stephens is a Certified Records Manager, and in 1989-1990 served as President and CEO of ARMA International, a professional association representing over 10,000 records managers from some thirty-five countries throughout the world.

David O. Stephens, CRM, ECM/S: List of Governmental Clients

- City of Boca Raton, Florida
- City of New York, New York
- City of Tampa, Florida
- Maricopa County, Arizona
- Michigan State Archives
- Nebraska State Supreme Court
- Panama Canal Commission
- Pennsylvania Historical and Museum Commission
- San Bernardino County, California
- Town of Tonawanda, New York

Senior Consultant for Records Management Policy Planning: Dr. William Saffady

Bill Saffady is one of the foremost authorities on enterprise records management in the United States. He is the author of over 30 books and many articles on information management topics, including records management, electronic document imaging, information storage technologies, and library automation. Dr. Saffady's book *Managing Electronic Records* (ARMA International, the fourth edition is now being written) is considered the standard work on this subject. Some of his other books that are relevant to this proposal include *Electronic Document Imaging: Technology, Applications, Implementation* (2001), *Micrographics: Technology for the Twenty-First Century* (2000), *The Value of Records: the Business Case for Systematic Control of Recorded Information* (1999), and *Cost Analysis Concepts and Methods for Records*

Management Projects (1998), all of which were published in the indicated years by the Association of Records Managers and Administrators (ARMA International).

Dr. Saffady's consulting practice includes providing training and analytical services to corporations, government agencies, and other organizations throughout the United States. His client list includes the U. S. Central Intelligence Agency, the Federal Bureau of Investigation, the World Bank, the Inter-American Development Bank, General Motors Corporation, the Museum of Modern Art, and many others.

William Saffady, PhD: Listing of LGRMIF Grant Clients

Dr. Saffady has provided consulting services for LGRMIF recipients since the inception of the grant program. Within the last 10 years, Dr. Saffady has completed needs assessments and other consulting assignments funded by LGRMIF grants for the following New York State local governments:

- Town of Guilderland (1998): analysis of four town departments: Assessor, Building Inspector, Planning and Zoning, and Town Engineer. Recommendations were funded by the New York State Archives in the 1999-2000 grant cycle.
- Town of Greenburgh (1998): analysis of methods for management of computer printouts. Recommendations were fully funded by the New York State Archives in the 1999-2000 grant cycle.
- City of Troy (1998): analysis of business processes in Bureau of Code Enforcement, Personnel Office, Finance Office, and Mayor's Office. Recommendations were fully funded by the New York State Archives in the 1999-2000 grant cycle.
- City of New York (1999): analysis of records management methods for Division of Records and Information Services.
- Ulster County Board of Cooperative Educational Services (1999): inventory of electronic records maintained by four school districts served by Ulster BOCES. Follow-up grant funded in 2000-2001 grant cycle.
- Enlarged City School District of Troy (1999): survey of electronic records maintained by selected business offices.
- Berkshire Union Free School District (1999): analysis of vital records protection for electronic records.

- Town of Somers (1999): analysis of business processes in five departments: Assessor, Town Planner, Town Engineer, Building Inspector, and Receiver of Taxes. Recommendations were fully funded by the New York State Archives in 2000-2001 grant cycle.
- Town of Rye (2000): analysis of business processes in three town departments: Assessor, Receiver of Taxes, and Building Inspector. Recommendations were funded by the New York State Archives in 2001-2002 grant cycle.
- Town of North East (2000): analysis of business processes in four town departments: Assessor, Planning, Zoning, and Building Inspector. Recommendations were funded by the New York State Archives in 2001-2002 grant cycle.
- Ulster County Board of Cooperative Educational Services (2000): development of retention schedules for electronic records maintained by three school districts served by Ulster BOCES.
- Town of New Windsor (2001): analysis of fingerprinting requirements for criminal records maintained by Police Department. Completed in March 2001.
- Village of Lynbrook (2001): analysis of business processes in five village departments: Assessor, Village Clerk, Village Court, Building Inspector, and Police Department. Completed in May 2001. Recommendations funded by the New York State Archives in the 2002-2003 grant cycle.
- New York City Board of Education (2001): analysis of business processes for teacher records, including feasibility study for imaging requirements. Completed June 2001.
- Lewis County Clerk (2001-2002): business process analysis for land and court records. Completed January 2002. Recommendations fully funded by the New York State Archives in the 2002-2003 grant cycle.
- New York City, Dept. of Housing Preservation and Development (2001-2002): needs assessment for document imaging implementation. Completed January 2002.
- Town/Village of Harrison (2001-2002): business process analysis in three departments: Assessor, Building Department, and Engineering Department. Completed January 2002. Recommendations fully funded by the New York State Archives in the 2002-2003 grant cycle.
- Massapequa Union Free School District (2002): analysis of inactive student, special education, and business records. Completed June 2002.
- Copiague Union Free School District (2002-2003): inventory and planning project involving student and business department records. Completed June 2003.

- North Babylon Union Free School District (2002-2003): inventory and planning project involving inactive records in offsite storage. Completed June 2003.
- Brooklyn Borough President (2003-2004): analysis of business processes for control of constituent correspondence. Completed February 2004. Recommendations funded by the New York State Archives in 2005-6 grant cycle.
- New York City Department of Probation (2003-2004): needs assessment for management of probation case files in borough branches. Completed February 2004. Recommendations funded by the New York State Archives in 2004-5 grant cycle.
- New York City Department of Parks and Recreation (2003-2004): needs assessment for management of records in selected divisions. . Completed June 2004. Recommendations funded by the New York State Archives in 2004-5 grant cycle.
- Roosevelt Island Operating Corporation (2004-2005): needs assessment for management of records of public benefit company. Completed in December 2004. Recommendations funded by the New York State Archives in 2005-6 and 2010-11 grant cycles.
- Rockland County BOCES (2004-5): needs assessment for imaging services to be offered to component school districts. Completed in December 2004. Recommendations funded by the New York State Archives in 2005-6 grant cycle.
- New York County District Attorney (2004-5): needs assessment for electronic document imaging. Completed June 2005. Recommendations funded by the New York State Archives in 2006-7 grant cycle.
- New York City Department of Finance (2004-5): revision of retention schedules for records maintained by six divisions. Completed June 2005.
- New York City Department of Information and Telecommunications Technology (2004-5): evaluation of historical records maintained by Citywide GIS Unit, NYC.gov, and 311 non-emergency service. Completed June 2005.
- Columbia County Clerk (2004-5): survey of vital electronic records with recommendations for disaster recovery. Completed June 2005. Recommendations funded by the New York State Archives in 2006-7 grant cycle.
- New York City Department of Finance (2005-6): survey of vital electronic records with recommendations for disaster recovery. Completed June 2006.

- New York City Department of Youth and Community Development (2006-7): needs assessment for records associated with Out of School Time (OST) program. Completed June 2007. Recommendations funded by the New York State Archives in 2008-9 grant cycle.
- New York City Health and Hospitals Corporation (2006-7): needs assessment for further development of the agency's document management system. Completed February 2007.
- City University of New York (2006-7): needs assessment for records management on CUNY campuses and in central office. Completed June 2007. Recommendations funded by the New York State Archives in 2007-8 grant cycle.
- Town of Oyster Bay (2006-7): needs assessment / survey of record retention practices in Town departments. Completed June 2007.
- Brooklyn Borough President (2007-8): needs assessment for historical records maintained by topographical unit. Completed January 2008. Recommendations funded by the New York State Archives in 2008-9 grant cycle.
- Albany City School District (2007-8): inventory and needs assessment for electronic records. Completed in June 2008. Recommendations funded by the New York State Archives in 2008-9 grant cycle.
- City University of New York (2007-8): pilot implementation and testing of new CUNY retention schedule at Bronx Community College and John Jay College. Completed June 2008.
- New York City Department of Finance (2007-8): needs assessment for acquisition and implementation of software to manage inactive records in warehouse location. Completed June 2008. Recommendations funded by New York State Archives in 2010-11 grant cycle.
- Town of Ramapo (2008-9): needs assessment for management of email. Completed January 2009.
- Town of Southold (2008-9): needs assessment for property information system. This project is ongoing now. Completed January 2009. Recommendations funded by New York State Archives in the 2009-10 grant cycle.
- City University of New York (2008-9): survey of electronic records relevant for e-discovery in employment-related litigation. Completed June 2009.
- Albany City School District (2008-9): preparation of procedures for management of email for storage in electronic records repository. Completed March 2009.

- Town of East Hampton (2008-9): needs assessment for engineering records. Completed June 2009. Recommendations funded by New York State Archives in 2010-11 grant cycle.
- Town of North Hempstead (2008-9): needs assessment for case management software for use by Town Attorney. Completed January 2009.
- Westchester County Archives (2009-2010): needs assessment for records related to County-owned real estate. Completed June 2010.

Staff Attorney – Legal Research: Rick Surber, Esq.

Rick Surber is a Staff Attorney for Zasio Enterprises and specializes in domestic legal retention research and retention schedules. He received his undergraduate degree from Boise State University, and earned his Juris Doctor's degree from University of Idaho College of Law. During law school Rick gained experience by working as a contract researcher, performing a wide range of work in fields such as land use, environmental law, medical malpractice, and products liability. Following law school he passed the Idaho State Bar allowing him to practice law in Idaho State Courts, as well as the US Courts, District of Idaho.

Part 4 – Client References

Bank of America

From 2008 to the present, the Zasio Consultants have been engaged in conducting a global records retention initiative for this large financial institution. In Phase 1, we refreshed the current US-based retention schedule. In the second phase, we developed a single set of retention rules of global applicability, based on the US baseline but accommodating country-specific requirements where necessary. In the third phase, these activities were extended to Merrill Lynch. The total number of countries is forty-three.

Client contact: Susan K. Goodman, CRM, ECM/P
Senior Vice President, Digital Records Program
50 Rockefeller Plaza
New York, NY 10020
Phone: 917.225.9483
E-mail: susan.k.goodman@bankofamerica.com

Highmark Inc.

For this large health insurance company (Pennsylvania Blue Cross & Blue Shield), the Zasio Consultants recently completed a multi-task engagement. This assignment occurred during 2008-2009. We developed the following deliverables: An enterprise-wide records management plan, a records inventory / survey, a new records retention schedule, new / revised records-related policies, procedures for records disposition / disposal, recommendations pertaining to e-discovery compliance, recommendations for data mapping, records management training content, records management software recommendations, and future technology recommendations.

Client Contact: Mr. Andrew Kopac
Corporate Records Manager
1800 Camp Hill Center
Camp Hill, PA 17011
Highmark Inc.
Phone: 717.302.3759
E-mail: Andrew.kopac@highmarkmedicareservices.com

RTI International, Research Triangle Park, North Carolina

Zasio Enterprises completed development of a new global records retention schedule for this multinational contract research company. The scope of the engagement included 9 countries outside the United States. We performed legal research to ascertain the retention requirements with which RTI is obliged to comply, and developed a new functional, global retention schedule.

Client Contact: Mr. David L. Brodish, M.A., R.A.C.
Director, Regulatory and Quality Assurance
RTI International

3040 Cornwallis Road
Research Triangle Park, NC 27709
Phone: 919.541.7131
E-mail: dbrodish@rti.org

Tonawanda, Town of (New York)

The Zasio Consultants conducted a comprehensive analysis of the current situation concerning recordkeeping and records management for this New York municipality and developed recommendations for improvement. These were designed to bring the town into compliance with records management requirements of the New York State Archives, as well as to introduce best professional practices over, systematically and based on approved program priorities, over a multi-year period.

Client Contact: Ms. Melissa Brinson
Town Clerk
Town of Tonawanda
2919 Delaware Avenue
Kenmore, NY 14217
Phone: 716.877.8800
Email: mbrinson@tonawanda.ny.us

Proposed Project Pricing

Zasio Enterprises, Inc. estimates the cost of the work described herein as itemized below. Please note that these costs are *inclusive of fees and expenses*.

Records Management Consulting Services – Fees and Expenses

Task 1 – Conduct Survey of Town Electronic Recordkeeping Systems	\$7,500.00
Task 2 – Analyze Data and Prepare Recommendations.....	\$10,000.00
Task 3 – Prepare Interim Draft / Final Reports.....	\$8,500.00
Task 4 – Present Findings and Recommendations to Town.....	\$3,000.00
Task 5 – Assist Town with Grant Application	\$-0-
Grand Total Fixed Price	\$29,000.00

Invoicing / Payment Terms

Invoices will be rendered at month-end; payment terms are net 45 days.

Period of Project Performance

The Zasio Consultants project a project timeline of three months (or less, if possible) to accomplish the work described herein.

- Task 1 – Conduct Survey of Town Recordkeeping Systems – Month one
- Task 2 – Analyze Data and Prepare Recommendations – Month two
- Task 3 – Prepare Draft / Final Reports – Month three
- Task 4 – Present Findings and Recommendations to Town – As soon as can be scheduled following acceptance of final report

Resources Provided by Cheektowaga

Zasio Enterprises, Inc. performs consulting assignments such as is proposed here with a minimum of involvement / disruption on the part of its clients. For the work described herein, we require only a client project coordinator, who can assist in scheduling interviews and other on-site tasks. Cheektowaga will, however, need to allocate sufficient analytical talent from various sectors of the business to perform a content review of the deliverables, and provide comments to us.

Attachment: Zasio Proposal Rev 15 Feb 2011 (2) (RES-2011-171 : Records Management Consultant)



Town of Cheektowaga

Work Session

~ Minutes ~

3301 Broadway
Cheektowaga, NY 14227

<http://www.town.cheektowaga.ny.us>

Alice Magierski
716-686-3400

Tuesday, March, 29, 2011

6:00 PM

Council Office

I. Call to Order

6:00 PM Meeting called to order on March 29, 2011 at Council Office, Conference Room, Cheektowaga, NY.

Attendee Name	Organization	Title	Status	Arrived
Mary Holtz	Town of Cheektowaga	Supervisor	Present	
Patricia Jaworowicz	Town of Cheektowaga	Councilmember	Absent	
Jeff Swiatek	Town of Cheektowaga	Councilmember	Absent	
James Rogowski	Town of Cheektowaga	Councilmember	Present	
Richard Zydel	Town of Cheektowaga	Councilmember	Present	
Charles Markel	Town of Cheektowaga	Councilmember	Present	
Stanley Kaznowski	Town of Cheektowaga	Councilmember	Present	

2. Additional Attendees

Brian Krause, Director of Finance and Administration
Anthony Romano, Coordinator of Employee Relations
Kevin Schenk, Town Attorney

II. Resolutions



1. RESOLUTION 2011-181

Renewal of Crime and Faithful Performance Insurance

Sponsored By: Supervisor Holtz, Councilmember Kaznowski

WHEREAS, the Town's Crime (including Employee Theft Coverage and Faithful Performance Insurance Coverage) expire on March 30, 2011, and

WHEREAS, Holfoth Risk Management, the Town's insurance consultant, solicited proposals for the renewal of these insurance coverages, and

WHEREAS, Fidelity and Deposit Companies is offering the Town the option of replacing the Employee Theft coverage with the Faithful Performance coverage at a reasonable cost (\$343 additional), and

WHEREAS, after review of the proposals received, Holfoth Risk Management recommended that the Town of Cheektowaga accept the proposal from Fidelity and Deposit Companies (through First Niagara Risk Management) for Crime Insurance (including \$500,000 Faithful Performance coverage, with \$5,000 deductible) as follows:

<u>Premium for Main Policy</u>	<u>Premium for Police Policy</u>	<u>Total Premium</u>
\$239 + \$7,091	\$104 + \$2,767	\$10,201

NOW, THEREFORE, BE IT RESOLVED, that this Town Board hereby awards the above referenced Town's Crime (including Faithful Performance coverage) insurance to Fidelity and Deposit Companies (through First Niagara Risk Management) for \$10,201 for the period March 30, 2011 to March 30, 2012, and BE IT FURTHER

RESOLVED, that the Supervisor be and hereby is authorized and directed to execute any and all documents to effectuate this property insurance coverage.

RESULT:	ADOPTED [UNANIMOUS]
MOVER:	Mary Holtz, Supervisor
SECONDER:	Stanley Kaznowski, Councilmember
AYES:	Holtz, Rogowski, Zydel, Markel, Kaznowski
ABSENT:	Patricia Jaworowicz, Jeff Swiatek



2. RESOLUTION 2011-182

Renewal of Property Insurance

Sponsored By: Supervisor Holtz, Councilmember Markel

WHEREAS, the Town’s Property Insurance Coverage expires on March 30, 2011, and

WHEREAS, Holfoth Risk Management, the Town’s insurance consultant, solicited proposals for the renewal of the Town’s property insurance coverage, and

WHEREAS, after review of the proposals received, Holfoth Risk Management recommended that the Town of Cheektowaga accept the proposal from One Beacon Insurance Company for \$52,762 for the following listed options:

<u>Coverage</u>	<u>Limits</u>	<u>Deductible</u>
Buildings, Contents	\$55,769,364	\$25,000
Contractor’s Equipment	\$2,786,190	\$2,500
EDP, Media	\$1,610,000	\$2,500
Flood (non Flood Zones)	\$5,000,000	\$25,000
Earthquake	\$1,000,000	\$25,000
Boiler and Machinery	\$55,769,364	\$25,000

, and

WHEREAS, Holfoth Risk Management has also recommended that the Town of Cheektowaga accept the proposal from Firemen’s Fund for the following vehicle physical damage for \$10,710 :

<u>Limits</u>	<u>Deductible</u>
\$3,000,000	\$10,000

, and

WHEREAS, this Town Board wishes to award the above referenced Town’s property insurance to One Beacon Insurance Company and Firemen’s Fund, NOW, THEREFORE, BE IT

RESOLVED, that this Town Board hereby awards the Town’s Buildings and Contents property insurance as outlined above to One Beacon Insurance Company (through Lawley Service, Inc.) for the period from March 30, 2011 to March 30, 2012 for a premium of \$52,762, and BE IT FURTHER

RESOLVED, that this Town Board hereby awards the Town’s Vehicle Physical Damage insurance to Firemen’s Fund (through Lawley Service, Inc.) for the period from March 30, 2011 to March 30, 2012 for a premium of \$10,710, and BE IT FURTHER

RESOLVED, that the Supervisor be and hereby is authorized and directed to execute any and all documents to effectuate this property insurance coverage.

RESULT: ADOPTED [UNANIMOUS]

MOVER:	Mary Holtz, Supervisor
SECONDER:	Charles Markel, Councilmember
AYES:	Holtz, Rogowski, Zydel, Markel, Kaznowski
ABSENT:	Patricia Jaworowicz, Jeff Swiatek

III. Work Session Ends



Town of Cheektowaga

Regular Meeting

~ Minutes ~

3301 Broadway
Cheektowaga, NY 14227
<http://www.town.cheektowaga.ny.us>

Alice Magierski
716-686-3400

Monday, April, 4, 2011

6:45 PM

Council Chambers

I. Call to Order

6:45 PM Meeting called to order on April 4, 2011 at Council Chambers, 3301 Broadway St, Cheektowaga, NY.

Attendee Name	Organization	Title	Status	Arrived
Mary Holtz	Town of Cheektowaga	Supervisor	Present	
Patricia Jaworowicz	Town of Cheektowaga	Councilmember	Present	
Jeff Swiatek	Town of Cheektowaga	Councilmember	Present	
James Rogowski	Town of Cheektowaga	Councilmember	Present	
Richard Zydel	Town of Cheektowaga	Councilmember	Present	
Charles Markel	Town of Cheektowaga	Councilmember	Absent	
Stanley Kaznowski	Town of Cheektowaga	Councilmember	Present	

2. Additional Attendees

Thomas Adamczak, Supervising Building and Plumbing Inspector
Jerry Gabryszak, Director of Community Development
Brian Krause, Director of Finance and Administration
John Marriott, Planning Board Chairman
William Pugh, Town Engineer
Anthony Romano, Coordinator of Employee Relations
Kevin Schenk, Town Attorney
Kerry Switalski, Senior Services Director
Mark Wegner, Highway Superintendent
David Zack, Chief of Police

II. Public Hearings

1. A Local Law to Amend the Code of Ethics

This being the time and place advertised for a Public Hearing, the Supervisor directed the Town Clerk to present that such notice has been duly published and posted; upon the order of the Supervisor such proof was duly filed.

The Supervisor announced that the Town Board would hear all persons interested in the subject of the hearing. Comments were heard, after which the Supervisor declared the hearing closed, decision was reserved.

RESULT: CLOSED [UNANIMOUS]
MOVER: James Rogowski, Councilmember
SECONDER: Richard Zydel, Councilmember
AYES: Holtz, Jaworowicz, Swiatek, Rogowski, Zydel, Kaznowski

ABSENT: Charles Markel

III. Public Comment Period

IV. Resolutions



1. RESOLUTION 2011-183

Transfer of Funds

Sponsored By: Supervisor Holtz, Councilmember Swiatek

BE IT RESOLVED, that the following transfer is hereby approved and made a part hereof;

2010

HIGHWAY FUND

FROM:	300.5142.4029	Salt	\$	867.00
	300.9010.8101	Retirement		793.00
TO:	300.5142.4180	Contracted Snow Removal	\$	1,660.00

RISK RETENTION FUND

FROM:	101.1910.2798	Appropriated Fund Balance	\$	804,198.00
	101.1931.4703	Judgements & Claims		8,171.00
TO:	101.1932.4703	Judgements & Claims	\$	803,689.00
	101.1930.4703	Judgements & Claims		8,680.00

RESULT:	ADOPTED [UNANIMOUS]
MOVER:	Mary Holtz, Supervisor
SECONDER:	Jeff Swiatek, Councilmember
AYES:	Holtz, Jaworowicz, Swiatek, Rogowski, Zydel, Kaznowski
ABSENT:	Charles Markel



2. RESOLUTION 2011-184

Warrant

Sponsored By: Supervisor Holtz, Councilmember Swiatek

BE IT RESOLVED, that the following Vouchers & Warrants submitted to the Town of Cheektowaga prior to April 1, 2011 are hereby approved and made a part hereof;

GENERAL FUND	\$	862,409.41
RISK RETENTION FUND		20,679.45
HUD HOUSING REHABILITATION		31,211.00
SPECIAL DISTRICT FUND		211,865.09
HIGHWAY FUND		197,246.03
CAPITAL FUND		204,374.43
TRUST & AGENCY FUND		18,216.79
HUD CDBG FUND		1,508.50
PART TOWN FUND		32,046.19
NYS AFFORDABLE HOUSING		5,691.00
		<u>5,691.00</u>
	\$	1,585,247.89

RESULT:	ADOPTED [UNANIMOUS]
MOVER:	Mary Holtz, Supervisor
SECONDER:	Jeff Swiatek, Councilmember
AYES:	Holtz, Jaworowicz, Swiatek, Rogowski, Zydel, Kaznowski
ABSENT:	Charles Markel



3. RESOLUTION 2011-185

Adopt Local Law No. 1 of 2011 - a Local Law to Amend the Code of Ethics

Sponsored By: Councilmember Swiatek, Supervisor Holtz

WHEREAS, pursuant to Sections 811 and 812 of the General Municipal Law of the State of New York, the Town of Cheektowaga previously adopted a Code of Ethics (now Chapter 18 of the Code of the Town of Cheektowaga), and

WHEREAS, Section 18-4 of said Code of Ethics requires certain Town employees and elected officials to file financial disclosure statements each year with the Board of Ethics, and

WHEREAS, some of the titles listed in Section 18-14 which are required to file a financial disclosure statement have changed over the years, and there is a need to update the Code of Ethics to reflect these changes, as well as to reflect other changes in job duties for those required to file financial disclosure statement, and

WHEREAS, the Town Attorney has prepared a draft of a "Local Law to Amend the Code of Ethics", and

WHEREAS, in accordance with the provisions of the Town Law/Municipal Home Rule Law of the State of New York, a public hearing was held on the 4th day of April, 2011 at 6:45 P.M. at a meeting of the Town Board at the Cheektowaga Town Hall, 3301 Broadway, Cheektowaga, New York; at which hearing all interested parties were given an opportunity to be heard as to whether Local Law Intro No. 2011-1 of the Year 2011, entitled "A Local Law to Amend the Ethics Law" should be enacted, and

WHEREAS, it is in the public interest to adopt said local law, NOW, THEREFORE, BE IT

RESOLVED, that Local Law No. 1 of the Year 2011, entitled "A Local Law to Amend the Ethics Law", which is attached hereto and made a part hereof, be and the same is hereby enacted, and BE IT FURTHER

RESOLVED, that Local Law No. 1 of the Year 2011 shall be effective upon filing wit the Secretary of State, and BE IT FURTHER

RESOLVED, that the Town Clerk shall file one (1) certified copy of this local law in her office and one (1) certified copy with the Secretary of State.

LOCAL LAW NO. 1 OF THE YEAR 2011
A LOCAL LAW TO AMEND THE
CODE OF ETHICS OF THE TOWN OF CHEEKTOWAGA

Section 18-14 of the Ethics Law of the Town of Cheektowaga shall be amended to read as follows:

§18-14. Disclosure of financial status

The Town of Cheektowaga recognizes that matters of finance do exist which are so personal in nature and are so unrelated to the performance of public employees' duties that no useful purpose can be served by such disclosure. Nonetheless, certain financial information may be relevant to a public official or employee's duties and may impact the integrity of the town government. To that extent:

A.

Those town officers, employees who are so designated from time to time by Town Board resolution, shall file with the Board of Ethics of the Town of Cheektowaga annually, on or before May 15 of every year following the enactment of this article, during the term of their office, a statement of their financial holdings, assets, liabilities and net worth. The time for filing such statement may be extended pursuant to the rules of the Board of Ethics for justifiable cause and for undue hardship upon application to the Board of Ethics pursuant to the rules and regulations set forth in this article and, if applicable, to §§811, 812 and 813 of the General Municipal Law of the State of New York.

B.

In addition to those officers and employees referenced herein in Section 18-14.A., any local officer or employee who is determined by the Town Board to be a policymaker or perform any of the duties listed in sections 18-15A(9)(a) through (d) shall be required to file a financial disclosure statement.

C.

The designated officers and employees and elected officials shall file with the Board of Ethics a disclosure statement answering each and every question. The statement shall be in the form established by the Board of Ethics.

RESULT:	ADOPTED [UNANIMOUS]
MOVER:	Jeff Swiatek, Councilmember
SECONDER:	Mary Holtz, Supervisor
AYES:	Holtz, Jaworowicz, Swiatek, Rogowski, Zydel, Kaznowski
ABSENT:	Charles Markel



4. RESOLUTION 2011-186

Adoption of Amendments to Vehicle and Traffic Law - Como Park Blvd.

Sponsored By: Councilmember Zydel, Councilmember Rogowski

WHEREAS, this Town Board held a public hearing on March 21, 2011 to consider the advisability of adopting proposed amendments to Chapter 235 of the Code of the Town of Cheektowaga (Vehicle and Traffic), said hearing being held in accordance with Notice thereof which was duly published as required by law, at which hearing an opportunity to be heard was afforded all persons interested in the subject thereof,

NOW, THEREFORE, BE IT RESOLVED, as follows:

Section 1.

That this Town Board determines it is in the public interest to adopt the following amendments to Chapter 235 of the Code of the Town of Cheektowaga, County of Erie and State of New York, and said amendments are herewith adopted and enacted:

ARTICLE V. Schedules, Section 235-49, Schedule X: Parking Prohibited in Designated Locations, shall be amended by deleting therefrom the following:

In accordance with the provisions of §235-34, no person shall park a vehicle at any time upon any of the following described streets or parts of streets:

COMO PARK BOULEVARD - North and south sides: from the east curb line of Union Road to the west curb line of Countryside Lane.

ARTICLE V. Schedules, Section 235-49, Schedule X: Parking Prohibited in Designated Locations, shall be amended by adding thereto the following:

In accordance with the provisions of §235-34, no person shall park a vehicle at any time upon any of the following described streets or parts of streets:

COMO PARK BOULEVARD - north side: from the east curb line of Union Road to a point opposite the west curb line of Countryside Lane.

COMO PARK BOULEVARD - south side: from the east curb line of Union Road to the entrance to John C. Stiglmeier Park.

COMO PARK BOULEVARD - south side: from the west curb line of Countryside Lane to a point 500 feet west of the west curb line of Countryside Lane.

Section 2. Time to Take Effect

These amendments shall take effect when properly posted within a reasonable time except those parts, if any, which are subject to approval under Section 1684 of the Vehicle and Traffic

Law of the State of New York.

Any part or parts of these amendments which are subject to approval under Section 1684 of the Vehicle and Traffic Law of the State of New York shall take effect from and after the day on which approval in writing is received from the New York State Traffic Commission.

Section 3. Territorial Application

These amendments shall apply to all of the Town of Cheektowaga, Erie County, New York outside of the villages of Depew and Sloan.

Section 4. Publication

That these amendments to Chapter 235 (formerly Chapter 76) of the Code of the Town of Cheektowaga shall be entered into the minutes of the Town Board and shall be published in the CHEEKTOWAGA BEE, a newspaper published in this Town, and affidavits of such publication shall be filed with the Town Clerk and the Town Clerk shall likewise enter in the Ordinance Book a copy of said amendments specifying the date of adoption thereof.

RESULT:	ADOPTED [UNANIMOUS]
MOVER:	Richard Zydel, Councilmember
SECONDER:	James Rogowski, Councilmember
AYES:	Holtz, Jaworowicz, Swiatek, Rogowski, Zydel, Kaznowski
ABSENT:	Charles Markel



5. RESOLUTION 2011-187

Change Order No. 1 (General Construction) Police & Court Building Renovations and Addition

Sponsored By: Supervisor Holtz, Councilmember Rogowski

WHEREAS, the contract for General Construction Work for the Police & Court Building Renovations and Addition was awarded by Town Board Resolution dated September 7, 2010 to Burgio & Campofelice, Inc., 2570 Walden Avenue, Cheektowaga, New York 14225 in the amount of \$9,033,643.00, AND

WHEREAS, the project architect, Trautman Associates, and the Town Engineer have recommended the approval of Change Order No. 1 (General Construction Work) which provides for an addition and a credit to the original contract amount as further outlined in the change order documents, NOW, THEREFORE, BE IT

RESOLVED, that Change Order No. 1 (General Construction Work) for the Police and Court Building Renovations and Addition in the amount of \$7,415.00 as an addition to the contract of Burgio & Campofelice, Inc. be and hereby is approved, AND, BE IT FURTHER

RESOLVED, that the Supervisor is hereby authorized and directed to execute said change order documents on behalf of this Town Board, chargeable to Account #500-1440-2528-5025.

RESULT:	ADOPTED [UNANIMOUS]
MOVER:	Mary Holtz, Supervisor
SECONDER:	James Rogowski, Councilmember
AYES:	Holtz, Jaworowicz, Swiatek, Rogowski, Zydel, Kaznowski
ABSENT:	Charles Markel



6. RESOLUTION 2011-188

Notice to Bidders - Purchase of Firearms for Police Department

Sponsored By: Councilmember Jaworowicz, Councilmember Rogowski

BE IT RESOLVED, that the Town Clerk is hereby directed to publish a Notice to Bidders for the purchase of One hundred thirty two (132) Model 22 Generation 4 Glock Pistols with fixed sights and three (3) Magazines, and Fourteen (14) Model 23 Generation 4 Glock Pistols with fixed sights and three (3) Magazines, with trade-in of 145 Glock Model 22 1st Generation pistols, said notice to be published in the Cheektowaga Bee, be it further

RESOLVED, that sealed bids will be received by the Town Clerk on the 13th day of April, 2011, at 11:00 A.M., at a public bid opening to be held in the Council Chambers in the Cheektowaga Town Hall, 3301 Broadway, Cheektowaga, New York, 14227.

NOTICE TO BIDDERS

Sealed proposals will be received and opened by the Town Clerk of the Town of Cheektowaga on April 13, 2011 at 11:00 A.M. in the Council Chambers, First Floor, Cheektowaga Town Hall, 3301 Broadway, Cheektowaga, New York, for the purchase of One hundred thirty two (132) Model 22 Generation 4 Glock Pistols with fixed sights and three (3) Magazines, and Fourteen (14) Model 23 Generation 4 Glock Pistols with fixed sights and three (3) Magazines, with trade-in of 145 Glock Model 22 1st Generation pistols.

Information for bidders and specifications may be obtained from the Town Clerk at her office in said Town. The Town Board reserves the right to consider informal any bid not prepared and submitted in accordance with the provisions of the specifications and contract documents, and may waive any informality, make an award to other than the low bidder, should it be in the best interest of the Town or reject any or all bids.

By Order of the Town Board of the Town of Cheektowaga, Erie County, New York.

Table with 2 columns: Label (RESULT, MOVER, SECONDER, AYES, ABSENT) and Content (ADOPTED [UNANIMOUS], Patricia Jaworowicz, Councilmember, James Rogowski, Councilmember, Holtz, Jaworowicz, Swiatek, Rogowski, Zydel, Kaznowski, Charles Markel)



7. RESOLUTION 2011-189

Notice to Bidders - Demolition of 2371 Genesee Street

Sponsored By: Councilmember Kaznowski, Supervisor Holtz

WHEREAS, it is in order that bids be advertised for the demolition of structures located at 2371 Genesee Street in the Town of Cheektowaga, and

WHEREAS, specifications for same have been prepared by Nussbaumer & Clarke, Inc., NOW, THEREFORE, BE IT

RESOLVED, that the Town Clerk be and hereby is directed to publish a Notice to Bidders in connection with the demolition of 2371 Genesee Street, said notice to be published in the CHEEKTOWAGA BEE, and BE IT FURTHER

RESOLVED, that sealed bids will be received and opened by the Town Clerk at a public bid opening to be held in the Council Chambers at the Cheektowaga Town Hall on Wednesday, April 13, 2011 at 11:00 A.M.

NOTICE TO BIDDERS

Sealed proposals will be received by the Town of Cheektowaga on Wednesday, April 13, 2011 at 11:00 A.M. at the Town Hall, 3301 Broadway, Cheektowaga, New York, for the demolition of 2371 Genesee Street in the Town of Cheektowaga.

Information for bidders and specifications may be obtained from the Town Clerk at her office in said Town.

The Town Board reserves the right to consider informal any bid not prepared and submitted in accordance with the provisions of the specification and contract documents, and may waive any informalities, make an award to other than the low bidder, or reject any or all bids should it be in the best interest of the Town.

BY ORDER OF THE TOWN BOARD OF THE TOWN OF CHEEKTOWAGA, ERIE COUNTY, NEW YORK.

Alice Magierski
Town Clerk

Dated: April 4, 2011

RESULT:	ADOPTED [UNANIMOUS]
MOVER:	Stanley Kaznowski, Councilmember
SECONDER:	Mary Holtz, Supervisor
AYES:	Holtz, Jaworowicz, Swiatek, Rogowski, Zydel, Kaznowski
ABSENT:	Charles Markel



8. RESOLUTION 2011-190

Notice to Bidders - Demolition of 1112 Walden Avenue

Sponsored By: Councilmember Kaznowski, Supervisor Holtz

WHEREAS, it is in order that bids be advertised for the demolition of a structure located at 1112 Walden Avenue in the Town of Cheektowaga, and

WHEREAS, specifications for same have been prepared by Nussbaumer & Clarke, Inc., NOW, THEREFORE, BE IT

RESOLVED, that the Town Clerk be and hereby is directed to publish a Notice to Bidders in connection with the demolition of 1112 Walden Avenue, said notice to be published in the CHEEKTOWAGA BEE, and BE IT FURTHER

RESOLVED, that sealed bids will be received and opened by the Town Clerk at a public bid opening to be held in the Council Chambers at the Cheektowaga Town Hall on Wednesday, April 13, 2011 at 11:00 A.M.

NOTICE TO BIDDERS

Sealed proposals will be received by the Town of Cheektowaga on Wednesday, April 13, 2011 at 11:00 A.M. at the Town Hall, 3301 Broadway, Cheektowaga, New York, for the demolition of 1112 Walden Avenue in the Town of Cheektowaga.

Information for bidders and specifications may be obtained from the Town Clerk at her office in said Town.

The Town Board reserves the right to consider informal any bid not prepared and submitted in accordance with the provisions of the specification and contract documents, and may waive any informalities, make an award to other than the low bidder, or reject any or all bids should it be in the best interest of the Town.

BY ORDER OF THE TOWN BOARD OF THE TOWN OF CHEEKTOWAGA, ERIE COUNTY, NEW YORK.

Alice Magierski
Town Clerk

Dated: April 4, 2011

Table with 2 columns: Field (RESULT, MOVER, SECONDER, AYES, ABSENT) and Value (ADOPTED [UNANIMOUS], Stanley Kaznowski, Councilmember, Mary Holtz, Supervisor, Holtz, Jaworowicz, Swiatek, Rogowski, Zydel, Kaznowski, Charles Markel)



9. RESOLUTION 2011-191

Notice to Bidders - Fencing at the Town Hall Campus

Sponsored By: Councilmember Rogowski, Supervisor Holtz

WHEREAS, it is in order that bids be advertised for the furnishing and installation of fencing at the Town Hall Campus, NOW, THEREFORE, BE IT

RESOLVED, that the Town Clerk be directed to publish a Notice to Bidders for the furnishing and installation of fencing at the Town Hall Campus, said notice to be published in the CHEEKTOWAGA BEE, AND, BE IT FURTHER

RESOLVED, that sealed bids will be received by the Town of Cheektowaga on April 20, 2011 at 11:00 a.m., at the Town Hall, at which time they will be publicly opened and read.

NOTICE TO BIDDERS

Sealed proposals will be received by the Town of Cheektowaga on April 20, 2011 at 11:00 a.m. at the Cheektowaga Town Hall, 3301 Broadway, Cheektowaga, New York 14227 for the furnishing and installation of wood and chain link fencing and gates at the Town Hall Complex for the calendar year of 2011.

Information for bidders and specifications may be obtained from the Office of the Town Clerk, 3301 Broadway, Cheektowaga, New York 14227.

The Town Board reserves the right to consider informal any bid not prepared and submitted in accordance with the provisions of the specifications and contract documents, and may waive any informalities, make an award to other than the low bidder, should it be in the best interest of the Town, or reject any and all bids.

Each proposal must be accompanied by a certified check for a sum equal to five percent (5%) of the amount of the bid, payable to the Town of Cheektowaga, New York, or bond with sufficient sureties to be approved by the attorney for the Town of Cheektowaga, New York.

By order of the Town Board of the Town of Cheektowaga, Erie County, New York.

Alice Magierski
Town Clerk

DATED: April 4, 2011

RESULT:	ADOPTED [UNANIMOUS]
MOVER:	James Rogowski, Councilmember
SECONDER:	Mary Holtz, Supervisor
AYES:	Holtz, Jaworowicz, Swiatek, Rogowski, Zydel, Kaznowski
ABSENT:	Charles Markel



10. RESOLUTION 2011-192

Notice to Bidders - One (1) 2011 or Newer High Velocity Sewer Cleaner with 2012 Cab Chassis

Sponsored By: Councilmember Kaznowski, Councilmember Zydel

WHEREAS, it is in order that bids be advertised for the furnishing of one (1) 2011 or newer High Velocity Sewer Cleaner with 2012 Cab Chassis for the Sewer Maintenance Department, NOW, THEREFORE, BE IT

RESOLVED, that the Town Clerk be directed to publish a Notice to Bidders for the furnishing of one (1) 2011 or newer High Velocity Sewer Cleaner with 2012 Cab Chassis, said notice to be published in the CHEEKTOWAGA BEE, AND, BE IT FURTHER

RESOLVED, that sealed bids will be received by the Town of Cheektowaga on April 20, 2011 at 11:00 a.m., at the Town Hall, at which time they will be publicly opened and read.

NOTICE TO BIDDERS

Sealed proposals will be received and considered by the Town Board of the Town of Cheektowaga on April 20, 2011 at 11:00 a.m., corner of Broadway and Union Roads, for the purchase of one (1) 2011 or newer High Velocity Sewer Cleaner with 2012 Cab and Chassis.

Information for bidders and specifications may be obtained from the Town Clerk at her office in said Town.

The Town Board reserves the right to consider informal any bid not prepared and submitted in accordance with the provisions of the specifications and contract documents, and may waive any informalities, make an award to other than the low bidder, should it be in the best interest of the Town, or reject any or all bids.

Each proposal must be accompanied by a certified check for a sum equal to five percent (5%) of the amount of the bid, payable to the Town of Cheektowaga, New York, or bond with sufficient sureties to be approved by the attorney for the Town of Cheektowaga, New York.

By order of the Town Board of the Town of Cheektowaga, Erie County, New York.

Alice Magierski
Town Clerk

DATED: April 4, 2011

RESULT:	ADOPTED [UNANIMOUS]
MOVER:	Stanley Kaznowski, Councilmember
SECONDER:	Richard Zydel, Councilmember
AYES:	Holtz, Jaworowicz, Swiatek, Rogowski, Zydel, Kaznowski
ABSENT:	Charles Markel



11. RESOLUTION 2011-193

Purchase Play Equipment for Stiglmeier Park

Sponsored By: Councilmember Rogowski, Councilmember Zydel

WHEREAS, The Facilities Department, Parks Division has requested authorization to purchase Playground Equipment for Stiglmeier Park, as specified in New York State OGS Contracts PC62097, AND

WHEREAS, funds for said purchase have been budgeted and are available under account number 500-7110-2517-5022 (DASNY GRANT), NOW, THEREFORE BE IT,

RESOLVED, that the Town Board hereby authorizes the purchase of Park Equipment, as detailed on the attached quotation for Stiglmeier Park in the amount of \$77,111.50 from:

PARKITECTS, Inc.
138 Ludlowville Road #1,
Lansing, NY 14882

Attachments:

[Parkitects](#)

RESULT: ADOPTED [UNANIMOUS]
MOVER: James Rogowski, Councilmember
SECONDER: Richard Zydel, Councilmember
AYES: Holtz, Jaworowicz, Swiatek, Rogowski, Zydel, Kaznowski
ABSENT: Charles Markel



12. RESOLUTION 2011-194

Approve Purchase of Police Car Computers

Sponsored By: Councilmember Jaworowicz, Councilmember Rogowski

WHEREAS, the Cheektowaga Police Department, in keeping in line with their plan of rotating out older car computers and replacing them with new models, is in need of purchasing 7 Panasonic Toughbook Model CF-31 car computers, AND

WHEREAS, the purchase of new car computers will allow the Police Department to keep up with new technology, keep the cost of repairs and maintenance down, and maintain their warranties, AND

WHEREAS, Synergy Global Solutions, has provided a quotation for 7 Panasonic Toughbook CF-31 computers, based on New York State OGS pricing, Contract # PC63049, and a three year warranty for each computer, AND

WHEREAS, funding has been allocated from budget line #100-3120-2204 for said purchase,

NOW, THEREFORE, BE IT RESOLVED, that the Town Board hereby authorizes the purchase of the Panasonic Toughbook CF-31 car computers in the amount of \$24,897.00 from:

Synergy Global Solutions
1100 Pittsford-Victor Road
Pittsford, NY 14534

RESULT:	ADOPTED [UNANIMOUS]
MOVER:	Patricia Jaworowicz, Councilmember
SECONDER:	James Rogowski, Councilmember
AYES:	Holtz, Jaworowicz, Swiatek, Rogowski, Zydel, Kaznowski
ABSENT:	Charles Markel



13. RESOLUTION 2011-195

Designation of Individuals Required to File Financial Disclosure Statement

Sponsored By: Councilmember Swiatek, Supervisor Holtz

WHEREAS, Section 18-14 of Chapter 18 of the Code of the Town of Cheektowaga (Code of Ethics) states that the Town Board can designate certain Town employees and elected officials to file financial disclosure statements each year with the Board of Ethics, and

WHEREAS, this Board has reviewed the job duties and responsibilities of Town employees to ascertain who should file the financial disclosure statement, NOW, THEREFORE, BE IT

RESOLVED that those employees with the following job titles be and hereby are required to file the annual statement of financial disclosure, effective immediately:

Accountant
Assessor
Assistant Code Enforcement Officers [formerly Assistant Building Inspector and Plumbing Inspector]
Assistant Superintendent, Wastewater Pump Station
Assistant Town Engineer
Automotive Mechanic Crew Chief
Bingo Inspectors
Candidates for Town Elected Office
Captain, Police Department
Chairperson, Board of Assessment Review
Chairperson, Board of Ethics
Chairperson, Cheektowaga Conservation Advisory Council
Chairperson, Emergency Medical Services Review
Chairperson, Environmental Advisory Committee
Chairperson, Planning Board
Chairperson, Traffic Safety Commission
Chairperson, Zoning Board
Chief of Police
Code Enforcement Officer [formerly Building Inspector]
Coordinator of Employee Relations
Council Members [formerly Councilmen]
Crew Chief [formerly Crew Chief, Central Garage and Working Crew Chief, Facilities Dept]
Deputy Receiver of Taxes & Assessments
Deputy Superintendent of Highways
Deputy Town Attorney & Prosecuting Attorney
Deputy Town Clerk
Director of Administration and Finance [formerly Chief Accountant]
Director of Community Development
Director of Senior Services
Executive Director, Youth and Recreation Services [formerly Director, Youth & Recreational Services Dept]
Fire Inspectors

General Crew Chief [formerly General Crew Chief, Sanitation Dept. & Sewer Maintenance Dept]
Housing Inspectors
Lieutenant in Charge of Vice, Gambling & Narcotics, Police Department
Members of Board of Assessment Review
Members of Board of Ethics
Members of Cheektowaga Economic Development Corp.
Members of the Planning Board
Members of Zoning Board
Program Coordinator (Youth)
Program Leader (Youth)
Real Property Appraiser
Recreation Leader
Recreation Supervisor [formerly Senior Recreation Supervisor]
Superintendent of Highways
Superintendent, Wastewater Pump Station
Supervising Code Enforcement Officer
Supervisor
Town Attorney
Town Clerk
Town Engineer
Zoning Inspector

RESULT:	ADOPTED [UNANIMOUS]
MOVER:	Jeff Swiatek, Councilmember
SECONDER:	Mary Holtz, Supervisor
AYES:	Holtz, Jaworowicz, Swiatek, Rogowski, Zydel, Kaznowski
ABSENT:	Charles Markel



14. RESOLUTION 2011-196

Authorize Supervisor to Sign Agreement with Nussbaumer & Clarke, Inc. for Professional Services

Sponsored By: Councilmember Kaznowski, Supervisor Holtz

WHEREAS, the existing Robicon Variable Frequency Drives (VFD's) and Reduced Voltage Starters (RVS) for the four (4) main pumps at the Main Pump Station, constructed in 1978, have reached the end of their expected service life and have become costly to service with limited parts availability, AND

WHEREAS, the Main Pump Station Superintendent and Town Engineer have recommended the replacement of the VFD Drives and associated motor control systems being critical components at this facility, AND

WHEREAS, it is necessary to develop detailed engineering plans, specifications and bid documents to proceed with public bidding for the installation of the replacement VFD Drives and control system modifications at said facility, NOW, THEREFORE, BE IT

RESOLVED, that the proposal of Nussbaumer & Clarke, Inc., dated March 11, 2011 as submitted to the Town Engineer for professional services for the preparation of plans, specifications and bid documents, including tasks No. 1, No. 2 and No. 3, is accepted and approved, AND, BE IT FURTHER

RESOLVED, that the Supervisor, on behalf of this Town Board, is hereby directed and authorized to sign the agreement with Nussbaumer & Clarke, Inc. for provision of said professional services, AND, BE IT FURTHER

RESOLVED, that the cost of said professional services in an amount not to exceed \$76,000.00 shall be chargeable to Account No. 255-8135-4581.

RESULT:	ADOPTED [UNANIMOUS]
MOVER:	Stanley Kaznowski, Councilmember
SECONDER:	Mary Holtz, Supervisor
AYES:	Holtz, Jaworowicz, Swiatek, Rogowski, Zydel, Kaznowski
ABSENT:	Charles Markel



15. RESOLUTION 2011-197

Authorize Supervisor to Execute Agreement with URS Corporation

Sponsored By: Supervisor Holtz, Councilmember Kaznowski

WHEREAS, the Town of Cheektowaga is in need of professional consulting engineering assistance for matters relating to mining operations, and

WHEREAS, URS Corporation has technical expertise in this matter and has submitted a proposal to perform work for the Town of Cheektowaga, NOW, THEREFORE, BE IT

RESOLVED, that this Town Board hereby retain URS Corporation to provide professional consulting engineering work to the Town of Cheektowaga as per the terms of the Agreement for General Technical Services, and BE IT FURTHER

RESOLVED, that the Supervisor be and hereby is directed to execute the Agreement for General Technical Services with URS Corporation for this project, and BE IT FURTHER

RESOLVED, that moneys for these services shall be appropriated from budget line item number 100-1320-4145.

RESULT:	ADOPTED [UNANIMOUS]
MOVER:	Mary Holtz, Supervisor
SECONDER:	Stanley Kaznowski, Councilmember
AYES:	Holtz, Jaworowicz, Swiatek, Rogowski, Zydel, Kaznowski
ABSENT:	Charles Markel



16. RESOLUTION 2011-198

Retain Outside Legal Counsel

Sponsored By: Supervisor Holtz, Councilmember Kaznowski

WHEREAS, by resolution dated December 28, 2010 (Resolution 2010-700), this Town Board retained Arthur J. Giacalone, Esq. as counsel to the Town of Cheektowaga for litigation matters relating to Buffalo Crushed Stone, Inc., and

WHEREAS, this Board needs to continue the retention of Mr. Giacalone for matters relating to Buffalo Crushed Stone, Inc. and its quarrying operations, NOW, THEREFORE, BE IT

RESOLVED, that Arthur J. Giacalone, Esq. is hereby retained by the Town of Cheektowaga to assist us on matters relating to Buffalo Crushed Stone, Inc. and its quarrying operations, and BE IT FURTHER

RESOLVED, that funds for such retention shall be appropriated from budget line item number 100.1420.4501.

RESULT:	ADOPTED [UNANIMOUS]
MOVER:	Mary Holtz, Supervisor
SECONDER:	Stanley Kaznowski, Councilmember
AYES:	Holtz, Jaworowicz, Swiatek, Rogowski, Zydel, Kaznowski
ABSENT:	Charles Markel



17. RESOLUTION 2011-199

Updated Equal Employment Opportunity Policy Statement

Sponsored By: Rogowski, Swiatek, Holtz, Jaworowicz, Zydel, Kaznowski

WHEREAS, it has always been, and continues to be, the policy of the Town of Cheektowaga to foster equality in employment and business opportunity regardless of race, color, creed, age, sex, or national origin; AND

WHEREAS, an updated declaration of the Town's position in this important employment and business issue is needed; THEREFORE, BE IT

RESOLVED, that the Town endorses the following Equal Employment Opportunity (EEO):

The Town of Cheektowaga provides equal employment opportunities to all employees and applicants for employment without regard to race, color, religion, gender, sexual orientation, national origin, age, disability, genetic information, marital status, and status as a covered veteran in accordance with applicable federal state and local laws. This policy applies to all terms and conditions of employment, including but not limited to hiring, placement, promotion, termination, layoff, recall, transfer, leaves of absence, compensation, and training.

The Town expressly prohibits any form of unlawful employee harassment based upon race, color, religion, gender, sexual orientation, national origin, age, genetic information, disability, or veteran status. Improper interference with the ability of the Town's employees to perform their expected job duties is absolutely not tolerated.

RESULT:	ADOPTED [UNANIMOUS]
MOVER:	James Rogowski, Councilmember
SECONDER:	Jeff Swiatek, Councilmember
AYES:	Holtz, Jaworowicz, Swiatek, Rogowski, Zydel, Kaznowski
ABSENT:	Charles Markel



18. RESOLUTION 2011-200

Youth & Recreation Transfers

Sponsored By: Councilmember Zydel, Councilmember Rogowski

BE IT RESOLVED that the individuals listed below be and hereby are hired and/or transferred, as indicated, in the Department of Youth & Recreational Services, effective immediately

Recreation Attendant - 7140.1640 - \$10.95 - Regular Part-time

Eric Godzich

Recreation Attendant - 7140.1636 - \$8.90 - Regular Part-time

Melisa Petre

Motion by Supervisor Holtz; Seconded by Councilmember Rogowski to waive the Reading of Names for the following Two (2) 2011-200 and 2011-201. Motion Carried.

RESULT:	ADOPTED [UNANIMOUS]
MOVER:	Richard Zydel, Councilmember
SECONDER:	James Rogowski, Councilmember
AYES:	Holtz, Jaworowicz, Swiatek, Rogowski, Zydel, Kaznowski
ABSENT:	Charles Markel



19. RESOLUTION 2011-201

Hiring/Termination of Part Time/Seasonal Employees

Sponsored By: Councilmember Swiatek, Supervisor Holtz

BE IT RESOLVED, that the following individuals be and hereby are hired as **PART-TIME EMPLOYEES** in the departments listed, not to exceed nineteen (19) hours on a weekly basis, in compliance with Civil Service Laws and Regulations as well as the provisions of the Town's collective bargaining agreement between the Town of Cheektowaga and the Town of Cheektowaga Employees Association:

SENIOR SERVICES Van Driver \$8.75/hour effective 4/5/11
Stanley P. Pinski, Jr., Cheektowaga, New York

SANITATION DEPARTMENT Laborer \$8.00/hour effective 3/21/11
Kyle B. Van Overloop, Depew, New York

BE IT RESOLVED, that the following seasonal and/or part-time employees be and hereby are terminated as listed:

SENIOR SERVICES (Van Driver)
Franklin Collins effective 3/22/11

RESULT:	ADOPTED [UNANIMOUS]
MOVER:	Jeff Swiatek, Councilmember
SECONDER:	Mary Holtz, Supervisor
AYES:	Holtz, Jaworowicz, Swiatek, Rogowski, Zydel, Kaznowski
ABSENT:	Charles Markel



20. RESOLUTION 2011-202

Travel Authorization Police Department/Lieutenant Scott Pilat and Police Officer Michael McDonough

Sponsored By: Councilmember Jaworowicz, Councilmember Swiatek

WHEREAS, the Empire State Law Enforcement Traffic Safety Conference is being held April 26 through April 27, 2011 in Syracuse, New York; AND

WHEREAS, Lieutenant Scott Pilat and Police Officer Michael McDonough have requested authorization to attend said conference; AND

WHEREAS, Police Chief David Zack has submitted a request for travel authorization along with the proper paperwork in a timely manner; AND

WHEREAS, the total cost to the Town shall not exceed \$421.57; AND

WHEREAS, these expenses have been budgeted by the Police Department; NOW, THEREFORE, BE IT

RESOLVED, that Lieutenant Scott Pilat and Police Officer Michael McDonough be and hereby are authorized to attend the Empire State Law Enforcement Traffic Safety Conference being held April 26 through April 27, 2011 in Syracuse, New York.

RESULT:	ADOPTED [UNANIMOUS]
MOVER:	Patricia Jaworowicz, Councilmember
SECONDER:	Jeff Swiatek, Councilmember
AYES:	Holtz, Jaworowicz, Swiatek, Rogowski, Zydel, Kaznowski
ABSENT:	Charles Markel



21. RESOLUTION 2011-203

Travel Authorization Police Department/Police Officer John M. Doskocz

Sponsored By: Councilmember Jaworowicz, Councilmember Swiatek

WHEREAS, the 2011 Annual K-9 Seminar is being held May 1 through May 5, 2011 in Penn Yan, New York; AND

WHEREAS, Police Officer John M. Doskocz has requested authorization to attend said seminar; AND

WHEREAS, Police Chief David Zack has submitted a request for travel authorization along with the proper paperwork in a timely manner; AND

WHEREAS, the total cost to the Town shall not exceed \$700; AND

WHEREAS, these expenses have been budgeted by the Police Department; NOW, THEREFORE, BE IT

RESOLVED, that Police Officer John M. Doskocz be and hereby is authorized to attend the 2011 Annual K-9 Seminar being held May 1 through May 5, 2011 in Penn Yan, New York.

RESULT:	ADOPTED [UNANIMOUS]
MOVER:	Patricia Jaworowicz, Councilmember
SECONDER:	Jeff Swiatek, Councilmember
AYES:	Holtz, Jaworowicz, Swiatek, Rogowski, Zydel, Kaznowski
ABSENT:	Charles Markel

V. Suspension of Rules

Motion by Councilmember Rogowski; Seconded by Supervisor Holtz to Waive the Rules to Include the Following One (1) Resolution 2011-204. Motion Carried.



1. RESOLUTION 2011-204

Appointment of Prosecuting Attorney

Sponsored By: Councilmember Swiatek, Councilmember Zydel

WHEREAS, Paul S. Piotrowski resigned from his position as Prosecutor for the Town of Cheektowaga, effective March 28, 2011, and

WHEREAS, Melissa A. Reese, Esq. has expressed an interest in serving as Prosecutor, and

WHEREAS, Melissa A. Resse, Esq. has the qualifications and experience to perform the duties of Prosecutor, and

WHEREAS, this Board has interviewed Ms. Reese and feels that she is capable of performing the duties of Prosecutor, NOW, THEREFORE, BE IT

RESOLVED, that this Town Board hereby accepts the resignation of Paul S. Piotrowski as Prosecutor for the Town of Cheektowaga, and BE IT FURTHER

RESOLVED, that Melissa A. Resse of Depew, New York be and hereby is appointed to the position of Deputy Town Attorney/Prosecuting Attorney, effective April 25, 2011 at the salary previously established for said position, and BE IT FURTHER

RESOLVED, that said appointment is contingent upon Ms. Reese being approved by the Erie County District Attorney's Office to serve as Prosecutor.

RESULT:	ADOPTED [UNANIMOUS]
MOVER:	Jeff Swiatek, Councilmember
SECONDER:	Richard Zydel, Councilmember
AYES:	Holtz, Jaworowicz, Swiatek, Rogowski, Zydel, Kaznowski
ABSENT:	Charles Markel

VI. Communications

A. Departmental Communications

1. Minutes: Cheektowaga Conservation Advisory Council - March 3, 2011
2. Building Permits - March 2011

B. General Communications

1. Notice of Claim: Sandra Barile Vs. Town of Cheektowaga
2. Notice of Claim: Jospeh Brandel, Jr. Vs. Town of Cheektowaga

3. Notice of Claim: Vince Cicchini Vs. Town of Cheektowaga
4. Notice of Claim: Donald C. Fink Vs. Town of Cheektowaga
5. Notice of Claim: Stacy L. Haas Vs. Town of Cheektowaga
6. Notice of Claim: Jimmie Johnson Vs. Town of Cheektowaga
7. Notice of Claim: Dolores Lewandowski Vs. Town of Cheektowaga

VII. Comments

A. Supervisor's Comments

B. Councilmember's Comments

C. Public Comments

VIII. Adjournment

A moment of Silence for Adolph J. "Al" Wiercioch, former Committeeman. Motion by Supervisor Holtz; Seconded by Councilmember Swiatek to adjourn the meeting at 7:08 PM.

Alice Magierski, Town Clerk



All Purchase Orders & Contracts made out to:
Please remit payment to:

PARKITECTS Inc.
138 Ludlowville Rd #1 , Lansing NY 14882
1 (800) 726-4833 • fax.(607) 533- 4108

Quotation

To: John Jaroszewski, Jr.
Town of Cheektowaga
Phone: 716-583-4274

Bill To: _____

Date: 18, March 2011

Ship To: _____

From: Ben Frasier
Ph/fax: 716-886-8647

Re: Shelter #1 Playground Equipment

Qty.	Item No.	Description	Unit Price	Amount
Equipment Under New York State Contract #PC62097				
1	Custom	EVOS Structure		\$37,645.00
1	150638A	12-Panel Mobius Climber		22,115.00
1	100050A	Arch Swing w/ Four Belt Seats		3,910.00
1	Custom	Replacement Tunnel Slide Sections w/ Hardware for PlayVenture Structure		1,435.20
1	115236A	Ball Maze Panel (All panels are for PlayVenture Structure)		945.00
1	164092A	Bongo Panel		900.00
1	115228A	Driver Panel		690.00
1	115253A	Hole Panel		510.00
1	117146A	Gear Panel		1,420.00
1	123319A	Hourglass Panel		1,110.00
1	127681A	Image Panel		1,055.00
1	123844A	Braille and Clock Panel		1,195.00
1	117957A	Periscope Panel		1,195.00
1	119514A	Pilot Panel		865.00
1	159459A	Ring-a-Bell Panel		1,080.00
1	123483A	Space Panel		1,010.00
1	115231A	Tic Tac Toe Panel		1,090.00
1	115227A	Zoo Panel		515.00
		Equipment Subtotal		\$78,685.20
		Less NY State Contract Discount		(1,573.70)
		Freight (4,000.00)		NC
		Equipment Total		\$77,111.50

Attachment: Parkitects (RES-2011-193 : Purchase Play Equipment for Stiglmeier Park)

Accepted By Customer _____ Date _____
Print Name
Ben Frasier
Proposal By Parkitects Representative

Terms: Net 30

Purchaser is responsible for sales tax unless a certificate of exemption is included with order.



Town of Cheektowaga

Regular Meeting

~ Minutes ~

3301 Broadway
Cheektowaga, NY 14227

<http://www.town.cheektowaga.ny.us>

Alice Magierski
716-686-3400

Monday, April, 18, 2011

6:45 PM

Council Chambers

I. Call to Order

6:45 PM Meeting called to order on April 18, 2011 at Council Chambers, 3301 Broadway St, Cheektowaga, NY.

Attendee Name	Organization	Title	Status	Arrived
Mary Holtz	Town of Cheektowaga	Supervisor	Present	
Patricia Jaworowicz	Town of Cheektowaga	Councilmember	Present	
Jeff Swiatek	Town of Cheektowaga	Councilmember	Present	
James Rogowski	Town of Cheektowaga	Councilmember	Present	
Richard Zydel	Town of Cheektowaga	Councilmember	Absent	
Charles Markel	Town of Cheektowaga	Councilmember	Present	
Stanley Kaznowski	Town of Cheektowaga	Councilmember	Absent	

2. Additional Attendees

Thomas Adamczak, Supervising Building and Plumbing Inspector
Ellen Fischer, Executive Director - Youth Board
Brian Krause, Director of Finance and Administration
John Marriott, Planning Board Chairman
William Pugh, Town Engineer
Kevin Schenk, Town Attorney
David Zack, Chief of Police

II. Public Comment Period

III. Resolutions



1. RESOLUTION 2011-208

Transfer of Funds

Sponsored By: Supervisor Holtz, Councilmember Swiatek

BE IT RESOLVED, that the following transfer is hereby approved and made a part hereof;

GENERAL FUND

FROM:	100.1410.1971	Part-time Regular	\$	500.00
	100.7140.2134	Public Skate		448.50
	100.1910.2680	Insurance Recoveries		381.38
	100.1110.2770	Other Unclassified Revenues		29,949.40
TO:	100.1410.1902	Overtime Payroll	\$	500.00
	100.7110.1902	Overtime Payroll		448.50
	100.3310.4471	Traffic-Signs/Street Markings		381.38
	100.1110.2105	Equipment		29,949.40

SPECIAL DISTRICTS FUND

FROM:	990.1910.2681	Light Standard Damages	\$	840.00
	990.1910.2681	Light Standard Damages		1,945.00
TO:	990.5182.4432	Repairs & Maintenance	\$	840.00
	990.5182.4432	Repairs & Maintenance		1,945.00

RESULT:	ADOPTED [UNANIMOUS]
MOVER:	Mary Holtz, Supervisor
SECONDER:	Jeff Swiatek, Councilmember
AYES:	Holtz, Jaworowicz, Swiatek, Rogowski, Markel
ABSENT:	Richard Zydel, Stanley Kaznowski



2. RESOLUTION 2011-209

Warrant

Sponsored By: Supervisor Holtz, Councilmember Swiatek

BE IT RESOLVED, that the following Vouchers & Warrants submitted to the Town of Cheektowaga prior to April 15, 2011 are hereby approved and made a part hereof;

GENERAL FUND	\$ 2,899,207.81
RISK RETENTION FUND	206,172.17
HUD HOUSING REHABILITATION FUND	16,700.19
SPECIAL DISTRICTS FUND	1,912,213.32
HIGHWAY FUND	516,406.47
CAPITAL FUND	386,196.65
TRUST & AGENCY FUND	4,994.85
HUD CDBG FUND	44,907.02
PART TOWN FUND	155,565.26
NYS AFFORDABLE HOUSING	1,813.00
	<u>\$ 6,144,176.74</u>

RESULT:	ADOPTED [UNANIMOUS]
MOVER:	Mary Holtz, Supervisor
SECONDER:	Jeff Swiatek, Councilmember
AYES:	Holtz, Jaworowicz, Swiatek, Rogowski, Markel
ABSENT:	Richard Zydel, Stanley Kaznowski



3. RESOLUTION 2011-210

Award of Bid - Trees

Sponsored By: Supervisor Holtz, Councilmember Rogowski

WHEREAS, a Notice to Bidders was published for the receipt of bids for the furnishing and installation of various trees to be planted at the Town Hall Campus, which bids were duly received and opened on April 6, 2011, AND

WHEREAS, said bids were referred to the Town Engineer for analysis and tabulation, NOW, THEREFORE, BE IT

RESOLVED, that the contract for the furnishing and installation of various trees at the Town Hall Campus be awarded to J & C Landscaping, 8519 Ertman Road, Lockport, New York 14094 for the bid price of \$23,555.00, said being the lowest bid meeting the requirements of the specifications, AND, BE IT FURTHER

RESOLVED, that the Supervisor, on behalf of this Town Board, be and hereby is authorized and directed to execute a contract with J & C Landscaping, AND, BE IT FURTHER

RESOLVED, that funding for said project shall be appropriated from Account No. 500-1440-2061-5835.

RESULT:	ADOPTED [UNANIMOUS]
MOVER:	Mary Holtz, Supervisor
SECONDER:	James Rogowski, Councilmember
AYES:	Holtz, Jaworowicz, Swiatek, Rogowski, Markel
ABSENT:	Richard Zydel, Stanley Kaznowski



4. RESOLUTION 2011-211

Award of Bid - Ford Expedition Vehicle

Sponsored By: Councilmember Jaworowicz, Councilmember Rogowski

WHEREAS, bids were duly received by the Town Clerk at a bid opening on March 30, 2011, for the purchase of one (1) new and unused 2011 Ford Expedition Special Service Vehicle by the Town of Cheektowaga Police Department, and said bids were referred to the Cheektowaga Police Department for analysis, tabulation and report; AND

WHEREAS, such analysis, tabulation and report has been completed, NOW, THEREFORE, BE IT

RESOLVED, that the bid for the purchase of said vehicle be awarded to Basil Ford, 1540 Walden Avenue, Cheektowaga, NY 14225, for the purchase price of \$27,238.00, said bid being the lowest responsible bid meeting all specifications; AND, BE IT FURTHER

RESOLVED, that funds for the purchase of this vehicle shall be appropriated from line item number #100-3120-2303.

RESULT:	ADOPTED [UNANIMOUS]
MOVER:	Patricia Jaworowicz, Councilmember
SECONDER:	James Rogowski, Councilmember
AYES:	Holtz, Jaworowicz, Swiatek, Rogowski, Markel
ABSENT:	Richard Zydel, Stanley Kaznowski



5. RESOLUTION 2011-212

Award of Bid - 2011 Pool Maintenance Chemicals

Sponsored By: Councilmember Rogowski, Councilmember Jaworowicz

WHEREAS, sealed bids were received for Pool Maintenance Chemicals on March 21, 2011 at a meeting held for said purpose, AND

WHEREAS, said bids have been reviewed for in compliance under the terms of the specifications, NOW THEREFORE BE IT

RESOLVED, that the Cheektowaga Town Board hereby award said Bid for Pool Maintenance Chemicals to:

Bison Laboratories, Inc.
100 Leslie Street
Buffalo, NY 14211

FOR

Category I - Bromine - \$2.54 per lb.

Amrex Chemical Co., Inc.
391 Exchange Street
Buffalo, NY 14204

FOR

Category II - Diatomaceous Earth - \$.36 per lb.
Sodium Bicarbonate - \$.28 per lb.
Soda Ash - \$.28 per lb.

RESULT:	ADOPTED [UNANIMOUS]
MOVER:	James Rogowski, Councilmember
SECONDER:	Patricia Jaworowicz, Councilmember
AYES:	Holtz, Jaworowicz, Swiatek, Rogowski, Markel
ABSENT:	Richard Zydel, Stanley Kaznowski



6. RESOLUTION 2011-213

Award of Bid - Two (2) Sets of Completely Installed and Operational, Front Snow Plows, Wing Plows, Plow Rigging, Hydraulics, Dump Bodies and Accessories

Sponsored By: Councilmember Swiatek, Supervisor Holtz

WHEREAS, bids were received and opened by the Town Clerk at a public bid opening held on April 6, 2011, for Two (2) sets of Completely Installed and operational, Front Snow Plows, Wing Plows, Plow Rigging, Hydraulics, Dump Bodies and Accessories for use by the Town of Cheektowaga Highway Department as a result of advertisement thereof, and such bid was referred to the Superintendent of Highway for Analysis, tabulation and reports, AND

WHEREAS, bids were analyzed and completed, NOW THEREFORE BE IT

RESOLVED, the responsible bidder meeting specs for Two (2) Sets of Completely Installed and Operational, Front Snow Plows, Wing Plows, Plow Rigging, Hydraulics, Dump Bodies and Accessories be awarded to Viking Cives, 14331 Mill Street, Harrisville, NY 13648 at a total bid price of \$155,200.00 said bidder meeting specifications of bid. AND, BE IT FURTHER

RESOLVED, that monies be charged to line items 300-5130-2407.

TABULATION FOR TWO (2) SETS OF COMPLETELY INSTALLED AND OPERATIONAL, FRONT SNOW PLOWS, WING PLOWS, PLOW RIGGING, HYDRAULICS, DUMP BODIES AND ACCESSORIES

Valley Fab & Equipment, Inc.
9776 Trevett Road
Boston, NY 14025

\$153,200.00

Viking Cives
14331 Mill Street
Harrisville, NY 13648

\$155,200.00

Please make note that even though Valley Fab & Equipment, Inc. has the lower bid, the award is going to Viking Cives, due to the facts that Valley Fab was not able to meet bid specs. Viking was able to meet the bid specs offering the necessary quality of the items in the bid.

RESULT:	ADOPTED [UNANIMOUS]
MOVER:	Jeff Swiatek, Councilmember
SECONDER:	Mary Holtz, Supervisor
AYES:	Holtz, Jaworowicz, Swiatek, Rogowski, Markel

ABSENT: Richard Zydel, Stanley Kaznowski



7. RESOLUTION 2011-214

Award of Bid - Demolition of 1112 Walden Avenue

Sponsored By: Councilmember Markel, Councilmember Rogowski

WHEREAS, bids were advertised for the furnishing of equipment, operators and laborers for the demolition of a mixed commercial-residential building located at 1112 Walden Avenue, and

WHEREAS, bid proposals were received and opened on April 13, 2011 for said demolitions, and

WHEREAS, the proposals were reviewed by the Town Attorney and, based on proposals submitted, the Town Attorney has recommended that this Town Board award the bid for the demolition of the property located at 1112 Walden Avenue to Hannah Demolition, Inc., NOW, THEREFORE, BE IT

RESOLVED, that this Town Board hereby awards the bid for the demolition (controlled) of 1112 Walden Avenue to:

Hannah Demolition, Inc.
205 Baitz Avenue
Buffalo, NY 14206

for the bid price of \$18,200.00, being the lowest responsible bid meeting specifications, and BE IT FURTHER

RESOLVED, that the Supervisor be and hereby is directed to execute an agreement with Hannah Demolition, Inc. for the aforesaid services, and BE IT FURTHER

RESOLVED, that moneys for said services shall be appropriated from budget line item number 0800-800-0440.

RESULT:	ADOPTED [UNANIMOUS]
MOVER:	Charles Markel, Councilmember
SECONDER:	James Rogowski, Councilmember
AYES:	Holtz, Jaworowicz, Swiatek, Rogowski, Markel
ABSENT:	Richard Zydel, Stanley Kaznowski



8. RESOLUTION 2011-215

Award of Bid - Demolition of 2371 Genesee Street

Sponsored By: Councilmember Markel, Councilmember Rogowski

WHEREAS, bids were advertised for the furnishing of equipment, operators and laborers for the demolition of a commercial building located at 2371 Genesee Street, and

WHEREAS, bid proposals were received and opened on April 13, 2011 for said demolitions, and

WHEREAS, the proposals were reviewed by the Town Attorney and, based on proposals submitted, the Town Attorney has recommended that this Town Board award the bid for the demolition of the property located at 2371 Genesee Street to Hannah Demolition, Inc., NOW, THEREFORE, BE IT

RESOLVED, that this Town Board hereby awards the bid for the demolition (controlled) of 2371 Genesee Street to:

Hannah Demolition, Inc.
205 Baitz Avenue
Buffalo, NY 14206

for the bid price of \$22,635.00, being the lowest responsible bid meeting specifications, and BE IT FURTHER

RESOLVED, that the Supervisor be and hereby is directed to execute an agreement with Hannah Demolition, Inc. for the aforesaid services, and BE IT FURTHER

RESOLVED, that moneys for said services shall be appropriated from budget line item number 0800-800-0440.

RESULT:	ADOPTED [UNANIMOUS]
MOVER:	Charles Markel, Councilmember
SECONDER:	James Rogowski, Councilmember
AYES:	Holtz, Jaworowicz, Swiatek, Rogowski, Markel
ABSENT:	Richard Zydel, Stanley Kaznowski



9. RESOLUTION 2011-216

Award of Bid - Police Department Pistols

Sponsored By: Councilmember Jaworowicz, Councilmember Rogowski

WHEREAS, one bid was duly received by the Town Clerk at a bid opening on April 13, 2011 for the purchase of One hundred thirty two (132) Model 22 Generation 4 Glock Pistols with fixed sights and three (3) Magazines, and Fourteen (14) Model 23 Generation 4 Glock Pistols with fixed sights and three (3) Magazines, with trade-in of 145 Glock Model 22 1st Generation pistols; said bid was referred to the Cheektowaga Police Department for analysis, tabulation and report; and

WHEREAS, such analysis, tabulation and report has been completed; NOW,
THEREFORE BE IT

RESOLVED, that said bid be awarded to OMB Guns, 15765 S. Keeler St, Olathe, Kansas, 66062, for the purchase price of \$12,247.00, said sole bid meeting specifications; and
BE IT FURTHER

RESOLVED, that funding for these items shall be appropriated from Police Department Asset Forfeiture account number 600-0600-0881.

RESULT:	ADOPTED [UNANIMOUS]
MOVER:	Patricia Jaworowicz, Councilmember
SECONDER:	James Rogowski, Councilmember
AYES:	Holtz, Jaworowicz, Swiatek, Rogowski, Markel
ABSENT:	Richard Zydel, Stanley Kaznowski



10. RESOLUTION 2011-217

Order Calling for Public Hearing to Install Curbing Along North Meadowbrook Parkway

Sponsored By: Supervisor Holtz, Councilmember Swiatek

WHEREAS, a written petition dated March 26, 2011 was heretofore presented and filed with the Town Board of the Town of Cheektowaga pursuant to Section 200 of the Town Law of the State of New York, praying for the improvement of the following portion of North Meadowbrook Parkway (the area benefited by said improvement):

ALL THAT TRACT OR PARCEL OF LAND, situate in the Town of Cheektowaga, County of Erie and State of New York, being part of Lot No. 147, Township 10, Range 7 of the Buffalo Creek Reservation, generally described as follows:
North Meadowbrook Parkway, both sides, from the north side of Dingens Street to the north side of Bismarck Street.

by the construction and installation of curbing and other necessary related improvements in connection therewith along the entire length on both sides of the portion of North Meadowbrook Parkway described above, and

WHEREAS, said petition has been signed by the owners of real estate fronting or abutting upon either side of the portion of North Meadowbrook Parkway to be improved, to the extent of at least one-half of the entire frontage or bounds on both sides of the portion of said street to be improved, and the resident owners owing not less than one-half of the frontage owned by resident owners residing in or along the portion of said street covered or represented by said petition, and

WHEREAS, said petition was duly acknowledged or proved by all signers thereof in the same manner as a deed to be recorded, and

WHEREAS, the maximum amount proposed to be expended for the improvement of the portion of said street as stated in the petition is \$47,120.00, and

WHEREAS, the petition provided that the expense of the construction of said improvement shall be borne by local assessment upon the several parcels of land especially benefited thereby all as stated in said petition and as more fully provided by applicable law, NOW, THEREFORE, BE IT

ORDERED, that a meeting of the Town Board of the Town of Cheektowaga be held at the Cheektowaga Town Hall, 3301 Broadway, in said Town on the 2nd day of May, 2011 at 6:45 p.m. to consider the said petition and to hear all persons interested in the subject thereof concerning the same, and for such other action on the part of the Town Board with relation to the Petition as maybe required by law, and BE IT FURTHER

ORDERED, that a copy of this Order, certified by the Town Clerk, be published as least once in the CHEEKTOWAGA BEE, the official Town newspaper, and posted on the signboard maintained pursuant to subdivision 6 of Section 30 of the Town Law, and conspicuously in five (5) public places along the portion of North Meadowbrook Parkway, the first publication thereof and posting to be not less than ten (10) nor more than twenty (20) days before the date of such

public hearing.

RESULT:	ADOPTED [UNANIMOUS]
MOVER:	Mary Holtz, Supervisor
SECONDER:	Jeff Swiatek, Councilmember
AYES:	Holtz, Jaworowicz, Swiatek, Rogowski, Markel
ABSENT:	Richard Zydel, Stanley Kaznowski



11. RESOLUTION 2011-218

Authorize Purchase of Land from Maryvale School District

Sponsored By: Holtz, Markel, Jaworowicz, Rogowski

WHEREAS, the Town of Cheektowaga, for the past 25-30 years, has operated the Maryvale Pool and Winston-Vegola Playground on land owned by the Cheektowaga-Maryvale Union Free School District pursuant to an agreement, and

WHEREAS, recently, the Cheektowaga-Maryvale Union Free School District sold the land and building adjacent to the Maryvale Pool, and no longer wishes to retain title to the lands underlying the Maryvale Pool and Winston-Vegola Playground, and

WHEREAS, the Cheektowaga-Maryvale Union Free School District offered said lands for sale to the Town of Cheektowaga, and

WHEREAS, the Town of Cheektowaga and Cheektowaga-Maryvale Union Free School District negotiated a deal whereby the Town of Cheektowaga would purchase the lands where the Maryvale Pool and Winston-Vegola Playground are situated for \$60,000.00 over five (5) years, and

WHEREAS, the attorney for the Cheektowaga-Maryvale Union Free School District has prepared a contract for the purchase of this property, and said contract has been reviewed and approved by the Town Attorney, NOW, THEREFORE, BE IT

RESOLVED, that the Supervisor be and hereby is authorized and directed to execute this contract on behalf of the Town of Cheektowaga, and BE IT FURTHER

RESOLVED, that moneys for the purchase of this property shall be appropriated from budget line item number 100-7180-2055.

RESULT:	ADOPTED [4 TO 0]
MOVER:	Mary Holtz, Supervisor
SECONDER:	Charles Markel, Councilmember
AYES:	Mary Holtz, Patricia Jaworowicz, James Rogowski, Charles Markel
ABSTAIN:	Jeff Swiatek
ABSENT:	Richard Zydel, Stanley Kaznowski



12. RESOLUTION 2011-219

Authorize Sale of 36 Euclid

Sponsored By: Councilmember Markel, Councilmember Swiatek

WHEREAS, the Town of Cheektowaga is the owner of vacant lot located at 36 Euclid Avenue in the Town, and

WHEREAS, said property is excess to the needs of the Town, and

WHEREAS, the Town of Cheektowaga received an offer to purchase said parcel for \$500.00, and

WHEREAS, the Director of Community Development has recommended that the Town accept this offer, NOW, THEREFORE, BE IT

RESOLVED, that the Supervisor be and hereby is authorized and directed to execute a contract and other documents necessary to effectuate the sale of 36 Euclid Avenue for \$500.00, and BE IT FURTHER

RESOLVED, that the sale of 36 Euclid Avenue is subject to permissive referendum under the Town Law of the State of New York, and BE IT FURTHER

RESOLVED, that the Town Clerk be and hereby is directed to file the attached Notice of adoption of Resolution Subject to Permissive Referendum on the CHEEKTOWAGA BEE, the Town's official newspaper.

NOTICE OF ADOPTION OF RESOLUTION SUBJECT TO PERMISSIVE REFERENDUM

NOTICE IS HEREBY GIVEN, that the Town Board of the Town of Cheektowaga, on April 18, 2011, adopted a resolution authorizing the Town of Cheektowaga to sell vacant property located at 36 Euclid Avenue, Cheektowaga, New York for \$500.00.

A copy of such resolution and offer are on file in the Town Clerk's Office where the same may be viewed during regular business hours.

TAKE FURTHER NOTICE, that such resolution is subject to permissive referendum under Article 7 of the Town Law of the State of New York.

BY ORDER OF THE TOWN BOARD OF THE TOWN OF CHEEKTOWAGA, ERIE COUNTY, NEW YORK

DATED: April 18, 2011

ALICE MAGIERSKI
Town Clerk

Attachments:

36 Euclid - Purchase Offer (PDF)

RESULT: **ADOPTED [UNANIMOUS]**
MOVER: Charles Markel, Councilmember
SECONDER: Jeff Swiatek, Councilmember
AYES: Holtz, Jaworowicz, Swiatek, Rogowski, Markel
ABSENT: Richard Zydel, Stanley Kaznowski



13. RESOLUTION 2011-220

Agreement with Auctions International, Inc.

Sponsored By: Councilmember Rogowski, Supervisor Holtz

WHEREAS, the Town wishes to dispose of a number of surplus motor vehicles and equipment no longer needed for Town use: and

WHEREAS, sale of surplus property by the Town is authorized by Section 64 of the Town Law of the State of New York; and

WHEREAS, Auctions International, Inc., will sell such motor vehicles and equipment at an on-line auction in accordance with the terms of a proposed agreement, a copy of which is attached hereto; NOW THEREFORE, BE IT

RESOLVED, that the Town hereby retains Auctions International, Inc., 808 Borden Road, Cheektowaga, New York, as per the submitted agreement, to conduct a sale of the surplus Town vehicles and equipment identified as follows at an on-line auction to be held on its website; and BE IT FURTHER

RESOLVED, that the Supervisor of the Town of Cheektowaga be and hereby is authorized to execute the aforementioned agreement and any and all documents that may be required to effectuate the sale and transfer of said vehicles and equipment.

VEHICLES

<i>Number</i>	<i>Year/Make/Model</i>	<i>VIN#</i>	<i>Department</i>
129	1986 Ford Tractor 6610	C761012	Facilities/Parks
107	1985 Ford Tractor 2910	C744246	Facilities/Parks
130	1989 Ford Tractor 4610	BC24150	Facilities/Parks

EQUIPMENT

Copy Machine -Cannon Image Runner 1330 Main Pump Station
HP Scanjet 5 Document Scanner Main Pump Station

HP DesignJet 750C Printer Engineering
HP DesignJet 350C Printer Engineering

SA Sport Gymnastic Ring Frame Youth & Recreation
Gibson Gymnastic Preschool Bar Youth & Recreation
Konica Minolta Bizhub 600 Copier Youth & Recreation

RESULT: **ADOPTED [UNANIMOUS]**
MOVER: James Rogowski, Councilmember

SECONDER: Mary Holtz, Supervisor
AYES: Holtz, Jaworowicz, Swiatek, Rogowski, Markel
ABSENT: Richard Zydel, Stanley Kaznowski



14. RESOLUTION 2011-221

Agreement with Catholic Charities (YES Program)

Sponsored By: Councilmember Rogowski, Supervisor Holtz

WHEREAS, the Cheektowaga Department of Youth and Recreational Services is desirous of continuing the operation of the Youth Engaged in Service (Y.E.S.) program with Catholic Charities of Buffalo Metropolitan Services Department, 525 Washington Street, Buffalo, New York, AND

WHEREAS, said program, which prepares and provides teenagers with opportunities to assist their community in various projects that have a need for volunteers and is open to all Cheektowaga youth regardless of race, color, or creed, NOW, THEREFORE, BE IT

RESOLVED that subject to approval by the Town Attorney the Supervisor of the Town of Cheektowaga be and hereby is directed to execute an agreement between the Town of Cheektowaga and Catholic Charities of Buffalo Metropolitan Services Department to continue said program for a twelve month period, Retroactive to January 1, 2011 through December 31, 2011 with a total payment to Catholic Charities not to exceed the sum of \$73,184.00.

CONTRACT # (BUDGET LINE ITEM) 01-7310-4685

RESULT:	ADOPTED [UNANIMOUS]
MOVER:	James Rogowski, Councilmember
SECONDER:	Mary Holtz, Supervisor
AYES:	Holtz, Jaworowicz, Swiatek, Rogowski, Markel
ABSENT:	Richard Zydell, Stanley Kaznowski



15. RESOLUTION 2011-222

Agreement with Catholic Charities (SIS)

Sponsored By: Councilmember Rogowski, Supervisor Holtz

WHEREAS, the Cheektowaga Department of Youth and Recreational Services is desirous of continuing the operation of a joint program with Catholic Charities of Buffalo Metropolitan Services Department, 525 Washington Street, Buffalo, New York, 14203, whereby high risk youth within the Town will receive individual and family counseling through the School Intervention Service, AND

WHEREAS, said program is open to all Cheektowaga youth regardless of race, color, or creed, NOW, THEREFORE, BE IT

RESOLVED that the Supervisor of the Town of Cheektowaga be and hereby is directed to execute an agreement between the Town of Cheektowaga and Catholic Charities of Buffalo Metropolitan Services Department, to continue said program for a twelve month period, January 1, 2011 through December 31, 2011 with a total cost not to exceed \$183,028.00 and BE IT FURTHER

RESOLVED that Catholic Charities of Buffalo Metropolitan Services will reimburse the Town \$42,756.00 of the total budget for said program and the New York State Office of Children and Family Services will reimburse the Town for up to \$22,833.00 leaving the actual cost to the Town at \$117,439.00

CONTRACT # (BUDGET LINE ITEM) 01-7310-4677

RESULT:	ADOPTED [UNANIMOUS]
MOVER:	James Rogowski, Councilmember
SECONDER:	Mary Holtz, Supervisor
AYES:	Holtz, Jaworowicz, Swiatek, Rogowski, Markel
ABSENT:	Richard Zydel, Stanley Kaznowski



16. RESOLUTION 2011-223

Agreement with Child & Family Services 2011

Sponsored By: Councilmember Rogowski, Supervisor Holtz

RESOLVED that the Supervisor of the Town of Cheektowaga be and hereby is directed to execute an agreement between the Town of Cheektowaga and Child and Family Services 330 Delaware Avenue, Buffalo, New York, 14202 for the period of January 1, 2011 to March 31, 2011 with a total cost not to exceed \$36,528.00 and BE IT FURTHER

RESOLVED that this payment will terminate the relationship between the Cheektowaga Department of Youth & Recreational Services and Child and Family Services immediately.

CONTRACT # (BUDGET LINE ITEM) 01-7310-4687

RESULT:	ADOPTED [UNANIMOUS]
MOVER:	James Rogowski, Councilmember
SECONDER:	Mary Holtz, Supervisor
AYES:	Holtz, Jaworowicz, Swiatek, Rogowski, Markel
ABSENT:	Richard Zydel, Stanley Kaznowski



17. RESOLUTION 2011-224

Special Event- Crabapple Festival

Sponsored By: Supervisor Holtz, Councilmember Rogowski

WHEREAS, by resolution dated May 1, 1995, this Town Board adopted a Special Events policy, which requires anyone wishing to hold a special event in the Town to file an application and supporting documentation, fees, etc. to the Town Clerk prior to the special event; and

WHEREAS, Supervisor Mary Holtz has made application to hold the Crabapple Festival - Celebration of the Town of Cheektowaga June 10th, 11th, and 12th, 2011; and

WHEREAS, this Board has reviewed the aforementioned application, which application has been approved by the Parks Department and the Department of Recreation & Youth Services, and has no objection to same; and

WHEREAS, due to the nature of the event, this Town Board hereby waives the following requirements:

- Submittal of plan for sanitary facilities;
- Submittal of site plan;
- Submittal of Security Plan;
- Submittal of Fire Prevention/Emergency Services Plan;
- Certificate of Insurance from Cheektowaga Patriotic Commission;

NOW, THEREFORE, BE IT

RESOLVED, that this Town Board hereby approves the aforementioned application of Supervisor Mary Holtz for the aforementioned Crabapple Festival - Celebration of the Town of Cheektowaga to be held on June 10-12, 2011.

RESULT:	ADOPTED [UNANIMOUS]
MOVER:	Mary Holtz, Supervisor
SECONDER:	James Rogowski, Councilmember
AYES:	Holtz, Jaworowicz, Swiatek, Rogowski, Markel
ABSENT:	Richard Zydell, Stanley Kaznowski



18. RESOLUTION 2011-225

Special Event - Cheektowaga Amateur Athletic Association

Sponsored By: Councilmember Rogowski, Councilmember Swiatek

WHEREAS, by resolution dated May 1, 1995, this Town Board adopted a Special Events policy, which requires anyone wishing to hold a special event in the Town to file an application and supporting documentation, fees, etc. to the Town Clerk prior to the special event; and

WHEREAS, the North Cheektowaga Amateur Athletic Association has made application to hold its baseball parade on Saturday, June 4, 2011 beginning at 12:00 noon, said parade to begin on Nagel Drive, to George Urban Drive ending at the Tops Plaza; and

WHEREAS, this Board has reviewed the aforementioned application, which application has been approved by the Police Department, the Department of Youth and Recreation, and the and Facilities Department, and has no objection to same; and

WHEREAS, due to the nature of the event, this Town Board hereby waives the following requirements:

1. Submittal of plan for sanitary facilities;
2. Submittal of site plan;
3. Requirement that application be made at least 60 days prior to the date of the special event;
4. Submittal of Security Plan;
5. Submittal of Fire Prevention/Emergency Services Plan;

NOW, THEREFORE, BE IT

RESOLVED, that this Town Board hereby approves the application of North Cheektowaga Amateur Athletic Association for the aforementioned Parade, to be held on Saturday, June 4, 2011 at 12:00 P.M.; BE IT FURTHER

RESOLVED, that the Chief of Police be and hereby is directed to provide traffic safety and escort services for such parade and to ensure compliance with Section 1660(a)(6) of the Vehicle and Traffic Law.

RESULT:	ADOPTED [UNANIMOUS]
MOVER:	James Rogowski, Councilmember
SECONDER:	Jeff Swiatek, Councilmember
AYES:	Holtz, Jaworowicz, Swiatek, Rogowski, Markel
ABSENT:	Richard Zydel, Stanley Kaznowski



19. RESOLUTION 2011-226

Purchase of Rake Carriage Assembly

Sponsored By: Supervisor Holtz, Councilmember Swiatek

WHEREAS, the Main Pump Station has requested authorization to purchase one (1) Rake Carriage Assembly and related parts, AND

WHEREAS, this equipment is manufactured by WSG & Solutions, being the sole source supplier, NOW, THEREFORE, BE IT

RESOLVED, that the purchase of one (1) Rake Carriage Assembly and related parts be awarded to:

WSG & Solutions
160 Commerce Drive
Suite 100
Montgomeryville, PA 18936

in the amount of \$15,550.60, AND, BE IT FURTHER

RESOLVED, that funds have been budgeted from Account No. 255-8135-4431 for said purchase.

RESULT:	ADOPTED [UNANIMOUS]
MOVER:	Mary Holtz, Supervisor
SECONDER:	Jeff Swiatek, Councilmember
AYES:	Holtz, Jaworowicz, Swiatek, Rogowski, Markel
ABSENT:	Richard Zydel, Stanley Kaznowski



20. RESOLUTION 2011-227

Maryvale Pep Grant

Sponsored By: Councilmember Rogowski, Councilmember Markel

WHEREAS, the Maryvale Union Free School District is submitting a grant application to the U.S. Department of Education's Carol M. White Physical Education Program to enhance physical education programs both during and after the school day and,

WHEREAS, the district wishes to establish a partnership with the Town and other community based organizations to work toward improving the health and wellness of its students, NOW, THEREFORE, BE IT

RESOLVED that the Supervisor or her designee be authorized to sign a Partner Agreement with the Maryvale Union Free School in preparation for submittal of a Carol M. White Physical Education Program grant.

RESULT:	ADOPTED [UNANIMOUS]
MOVER:	James Rogowski, Councilmember
SECONDER:	Charles Markel, Councilmember
AYES:	Holtz, Jaworowicz, Swiatek, Rogowski, Markel
ABSENT:	Richard Zydel, Stanley Kaznowski



21. RESOLUTION 2011-228

Approve Modification of Storm Sewer Easement

Sponsored By: Supervisor Holtz, Councilmember Markel

WHEREAS, in 2002, Derrick Corporation granted the Town of Cheektowaga a storm sewer easement over its property located at 590 Duke Road in the Town of Cheektowaga, and

WHEREAS, said easement was recorded in the Erie County Clerk's Office on November 20, 2002 in Liber 11019 of Deeds at Page 7386, and

WHEREAS, Derrick Corporation is in the process of expanding its facility with an addition to its building, and has requested that the Town of Cheektowaga modify this easement, and

WHEREAS, plans for said expansion and easement modification has been reviewed and approved by the Town Engineer, and

WHEREAS, the Town Attorney has prepared a Modification of Easement document for approval by this Board, NOW, THEREFORE, BE IT

RESOLVED, that this Town Board hereby approves the aforementioned Modification of Easement, and authorizes and directs the Town Supervisor to execute said document.

RESULT:	ADOPTED [UNANIMOUS]
MOVER:	Mary Holtz, Supervisor
SECONDER:	Charles Markel, Councilmember
AYES:	Holtz, Jaworowicz, Swiatek, Rogowski, Markel
ABSENT:	Richard Zydel, Stanley Kaznowski



22. RESOLUTION 2011-229

Approve Release of Storm Sewer Easement

Sponsored By: Supervisor Holtz, Councilmember Markel

WHEREAS, the Town of Cheektowaga was granted a storm sewer easement by Celukim, Inc. across property then known as 600 Duke Road in the Town, which was recorded in the Erie County Clerk's Office on August 29, 1979 in Liber 8824 of Deeds at Page 632, and

WHEREAS, Derrick Corporation recently acquired this property for expansion of its existing building, and has requested that the Town of Cheektowaga discharge and release this easement, and

WHEREAS, as a result of drainage work done in connection with the reconstruction of Walden Avenue at Union Road by the State, the Town Engineer has stated that this storm sewer easement is longer needed by the Town, and

WHEREAS, the Town Attorney has prepared a Release and Discharge of Easement document for approval by this Board, NOW, THEREFORE, BE IT

RESOLVED, that this Town Board hereby approves the aforementioned Release and Discharge of Easement, and authorizes and directs the Town Supervisor to execute said document, and BE IT FURTHER

RESOLVED, that this resolution is subject to permissive referendum under Article 7 of the Town Law, and BE IT FURTHER

RESOLVED, that the Town Clerk be and hereby is directed to publish the attached Notice of Adoption of Resolution Subject to Permissive Referendum in the Cheektowaga Bee.

NOTICE OF ADOPTION OF RESOLUTION
SUBJECT TO PERMISSIVE REFERENDUM

NOTICE IS HEREBY GIVEN, that the Town Board of the Town Of Cheektowaga, on April 18, 2011, adopted a resolution authorizing the Town Of Cheektowaga to release and discharge a storm sewer easement located along a portion of Duke Road/Walden Avenue west of Union Road in the Town of Cheektowaga.

A copy of such Release and Discharge of Easement is on file in the Town Clerk's Office where the same may be viewed during regular business hours.

TAKE FURTHER NOTICE, that such resolution is subject to permissive referendum under Article 7 of the Town Law of the State of New York.

BY ORDER OF THE TOWN BOARD OF THE TOWN OF CHEEKTOWAGA, ERIE COUNTY, NEW YORK.

Dated: April 18, 2011

ALICE MAGIERSKI,

Town Clerk

RESULT:	ADOPTED [UNANIMOUS]
MOVER:	Mary Holtz, Supervisor
SECONDER:	Charles Markel, Councilmember
AYES:	Holtz, Jaworowicz, Swiatek, Rogowski, Markel
ABSENT:	Richard Zydel, Stanley Kaznowski



23. RESOLUTION 2011-230

Creation of Planner Title

Sponsored By: Councilmember Swiatek, Supervisor Holtz

BE IT RESOLVED, that this Town Board hereby creates the position of Planner pursuant to Civil Service Laws and Rules effective April 19, 2011.

RESULT:	ADOPTED [UNANIMOUS]
MOVER:	Jeff Swiatek, Councilmember
SECONDER:	Mary Holtz, Supervisor
AYES:	Holtz, Jaworowicz, Swiatek, Rogowski, Markel
ABSENT:	Richard Zydel, Stanley Kaznowski



24. RESOLUTION 2011-231

Youth & Recreation Hires

Sponsored By: Councilmember Rogowski, Councilmember Swiatek

BE IT RESOLVED that the individuals listed below be and hereby are hired and/or transferred, as indicated, in the Department of Youth & Recreational Services, effective immediately:

Cheektowaga Conservation Corps (CCC)

Seasonal

Laborer - "Crew Supervisor - Level IV" - 7310.1811 - \$13.00

Andrew Swiat 14227

Laborer - "Youth Leader - Level III" - 7310.1811 - \$9.65

Stephen Pfalzer 14043

Laborer - "Youth Leader - Level IV" - 7310.1811 - \$10.00

Brian Sheldon 14227

Recreation Attendant - 7140.1636 - \$7.25 - Regular Part-time

Kaylia Mergenthaler 14225

Recreation Attendant - 7140.1614 - \$7.50 - Seasonal

Harley Wiertel 14227

Kendal Wiertel 14227

Motion by Supervisor Holtz; Seconded by Councilmember Rogowski to Waive the Reading of Names for the following Two (2) Resolutions 2011-231 and 2011-232. Motion Carried.

RESULT: ADOPTED [UNANIMOUS]
MOVER: James Rogowski, Councilmember
SECONDER: Jeff Swiatek, Councilmember
AYES: Holtz, Jaworowicz, Swiatek, Rogowski, Markel
ABSENT: Richard Zydel, Stanley Kaznowski



25. RESOLUTION 2011-232

Hiring/Termination of Part-Time/Seasonal Employees

Sponsored By: Councilmember Swiatek, Supervisor Holtz

BE IT RESOLVED, that the following individuals be and hereby are hired as **SEASONAL EMPLOYEES**, not to exceed five (5) months in a calendar year, in the various departments listed and in compliance with Civil Service Laws and Regulations as well as the provisions of the Town's collective bargaining agreement between the Town of Cheektowaga and the Town of Cheektowaga Employees Association:

CENTRAL RECORDS MANAGEMENT Clerk \$8.25 effective 5/9/11
Ian D. Trapper, Cheektowaga, New York

FACILITIES DEPARTMENT (Parks Division) Laborer \$8.25/hour
Kyle Lackie, Cheektowaga, New York effective 6/20/11

FACILITIES DEPARTMENT (Parks Division) Laborer \$9.00/hour
David W. Cunningham, Cheektowaga, New York effective 4/19/11
Joseph Boccio, Depew, New York effective 5/1/11

FACILITIES DEPARTMENT (Parks Division) Laborer \$8.00/hour
Daniel F. Morgan, Cheektowaga, New York effective 5/9/11
Jonathan R. Heisler, Depew, New York effective 6/1/11
Matthew J. Pazderski, Cheektowaga, New York effective 6/20/11
Alex W. Kluck, Cheektowaga, New York effective 5/24/11
Eric J. Tomczak, Cheektowaga, New York effective 5/23/11
Brendan Hammer, Cheektowaga, New York effective 5/16/11
Drew A. Pijacki, Cheektowaga, New York effective 5/16/11
Michael Lawicki, Cheektowaga, New York effective 4/19/11

BE IT RESOLVED, that the following individuals be and hereby are hired as **PART-TIME EMPLOYEES** in the departments listed, not to exceed nineteen (19) hours on a weekly basis, in compliance with Civil Service Laws and Regulations as well as the provisions of the Town's collective bargaining agreement between the Town of Cheektowaga and the Town of Cheektowaga Employees Association:

JUSTICE COURT Clerk \$8.00/hour effective 4/19/11
William V. Matalonis, Cheektowaga, New York

SENIOR SERVICES Van Driver \$8.75/hour effective 4/18/11
Joseph Wodowski, Cheektowaga, New York

BE IT RESOLVED, that the following seasonal and/or part-time employees be and hereby are terminated as listed:

FACILITIES DEPARTMENT
Nicholas Herkey effective 10/9/10 (Laborer)
Timothy Dunkowski effective 3/2/11 (Laborer)

RESULT: **ADOPTED [UNANIMOUS]**
MOVER: Jeff Swiatek, Councilmember
SECONDER: Mary Holtz, Supervisor
AYES: Holtz, Jaworowicz, Swiatek, Rogowski, Markel
ABSENT: Richard Zydel, Stanley Kaznowski



26. RESOLUTION 2011-233

Appointment of Maintenance Worker (Non-Competitive/Temporary) Facilities Department (Building Maintenance Division)/Peter M. Kreavy, Jr.

Sponsored By: Councilmember Swiatek, Supervisor Holtz

WHEREAS, a temporary vacancy exists in the position of Maintenance Worker in the Facilities Department (Building Maintenance Division); AND

WHEREAS, Peter M. Kreavy, Jr. applied for said vacancy and meets the necessary qualifications for appointment; NOW, THEREFORE, BE IT

RESOLVED, that Peter M. Kreavy, Jr. of Cheektowaga, New York, be and hereby is appointed to the temporary position of Maintenance Worker in the Facilities Department (Building Maintenance Division), pursuant to the terms and conditions as set forth in the collective bargaining agreement between the Town of Cheektowaga and the Town of Cheektowaga Employees Association effective April 19, 2011.

RESULT:	ADOPTED [UNANIMOUS]
MOVER:	Jeff Swiatek, Councilmember
SECONDER:	Mary Holtz, Supervisor
AYES:	Holtz, Jaworowicz, Swiatek, Rogowski, Markel
ABSENT:	Richard Zydel, Stanley Kaznowski



27. RESOLUTION 2011-234

Travel Authorization Police Department/Lieutenant Thomas Gerace

Sponsored By: Councilmember Jaworowicz, Councilmember Swiatek

WHEREAS, the Advance Narcotics Leadership Seminar is being held May 3 through May 5, 2011 in Long Beach, New York; AND

WHEREAS, Lieutenant Thomas Gerace has requested authorization to attend said seminar; AND

WHEREAS, Police Chief David Zack has submitted a request for travel authorization along with the proper paperwork in a timely manner; AND

WHEREAS, the total cost to the Town shall not exceed \$1,114.31; AND

WHEREAS, these expenses have been budgeted by the Police Department; NOW, THEREFORE, BE IT

RESOLVED, that Lieutenant Thomas Gerace be and hereby is authorized to attend the Advance Narcotics Leadership Seminar being held May 3 through May 5, 2011 in Long Beach, New York.

RESULT:	ADOPTED [UNANIMOUS]
MOVER:	Patricia Jaworowicz, Councilmember
SECONDER:	Jeff Swiatek, Councilmember
AYES:	Holtz, Jaworowicz, Swiatek, Rogowski, Markel
ABSENT:	Richard Zydel, Stanley Kaznowski

IV. Suspension of Rules

Motion by Councilmember Rogowski; Seconded by Holtz to Waive the Rules to Include the following One (1) Resolution: 2011-235. Motion Carried
--



1. RESOLUTION 2011-235

Call for Public Hearing - Change to Previously Approved Rezoning Request - Portion of 2916 Union Road

Sponsored By: Councilmember Markel, Councilmember Rogowski

WHEREAS, Bernard Rusiniak has previously made application and requested the rezoning of a portion of 2916 Union Road from C- Retail Business to MS- Motor Services for the construction of a 2,500 square foot storage building, accessory to an existing motor vehicle repair facility, AND

WHEREAS, on June 21, 2009 The Town Board of the Town of Cheektowaga approved the rezoning request, AND

WHEREAS, the applicant now desires to utilize the newly constructed accessory building for motor vehicle repairs, rather than solely for accessory storage, NOW, THEREFORE BE IT

RESOLVED, that a Public Hearing be held regarding said change under the provisions of the Zoning Law on May 2, 2011 at 6:45 P.M., at the Cheektowaga Town Hall, 3301 Broadway at the corner of Union Road.

Notice of Public Hearing

NOTICE IS HEREBY GIVEN that a Public Hearing will be held by the Town Board of the Town of Cheektowaga, Erie County, New York at the Town Hall in the said Town of Cheektowaga, 3301 Broadway corner of Union Road on the 2nd day of May 2011 at 6:45 P.M., of said day for the purpose of considering the application of:

Bernard Rusiniak

for an amendment to a previously approved rezoning decision for a portion of 2916 Union Road from C- Retail Business to MS- Motor Services to use a recently constructed accessory building for motor vehicle repairs, rather than solely for accessory storage.

All parties in interest and citizens will be given an opportunity to be heard in regard to such proposed application.

BY ORDER OF THE TOWN BOARD, Town of Cheektowaga, NY

Alice Magierski, TOWN CLERK

LEGAL DESCRIPTION

ALL THAT TRACT OR PARCEL OF LAND situate in the Town of Cheektowaga, County of Erie, State of New York, being part of lot 15, township 11, range 7 of the Holland Land Company's Survey described as follows:

Beginning at a point at the north west corner of Bink Street and Union Road, thence in a northerly direction and along the western boundary of Union Road 216.38' to a point, thence in

a westerly direction 149.0' and along the Southerly line of Map Cover 527 to the point of beginning, thence, continuing in a westerly direction 145.0' to a point, thence in a southerly direction 75' to a point, thence in an easterly direction 145.0' to a point, thence in a northerly direction 75.0' to the point of beginning. Said area containing 10,875 square feet or 0.249 acres.

Attachments:

PLANNING BOARD MEETING MINUTES MARCH 2011 (PDF)

RESULT: ADOPTED [UNANIMOUS]
MOVER: Charles Markel, Councilmember
SECONDER: James Rogowski, Councilmember
AYES: Holtz, Jaworowicz, Swiatek, Rogowski, Markel
ABSENT: Richard Zydel, Stanley Kaznowski

V. Communications

A. Departmental Communications

1. Supervisor's Statement of Funds - February 2011
2. Town Environmental Advisory Committee - March 30, 2011
3. Town of Cheektowaga Emergency Services: Quarterly Report for January to March 2011

B. General Communications

1. County of Erie: Certificate and Notice of Highway Restriction and Closure: the Closure of Holtz Dr. from 4/19/11 to 4/22/11 Between Genesee & Aero Drive. Aero Drive Will be Closed from Youngs to Transit in Both Directions. No Traffic Will be Allowed, Local Traffic Only.
2. County of Erie: Certificate and Notice of Highway Restriction and Closure: Restriction: Holtz Dr. & Aero Dr. from 4/11/11 - to 5/31/11. Closure: Holtz Dr. from 4/12/11 to 4/15/11.
3. Summons & Complaint: Conrad Mikulec Vs. Town of Cheektowaga
4. Summons & Complaint: Kathryn Woods Vs. Town of Cheektowaga
5. Summons & Complaint: Melissa Woods Vs. Town of Cheektowaga
6. Notice of Claim: Michael Divens Vs. Town of Cheektowaga
7. Notice of Claim: James Harris Vs. Town of Cheektowaga
8. Notice of Claim: Steven Lauricella Vs. Town of Cheektowaga
9. Notice of Claim: Patrick McElroy Vs. Town of Cheektowaga

- 10. Notice of Claim: Geraldine A. Tropman Vs. Town of Cheektowaga
- 11. Notice of Claim: James Harris Vs. Town of Cheektowaga

VI. Comments

A. Supervisor's Comments

B. Councilmember's Comments

C. Public Comments

VII. Adjournment

Motion by Supervisor Holtz; Seconded by Councilmember Jaworowicz to adjourn the meeting in Memory of Robert Pietrzak, Member of the Cheektowaga Economic Development Corporation Board of Directors and a past member of the Cheektowaga Youth Board. Time: 7:02 PM

Alice Magierski, Town Clerk

RECEIVED
FEB 22 2011
Town Of Cheektowaga
Community Development Office

16055 Cutters Ct
Ft Myers FL 33908
Home-239-791-8290

Feb 16,2011

Dear Mr Gabryszak,

This letter wil serve as a formal confirmation to my offer to purchase the vacant lot at 36 Euclid ave Cheektowaga NY 14211, Which borders my property at 38 Euclid ave., For \$500.00 dollars.

I understand that in discussions with you that the Town will properly grade and sod the land before I take possession.

If this offer is acceptable to the Town please confirm by return letter to me at the address above.

Yours Sincerely,

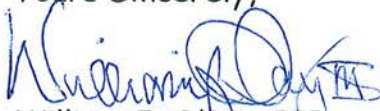
William J. O'Day III

Attachment: 36 Euclid - Purchase Offer (RES-2011-219 : Authorize Sale of 36 Euclid)

CHEEKTOWAGA PLANNING BOARD

MINUTES FROM MEETING OF MARCH 10TH, 2011

REGULAR MEETING WAS CALLED TO ORDER OF THE PLANNING BOARD OF THE TOWN OF CHEEKTOWAGA, ERIE COUNTY, NEW YORK AT THE TOWN HALL COUNCIL CHAMBERS IN SAID TOWN OF CHEEKTOWAGA MARCH 10TH, 2011 AT 7:00PM

PLEDGE LED BY MR. KUCEWICZ

Members: Joan Adams, *present*; Zigmund Kucewicz *present*; John Marriott, *present*; Joan Meyers, *present*; Ruth Casacci, *Present*.

Motion to accept and dispense with the reading of the February Meeting Minutes by xxxxx and 2nd by xxxxx. Motion carried unanimous.

OLD BUSINESS:

61 and 83 Anderson Road:

The applicant's representative presented a revised site plan showing both proposed hotel buildings relocated on the south side of the designated hotel area. Setbacks from the adjacent remaining building and Anderson Road were revised per recommendations by the EAC for adequate fire equipment and ladder access to the two proposed hotel buildings.

The applicant's representative asked for an opinion from the Planning Board as to whether they should continue on with this project. After a discussion on the information submitted to date, the Planning Board members were polled by the Chairman for an opinion on future acceptance of the project. The Planning Board felt that the applicant has been co-operative with the requests from the various town review boards, and that the two proposed hotels and the existing building renovations could be an asset and upgrade to the existing area. The Planning Board still prefers to defer a final recommendation until the results from the sanitary sewer capacity report is received from the Town Engineer and input from the public hearing.

This item has unresolved issues and remains tabled pending engineering approval, final SEQRA review and the outcome of the public hearing.

NOCO ENERGY CORP. 4590 Genesee Street: Convenience Store and Petroleum sales

The Planning Board has previously recommended approval of the site-plan at the February meeting.

At the February meeting the Planning Board requested an improved building design similar to the NOCO convenience store building located at Main Street and Youngs Road in Williamsville, NY, for this highly visible location. Architectural and landscape approval recommendations were tabled at the February Planning Board meeting pending the applicants submittal of an upgrade building design, more in keeping with the caliber of recent development around the airport and east on Genesee Street.

The applicant submitted revise drawing and 3-d renderings of a flat roof version all brick building design similar to the Main and Youngs NOCO store.

Motion to recommend Architectural and Landscape approval j. Meyers, 2nd j. Adams Motion carried, unanimous.

NEW BUSINESS

120 Losson Road
Wahl's' Candy, Building Addition
Site Plan, Architectural and Landscape Approval

The applicant had previously submitted preliminary site plan and elevation drawings for a 2,000 square foot warehouse addition on the west end of an existing sales warehouse building. At the preliminary meeting the applicant was requested to create a sloped roof in lieu of the proposed flat roof shown on the elevation drawings. Windows were also requested by the Board to break up the expanse of the large west wall. The applicant agreed to these requests, adding a sloped roof and four (4) windows to the west wall.

Motion to recommend Site Plan, Architectural and Landscape approval per drawings submitted at the March 2011 Planning Board meeting: 1st mar. Kucewicz, 2nd Ms. Casacci. Motion carried, unanimous.

2916 Union Road – Bernard Rusiniak, Jr. Change of Use Request

In September 2009 the Town Board on recommendation from the Planning Board, approved a rezoning request for a 75-foot X 75-foot section at the northwest corner of his site from C-Retail Business to MS-Motor Services. This was to allow for construction of a 2,500 square separate garage storage building accessory to his existing motor vehicle service station. At the time of the request the applicant stated that the garage was for the sole purpose of storing parts required for his existing automotive service business.

The applicant proposes to use the garage for his own automotive repair business or possibly lease it to another automotive related service operation.

The Planning Board discussed this request with the applicant, noting that because of the inherent nuisances, the Town has a policy of carefully controlling the expansion and location of motor service uses. The garage in question is sited directly behind the adjacent residence on Bink Street. Because of the change in use, the Town Board will have to schedule a public hearing.

In order to move this request to the Public Hearing the Planning Board is required to make a recommendation. Because of the potential impacts from this request and how they could be mitigated, the Planning Board elected to make a recommendation to deny this request, which could be changed based on further evaluation and the outcome of the public hearing. The applicant understands the decision and is in agreement.

Motion to recommend denial of the request for purposes of moving it to the Public Hearing: Motion: Mr. Marriott, 2nd Mr. Kucewicz. Motion carried, unanimous.

Motion made and seconded to adjourn.

Respectfully submitted,

Joan C. Meyers, Secretary
Cheektowaga Planning Board

Jm/jm



Town of Cheektowaga

Regular Meeting

~ Minutes ~

3301 Broadway
Cheektowaga, NY 14227
<http://www.town.cheektowaga.ny.us>

Alice Magierski
716-686-3400

Monday, May 2, 2011

6:45 PM

Council Chambers

I. Call to Order

6:45 PM Meeting called to order on May 2, 2011 at Council Chambers, 3301 Broadway St, Cheektowaga, NY.

Attendee Name	Organization	Title	Status	Arrived
Mary Holtz	Town of Cheektowaga	Supervisor	Present	
Patricia Jaworowicz	Town of Cheektowaga	Councilmember	Present	
Jeff Swiatek	Town of Cheektowaga	Councilmember	Present	
James Rogowski	Town of Cheektowaga	Councilmember	Present	
Richard Zydel	Town of Cheektowaga	Councilmember	Present	
Charles Markel	Town of Cheektowaga	Councilmember	Present	
Stanley Kaznowski	Town of Cheektowaga	Councilmember	Present	

2. Additional Attendees

Ellen Fischer, Executive Director - Youth Board
Brian Krause, Director of Finance and Administration
John Marriott, Planning Board Chairman
William Pugh, Town Engineer
Anthony Romano, Coordinator of Employee Relations
Kevin Schenk, Town Attorney

II. Public Comment Period

III. Public Hearings

1. Install Curbing Along North Meadowbrook Parkway

This being the time and place advertised for a Public Hearing, the Supervisor directed the Town Clerk to present that such notice has been duly published and posted; upon the order of the Supervisor such proof was duly filed.

The Supervisor announced that the Town Board would hear all persons interested in the subject of the hearing. Comments were heard, after which the Supervisor declared the hearing closed, decision was reserved.

RESULT: CLOSED [UNANIMOUS]
MOVER: James Rogowski, Councilmember
SECONDER: Richard Zydel, Councilmember
AYES: Holtz, Jaworowicz, Swiatek, Rogowski, Zydel, Markel, Kaznowski

2. Change to Previously Approved Rezoning Request - Portion of 2916 Union Road

This being the time and place advertised for a Public Hearing, the Supervisor directed the Town Clerk to present that such notice has been duly published and posted; upon the order of the Supervisor such proof was duly filed.

The Supervisor announced that the Town Board would hear all persons interested in the subject of the hearing. Comments were heard, after which the Supervisor declared the hearing closed, decision was reserved.

RESULT: CLOSED [UNANIMOUS]
MOVER: James Rogowski, Councilmember
SECONDER: Charles Markel, Councilmember
AYES: Holtz, Jaworowicz, Swiatek, Rogowski, Zydel, Markel, Kaznowski

IV. Resolutions



1. RESOLUTION 2011-236

Transfer of Funds - 2010

Sponsored By: Supervisor Holtz, Councilmember Swiatek

BE IT RESOLVED, that the following transfer is hereby approved and made a part hereof;

2010

GENERAL FUND

FROM:	100.9501.9211	Bond Interest	\$ 369,100.00
	100.9010.8101	Employees Retirement	243,400.00

TO:	100.9950.8729	Transfer to Capital	\$ 369,100.00
	100.9010.8975	Retirement Buyout	243,400.00

HIGHWAY FUND

FROM:	300.5148.2300	Services from Other Gov't	\$ 30,000.00
-------	---------------	---------------------------	--------------

TO:	300.9950.8000	Transfer to Capital	\$ 30,000.00
-----	---------------	---------------------	--------------

SPECIAL DISTRICTS FUND

FROM:	255.8125.9201	Bond Interest	\$ 91,000.00
	255.8125.9101	Bond Principle	416,338.00

TO:	255.8125.9990	Transfer to Capital	\$ 507,338.00
-----	---------------	---------------------	---------------

PART TOWN FUND

FROM:	800.9010.8101	Retirement Buyout	\$ 27,564.00
	800.1910.4711	Contingency	28,719.00

TO:	800.9010.8975	Retirement Buyout	\$ 54,455.00
	800.9010.8121	Social Security	1,828.00

RESULT:	ADOPTED [UNANIMOUS]
MOVER:	Mary Holtz, Supervisor
SECONDER:	Jeff Swiatek, Councilmember
AYES:	Holtz, Jaworowicz, Swiatek, Rogowski, Zydel, Markel, Kaznowski



2. RESOLUTION 2011-237

Transfer of Funds - 2011

Sponsored By: Supervisor Holtz, Councilmember Swiatek

BE IT RESOLVED, that the following transfer is hereby approved and made a part hereof;

2011

GENERAL FUND

FROM:	100.3120.3820	State Aid Police	\$ 76,391.79
	100.1415.3500	Archive Grant	17,923.50
	100.1415.3500	Archive Grant	2,930.00
TO:	100.3120.2206	LEBG	\$ 5,567.69
	100.3120.2207	Jag Grant	70,824.10
	100.1415.4001	Contractual Services	17,923.50
	100.1415.4001	Contractual Services	2,930.00

RESULT: **ADOPTED [UNANIMOUS]**

MOVER: Mary Holtz, Supervisor

SECONDER: Jeff Swiatek, Councilmember

AYES: Holtz, Jaworowicz, Swiatek, Rogowski, Zydel, Markel, Kaznowski



3. RESOLUTION 2011-238

Warrant

Sponsored By: Supervisor Holtz, Councilmember Swiatek

BE IT RESOLVED, that the following Vouchers & Warrants submitted to the Town of Cheektowaga prior to April 29, 2011 are hereby approved and made a part hereof;

GENERAL FUND	\$ 3,369,908.02
RISK RETENTION FUND	94,643.06
SPECIAL DISTRICTS FUND	1,008,001.52
HIGHWAY FUND	1,082,464.61
CAPITAL FUND	368,869.14
TRUST & AGENCY FUND	192,467.81
HUD CDBG FUND	5,528.80
PART TOWN FUND	129,257.67
NYS AFFORDABLE HOUSING	5,226.00
	<u>\$ 6,256,366.63</u>

RESULT: **ADOPTED [UNANIMOUS]**

MOVER: Mary Holtz, Supervisor

SECONDER: Jeff Swiatek, Councilmember

AYES: Holtz, Jaworowicz, Swiatek, Rogowski, Zydel, Markel, Kaznowski



4. RESOLUTION 2011-239

Approval of Improvement of North Meadowbrook Parkway by the Construction and Installation of Curbing

Sponsored By: Supervisor Holtz, Councilmember Swiatek

WHEREAS, a written petition dated March 26, 2011 was heretofore presented and filed with the Town Board of the Town of Cheektowaga pursuant to Section 200 of the Town Law of the State of New York, praying for the improvement of the following portion of North Meadowbrook Parkway (the area benefited by said improvement):

ALL THAT TRACT OR PARCEL OF LAND, situate in the Town of Cheektowaga, County of Erie and State of New York, being part of Lot No. 147, Township 10, Range 7 of the Buffalo Creek Reservation, generally described as follows:

North Meadowbrook Parkway, both sides, from the north side of Dingens Street to the north side of Bismarck Street.

by the construction and installation of curbing and other necessary related improvements in connection therewith along the entire length on both sides of the portion of North Meadowbrook Parkway described above, at a maximum cost of \$47,120.00, and

WHEREAS, a pavement has been heretofore constructed along said portion of North Meadowbrook Parkway described in the petition, said petition was signed by the owners of real estate fronting or abutting upon either side of the portion of North Meadowbrook Parkway to be improved, to the extent of at least one-half of the entire frontage or bounds on both sides of the portion of said street to be improved, and the resident owners owing not less than one-half of the frontage owned by resident owners residing in or along the portion of said street covered or represented by said petition, was duly acknowledged or proved by all signers thereof in the same manner as a deed to be recorded, and provided that the expense of the construction of said improvement shall be borne by local assessment upon the several parcels of land especially benefited thereby all as stated in said petition and as more fully provided by applicable law, and

WHEREAS, the Town Board thereafter adopted an Order reciting in general terms the filing of said petition, the improvements proposed, the maximum amount proposed to be expended for the improvement and the area benefited as stated in the petition, and stating that the Town Board would meet to hear all persons interested in the improvement of said portion of North Meadowbrook Parkway described in the petition on May 2, 2011 at 6:45 P.M. at the Town Hall, and

WHEREAS, copies of said Order, certified by the Town Clerk, were duly published and posted pursuant to the provisions of Article 12 of the Town Law, and

WHEREAS, such public hearing was duly held by the Town Board on the 2nd day of May, 2011 at the Town Hall in said Town at 6:54 P.M. and discussion on the matter having been had and all persons desiring to be heard having been heard, including those in favor of and those in opposition to the improvement of said portion of North Meadowbrook Parkway,

NOW, THEREFORE, BE IT

RESOLVED BY THE TOWN BOARD OF THE TOWN OF CHEEKTOWAGA, IN THE COUNTY OF ERIE, NEW YORK, AS FOLLOWS:

Section 1. It is hereby determined that

- (a) the notice of public hearing, hereinabove referred to in the recitals thereof, was published and posted as required by law and is otherwise sufficient;
- (b) it is in the public interest to so improve said portion of North Meadowbrook Parkway, in the Town, as hereinabove referred to in the recitals hereof;
- (c) all the real property fronting or abutting upon both sides of said portion of North Meadowbrook Parkway to be improved as described in the petition, being the area benefited by the improvement, is benefited thereby.

Section 2. Curbs and other necessary improvements shall be constructed and installed along both sides of said portion of North Meadowbrook Parkway described in the petition, as hereinabove referred to in the recitals hereof, in accordance with the specifications required by the Town, now in effect, at a cost not to exceed \$47,120.00, the maximum amount proposed to be expended thereof as stated in the petition.

Section 3. The Town Engineer shall prepare definite plans and specifications and make a careful estimate of the expense of said improvement, and with the assistance of the Town Attorney, prepare a contract for the execution of the work, which plans and specifications, estimate and proposed contract shall be presented to the Town Board as soon as possible.

Section 4. It is hereby determined that the expense of said improvement shall be paid initially out of the general fund of the Town of Cheektowaga and paid back through the levy and collection of special assessments from the several lots and parcels within the Town which the Town Board shall determine to be especially benefited by said improvement, so much upon and from each as shall be in just proportion to the amount of benefit which the improvement shall confer upon the same, to pay back the principal of and interest on said funds over a period of 5-10 years.

Section 5. The Town Clerk is hereby directed to records a certified copy of this Resolution Approving the Improvement of North Meadowbrook Parkway by the Construction and Installation of Curbing in the Office of the Clerk of the County of Erie within ten (10) days after the adoption thereof.

Section 6. This resolution shall take effect immediately.

RESULT:	ADOPTED [UNANIMOUS]
MOVER:	Mary Holtz, Supervisor
SECONDER:	Jeff Swiatek, Councilmember
AYES:	Holtz, Jaworowicz, Swiatek, Rogowski, Zydel, Markel, Kaznowski



5. RESOLUTION 2011-240

Adopt Policy Concerning Disposal of Scrap Metal

Sponsored By: Supervisor Holtz, Councilmember Swiatek

WHEREAS, the Town of Cheektowaga regularly collects scrap metal which is placed at the curb by Town residents for disposal by the Town, and

WHEREAS, other Town departments, on occasion, have scrap metal which is surplus to the needs of the Town and needs to be disposed of, and

WHEREAS, this Board desires to establish a policy for the storage and disposition of said scrap metal, including the deposit of moneys collected from the sale of said scrap metal,
NOW

RESOLVED, that, effective immediately, this Town Board hereby adopts the following policy relating to the collection, storage and disposition of scrap metal:

COLLECTION, STORAGE AND DISPOSITION OF SCRAP METAL IN THE POSSESSION OF TOWN DEPARTMENTS

1. Any scrap metal which shall come into the possession of the Town Highway Department shall be retained by the Town Superintendent of Highways or the Deputy Town Superintendent of Highways to be secured and disposed of according to the guidelines in this policy.
2. Any scrap metal which shall comes into the possession of the Town Sewer Maintenance Department, Wastewater Pump Station and Engineering Department shall be retained by the Town Engineer or Assistant Town Engineer to be secured and disposed of according to the guidelines in this policy.
3. Any other Town department which comes into possession of scrap metal that is no longer needed for said department's use shall forward said scrap metal to the Sanitation Department for sale.
4. No scrap metal shall be used for the personal use of any Town employee, nor shall any Town Employee remove any scrap metal from Town premises.
5. Scrap metal shall be retained in a secured/locked fenced-in area in the vicinity of the Highway Department, Engineering Department (including Sewer Maintenance Department and Wastewater Pump Station) or Sanitation Department building. Keys for the lock shall be under the control of the General Foreman/Department Head or Assistant Department Head of the respective Department and he/she shall be responsible to safeguard and monitor the area to ensure that scrap metal is not removed from said area without his/her permission when it is sold to a scrap metal dealer
6. The General Foreman/Department Head/Assistant Department Head of the respective Department shall be empowered to sell all scrap metal contained in the designated secured fenced-in area. He/she shall canvas local scrap metal dealers, attempt to obtain three (3) quotes and solicit the highest value for all scrap metal. He/she shall maintain full records of all transactions.
7. Payments to the Town of Cheektowaga for scrap metal shall be in the form of checks; no cash shall be accepted
8. The General Foreman/Department Head/Assistant Department Head of the respective

Department shall forward all checks from the sale of scrap metal to the Town Accounting Department for deposit into the appropriate account(s).

9. Department heads shall be responsible for monitoring their employees to ensure this scrap metal policy is followed.

RESULT:	ADOPTED [UNANIMOUS]
MOVER:	Mary Holtz, Supervisor
SECONDER:	Jeff Swiatek, Councilmember
AYES:	Holtz, Jaworowicz, Swiatek, Rogowski, Zydel, Markel, Kaznowski



6. RESOLUTION 2011-241

Award of Bid for Asbestos Survey - 89 Gardenvale Drive

Sponsored By: Councilmember Markel, Councilmember Kaznowski

WHEREAS, pursuant to the Unsafe Buildings Law of the Town of Cheektowaga, this Town Board can require that unsafe buildings be either repaired or demolished, and

WHEREAS, the building located at 89 Gardenvale Drive has experienced extensive deterioration and damage, and Nussbaumer & Clarke, Inc. determined that said building is unsafe and recommended that such building be demolished and removed, and

WHEREAS, by resolution dated January 18, 2011 (#2011-44) this Town Board ordered that the building located at 89 Gardenvale Drive either repaired or demolished, and directed that the owners or others responsible for the building commence said repair or demolition work within 30 days, and

WHEREAS, more than 30 days have expired and no work has been commenced with respect to 89 Gardenvale Drive, and

WHEREAS, pursuant to the Unsafe Buildings Law, this Town Board can provide for the demolition of an unsafe building and assess the cost of same against the property, and

WHEREAS, prior to the demolition of 89 Gardenvale Drive, the Town needs to retain a firm to perform an asbestos survey and asbestos abatement plan for same, and

WHEREAS, this Town Board issued a Notice to Bidders to various asbestos abatement firms and, based on proposals submitted, the Town Attorney has recommended that this Town Board retain 56 Services, Inc. at the total flat fee of \$1,400.00 to perform said asbestos survey, specifications and project monitoring work with respect to 89 Gardenvale Drive, NOW, THEREFORE, BE IT

RESOLVED, that this Town Board hereby retains 56 Services, Inc., P.O. Box 561, Buffalo, New York 14213 to perform the necessary asbestos survey and abatement work (if necessary) for 89 Gardenvale Drive at the cost listed above, and BE IT FURTHER

RESOLVED, that the Supervisor be and hereby is directed to execute an agreement with 56 Services, Inc. for said services, and BE IT FURTHER

RESOLVED, that moneys for said services shall be appropriated from budget line item number 0800-800-0440.

RESULT:	ADOPTED [UNANIMOUS]
MOVER:	Charles Markel, Councilmember
SECONDER:	Stanley Kaznowski, Councilmember
AYES:	Holtz, Jaworowicz, Swiatek, Rogowski, Zydel, Markel, Kaznowski



7. RESOLUTION 2011-242

Award of Bid - Installation of Solar Power Systems on Various Town Buildings

Sponsored By: Supervisor Holtz, Councilmember Swiatek

WHEREAS, a Notice to Bidders was published for the receipt of bids for the Installation of Solar Power Systems on Various Town of Cheektowaga Buildings, which bids were duly received and opened on April 13, 2011 at 11:00 am by the Town Clerk, AND

WHEREAS, said bids were referred to the Town Engineer and Project Consulting Engineer, Nussbaumer & Clarke, Inc., for analysis, tabulation and report as detailed in a letter from the Town Engineer dated April 27, 2011, AND

WHEREAS, said letter recommends that the contract for the Installation of Solar Power Systems on Various Town Buildings be awarded to O'Connell Electric Company, Inc., 830 Phillips Road, Victor, New York 14564 for their submission of the lowest bid price of \$937,496.00 meeting the requirements of the contract specifications, AND, BE IT FURTHER

RESOLVED, that the Supervisor, on behalf of this Town Board, be and hereby is authorized and directed to execute any and all agreements for the aforementioned project, including NYSERDA Solar P.V. Incentive Applications, AND, BE IT FURTHER

RESOLVED, that funding for the subject project shall be chargeable to Account No. 500-1440-2065-5021.

RESULT:	ADOPTED [UNANIMOUS]
MOVER:	Mary Holtz, Supervisor
SECONDER:	Jeff Swiatek, Councilmember
AYES:	Holtz, Jaworowicz, Swiatek, Rogowski, Zydel, Markel, Kaznowski



8. RESOLUTION 2011-243

Award of Bid - 2012 Truck with 2011 High Velocity Sewer Cleaner

Sponsored By: Councilmember Kaznowski, Councilmember Zydel

WHEREAS, bids were duly received and opened at a public bid opening on April 20, 2011 for the purchase of one (1) new and unused 2012 truck with 2011 high velocity sewer cleaner for the Sewer Maintenance Department, AND

WHEREAS, said bids were referred to the Town Engineer for analysis, tabulation and report, AND

WHEREAS, the Town will sell the 1999 high velocity sewer cleaner thru Auctions International, Inc., NOW, THEREFORE, BE IT

RESOLVED, that the contract for the purchase of one (1) new and unused 2012 truck with 2011 high velocity sewer cleaner be and hereby is awarded to:

Joe Johnson Equipment (USA) Inc.
62 LaGrange Avenue
Rochester, New York 14613

for their bid in the amount of \$154,215.00, said bid being the lowest meeting the requirements of the specifications, AND, BE IT FURTHER

RESOLVED, that funds have been budgeted for the purchase of one (1) 2012 truck with 2011 high velocity sewer cleaner in Account #255-8125-2550.

RESULT:	ADOPTED [UNANIMOUS]
MOVER:	Stanley Kaznowski, Councilmember
SECONDER:	Richard Zydel, Councilmember
AYES:	Holtz, Jaworowicz, Swiatek, Rogowski, Zydel, Markel, Kaznowski



9. RESOLUTION 2011-244

Call for Public Hearing - Rezoning Request 83 Anderson Road and Part of 61 Anderson Road

Sponsored By: Councilmember Markel, Councilmember Rogowski

WHEREAS, Jonathan E. Bennett Architecture, P.C. on behalf of the land owners, The Kabir Group, LLC & Lee Dee & Sons, LLC has made application and requested the rezoning of 83 Anderson Road and Part of 61 Anderson Road from M2 - General Manufacturing to CM-General Commercial for the construction of a six story hotel and a four story hotel, NOW, THEREFORE BE IT

RESOLVED, that a Public Hearing be held regarding said request under the provisions of the Zoning Law on May 16th, 2011 at 6:45 P.M., at the Cheektowaga Town Hall, 3301 Broadway at the corner of Union Road.

Notice of Public Hearing

NOTICE IS HEREBY GIVEN that a Public Hearing will be held by the Town Board of the Town of Cheektowaga, Erie County, New York at the Town Hall in the said Town of Cheektowaga, 3301 Broadway corner of Union Road on the 16th day of May, 2011 at 6:45 o'clock P.M., of said day for the purpose of considering the application of:

Jonathan E. Bennett Architecture, P.C.

for the rezoning of 83 Anderson Road and part of 61 Anderson Road from M2 - General Manufacturing to CM- General Commercial for the construction of a six story hotel and a four story hotel.

All parties in interest and citizens will be given an opportunity to be heard in regard to such proposed application.

BY ORDER OF THE TOWN BOARD, Town of Cheektowaga, NY

Alice Magierski, TOWN CLERK

LEGAL DESCRIPTION

ALL THAT TRACT OR PARCEL OF LAND, situate in the Town of Cheektowaga, County of Erie, and State of New York, being part of Lot 24, Township 11, Range 7 of the Holland Land Company's Survey, being more particularly described as follows:

BEGINNING a point in the centerline of Anderson Road (60' wide) distant 730.75 feet northerly from its intersection with the centerline of Dale Road, formerly known as Walden Avenue (66' wide), said centerline also being the centerline of a private road (100' wide) extending from Old Walden Avenue; thence northerly along the said centerline of Anderson Road, a distance of 68.25 feet to a point; thence easterly at an interior angle of 90° 00' 00", a distance of 122.00 feet to a point; thence southerly at an interior angle of 90° 00' 00", a distance of 68.25 feet to a point;

thence westerly at an interior angle of 90° 00' 00", a distance of 122.00 feet to the point or place of beginning, containing 8,326 +/-square feet or 0.19 acre of land more or less.

ALSO, ALL THAT TRACT OR PARCEL OF LAND, situate in the Town of Cheektowaga, County of Erie, and State of New York, being part of Lot 24, Township 11, Range 7 of the Holland Land Company's Survey, being more particularly described as follows:

BEGINNING a point in the centerline of Anderson Road (60' wide) distant 799.00 feet northerly from its intersection with the centerline of Dale Road, formerly known as Walden Avenue (66' wide), said centerline also being the centerline of a private road (100' wide) extending from Old Walden Avenue; thence northerly along the said centerline of Anderson Road, a distance of 150.00 feet to a point; thence easterly at an interior angle of 90° 00' 00", a distance of 412.46 feet to a point; thence southerly at an interior angle of 90° 00' 00", a distance of 150.00 feet to a point; thence westerly at an interior angle of 90° 00' 00", a distance of 412.46 feet to the point or place of beginning, containing 61,869 +/-square feet or 1.42 acres of land more or less.

ALSO, ALL THAT TRACT OR PARCEL OF LAND, situate in the Town of Cheektowaga, County of Erie, and State of New York, being part of Lot 24, Township 11, Range 7 of the Holland Land Company's Survey, being more particularly described as follows:

COMMENCING a point in the centerline of Anderson Road (60' wide) distant 799.00 feet northerly from its intersection with the centerline of Dale Road, formerly known as Walden Avenue (66' wide), said centerline also being the centerline of a private road (100' wide) extending from Old Walden Avenue; thence easterly at an angle of 90° 00' 00" to the said centerline of Anderson Road, a distance of 412.46 feet to the POINT OF BEGINNING; thence northerly at an interior angle of 90° 00' 00", a distance of 150.00 feet to a point; thence easterly at an interior angle of 90° 00' 00", a distance of 216.99 feet to a point; thence southerly at an interior angle of 90° 00' 00", a distance of 150.00 feet to a point; thence westerly at an interior angle of 90° 00' 00", a distance of 216.99 feet to the point or place of beginning, containing 32,548 +/-square feet or 0.75 acre of land more or less.

RESULT:	ADOPTED [UNANIMOUS]
MOVER:	Charles Markel, Councilmember
SECONDER:	James Rogowski, Councilmember
AYES:	Holtz, Jaworowicz, Swiatek, Rogowski, Zydel, Markel, Kaznowski



10. RESOLUTION 2011-245

Designate EMS Board

Sponsored By: Supervisor Holtz, Councilmember Jaworowicz

WHEREAS, in order to provide for the provisions of emergency medical services on a uniform basis, this Town Board, on May 7, 1984, adopted an Ambulance Services Ordinance, AND

WHEREAS, said Ordinance provides for the establishment of an Emergency Medical Services Board ("EMS Board") which will act as agent of the Town in the implementation of the Ordinance, AND

WHEREAS, the composition of the EMS Board is set forth in Section 52-7 of the Code of the Town of Cheektowaga , AND

WHEREAS, the terms of the present individuals who were appointed to the EMS Board expired, NOW, THEREFORE, BE IT

RESOLVED, that the following individuals shall be designated to serve as members of the EMS Board for 2011 for a term of one year:

REPRESENTING	DESIGNATE	ALTERNATE
Bellevue	Jamie Casucci	Ed Kutas,
Cleveland Hill	Arnold Nelson	
Doyle	Richard Ralecki	Charles Schnurstein & Mark Jedd
Forks	Paul Hockwater, Jr.	EMS Officers
Hy-View	Robert Schmitt	Roman Gawronski
Pine Hill	Brandon Ashraf	David Caprio
Sloan	Barry Ping	
South Line	Ed Fialkowski	Kyle Tobolski/Jay Tolsma
U-Crest	Ronald Wanat	Michael Graczyk
Walden	Michael Divens	Kris Tower
St. Joe's Hospital Chief of Police	Dr. Frank Lee	
Dispatch	Captain John Glascott	
Town Board	Paul Hockwater Jr. Supervisor Holtz	
EX-OFFICIO MEMBERS (non-voting)		
Rural/Metro	Richard Bartel	
County EMS	John Adolph	

and, BE IT FURTHER

RESOLVED, that Robert Schmitt be appointed to serve as Chairman of the EMS Board

RESULT: ADOPTED [UNANIMOUS]

MOVER: Mary Holtz, Supervisor
SECONDER: Patricia Jaworowicz, Councilmember
AYES: Holtz, Jaworowicz, Swiatek, Rogowski, Zydel, Markel, Kaznowski



11. RESOLUTION 2011-246

Special Event - Cleveland Hill Little League

Sponsored By: Councilmember Rogowski, Councilmember Zydel

WHEREAS, by resolution dated May 1, 1995, this Town Board adopted a Special Events policy, which requires anyone wishing to hold a special event in the Town to file an application and supporting documentation, fees, etc. to the Town Clerk prior to the special event, and

WHEREAS, Cleve Hill Baseball, Inc. has made application to hold a parade on Saturday, May 21, 2011, beginning at 10:00 A.M. as follows:

Parade will assemble at the Cleveland Hill School parking lot, exit onto Gilmore Road to Maplevue Road; and proceed to Rost, Harlem, Huth, Woodridge, Maplevue and Commodore; AND

WHEREAS, this Board has reviewed the aforementioned application, which application has been approved by the Cheektowaga Police Department, the Facilities Department, and the Department of Youth and Recreation, and has no objection to same, and

WHEREAS, due to the nature of the event, this Town Board hereby waives the following requirements: Submittal of plan for sanitary facilities;

- 1) Submittal of site plan;
- 2) Requirement that application be made at least 60 days prior to the date of the special event;
- 3) Submittal of Security Plan;
- 4) Submittal of Fire Prevention/Emergency Services Plan.

NOW, THEREFORE, BE IT

RESOLVED, that this Town Board hereby approves the aforementioned application of Cleve Hill Baseball, Inc. for the aforementioned parade to be held on Saturday, May 21, 2011, and BE IT FURTHER

RESOLVED, that the Chief of Police be and hereby is directed to provide traffic safety and escort services for such parade and to ensure compliance with Section 1660 (a)(6) of the Vehicle and Traffic Law.

RESULT:	ADOPTED [UNANIMOUS]
MOVER:	James Rogowski, Councilmember
SECONDER:	Richard Zydel, Councilmember
AYES:	Holtz, Jaworowicz, Swiatek, Rogowski, Zydel, Markel, Kaznowski



12. RESOLUTION 2011-247

Special Event - Polish Festival

Sponsored By: Supervisor Holtz, Councilmember Rogowski

WHEREAS, by resolution dated May 1, 1995, this Town Board adopted a Special Events policy, which requires anyone wishing to hold a special event in the Town to file an application and supporting documentation, fees, etc. to the Town Clerk prior to the special event, and

WHEREAS, the Polish-American Arts Festival Committee has made application to hold its annual Polish-American Cultural Festival in Cheektowaga Town Park from July 15th to July 17th, 2011; and

WHEREAS, this Board has reviewed the aforementioned application, which application has been approved by the Facilities Department, the Department of Recreation & Youth Services, Police Department, Highway Department and the Building Department, and has no objection to same, and

WHEREAS, due to the nature of the event, this Town Board hereby waives the following requirements:

1. Submittal of plan for sanitary facilities;
2. Submittal of site plan;
3. Requirement that application be made at least 60 days prior to the date of the special event;
4. Submittal of Security Plan;
5. Submittal of Fire Prevention/Emergency Services Plan;

NOW, THEREFORE, BE IT

RESOLVED, that this Town Board hereby approves the aforementioned application of the Polish-American Arts Festival Committee for the aforementioned Polish-American Arts Festival to be held in Cheektowaga Town Park from July 15th to July 17th, 2011.

RESULT:	ADOPTED [UNANIMOUS]
MOVER:	Mary Holtz, Supervisor
SECONDER:	James Rogowski, Councilmember
AYES:	Holtz, Jaworowicz, Swiatek, Rogowski, Zydel, Markel, Kaznowski



13. RESOLUTION 2011-248

Request that Erie County Redistricting Plan Place Town of Cheektowaga into One District

Sponsored By: Rogowski, Holtz, Jaworowicz, Swiatek, Zydel, Markel, Kaznowski

WHEREAS, in November of 2010, the voters of Erie County approved Proposition 1 on the Erie County ballot to downsize the size of the Erie County Legislature from fifteen (15) to eleven (11) Members, and

WHEREAS, the Erie County Advisory Committee on Reapportionment was established to design new legislative districts based on census shifts and the downsizing of the Legislature, and

WHEREAS, the Erie County Advisory Committee on Reapportionment is currently working on recommendations for a new eleven (11) member reapportionment plan for the forthcoming downsized Erie County Legislature; and

WHEREAS, it has long been the public policy of the State of New York, in matters of drawing district lines for legislative districts at the state and county levels, to maintain the integrity of the municipal boundaries of towns whenever possible; and

WHEREAS, under the provisions of New York State Municipal Home Rule Law, Section 10 (1)(ii)a.(13), in drawing such districts, no town whose population is less than 110 % of the population of an average Legislative district (i.e. 83,549 in Erie County this year) should be divided between different county legislative districts; and

WHEREAS, the Town of Cheektowaga with a 2010 census population of 88,226 (105.6% above the average size of a legislative district in Erie County), does not exceed the threshold number of 91,904 (being 110% of an average size legislative district); and

WHEREAS, the citizens and taxpayers of the Town of Cheektowaga will be best served if the public policy of maintaining the integrity of municipal boundaries is preserved in drawing the lines for the 2011 Erie Legislative district plan; and

WHEREAS, the residents of the Town of Cheektowaga will be best served and represented, knowing they have a single representative in the Erie County Legislature, who can respond to their inquiries and best represent them in county issues of local importance; and

WHEREAS, the Town Board of the Town of Cheektowaga will also be better able to communicate with the Erie County Legislature on matters of local concern to Town of Cheektowaga with a single legislator representing the entire Town of Cheektowaga; and

WHEREAS, the Town of Cheektowaga has previously been the victim of political gerrymandering by having the Town divided between county legislative districts in the past;

WHEREAS, the Town of Cheektowaga is currently a clear example of political gerrymandering under the county legislature districting plan for the past eight (8) years; our population justified division between the two (2) legislative districts, but it was and has been divided among the five (5) districts; and

WHEREAS, the Town of Cheektowaga is currently the second largest township in the County of Erie, and has rightfully one eleventh of the population of Erie County; NOW, THEREFORE, BE IT

RESOLVED, that the Town Board of the Town of Cheektowaga does hereby request that the Erie County Advisory Committee on Reapportionment and the Erie County Legislature respect and adhere to the public policy of New York State in not dividing towns within Erie County with a population of no more than 91,904, being 110% of the size of an average county legislative district; and BE IT FURTHER

RESOLVED, that the Town Board of the Town of Cheektowaga does hereby request that any such final redistricting plan adhere to such policy and not divide the Town of Cheektowaga between or amongst different legislative districts, but rather place the Town of Cheektowaga wholly within the boundaries of a single county legislative district; and BE IT FURTHER

RESOLVED, that the Town Board of the Town of Cheektowaga does hereby request that any such final redistricting plan adhere to such policy and also not divide the Town of Cheektowaga (including the Village of Sloan), between or amongst different legislative districts but maintain the Town of Cheektowaga, together with the Village of Sloan, wholly within the boundaries of a single county legislative district; and BE IT FURTHER

RESOLVED, that the Town Board does hereby extend an invitation to the Erie County Advisory Committee on Reapportionment to conduct a public hearing to hear the opinions of the residents of the Town of Cheektowaga; and BE IT FURTHER

RESOLVED, that a local hearing in the Town of Cheektowaga can be conducted at the Town Hall (3301 Broadway Cheektowaga, NY 14227) ,and this Board will cooperate by assisting in making arrangements to conduct such a public hearing at the Town Hall; and BE IT FURTHER

RESOLVED, that the Town Clerk be and hereby is directed to immediately forward a copy of this resolution to the Erie County Advisory Commission on Reapportionment and to each of the Erie County Legislators for consideration in relation to the upcoming deliberations on the Legislative Reapportionment Plan for 2011.

RESULT:	ADOPTED [UNANIMOUS]
MOVER:	James Rogowski, Councilmember
SECONDER:	Mary Holtz, Supervisor
AYES:	Holtz, Jaworowicz, Swiatek, Rogowski, Zydel, Markel, Kaznowski



14. RESOLUTION 2011-249

Subrecipient Agreement for HOME Program

Sponsored By: Councilmember Markel, Supervisor Holtz

WHEREAS, the Towns of Cheektowaga, Amherst and Tonawanda have formed a Consortium for the purpose of applying for Entitlement HOME funds from the United States Department of Housing and Urban Development under the HOME Investment Partnership Act, and

WHEREAS, the Town of Amherst has been designated as the lead community on behalf of the Amherst-Cheektowaga-Tonawanda HOME Consortium,

WHEREAS, as lead community, the Town of Amherst, is responsible for the distribution of funds to the subrecipient Consortium communities which manage projects utilizing said HOME funds, and

WHEREAS, the Department of Housing and Urban Development requires the lead community and recipients of HOME funds to execute subrecipient agreements, NOW, THEREFORE, BE IT

RESOLVED, that the Supervisor be and hereby is authorized to execute a Subrecipient Agreement with the Town of Amherst, as lead community for the Amherst-Cheektowaga-Tonawanda HOME Consortium, subject to review and approval by the Town Attorney and the Director of Community Development, for the receipt of HOME Investment Partnership Act funds for the 2011 program year.

RESULT:	ADOPTED [UNANIMOUS]
MOVER:	Charles Markel, Councilmember
SECONDER:	Mary Holtz, Supervisor
AYES:	Holtz, Jaworowicz, Swiatek, Rogowski, Zydel, Markel, Kaznowski



15. RESOLUTION 2011-250

Approve 2011 Cultural Group Funding for Garden Club, Chorus & Historical Association

Sponsored By: Councilmember Rogowski, Councilmember Zydel

WHEREAS, the Town, in its 2011 budget, allocated moneys to certain cultural and not-for-profit organizations which are involved in activities which benefit the Town, and

WHEREAS, agreement(s) between the Town and these cultural and not-for-profit organizations have been prepared and forwarded to such groups, and

WHEREAS, the organization(s) listed below have completed and returned signed agreement(s) and their accounting report(s) from the 2010 funding to the Town, NOW, THEREFORE, BE IT

RESOLVED, that this Town Board hereby approves agreement(s) with the cultural and not-for-profit organization(s) listed below for the amount(s) listed, and BE IT FURTHER

RESOLVED, that the Supervisor be and hereby is authorized and directed to execute agreement(s) with the following referenced cultural and not-for-profit organization(s) for the following respective amount(s):

<u>Cultural/Not-For-Profit Organization</u>	<u>Funding Approved</u>
Cheektowaga Garden Club	\$ 625.00
Cheektowaga Community Chorus (76.9% residency)	\$12,000.00
Cheektowaga Historical Association	\$ 2,050.00

and BE IT FURTHER

RESOLVED, that the aforementioned moneys shall be paid to the respective cultural/not-for-profit organization(s) out of the respective cultural group budget line item(s) in the 2011 Town budget, subject to audit and approval of a properly signed Town voucher.

RESULT:	ADOPTED [UNANIMOUS]
MOVER:	James Rogowski, Councilmember
SECONDER:	Richard Zydel, Councilmember
AYES:	Holtz, Jaworowicz, Swiatek, Rogowski, Zydel, Markel, Kaznowski



16. RESOLUTION 2011-251

Approve Health Insurance Plan

Sponsored By: Councilmember Swiatek, Supervisor Holtz

WHEREAS, the Town of Cheektowaga would like to renew its health insurance contract with Blue Cross Blue Shield, NOW THEREFORE, BE IT

RESOLVED, that this Town Board hereby approves the contents of the one (1) year health insurance contract with Blue Cross Blue Shield, and BE IT FURTHER

RESOLVED, that this health insurance plan and contract shall be effective as of June 1, 2011, and BE IT FURTHER

RESOLVED, that the Supervisor be and hereby is authorized and directed to execute the new health insurance contract with Blue Cross Blue Shield, and any and all other documents necessary to effectuate the insurance coverage called for under such contract.

RESULT:	ADOPTED [UNANIMOUS]
MOVER:	Jeff Swiatek, Councilmember
SECONDER:	Mary Holtz, Supervisor
AYES:	Holtz, Jaworowicz, Swiatek, Rogowski, Zydel, Markel, Kaznowski



17. RESOLUTION 2011-252

Agreement with Cheektowaga Libraries

Sponsored By: Councilmember Zydel, Councilmember Rogowski

WHEREAS, The Cheektowaga Department of Youth and Recreational Services is desirous of continuing the operation of a joint program with the Cheektowaga Public Library System at Cheektowaga's two branch libraries, to provide special activities that encourage children to read and become more familiar with the library, and

WHEREAS, said program is open to all Cheektowaga youth regardless of race, color or creed, NOW, THEREFORE, BE IT

RESOLVED that the Supervisor be and hereby is authorized to execute an agreement between the Town of Cheektowaga and the Cheektowaga Public Library System to continue said program for a twelve (12) month period, January 1, 2011 through December 31, 2011 with a total cost not to exceed \$2,200.00.

CONTRACT # (BUDGET LINE ITEM) 01-7310-4675

RESULT:	ADOPTED [UNANIMOUS]
MOVER:	Richard Zydel, Councilmember
SECONDER:	James Rogowski, Councilmember
AYES:	Holtz, Jaworowicz, Swiatek, Rogowski, Zydel, Markel, Kaznowski



18. RESOLUTION 2011-253

Authorize Disposal of Obsolete Computer Equipment

Sponsored By: Councilmember Markel, Supervisor Holtz

WHEREAS, the Town wishes to dispose of a number of various computers, monitors, printers, drives, and fax machines which are obsolete, unusable, and have no market value, all of which contain hazardous materials (i.e., lead, mercury, etc.) and must be disposed of in an environmentally sound manner; and

WHEREAS, the disposal of such property is authorized by Section 64 of the Town Law of the State of New York; and

WHEREAS, Regional Computer Recycling & Recovery of Victor, New York will pick-up said equipment and dispose of same in full compliance with all government regulations applicable to the disposal of hazardous waste, at a cost of \$5.00 per monitor and a per-pallet charge at an approximate total cost to the Town of \$250.00; NOW THEREFORE, BE IT

RESOLVED, that the Town hereby authorizes Regional Computer Recycling and Recovery to take possession of the equipment set forth below and dispose of same in full compliance with all applicable federal and state regulations governing the disposal of hazardous waste; BE IT FURTHER

RESOLVED, that the Supervisor of the Town of Cheektowaga be and hereby is authorized to execute any document necessary effect the proper disposal of said equipment; and BE IT FURTHER

RESOLVED, that the cost associated with the disposal of said equipment shall be appropriated from account number 100-1680-4147.

OBSOLETE COMPUTER EQUIPMENT FOR DISPOSAL

MAKE	MODEL	SERIAL NUMBER
DELL	OPTIPLEX 260	JL7JN21
DELL	OPTIPLEX 240	2T4JG11
DELL	OPTIPLEX 240	4T4JG11
DELL	OPTIPLEX 240	HS4JG11
DELL	OPTIPLEX 240	FS4JG11
DELL	OPTIPLEX 260	2M7JN21
DELL	OPTIPLEX 240	1S4JG11
DELL	OPTIPLEX 270	603FN41
HP	1012 PRINTER	CNFB692875
MITSUBISHI	DIAMOND POINT	41136506NA
MITSUBISHI	DIAMOND POINT	41136540NA
MITSUBISHI	DIAMOND POINT	41136545NA
MITSUBISHI	DIAMOND POINT	41136505NA
MITSUBISHI	DIAMOND POINT	41136500NA

SAMSUNG		MJ17HVFY716324J
SAMSUNG		MJ17LSKB
SAMSUNG		MJ17HVFY71636H
DELL	E173FP	CN0F5035641804BN3JYS
MITSUBISHI	V50LCD-BK	41136507NA
HP	LASERJET 5000	USB3002450
HP	LASERJET 1006	VNB3228753
HP	LASERJET P3005N	CNJ2R01409
HP	DESKJET F4140	CN7683M172
DELL	OPTIPLEX GX520	HWG9W91
DELL	OPTIPLEX GX520	J7K1W91
DELL	OPTIPLEX GX520	5YG9W91
DELL	17" MONITOR	CN0CJ167728726BG2144
COMPAQ	MONITOR 1520	CN3091K350
DELL	15" MONITOR	CN0M16196418042Q2CAS
DELL	15" MONITOR	CN0M16196418042Q2CLS
OPTIQUEST	MONITOR Q191WB	QY5074400478
IOMEGA	ZIP 100	RA9F38027B
TRIP LITE	BC450	16-16359G1589509685
DELL	OPTIPLEX 270	G3XLN41
DELL	OPTIPLEX 270	73XLN41
DELL	OPTIPLEX 270	FJ36241
DELL	OPTIPLEX 270	6B9L931
DELL	OPTIPLEX 270	5M36241
DELL	OPTIPLEX 270	FV54H31
HP	LASERJET 1018	CNB1508915
HP	LASERJET 1012	CNBK106781
HP	LASERJET 4600 DN	JPBGC23795
HP	OFFICE JET	MY72R710WS
HP	LASERJET 4250 DTN	CNGXG15675
HP	LASERJET 6P	USCH035690
HP	LASERJET 1018	CNB1508903
HP	LASERJET 1012	CNBJH10473
NIGHTOWL	ENHANCER	112901
AEG OLYMPIA	MASTER TYPE 100	
HP	LASERJET 4000	USMB033353
HP	OFFICE JET G85	SGA015G2TY
PANASONIC	MONITOR WV-CM1780	V7MH1093C3
PRO SERIES	MAGNIN TELECORDER	1180702323
MITSUBISHI	DIAMOND POINT	41136506NA
MITSUBISHI	DIAMOND POINT	41136545NA
MITSUBISHI	DIAMOND POINT	41136505NA
MITSUBISHI	DIAMOND POINT	41136540NA
MITSUBISHI	DIAMOND POINT	41136507NA
MITSUBISHI	DIAMOND POINT	41136500NA
SAMSUNG	SYNCMaster 710N	MJ17HVFY716336H
HP	MONITOR MX90	THLBU00799
DELL	MONITOR P992	MX08D466477412BS81HC
DELL	MONITOR P992	MX08D466477412BB406D

DELL	MONITOR P992	MX08D466477412BB406B
DELL	MONITOR P992	MX08D466477412BB406C
DELL	PRECISION 360	5XLJP41
DELL	PRECISION 360	8WLJP41
DELL	PRECISION 360	JWLJP41
HP	PAVILLION 9870	US05359168
DELL	PRINTER 1700N	CN0J4476487304BH48VL
HP	LASERJET 2300D	CNBFC36588
DELL	MONITOR E776	MX0419TG47801231H2LJ
COMPAQ	MONITOR	228CR26HA451
ELMO	MONITOR	08590980
SOCOS	MONITOR	BB6728C09989
OKIDATA	MICROLINE	18455AY31429136
HP	LASERJET 2300DN	CNBF31286
BC PRO	POWER BACKUP	D02309191
DELL	MONITOR	CN0CJ167728726BG2144
DELL	OPTIPLEX GX520	34G9W91
DELL	OPTIPLEX GX520	CWG9W91
DELL	MONITOR P992	MX08D466477412BB406A
DELL	OPTIPLEX 170	2LKSR81
DELL	DIMENSION	FDLX01
DELL	OPTIPLEX 755	74N5HJ1
DELL	INSPIRON 8500	5Q5B531
HP	LASERJET 3055	CNRK168331
DELL	MONITOR M781S	MX058VYR4760519BAKY7
BROTHER	FAX 1860C	U61588K7F746900
VIEW SONIC	70 MB MONITOR	60H013101436
VIEW SONIC	70 MB MONITOR	241032553051
SONIC BLUE	VCR DDV 3120	222312001740
EPSON	PRINTER C84	FBLY160676
EPSON	PRINTER 980	CLQ1707026
SAMSUNG	FAX MSYS5150	B1FK300113V
DELL	OPTIPLEX GX 240	6T4JG11
DELL	OPTIPLEX GX 520	40H9W91
DELL	MONITOR	CN0GP0047287281P03CS

RESULT:	ADOPTED [UNANIMOUS]
MOVER:	Charles Markel, Councilmember
SECONDER:	Mary Holtz, Supervisor
AYES:	Holtz, Jaworowicz, Swiatek, Rogowski, Zydel, Markel, Kaznowski



19. RESOLUTION 2011-254

Purchase of Park Equipment for Alexander Com. Center

Sponsored By: Councilmember Zydell, Councilmember Rogowski

WHEREAS, The Youth & Recreational Services Department has requested authorization to purchase Playground Equipment for the Alexander Community Center, as specified in New York State OGS Contracts PC62097, AND

WHEREAS, funds for said purchase have been budgeted and are available under the following account numbers:

100.0100.7140.4024
100.0100.7140.4025
100.0100.7310.4431
100.0100.0082
600.0600.0893

RESOLVED, that the Town Board hereby authorizes the purchase of Park Equipment, as detailed on the attached quotation for the Alexander Community Center in the amount of \$21,138.60 from:

PARKITECTS, Inc.
138 Ludlowville Road, #1
Lansing, NY 14882

Attachments:

Alexander Comm Center_Prop (PDF)

RESULT: ADOPTED [UNANIMOUS]
MOVER: Richard Zydell, Councilmember
SECONDER: James Rogowski, Councilmember
AYES: Holtz, Jaworowicz, Swiatek, Rogowski, Zydell, Markel, Kaznowski



20. RESOLUTION 2011-255

Summer Youth Theater Program at Villa Maria

Sponsored By: Councilmember Zydel, Councilmember Rogowski

WHEREAS, the Department of Youth and Recreational Services is desirous of holding its Summer Youth Theater Program June 27th and August 4th at Villa Maria College, and

WHEREAS, the College has offered use of its recital hall and auditorium for the above mentioned program, NOW, THEREFORE BE IT

RESOLVED, that upon approval by the Town Attorney, the Supervisor be and hereby is authorized and directed to execute a no cost rental agreement with Villa Maria College for the Youth & Recreational Services Department "Over the Edge" Summer Theater Program.

RESULT:	ADOPTED [UNANIMOUS]
MOVER:	Richard Zydel, Councilmember
SECONDER:	James Rogowski, Councilmember
AYES:	Holtz, Jaworowicz, Swiatek, Rogowski, Zydel, Markel, Kaznowski



21. RESOLUTION 2011-256

Retain Nussbaumer & Clarke, Inc. for Construction Phase Services

Sponsored By: Supervisor Holtz, Councilmember Swiatek

WHEREAS, in conjunction with the award of bid of the contract for the Installation of Solar Power Systems on Various Town Buildings, the Town Engineer has recommended that Nussbaumer & Clarke, Inc., the project design consultant, be retained to perform Construction Phase Services throughout the duration of the project as outlined in a proposal dated April 6, 2011, NOW, THEREFORE, BE IT

RESOLVED, that the proposal of Nussbaumer & Clarke, Inc., 3556 Lake Shore Road, Suite 500, Buffalo, New York 14219-1494 as submitted to the Town Engineer for professional services during construction is accepted and approved AND, BE IT FURTHER

RESOLVED, that the Supervisor, on behalf of this Town Board, is hereby directed and authorized to sign said agreement for the aforesaid professional services in an amount not to exceed \$27,000.00 and shall be chargeable to Account #500-1440-9701-5021.

RESULT:	ADOPTED [UNANIMOUS]
MOVER:	Mary Holtz, Supervisor
SECONDER:	Jeff Swiatek, Councilmember
AYES:	Holtz, Jaworowicz, Swiatek, Rogowski, Zydel, Markel, Kaznowski



22. RESOLUTION 2011-257

Appoint William R. Pugh, P.E., Project Manager for the Rein Road Bridge Rehabilitation Project

Sponsored By: Councilmember Swiatek, Supervisor Holtz

WHEREAS, the Town of Cheektowaga was awarded a grant for Federal Highway Bridge Rehabilitation and Replacement (HBRR) funds to rehabilitate the Rein Road Bridge over Ellicott Creek, PIN 5758.38, which grant is required to be administered in accordance with New York State Department of Transportation guidelines and procedures for Locally Administered Federal Aid Projects, AND

WHEREAS, the grant administration guidelines require the Town to assign a Project Manager for this project, AND

WHEREAS, William R. Pugh, P.E., Town Engineer, is familiar with this project and is qualified to act as Project Manager, NOW, THEREFORE, BE IT

RESOLVED, that William R. Pugh, P.E., Town Engineer, be and hereby is appointed Project Manager for the Rein Road over Ellicott Creek Bridge Rehabilitation Project.

RESULT:	ADOPTED [UNANIMOUS]
MOVER:	Jeff Swiatek, Councilmember
SECONDER:	Mary Holtz, Supervisor
AYES:	Holtz, Jaworowicz, Swiatek, Rogowski, Zydel, Markel, Kaznowski



23. RESOLUTION 2011-258

Designate a Consultant Selection Committee for the Rein Road Bridge Rehabilitation Project

Sponsored By: Councilmember Swiatek, Supervisor Holtz

WHEREAS, the Town of Cheektowaga was awarded a grant for Federal Highway Bridge Rehabilitation and Replacement (HBRR) Funds to rehabilitate the Rein Road Bridge over Ellicott Creek, PIN 5758.38, which grant is required to be administered in accordance with New York State Department of Transportation guidelines and procedures for Locally Administered Federal Aid Projects, AND

WHEREAS, under the Procedures for Locally Administered Federal Aid Projects the Town is required to retain a consultant to design the project and to designate individuals to serve on a Consultant Selection Committee, NOW, THEREFORE, BE IT

RESOLVED, that the following individuals be and hereby are designated to serve as the Town's representatives on the Consultant Selection Committee based on their expression of interest:

Patrick T. Bowen, P.E.
Assistant Town Engineer

Allan B. Blachowski
Junior Civil Engineer

Gail Milburth
Senior Engineer Assistant

John Marriott
Chairman, Town Planning Board

Paul Gasiewicz
Traffic Safety Commission Member

AND, BE IT FURTHER

RESOLVED, that the Consultant Selection Committee's recommendation, following evaluation of consultant qualifications, shall be submitted to the New York State Department of Transportation Project Coordinator for approval.

RESULT:	ADOPTED [UNANIMOUS]
MOVER:	Jeff Swiatek, Councilmember
SECONDER:	Mary Holtz, Supervisor
AYES:	Holtz, Jaworowicz, Swiatek, Rogowski, Zydel, Markel, Kaznowski



24. RESOLUTION 2011-259

Dedication of “Norm Bealer Way”

Sponsored By: Councilmember Zydel, Councilmember Rogowski

WHEREAS, the Town of Cheektowaga is the owner of parkland known as Volunteer Firemans Memorial Park located on the north side of Losson Road east of John C. Stiglmeier Park and south of the Dr. Victor Reinstein Nature Preserve, and

WHEREAS, many events and activities are held at this Park in honor of the volunteer firefighters who serve our community, and

WHEREAS, Norm Bealer lived in front of the Volunteer Fireman’s Memorial Park for years and helped to clean up and maintain the park, and

WHEREAS, Norm Bealer also attended meetings of the Central Council of Firefighters and was well-respected by the volunteer firefighters of Cheektowaga, and

WHEREAS, Mr. Bealer was a friend and advocate for volunteer firefighters and the Volunteer Firemans Memorial Park, and

WHEREAS, in 2010, Mr. Bealer passed away, and

WHEREAS, the Central Council of Firefighters has requested that this Board name the entrance road to Fireman’s Park “Norm Bealer Way” in honor of Mr. Bealer, and

WHEREAS, this Board feels that this tribute is well-deserved, NOW, THEREFORE, BE IT

RESOLVED, that the entrance road to the Town of Cheektowaga Volunteer Fireman’s Memorial Park be and hereby is dedicated as “Norm Bealer Way”, and BE IT FURTHER

RESOLVED, that the Director of the Facilities Department be and hereby is directed to erect a sign identifying this road as “Norm Bealer Way”.

RESULT:	ADOPTED [UNANIMOUS]
MOVER:	Richard Zydel, Councilmember
SECONDER:	James Rogowski, Councilmember
AYES:	Holtz, Jaworowicz, Swiatek, Rogowski, Zydel, Markel, Kaznowski



25. RESOLUTION 2011-260

Creation of Four (4) Police Dispatcher (Part-Time/Non-Competitive) Positions

Sponsored By: Councilmember Jaworowicz, Councilmember Swiatek

BE IT RESOLVED, that this Town Board hereby create four (4) Police Dispatcher (Part Time) positions pursuant to Civil Service Laws and Regulations effective May 3, 2011.

RESULT:	ADOPTED [UNANIMOUS]
MOVER:	Patricia Jaworowicz, Councilmember
SECONDER:	Jeff Swiatek, Councilmember
AYES:	Holtz, Jaworowicz, Swiatek, Rogowski, Zydel, Markel, Kaznowski



26. RESOLUTION 2011-261

Hiring/Termination of Part-Time/Seasonal Employees

Sponsored By: Councilmember Swiatek, Supervisor Holtz

BE IT RESOLVED, that the following individuals be and hereby are hired as **SEASONAL EMPLOYEES**, not to exceed five (5) months in a calendar year, in the various departments listed and in compliance with Civil Service Laws and Regulations as well as the provisions of the Town's collective bargaining agreement between the Town of Cheektowaga and the Town of Cheektowaga Employees Association:

SANITATION DEPARTMENT Laborer \$8.00/hour effective 4/18/11

Nicholas C. Scaccia, Cheektowaga, New York

Joshua R. Loucks, Cheektowaga, New York

Charles J. McFayden, Jr., Cheektowaga, New York

Tyler D. Schaf, Cheektowaga, New York

Walter W. Szafraniec, Cheektowaga, New York

Robert F. Vesona, Depew, New York

FACILITIES DEPARTMENT (Building Maintenance Division) Laborer \$8.00/hour effective 5/3/11

Adam T. Paradowski, Cheektowaga, New York

BE IT RESOLVED, that the following individuals be and hereby are hired as **PART-TIME EMPLOYEES** in the departments listed, not to exceed nineteen (19) hours on a weekly basis, in compliance with Civil Service Laws and Regulations as well as the provisions of the Town's collective bargaining agreement between the Town of Cheektowaga and the Town of Cheektowaga Employees Association:

SANITATION DEPARTMENT Laborer \$8.00/hour effective 4/18/11

Keith Piatek, Sloan, New York

POLICE DEPARTMENT Police Dispatcher \$16.10/hour effective 5/3/11

Jeffrey M. Filipski, Cheektowaga, New York

Daniel P. Malkowski, Cheektowaga, New York

Timothy Bull, Cheektowaga, New York

Richard C. Littler, Cheektowaga, New York

BE IT RESOLVED, that the following seasonal and/or part-time employees be and hereby are terminated as listed:

SANITATION DEPARTMENT (Laborer)

Charles J. McFayden, Jr. effective 4/19/11

POLICE DEPARTMENT (Clerk)

Jeffrey M. Filipski effective 5/2/11

Motion by Councilmember Markel; Seconded by Supervisor Holtz to waive the Reading of Names for this resolution. Motion Carried.

RESULT: **ADOPTED [UNANIMOUS]**

MOVER: Jeff Swiatek, Councilmember

SECONDER: Mary Holtz, Supervisor

AYES: Holtz, Jaworowicz, Swiatek, Rogowski, Zydel, Markel, Kaznowski



27. RESOLUTION 2011-262

Authorize Student Intern for Police Department (Molnar)

Sponsored By: Councilmember Jaworowicz, Councilmember Swiatek

WHEREAS, Jamie Molnar, a student at Hilbert College, has requested to participate in the student internship program at the Cheektowaga Police Department; AND

WHEREAS, Ms. Molnar has been interviewed by the Police Department and the Department is willing to afford her the opportunity to intern in the Police Department; NOW, THEREFORE, BE IT

RESOLVED, that Jamie Molnar, of Getzville, New York be and hereby is authorized to participate as an unpaid intern in the Cheektowaga Police Department Crime Resistance Unit, from August 1, 2011 to December 31, 2011, subject to her execution of a Waiver of Liability and Agreement of Confidentiality; AND BE IT FURTHER

RESOLVED, that the Supervisor be and hereby is authorized and directed to execute the Agreement of Confidentiality, and all other documents necessary to effectuate this student internship in the Police Department.

RESULT:	ADOPTED [UNANIMOUS]
MOVER:	Patricia Jaworowicz, Councilmember
SECONDER:	Jeff Swiatek, Councilmember
AYES:	Holtz, Jaworowicz, Swiatek, Rogowski, Zydel, Markel, Kaznowski



28. RESOLUTION 2011-263

Authorize Student Intern for Police Department (Evans)

Sponsored By: Councilmember Jaworowicz, Councilmember Swiatek

WHEREAS, Dawn Evans, a student at Hilbert College, has requested to participate in the student internship program at the Cheektowaga Police Department; AND

WHEREAS, Ms. Evans has been interviewed by the Police Department and the Department is willing to afford her the opportunity to intern in the Police Department; NOW, THEREFORE, BE IT

RESOLVED, that Dawn Evans of Kenmore, New York be and hereby is authorized to participate as an unpaid intern in the Cheektowaga Police Department Crime Resistance Unit, from August 1, 2011 to December 31, 2011, subject to her execution of a Waiver of Liability and Agreement of Confidentiality; AND, BE IT FURTHER

RESOLVED, that the Supervisor be and hereby is authorized and directed to execute the Agreement of Confidentiality, and all other documents necessary to effectuate this student internship in the Police Department.

RESULT:	ADOPTED [UNANIMOUS]
MOVER:	Patricia Jaworowicz, Councilmember
SECONDER:	Jeff Swiatek, Councilmember
AYES:	Holtz, Jaworowicz, Swiatek, Rogowski, Zydel, Markel, Kaznowski

**29. RESOLUTION 2011-264****Travel Authorization (Senior Services)/Director of Senior Services Kerry Switalski**

Sponsored By: Councilmember Swiatek, Supervisor Holtz

WHEREAS, the Aging Concerns Unite Us (ACUU) Conference is being held June 7-8, 2011 in Albany, New York; AND

WHEREAS, Director of Senior Services Kerry Switalski has requested authorization to attend said conference; AND

WHEREAS, Ms. Switalski has submitted a request for travel authorization along with the proper paperwork in a timely manner; AND

WHEREAS, the total cost to the Town shall not exceed \$590; AND

WHEREAS, these expenses have been budgeted by the Department of Senior Services; NOW, THEREFORE, BE IT

RESOLVED, that Director of Senior Services Kerry Switalski be and hereby is authorized to attend the Aging Concerns Unite Us (ACUU) Conference being held June 7-8, 2011 in Albany, New York.

RESULT:	ADOPTED [UNANIMOUS]
MOVER:	Jeff Swiatek, Councilmember
SECONDER:	Mary Holtz, Supervisor
AYES:	Holtz, Jaworowicz, Swiatek, Rogowski, Zydel, Markel, Kaznowski



30. RESOLUTION 2011-265

Travel Authorization (Employee Relations)/Coordinator of Employee Relations Anthony Romano

Sponsored By: Councilmember Swiatek, Supervisor Holtz

WHEREAS, the New York State Public Employer Labor Relations Association 37th Annual Training Conference is being held July 20-22, 2011 in Saratoga Springs, New York; AND

WHEREAS, Coordinator of Employee Relations Anthony Romano has requested authorization to attend said conference; AND

WHEREAS, Mr. Romano has submitted a request for travel authorization along with the proper paperwork in a timely manner; AND

WHEREAS, the total cost to the Town shall not exceed \$1,024; AND

WHEREAS, these expenses have been budgeted by the Personnel Department; NOW, THEREFORE, BE IT

RESOLVED, that Coordinator of Employee Relations Anthony Romano be and hereby is authorized to attend the New York State Public Employer Labor Relations Association 37th Annual Training Conference being held July 20-22, 2011 in Saratoga Springs, New York.

RESULT:	ADOPTED [UNANIMOUS]
MOVER:	Jeff Swiatek, Councilmember
SECONDER:	Mary Holtz, Supervisor
AYES:	Holtz, Jaworowicz, Swiatek, Rogowski, Zydel, Markel, Kaznowski



31. RESOLUTION 2011-266

Travel Authorization (Police Department)/Police Chief David Zack, Captain Michael Isbrandt and Captain Michael Sliwinski

Sponsored By: Councilmember Jaworowicz, Councilmember Swiatek

WHEREAS, the 18th Annual CALEO (Canadian American Law Enforcement Organization) Training Symposium is being held June 1-3, 2011 in Niagara Falls, Ontario; AND

WHEREAS, Police Chief David Zack, Captain Michael Isbrandt and Captain Michael Sliwinski have requested authorization to attend said symposium; AND

WHEREAS, Police Chief David Zack has submitted a request for travel authorization along with the proper paperwork in a timely manner; AND

WHEREAS, the total cost to the Town shall not exceed \$1,381; AND

WHEREAS, these expenses have been budgeted by the Police Department; NOW, THEREFORE, BE IT

RESOLVED, that Police Chief David Zack, Captain Michael Isbrandt and Captain Michael Sliwinski be and hereby are authorized to attend the 18th Annual CALEO (Canadian American Law Enforcement Organization) Training Symposium being held June 1-3, 2011 in Niagara Falls, Ontario.

RESULT:	ADOPTED [UNANIMOUS]
MOVER:	Patricia Jaworowicz, Councilmember
SECONDER:	Jeff Swiatek, Councilmember
AYES:	Holtz, Jaworowicz, Swiatek, Rogowski, Zydel, Markel, Kaznowski

V. Communications

A. Departmental Communications

1. Supervisor's Statement of Funds - March 2011
2. Building Permits - April 2011
3. Drescher & Malecki, LLP: Annual Financial Report for the Town of Cheektowaga for the Fiscal Year Ended 12/31/2010
4. Minutes: Cheektowaga Traffic Safety Commission - March 15, 2011
5. Minutes: Cheektowaga Public Library - Board of Trustees - March 16, 2011
6. Minutes: Cheektowaga Conservation Advisory Council - April 7, 2011

B. General Communications

1. Notice of Claim: CTS Contracting Inc. F/K/A Custom Topsoil Inc. Vs. Town of Cheektowaga
2. Notice of Claim: Niagara Mohawk Power Corp DbA National Grid Vs. Town of Cheektowaga
3. Notice of Highway Restriction and Closure: Aero Drive Will be Closed in Both Directions from Youngs to Transit in Order to Place Binder in the Roundabout. the Closure Will be in Effect from Tuesday, April 26, 2011 through Friday, April 29, 2011; No Traffic Will be Permitted through the Roundabout.
4. Notice of Highway Restriction and Closure: Holtz Drive Will Continue to be Closed in Both Directions from Genesee to Aero Drive for Excavation Purposes. the Closure Will be in Effect from Monday, April 25, 2011 through Friday, April 29, 2011; Local Traffic Only to Pass.

VI. Comments

A. Supervisor's Comments

B. Councilmember's Comments

C. Public Comments

VII. Adjournment

Motion by Supervisor Holtz; Seconded by Councilmember Swiatek to adjourn the meeting in Memory of Patricia Wojcik, retired Senior Services Director.

Alice Magierski, Town Clerk



Please remit payment to:

PARKITECTS Inc.
138 Ludlowville Rd, Lansing NY 14882
1 (800) 726-4833 • fax.(607) 533- 4108

Proposal

To: **Ellen Fischer**
Town of Cheektowaga
Phone: 716-897-6647
Fax: 716-897-7211

Bill To: _____

Date: 04, April 2011

From: **Ben Frasier**
Ph/Fax: 716-886-8647

Ship To: _____

Re: **Alexander Community Center**
Playground Equipment

Qty.	Item No.	Description	Unit Price	Amount
Playground Equipment Under New York State Contract #PC62097				
1	Design 33EZ	PlaySense Design 33EZ		\$10,115.00
1		4-Seat See Saw, DB		2,315.00
1		Fire Engine Spring Rider		1,235.00
1		Rhino Dino Spring Rider		835.00
2		Saddle Spinner	\$785.00	1,570.00
1		OmniSpin Spinner		<u>5,500.00</u>
		Equipment Total		\$21,570.00
		Less NY State Contract Discount		(431.40)
		Freight (\$1,700.00)		<u>No Charge</u>
		Order Total		\$21,138.60

Attachment: Alexander Comm Center_Prop (RES-2011-254 : Purchase of Park Equipment for Alexander Com. Cent)

PRICES ARE VALID FOR 60 DAYS

Terms: 50% Deposit/Net 30
Net 30 for Municipal/Nonprofit Agencies

Order Requirements: 50% Deposit
Completed proposal (Bill to, Ship to, Delivery info, Accepted by)
Tax exempt certificate, if applicable

Delivery Contact Name _____ Phone Number _____

Accepted by Customer _____ Date _____

Print Name _____



Town of Cheektowaga

Regular Meeting

~ Minutes ~

3301 Broadway
Cheektowaga, NY 14227
<http://www.town.cheektowaga.ny.us>

Alice Magierski
716-686-3400

Monday, May 16, 2011

6:45 PM

Council Chambers

I. Call to Order

6:45 PM Meeting called to order on May 16, 2011 at Council Chambers, 3301 Broadway St, Cheektowaga, NY.

Attendee Name	Organization	Title	Status	Arrived
Mary Holtz	Town of Cheektowaga	Supervisor	Present	
Patricia Jaworowicz	Town of Cheektowaga	Councilmember	Present	
Jeff Swiatek	Town of Cheektowaga	Councilmember	Present	
James Rogowski	Town of Cheektowaga	Councilmember	Present	
Richard Zydel	Town of Cheektowaga	Councilmember	Present	
Charles Markel	Town of Cheektowaga	Councilmember	Present	
Stanley Kaznowski	Town of Cheektowaga	Councilmember	Present	

2. Additional Attendees

Thomas Adamczak, Supervising Building and Plumbing Inspector
Brian Krause, Director of Finance and Administration
John Marriott, Planning Board Chairman
William Pugh, Town Engineer
Anthony Romano, Coordinator of Employee Relations
Kevin Schenk, Town Attorney
David Zack, Chief of Police

II. Public Comment Period

III. Public Hearings

1. Rezoning Request

83 Anderson Road and Part of 61 Anderson Road

This being the time and place advertised for a Public Hearing, the Supervisor directed the Town Clerk to present that such notice has been duly published and posted; upon the order of the Supervisor such proof was duly filed.

The Supervisor announced that the Town Board would hear all persons interested in the subject of the hearing. Comments were heard, after which the Supervisor declared the hearing closed, decision was reserved.

RESULT: CLOSED [UNANIMOUS]
MOVER: James Rogowski, Councilmember

SECONDER: Charles Markel, Councilmember

AYES: Holtz, Jaworowicz, Swiatek, Rogowski, Zydel, Markel, Kaznowski

IV. Resolutions



1. RESOLUTION 2011-267

Transfer of Funds

Sponsored By: Supervisor Holtz, Councilmember Swiatek

BE IT RESOLVED, that the following transfer is hereby approved and made a part hereof;

2010

GENERAL FUND

FROM:	100.1910.4591	NSP Grant Revenues	\$ 118,316.02
TO:	100.1910.4721	NSP Grant Expenditures	\$ 118,316.02

RESULT:	ADOPTED [UNANIMOUS]
MOVER:	Mary Holtz, Supervisor
SECONDER:	Jeff Swiatek, Councilmember
AYES:	Holtz, Jaworowicz, Swiatek, Rogowski, Zydel, Markel, Kaznowski



2. RESOLUTION 2011-268

Transfer of Funds 2011

Sponsored By: Supervisor Holtz, Councilmember Swiatek

BE IT RESOLVED, that the following transfer is hereby approved and made a part hereof;

2011

GENERAL FUND

FROM:	100.7140.2123	Ice Rentals	\$	276.00
	100.7140.2123	Ice Rentals		241.50
	100.7510.4052	Printing Historical Material		525.00
TO:	100.7110.1902	Facilities Overtime	\$	276.00
	100.7110.1902	Facilities Overtime		241.50
	100.7510.4043	Maps, Records & Supplies		525.00

PART TOWN FUND

FROM:	800.8020.4001	Office Supplies	\$	125.00
TO:	800.8020.4192	Other Expenses	\$	125.00

HUD CDBG FUND

FROM:	700.1008.0704	Contingency	\$	931.70
	700.1009.0684	Fair Housing		1,500.00
TO:	700.1008.0603	Environmental Testing	\$	931.70
	700.1009.0603	Environmental Testing		1,500.00

RESULT:	ADOPTED [UNANIMOUS]
MOVER:	Mary Holtz, Supervisor
SECONDER:	Jeff Swiatek, Councilmember
AYES:	Holtz, Jaworowicz, Swiatek, Rogowski, Zydel, Markel, Kaznowski



3. RESOLUTION 2011-269

Warrant

Sponsored By: Supervisor Holtz, Councilmember Swiatek

BE IT RESOLVED, that the following Vouchers & Warrants submitted to the Town of Cheektowaga prior to May 13, 2011 are hereby approved and made a part hereof;

GENERAL FUND	\$ 355,040.87
RISK RETENTION FUND	15,742.97
NYS HOME PROGRAM	700.00
SPECIAL DISTRICTS FUND	215,721.44
HIGHWAY FUND	17,141.96
CAPITAL FUND	279,443.59
TRUST & AGENCY FUND	1,768.21
HUD CDBG FUND	5,197.14
PART TOWN FUND	3,156.22
NYS AFFORDABLE HOUSING	3,160.00
	<u>\$ 897,072.40</u>

RESULT: **ADOPTED [UNANIMOUS]**

MOVER: Mary Holtz, Supervisor

SECONDER: Jeff Swiatek, Councilmember

AYES: Holtz, Jaworowicz, Swiatek, Rogowski, Zydel, Markel, Kaznowski



4. RESOLUTION 2011-270

Award of Bid - Fencing

Sponsored By: Councilmember Rogowski, Supervisor Holtz

WHEREAS, a Notice to Bidders was published for the furnishing and installation of wood and chain link fencing and gates at the Town Hall Campus, which bids were duly received and opened on April 20, 2011, AND

WHEREAS, said bids were referred to the Town Engineer for analysis and tabulation, at which time it was determined that the long term maintenance of a 6' wood fence was not practical for the proposed location on the campus, NOW, THEREFORE, BE IT

RESOLVED, that the contract for the furnishing and installation of chain link fencing and two (2) gates be awarded to:

Excel Fence, Inc.
10760 Alleghany Road
Darien Center, New York 14040

for the bid price of \$11,020.08 (excluding all wood fencing), said being the lowest bid meeting the requirements of the specifications, AND, BE IT FURTHER

RESOLVED, that the Supervisor, on behalf of this Town Board, be and hereby is authorized and directed to execute a contract with Excel Fence, Inc., AND, BE IT FURTHER

RESOLVED, that funding for said project shall be appropriated from Account #500-1440-2061-5835.

RESULT:	ADOPTED [UNANIMOUS]
MOVER:	James Rogowski, Councilmember
SECONDER:	Mary Holtz, Supervisor
AYES:	Holtz, Jaworowicz, Swiatek, Rogowski, Zydel, Markel, Kaznowski



5. RESOLUTION 2011-271

Approval of Change Order No. 2 (General Construction Work) Police & Court Building

Sponsored By: Supervisor Holtz, Councilmember Rogowski

WHEREAS, the contract for General Construction Work for the Police & Court Building Renovations and Addition was awarded by Town Board Resolution dated September 7, 2010 to Burgio & Campofelice, Inc., 2570 Walden Avenue, Cheektowaga, New York 14225 in the amount of \$9,033,643.00, AND

WHEREAS, the project architect, Trautman Associates, and the Town Engineer have reviewed and recommended the approval of Change Order No. 2 (General Construction Work) which provides for an addition to the contract for work associated with the purchase, installation and coordination of furniture and fixtures in the new Dispatch Room as further outlined in the Change Order Documents, NOW, THEREFORE, BE IT

RESOLVED, that Change Order No. 2 (General Construction Work) for the Police and Court Building Renovations and Addition in the amount of \$66,271.00 as an addition to the contract of Burgio & Campofelice, Inc. be and hereby is approved, AND, BE IT FURTHER

RESOLVED, that the Supervisor is hereby authorized and directed to execute said Change Order Documents on behalf of this Town Board, AND, BE IT FURTHER

RESOLVED, that said Change Order No. 2 shall be chargeable to Account #500-1440-2528-5025.

RESULT:	ADOPTED [UNANIMOUS]
MOVER:	Mary Holtz, Supervisor
SECONDER:	James Rogowski, Councilmember
AYES:	Holtz, Jaworowicz, Swiatek, Rogowski, Zydel, Markel, Kaznowski



6. RESOLUTION 2011-272

Bond Resolution - Sidewalks

Sponsored By: Supervisor Holtz, Councilmember Swiatek

BOND RESOLUTION OF THE TOWN OF CHEEKTOWAGA, NEW YORK, ADOPTED MAY 16, 2011, AUTHORIZING THE RECONSTRUCTION OF CURBS, SIDEWALKS AND DRIVEWAY APRONS, STATING THE ESTIMATED MAXIMUM COST THEREOF IS \$310,000, APPROPRIATING SAID AMOUNT FOR SUCH PURPOSE, AND AUTHORIZING THE ISSUANCE OF \$310,000 SERIAL BONDS OF SAID TOWN TO FINANCE SAID APPROPRIATION

THE TOWN BOARD OF THE TOWN OF CHEEKTOWAGA, IN THE COUNTY OF ERIE, NEW YORK, HEREBY RESOLVES (by the favorable vote of not less than two-thirds of all the members of said Town Board) AS FOLLOWS:

Section 1. The Town of Cheektowaga, in the County of Erie, New York (herein called the "Town"), is hereby authorized to reconstruct various curbs, sidewalks and driveway aprons. The estimated maximum cost thereof, including preliminary costs and costs incidental thereto and the financing thereof, is \$310,000 and said amount is hereby appropriated for such purpose. The plan of financing includes the issuance of \$310,000 serial bonds of the Town to finance said appropriation, and the levy and collection of taxes on all the taxable real property in the Town to pay the principal of said bonds and the interest thereon as the same shall become due and payable.

Section 2. Serial bonds of the Town in the principal amount of \$310,000 are

hereby authorized to be issued pursuant to the provisions of the Local Finance Law, constituting Chapter 33-a of the Consolidated Laws of the State of New York (herein called the "Law"), to finance said appropriation.

Section 3. The following additional matters are hereby determined and declared:

(a) The period of probable usefulness applicable to the object or purpose for which said serial bonds are authorized to be issued is ten (10) years; however, the bonds authorized pursuant to this resolution and any bond anticipation notes issued in anticipation of the sale of said bonds, shall mature no later than five (5) years after the date of original issuance of said bonds or notes.

(b) The proceeds of the bonds herein authorized and any bond anticipation notes issued in anticipation of said bonds may be applied to reimburse the Town for expenditures made after the effective date of this resolution for the purpose for which said bonds are authorized. The foregoing statement of intent with respect to reimbursement is made in conformity with Treasury Regulation Section 1.150-2 of the United States Treasury Department.

(c) The proposed maturity of the bonds authorized by this resolution will not exceed five (5) years.

Section 4. Each of the bonds authorized by this resolution and any bond anticipation notes issued in anticipation of the sale of said bonds shall contain the recital of validity as prescribed by Section 52.00 of the Law and said bonds and any notes issued in anticipation of said bonds shall be general obligations of the Town, payable as to both principal and interest by general tax upon all the taxable real property within the Town without limitation of rate or amount. The faith and credit of the Town are hereby irrevocably pledged to the punctual payment of the principal of and interest on said bonds and any notes issued in anticipation of the sale of said bonds and provision shall be made annually in the budget of the

Town by appropriation for (a) the amortization and redemption of the bonds and any notes in anticipation thereof to mature in such year and (b) the payment of interest to be due and payable in such year.

Section 5. Subject to the provisions of this resolution and of the Law and pursuant to the provisions of Section 21.00 relative to the authorization of bonds with substantially level or declining annual debt service, Section 30.00 relative to the authorization of the issuance of bond anticipation notes and Section 50.00 and Sections 56.00 to 60.00 and Section 168.00 of the Law, the powers and duties of the Town Board relative to authorizing bond anticipation notes and prescribing the terms, form and contents and as to the sale and issuance of the bonds herein authorized, and of any bond anticipation notes issued in anticipation of said bonds, and the renewals of said bond anticipation notes, and as to the execution of agreements for credit enhancements, are hereby delegated to the Supervisor, the chief fiscal officer of the Town.

Section 6. The validity of the bonds authorized by this resolution, and of any notes issued in anticipation of the sale of said bonds, may be contested only if:

- (a) such obligations are authorized for an object or purpose for which the Town is not authorized to expend money, or
- (b) the provisions of law which should be complied with at the date of the publication of such resolution, or a summary thereof, are not substantially complied with,

and an action, suit or proceeding contesting such validity is commenced within twenty days after the date of such publication, or

- (c) such obligations are authorized in violation of the provisions of the constitution.

Section 7. This bond resolution shall take effect immediately, and the Town Clerk is hereby authorized and directed to publish the foregoing resolution, in summary, together

with a Notice attached in substantially the form prescribed by Section 81.00 of the Law in “*Cheektowaga Bee*,” a newspaper having a general circulation within said Town and hereby designated as the official newspaper of the Town for such publication.

* * *

RESULT:	ADOPTED [UNANIMOUS]
MOVER:	Mary Holtz, Supervisor
SECONDER:	Jeff Swiatek, Councilmember
AYES:	Holtz, Jaworowicz, Swiatek, Rogowski, Zydel, Markel, Kaznowski



7. RESOLUTION 2011-273

Notice to Bidders - Sanitary Sewer Pipe

Sponsored By: Councilmember Kaznowski, Councilmember Zydel

WHEREAS, there is a need to purchase SDR-35 Sanitary Sewer Pipe, AND

WHEREAS, the Engineering Department is hereby requested to prepare specifications, NOW, THEREFORE, BE IT

RESOLVED, that this request be granted and that the Town Clerk be directed to publish a Notice to Bidders in connection with the furnishing of SDR-35 Sanitary Sewer Pipe, said notice to be published in the CHEEKTOWAGA BEE, AND, BE IT FURTHER

RESOLVED, that sealed bids will be received on the 1st day of June, 2011 at 11:00 am, at a public bid opening to be held in the Council Chambers in the Cheektowaga Town Hall.

NOTICE TO BIDDERS

Sealed proposals will be received by the Town of Cheektowaga on June 1, 2011 at 11:00 am at the Town Hall, corner of Broadway and Union Roads, for the purchase of up to 5,000 lin. feet of 21" sanitary sewer pipe.

Information for bidders and specifications may be obtained from the Town Clerk at her office in said Town.

The Town Board reserves the right to consider informal any bid not prepared and submitted in accordance with the provisions of the specifications and contract documents, and may waive any informalities, make an award to other than the low bidder, should it be in the best interest of the Town, or reject any or all bids.

By order of the Town Board of the Town of Cheektowaga, Erie County, New York.

Alice Magierski
Town Clerk

DATED: May 16, 2011

RESULT:	ADOPTED [UNANIMOUS]
MOVER:	Stanley Kaznowski, Councilmember
SECONDER:	Richard Zydel, Councilmember
AYES:	Holtz, Jaworowicz, Swiatek, Rogowski, Zydel, Markel, Kaznowski



8. RESOLUTION 2011-274

Notice to Bidders - One (1) New and Unused 2011 Water Way Maintenance and Rescue Vehicle

Sponsored By: Councilmember Swiatek, Supervisor Holtz

WHEREAS, the Town Clerk be and hereby is directed to publish a Notice to bidders for the purchase of ONE (1) NEW AND UNUSED 2011 WATER WAY MAINTENANCE AND RESCUE VEHICLE by the Highway Department.

Information for bidders and specifications may be obtained from the Office of the Town Clerk, Cheektowaga Town hall, Broadway and Union Roads, Cheektowaga, New York, between the hours of 9:00 AM and 4:30 PM, Monday through Friday, NOW THEREFORE, BE IT

RESOLVED, that the Town Clerk is hereby designated as the Office to open bids on the aforesaid items at a public bid opening to be held on June 1, 2011 at 11:00 AM, in the Council Chambers of the Cheektowaga Town Hall.

TOWN OF CHEEKTOWAGA HIGHWAY DEPARTMENT LEGAL NOTICE TO BIDDERS

NOTICE IS HEREBY GIVEN, that the Town of Cheektowaga Highway Department will receive bids for the purchase of One (1) New and Unused 2011 Water Way Maintenance and Rescue Vehicle for use by the Highway Department in the Town of Cheektowaga at a public bid opening to be held in the Council Chambers at the Cheektowaga Town Hall on June 1, 2011 at 11:00 A.M.

Information for bidders and specifications may be obtained from the office of Alice Magierski, Town Clerk at her office located at Town Hall, Cheektowaga NY. Bids must be enclosed in an opaque envelope plainly marked "BID FOR ONE (1) NEW AND UNUSED 2011 WATER WAY MAINTENANCE AND RESCUE VEHICLE." Non-Collusion forms must be signed and submitted with each bid. The Superintendent of Highways may reject any or all bids submitted.

Alice Magierski, TOWN CLERK

DATE: May 16, 2011

PUBLISHED: May 19, 2011

RESULT:	ADOPTED [UNANIMOUS]
MOVER:	Jeff Swiatek, Councilmember
SECONDER:	Mary Holtz, Supervisor
AYES:	Holtz, Jaworowicz, Swiatek, Rogowski, Zydel, Markel, Kaznowski



9. RESOLUTION 2011-275

Authorize Town Clerk to Issue New/Renewal Ambulance Drivers/Attendants Licenses

Sponsored By: Councilmember Zydel, Councilmember Jaworowicz

WHEREAS, on the 7th day of May, 1984, this Town Board adopted an Ambulance Ordinance. The EMS Board, which was created at that time, has completed a review and evaluation of new/renewal license applications for driver(s)/attendant(s), and has recommended that the Town Board issue such licenses, NOW, THEREFORE BE IT

RESOLVED, that the recommendations of the EMS Board concerning the licensing of new/renewal driver(s)/attendant(s) shown on the list below be and hereby are accepted and approved, for a period to expire upon the expiration of such ambulance driver(s)/attendant(s) Emergency Medical Technician ('EMT') card and, BE IT FURTHER

RESOLVED, that the Town Clerk be and hereby is authorized, empowered and directed to issue new/renewal licenses to the driver(s)/attendant(s) set forth on the annexed schedule, pursuant to the terms of this resolution.

TOWN OF CHEEKTOWAGA DRIVER/ATTENDANT LICENSE LIST

<u>Name</u>	<u>Expiration Date</u>
Barnack, Joseph F. , ,	2/28/2014
Cancel, Melissa R , ,	6/30/2013
Catanesi, Raymond J , ,	5/31/2014
Clemons, David C , ,	11/30/2013
Dudkowski, Michael A , ,	11/30/2013
Ewing, Jordan D , ,	2/28/2014
Faircloth, Shannon M , ,	3/31/2014
Freeburg, Lee A , ,	6/30/2012
Gibbons, Jacob D , ,	1/31/2014
Grabowski, Adam N , ,	2/28/2014
Green, Martin G , ,	2/28/2014
Greening, Daniel J , ,	7/31/2013
Grisanti, Michael J , ,	8/31/2013
Harris, Justin C , ,	7/31/2013
Harris, Tiffany E. , ,	1/31/2014
Holt, James B , ,	11/30/2013
Janicki, David A , ,	10/31/2013

Jurek, Matthew J.	, ,	3/31/2014
Koglmeier, Hubbard J	, ,	1/31/2014
Kowalski, Andrew J	, ,	1/31/2014
Lafferty, David J.	, ,	1/31/2014
Lockett, Antwan	, ,	1/31/2014
Mallen, Jesse D	, ,	9/30/2013
McCafferty, Peter T	, ,	7/31/2012
Miranto, Andreana	, ,	12/31/2013
Murtha, Leigh P	, ,	11/30/2013
Natalzia, Peter J	, ,	1/31/2014
Perkins, Nicole L	, ,	8/31/2013
Potoczak, Lynne M	, ,	1/31/2014
Pyra, Timothy R	, ,	3/31/2014
Rosenlund, Katharine E	, ,	1/31/2014
Ross, Michael	, ,	10/30/2013
Schweickert, Alisha M	, ,	1/31/2014
Seufert, Dylan R	, ,	6/30/2013
Thiemke, Stephen R	, ,	3/31/2014
Thoman, Matthew R.	, ,	2/28/2014
Wattie, Jeffery E.	, ,	3/31/2014
Windover, Scott P	, ,	4/30/2013
Yusuf, Afshar A	, ,	3/31/2014

RESULT:	ADOPTED [UNANIMOUS]
MOVER:	Richard Zydell, Councilmember
SECONDER:	Patricia Jaworowicz, Councilmember
AYES:	Holtz, Jaworowicz, Swiatek, Rogowski, Zydell, Markel, Kaznowski



10. RESOLUTION 2011-276

Authorize Town Clerk to Issue New/Renewal Ambulance Vehicle Licenses

Sponsored By: Councilmember Zydel, Councilmember Jaworowicz

WHEREAS, on the 7th day of May, 1984, this Town Board adopted an Ambulance Ordinance. The EMS Board, which was created at that time, has completed a review and evaluation of new/renewal license applications for ambulances and has recommended that the Town Board license such ambulance(s), NOW, THEREFORE, BE IT

RESOLVED, that the Town Board, pursuant to Section A-5 of the Ambulance Ordinance accept the recommendations of the Emergency Medical Services Board, and approve the list of vehicles and, BE IT FURTHER

RESOLVED, that the Town Clerk is hereby authorized, directed and empowered to issue ambulance licenses to the applicants set forth below, providing such ambulance(s) so listed meet(s) the insurance requirements set forth in the Ambulance Ordinance.

<u>VEHICLE MAKE & YEAR</u>	<u>LICENSE NO.</u>	<u>CALL NO.</u>
Ford 2002	CZD 1824	Medic-1
Chevrolet 2005	DDG 8519	Medic-10
Chevrolet 2005	DDG 8518	Medic-13
Chevrolet 2005	DDG 8521	Medic-14
Chevrolet 2003	DNJ 1293	Medic-15
Ford 2001	10600 ET	587
Ford 2001	10602 ET	588
Ford 2001	10601 ET	589
Ford 1998	10603 ET	590
Ford 1993	10647 ET	597
Ford 2005	10627 ET	573
Ford 2006	10614 ET	574
Ford 2006	10613 ET	575
Ford 2006	10641 ET	576
Ford 1993	12667 ET	577
Ford 2005	10628 ET	571
Ford 2005	10639 ET	572
Ford 1997	16738 ET	568
Ford 2005	10629 ET	570
Ford 1999	10626 ET	550
Ford 1996	10659 ET	555
Ford 1997	10200 EV	557
Ford 1995	12785 ET	558
Ford 1997	10654 ET	562
Ford 1997	12505 ET	565
Ford 1996	10632 ET	566

Ford 1999	16753 ET	567
Ford 1999	10675 ET	564
Ford 1997	12788 ET	252
Chevrolet 2010	12518 ET	259
Chevrolet 2010	12519 ET	260
Chevrolet 2010	12517 ET	261
Ford 1997	16764 ET	256
Chevrolet 2010	12793 ET	262
Chevrolet 2010	12777 ET	263
Chevrolet 2010	12776 ET	264
Chevrolet 2010	12775 ET	265
Ford 1999	16761 ET	351
Ford 2005	59009 JT	501
Ford 1997	10668 ET	502
Ford 1995	10666 ET	505
Chevrolet 2008	10664 ET	506
Chevrolet 2008	10619 ET	507
Chevrolet 2008	12500 ET	508
Ford 2000	10630 ET	510
Chevrolet 2007	10617 ET	512
Chevrolet 2007	10615 ET	514
Chevrolet 2007	10649 ET	515
Chevrolet 2007	10618 ET	516
Ford 1997	12515 ET	518
Ford 1998	12507 ET	519
Ford 1999	10658 ET	521
Ford 1996	10656 ET	523
Ford 1998	16778 ET	524
Ford 1995	10661 ET	520
Chevrolet 2008	12790 ET	528
Ford 1999	12508 ET	530
Ford 1999	12509 ET	531
Ford 1996	10650 ET	535
Ford 1999	10663 ET	536
Ford 1997	12501 ET	541
Ford 2003	10607 ET	546
Ford 2003	10608 ET	547
Ford 1999	10625 ET	549
Ford 1992	12664 ET	578
Ford 1994	12666 ET	579
Ford 1995	12668 ET	580
Ford 1997	16748 ET	583
Ford 1997	12662 ET	584
Chevrolet 2001	DRM 8076	Medic-16
Chevrolet 2010	FAF 1831	Medic-18
Chevrolet 2010	FAF 1832	Medic-19
Chevrolet 2010	FAF 1833	Medic-20
Chevrolet 2010	FAF 1834	Medic-21
Ford 1997	16756 ET	554

RESULT:	ADOPTED [UNANIMOUS]
MOVER:	Richard Zydel, Councilmember
SECONDER:	Patricia Jaworowicz, Councilmember
AYES:	Holtz, Jaworowicz, Swiatek, Rogowski, Zydel, Markel, Kaznowski



11. RESOLUTION 2011-277

Recognize Emergency Medical Services Week- May 15-21, 2011

Sponsored By: Markel, Rogowski, Swiatek, Holtz, Jaworowicz, Zydel, Kaznowski

WHEREAS, emergency medical services is a vital public service; and

WHEREAS, the members of emergency medical services teams are ready to provide lifesaving care to those in need 24 hours a day, seven days a week; and

WHEREAS, access to quality emergency care dramatically improves the survival and recovery rate of those who experience sudden illness or injury; and

WHEREAS, the emergency medical services system consists of emergency physicians, emergency nurses, emergency medical technicians, paramedics, firefighters, educators, administrators and others; and

WHEREAS, the members of emergency medical services teams, whether career or volunteer, engage in thousands of hours of specialized training and continuing education to enhance their lifesaving skills; and

WHEREAS, it is appropriate to recognize the value and the accomplishments of emergency medical services providers by designating Emergency Medical Services Week; NOW, THEREFORE, BE IT

RESOLVED, the Town of Cheektowaga recognizes and proclaims the week of May 15-21, 2011, Emergency Medical Services Week, with the theme, *EMS: Everyday Heroes*, and encourages the community to observe the recognition and good works of these valued community servants.

RESULT:	ADOPTED [UNANIMOUS]
MOVER:	Charles Markel, Councilmember
SECONDER:	James Rogowski, Councilmember
AYES:	Holtz, Jaworowicz, Swiatek, Rogowski, Zydel, Markel, Kaznowski



12. RESOLUTION 2011-278

Open Burning Permit/2997 Broadway Street

Sponsored By: Councilmember Zydel, Councilmember Markel

WHEREAS, pursuant to the Open Burning Law of the Town of Cheektowaga, the Fire Inspector reviews various applications for open fires and open burning and renders his recommendation concerning the fire safety and impact to the general public of such application, AND

WHEREAS, the Town Board, pursuant to the Open Burning Law of the Town of Cheektowaga, is designated the Approval Agency, AND

WHEREAS, since the Town Board is the Approval Agency, it must affirm, modify or reject any recommendations or permits submitted to it by the Town Fire Inspector, AND

WHEREAS, an application for a permit was submitted by the Chief Robert Najuch , Forks Fire District, to conduct a open fire on June 18, 2011, rain date of June 19, 2011 on the property located at 2997 Broadway Street, Cheektowaga, New York AND

WHEREAS, the applicant intends to burn small fires within this structure for training purposes. the owner of the property, Richard & Kristine Lapaglia, has provided a letter of permission and has obtained a building permit to removed the structure following the training evolutions., AND

WHEREAS, the Fire Inspector has received this application and finds the application to be in compliance with conditions and requirements of the Town of Cheektowaga Fire Prevention Code and the Open Burning Law. He requests the Town Board approve issuance of a permit, AND

WHEREAS, this Town Board has reviewed the application submitted by Chief Robert Najuch-Forks Fire District and the recommendations of the Fire Inspector, NOW, THEREFORE, BE IT

RESOLVED, that this Town Board, authorizes the Fire Inspector to issue such permit.

RESULT:	ADOPTED [UNANIMOUS]
MOVER:	Richard Zydel, Councilmember
SECONDER:	Charles Markel, Councilmember
AYES:	Holtz, Jaworowicz, Swiatek, Rogowski, Zydel, Markel, Kaznowski



13. RESOLUTION 2011-279

Establish Accounts for Consolidated Local Streets and Highway Improvement Program (Chips)

Sponsored By: Councilmember Swiatek, Supervisor Holtz

WHEREAS, in 1991, the state Legislature Restructured the Consolidated Local Street and Highway Improvement Program (CHIPS), creating a new payment mechanism for the capital project portion of the program, AND

WHEREAS, before the Town can avail itself of the CHIPS funding for capital project portion the Town must first spend the money and then seek reimbursement for CHIPS, AND

WHEREAS, a capital account must be established, moneys must be transferred into such account, and then money from such account will be spent, to be reimbursed later, NOW THEREFORE, BE IT

RESOLVED, and that the following accounts be and hereby are established:

CHIPS State Aid (Expense) #5714-5132-0002 - \$344,174.50

CHIPS State Aid (Revenue) #5714-5132-3089 - \$344,174.50

RESULT:	ADOPTED [UNANIMOUS]
MOVER:	Jeff Swiatek, Councilmember
SECONDER:	Mary Holtz, Supervisor
AYES:	Holtz, Jaworowicz, Swiatek, Rogowski, Zydel, Markel, Kaznowski



14. RESOLUTION 2011-280

NYSDEC Year 8 Annual Report

Sponsored By: Councilmember Kaznowski, Supervisor Holtz

WHEREAS, a SPDES General Permit for Stormwater Discharges from Municipal Separate Stormwater Sewer Systems (MS4's) was issued to the Town of Cheektowaga by the New York State Department of Environmental Conservation (NYSDEC), which permit requires the Town to conduct a Stormwater Management Program designed to reduce the discharge of pollutants from storm sewer systems, AND

WHEREAS, the Year 8 Annual Report of activities completed to achieve measurable goals is required to be submitted to the NYSDEC following the receipt of public comment not later than June 1, 2011, AND

WHEREAS, a draft Annual Report has been prepared by the Town Engineer and is available for review and comment in the Office of the Town Engineer, NOW, THEREFORE, BE IT

RESOLVED, that public comment on the subject Annual Report shall be received until May 27th, 2011 for inclusion in the final report to be filed with the NYSDEC, AND, BE IT FURTHER

RESOLVED, that the Supervisor is hereby authorized to execute the Municipal Compliance Certification Form for submission to the NYSDEC with the Year 8 Annual Report.

RESULT:	ADOPTED [UNANIMOUS]
MOVER:	Stanley Kaznowski, Councilmember
SECONDER:	Mary Holtz, Supervisor
AYES:	Holtz, Jaworowicz, Swiatek, Rogowski, Zydel, Markel, Kaznowski



15. RESOLUTION 2011-281

Authorize Supervisor to Sign Agreement with the Cheektowaga Economic Development Corporation

Sponsored By: Councilmember Swiatek, Supervisor Holtz

WHEREAS, the Town Board is committed to pursuing economic development activities in order to preserve existing jobs, create new employment opportunities for Town residents and increase the Town's property tax base, and

WHEREAS, in accordance with these goals, the Cheektowaga Economic Development Corporation was created for the purpose of assisting and encouraging new business development and growth in the Town, and

WHEREAS, use of Community Development Block Grant funds may be used for economic development activities, NOW, THEREFORE, BE IT

RESOLVED, that the Supervisor be and hereby is authorized to execute a subrecipient agreement with the Cheektowaga Economic Development Corporation authorizing the use and expenditure of Community Development Block Grant funds for the 2011-2012 Program Year.

RESULT:	ADOPTED [UNANIMOUS]
MOVER:	Jeff Swiatek, Councilmember
SECONDER:	Mary Holtz, Supervisor
AYES:	Holtz, Jaworowicz, Swiatek, Rogowski, Zydel, Markel, Kaznowski



16. RESOLUTION 2011-282

Authorize Supervisor to Execute Grant Application For Secure Our Schools Program

Sponsored By: Councilmember Jaworowicz, Councilmember Rogowski

WHEREAS, the Secure Our School grant program, sponsored through the United States Department of Justice, Office of Community Oriented Policing Services, provides grants to municipal police departments to improve school safety; and

WHEREAS, the Town of Cheektowaga Police Department is interested in working with local school districts to avail itself of funding under this program and enhance the safety of school children in the community; NOW, THEREFORE BE IT

RESOLVED, that Grantmakers Advantage, Inc. the Town's grants consultant, be and hereby is authorized and directed to complete the necessary application forms, etc. to be submitted for the purpose of securing this grant, and BE IT FURTHER

RESOLVED, that 100% of the required matching funds shall be available from participating school districts and BE IT FURTHER

RESOLVED, that the Supervisor or Deputy Supervisor be and hereby is authorized and directed to execute any and all documents pertaining to the application for and acquisition of said funding.

RESULT:	ADOPTED [UNANIMOUS]
MOVER:	Patricia Jaworowicz, Councilmember
SECONDER:	James Rogowski, Councilmember
AYES:	Holtz, Jaworowicz, Swiatek, Rogowski, Zydel, Markel, Kaznowski



17. RESOLUTION 2011-283

Authorize Supervisor to Execute Grant Application for “Buckle Up New York” (“BUNY”) Program

Sponsored By: Councilmember Jaworowicz, Councilmember Rogowski

WHEREAS, the New York State Department of Motor Vehicles Governor's Traffic Safety Committee has made National Highway Safety Administration funds available through the County of Erie for the 2011-2012 year to fund the Buckle Up New York Program (“BUNY”) in the approximate amount of \$11,988.00 to improve enforcement of seat belt use; and

WHEREAS, grant monies will be used to support overtime police patrols targeting motorists who fail to use seat belts; NOW, THEREFORE BE IT

RESOLVED, that the Cheektowaga Police Department be authorized and directed to complete the necessary application, forms, etc. to be submitted to the State of New York Governor's Traffic Safety Committee for the purpose of securing this grant; and BE IT FURTHER

RESOLVED, that the Supervisor be and hereby is authorized and directed to execute all documents pertaining to the application and acquisition of said funding.

RESULT:	ADOPTED [UNANIMOUS]
MOVER:	Patricia Jaworowicz, Councilmember
SECONDER:	James Rogowski, Councilmember
AYES:	Holtz, Jaworowicz, Swiatek, Rogowski, Zydel, Markel, Kaznowski



18. RESOLUTION 2011-284

Authorize Supervisor to Execute Grant Application for Selective Traffic Enforcement Program ("STEP")

Sponsored By: Councilmember Jaworowicz, Councilmember Rogowski

WHEREAS, the New York State Department of Motor Vehicles Governor's Traffic Safety Committee has made National Highway Safety Administration funds available through the County of Erie for the 2011-2012 year to fund a Selective Traffic Enforcement Program ("STEP") grant to aid aggressive driving enforcement; and

WHEREAS, the Town of Cheektowaga Police Department has applied for such funding in the sum of \$12,150.00 to conduct this program in the Town of Cheektowaga; NOW THEREFORE, BE IT

RESOLVED, that this Town Board hereby authorizes and directs the Cheektowaga Police Department to complete the necessary application form and other documentation necessary for the Town to obtain these funds; and BE IT FURTHER

RESOLVED, that the Supervisor be, and hereby is authorized and directed to execute all documents pertaining to the application and acquisition of said funding.

RESULT:	ADOPTED [UNANIMOUS]
MOVER:	Patricia Jaworowicz, Councilmember
SECONDER:	James Rogowski, Councilmember
AYES:	Holtz, Jaworowicz, Swiatek, Rogowski, Zydel, Markel, Kaznowski



19. RESOLUTION 2011-285

Approve Overnight Campout for Cub Scout Pack 618 in Stiglmeier Park

Sponsored By: Councilmember Zydel, Councilmember Rogowski

WHEREAS, Cub Scout Pack 618 has requested permission to conduct an overnight campout on Saturday, June 11, 2011 to Sunday, June 12, 2011, in John C. Stiglmeier Park, and

WHEREAS, Section 174-14 of the Code of the Town Of Cheektowaga states that "all parks shall be closed between the hours of sunset and sunrise the following morning and no person shall remain inside any parks during the hours when so closed...", NOW, THEREFORE, BE IT

RESOLVED, that this Town Board hereby permits a waiver of Section 174-14 of the Code of the Town Of Cheektowaga and that said waiver shall be extended to Cub Scout Pack 618 for the use of John C. Stiglmeier Park on June 11 - 12, 2011, and BE IT FURTHER

RESOLVED, that the Town Clerk be and hereby is directed to forward copies of this resolution to the Chief of Police and to the Director of the Facilities Department.

RESULT:	ADOPTED [UNANIMOUS]
MOVER:	Richard Zydel, Councilmember
SECONDER:	James Rogowski, Councilmember
AYES:	Holtz, Jaworowicz, Swiatek, Rogowski, Zydel, Markel, Kaznowski



20. RESOLUTION 2011-286

Special Events - Southline Little League

Sponsored By: Councilmember Rogowski, Councilmember Zydel

WHEREAS, by resolution dated May 1, 1995, this Town Board adopted a Special Events policy, which requires anyone wishing to hold a special event in the Town to file an application and supporting documentation, fees, etc. to the Town Clerk prior to the special event; and

WHEREAS, the South Line Little League has made application to hold its annual Parade on Monday, May 30, 2011, commencing at 9:30 A.M.; said parade route to start at the Garden Village Plaza, then down French Road to Towers Boulevard, then to North Seine Drive, and ending at the Southline Little League baseball diamonds; and

WHEREAS, this Board has reviewed the aforementioned application, which application has been approved by the Town Board on behalf of the Police Department, the Department of Youth and Recreation, and the Facilities Department, and has no objection to same; and

WHEREAS, due to the nature of the event, this Town Board hereby waives the following requirements:

1. Submittal of plan for sanitary facilities;
2. Submittal of site plan;
3. Requirement that application be made at least 60 days prior to the date of the special event;
4. Submittal of Security Plan;
5. Submittal of Fire Prevention/Emergency Services Plan;

NOW, THEREFORE, BE IT

RESOLVED, that this Town Board hereby approves the application of South Line Little League for the aforementioned Parade, to be held on Monday, May 30, 2011; and BE IT FURTHER

RESOLVED, that the Chief of Police be and hereby is directed to provide traffic safety and escort services for such parade and to ensure compliance with Section 1660(a)(6) of the Vehicle and Traffic Law.

RESULT:	ADOPTED [UNANIMOUS]
MOVER:	James Rogowski, Councilmember
SECONDER:	Richard Zydel, Councilmember
AYES:	Holtz, Jaworowicz, Swiatek, Rogowski, Zydel, Markel, Kaznowski



21. RESOLUTION 2011-287

Special Events - War of 1812 Parade

Sponsored By: Councilmember Zydel, Councilmember Rogowski

WHEREAS, by resolution dated May 1, 1995, this Town Board adopted a Special Events policy, which requires anyone wishing to hold a special event in the Town to file an application and supporting documentation, fees, etc. to the Town Clerk prior to the special event, and

WHEREAS, the War of 1812 Cemetery Board of Trustees and Cheektowaga Patriotic Commission have made application to hold a War of 1812 Cemetery/Flag Day parade and commemoration ceremony on Sunday, June 12, 2011 beginning at 11:30 A.M. as follows:

1. Parade will assemble at the corner of Aero Drive and Wehrle Drive, and proceed down Aero Drive to the War of 1812 Cemetery, where the ceremonies will be held.
 2. Commemoration and fireworks display at Cheektowaga Town Park in the evening.
- and

WHEREAS, this Board has reviewed the aforementioned application, which application has been approved by the Cheektowaga Police Department, Parks Department and Highway Department and has no objection to same, and

WHEREAS, due to the nature of the event, this Town Board hereby waives the following requirements:

1. Submittal of plan for sanitary facilities;
2. Submittal of site plan;
3. Submittal of Security Plan;
4. Submittal of Fire Prevention/Emergency Services Plan.

NOW, THEREFORE, BE IT

RESOLVED, that this Town Board hereby approves the aforementioned application of the War of 1812 Cemetery Board of Trustees and the Cheektowaga Patriotic Commission for the aforementioned parade and commemoration ceremony to be held on June 12, 2011, and BE IT FURTHER

RESOLVED, that the Chief of Police be and hereby is directed to provide traffic safety and escort services for such parade and to ensure compliance with Section 1660 (a)(6) of the Vehicle and Traffic Law.

RESULT:	ADOPTED [UNANIMOUS]
MOVER:	Richard Zydel, Councilmember
SECONDER:	James Rogowski, Councilmember
AYES:	Holtz, Jaworowicz, Swiatek, Rogowski, Zydel, Markel, Kaznowski



22. RESOLUTION 2011-288

Special Events - South Cheektowaga Baseball Picnic

Sponsored By: Councilmember Rogowski, Councilmember Zydel

WHEREAS, by resolution dated May 1, 1995, this Town Board adopted a Special Events policy, which requires anyone wishing to hold a special event in the Town to file an application and supporting documentation, fees, etc. to the Town Clerk prior to the special event, and

WHEREAS, South Cheektowaga Baseball Association has made application to hold its End of Season League Picnic in Stiglmeier Park on August 6, 2011, commencing at 9:00 A.M.; and

WHEREAS, this Board has reviewed the aforementioned application, which application has been approved by the Facilities Department, and has no objection to same, and

WHEREAS, due to the nature of the event, this Town Board hereby waives the following requirements:

1. Submittal of plan for sanitary facilities;
2. Submittal of site plan;
3. Submittal of Security Plan;
4. Submittal of Fire Prevention/Emergency Services Plan;

NOW, THEREFORE, BE IT

RESOLVED, that this Town Board hereby approves the aforementioned application of South Cheektowaga Baseball Association for the aforementioned League Picnic event to be held in Stiglmeier Park on August 6, 2011.

RESULT:	ADOPTED [UNANIMOUS]
MOVER:	James Rogowski, Councilmember
SECONDER:	Richard Zydel, Councilmember
AYES:	Holtz, Jaworowicz, Swiatek, Rogowski, Zydel, Markel, Kaznowski



23. RESOLUTION 2011-289

Special Events - Bike Ride for Missing Children

Sponsored By: Councilmember Rogowski, Councilmember Zydel

WHEREAS, by resolution dated May 1, 1995, this Town Board adopted a Special Events policy, which requires anyone wishing to hold a special event in the Town to file an application and supporting documentation, fees, etc. to the Town Clerk prior to the special event; and

WHEREAS, the National Center for Missing and Exploited Children has made application to conduct its Ride for Missing Children through the Town of Cheektowaga on Wednesday, May 25th, 2011, at the anticipated times of 11:32 a.m. - 1:15 p.m; said Ride to include the following streets: Genesee Street and Union Road; and

WHEREAS, this Board has reviewed the aforementioned application, which application has been approved by the Police Department, the Department of Youth and Recreation, Highway Department and the Facilities Department, and has no objection to same; and

WHEREAS, due to the nature of the event, this Town Board hereby waives the following requirements:

1. Submittal of plan for sanitary facilities;
2. Submittal of site plan;
3. Requirement that application be made at least 60 days prior to the date of the special event;
4. Submittal of Security Plan;
5. Submittal of Fire Prevention/Emergency Services Plan;

NOW, THEREFORE, BE IT

RESOLVED, that this Town Board hereby approves the application the National Center for Missing and Exploited Children for the aforementioned "Ride for Missing Children", to be held on Wednesday, May 25th, 2011; BE IT FURTHER

RESOLVED, that the Chief of Police be and hereby is directed to provide traffic safety and escort services for such ride and to ensure compliance with Section 1660(a)(6) of the Vehicle and Traffic Law.

RESULT:	ADOPTED [UNANIMOUS]
MOVER:	James Rogowski, Councilmember
SECONDER:	Richard Zydel, Councilmember
AYES:	Holtz, Jaworowicz, Swiatek, Rogowski, Zydel, Markel, Kaznowski



24. RESOLUTION 2011-290

Authorize Student Intern for Police Department (Platt)

Sponsored By: Councilmember Jaworowicz, Councilmember Rogowski

WHEREAS, Kyle Platt, a student at Medaille College, has requested to participate in the student internship program at the Cheektowaga Police Department, Crime Resistance Unit; AND

WHEREAS, Mr. Platt has been interviewed by the Police Department and the Department is willing to afford him the opportunity to intern in the Police Department; NOW, THEREFORE, BE IT

RESOLVED, that Kyle Platt of Buffalo, New York be and hereby is authorized to participate as an unpaid intern in the Cheektowaga Police Department Crime Resistance Unit, subject to his execution of a Waiver of Liability and Agreement of Confidentiality; AND BE IT FURTHER

RESOLVED, that the Supervisor be and hereby is authorized and directed to execute the Agreement of Confidentiality, and all other documents necessary to effectuate this student internship in the Police Department.

RESULT:	ADOPTED [UNANIMOUS]
MOVER:	Patricia Jaworowicz, Councilmember
SECONDER:	James Rogowski, Councilmember
AYES:	Holtz, Jaworowicz, Swiatek, Rogowski, Zydel, Markel, Kaznowski



25. RESOLUTION 2011-291

Creation of Four (4) Maintenance Worker and Four (4) Laborer Positions

Sponsored By: Councilmember Swiatek, Supervisor Holtz

BE IT RESOLVED, that this Town Board hereby creates four (4) Maintenance Worker and four (4) Laborer positions pursuant to Civil Service Laws and Rules effective April 19, 2011.

RESULT:	ADOPTED [UNANIMOUS]
MOVER:	Jeff Swiatek, Councilmember
SECONDER:	Mary Holtz, Supervisor
AYES:	Holtz, Jaworowicz, Swiatek, Rogowski, Zydel, Markel, Kaznowski



26. RESOLUTION 2011-292

Youth & Recreation Terminations

Sponsored By: Councilmember Zydel, Councilmember Rogowski

BE IT RESOLVED that the individuals listed below be and hereby are terminated in the Department of Youth & Recreational Services, effective as indicated:

Nathaniel Barnes	1/29/11	14225
Sarah Litwin	8/28/10	14225
Laura Munson	4/09/11	14043
Paul Parrinello	10/23/10	14086
Mary Zelasko	5/07/11	14227

Motion by Supervisor Holtz; Seconded by Councilmember Rogowski to waive the reading of names for the following four (4) resolutions: 2011-292 to 2011-295. Motion Carried.

RESULT: **ADOPTED [UNANIMOUS]**
MOVER: Richard Zydel, Councilmember
SECONDER: James Rogowski, Councilmember
AYES: Holtz, Jaworowicz, Swiatek, Rogowski, Zydel, Markel, Kaznowski



27. RESOLUTION 2011-293

Youth & Recreation Hiring

Sponsored By: Councilmember Zydel, Councilmember Rogowski

BE IT RESOLVED that the individuals listed below be and hereby are hired and/or transferred, as indicated, in the Department of Youth & Recreational Services, effective immediately:

Cheektowaga Conservation Corps (CCC)
Seasonal

Laborer - "Youth Leader" 7310.1811 - Seasonal

Laborer - "Level II" - \$9.40

Kyle Polanski 14043

Laborer - "Level IV" - \$9.90 - 7310.1811- Seasonal

Michael Lewandowski 14043

Laborer - "Crew Supervisor" - \$12.30 - 7310.1811

Laborer - "Level II" - Seasonal

Nicholas Russell 14206

Laborer - "Level III" - \$12.65 - 7310.1811- Seasonal

Brad Agen 14227

Laborer - "Level IV" - \$13.00 - 7310.1811- Seasonal

Jacob Bauer 14227

Laborer - "Level I Participant" - 7310.1816 - \$7.25

Michael Wrona 14225

Matthew Lanning 14225

Christopher Suchan 14227

Tyler Smith 14043

Timothy Baumgart 14225

Keith Kwiatkowski 14227

Zachary Uzar 14227

Laborer - "Level II Participant" - 7310.1816 - \$7.50

David Chwojdak 14227

Bradley Vargo 14225

Adam Skowron 14227

Daniel Zogaria 14206

Eric Nash 14206

Erin Rozewicz 14227

Laborer - "Level III Participant" - 7310.1816 - \$7.75

Jonathan Klein 14227

Joshua Galante 14206

Matthew Eckle 14225

Laborer - "Level III Participant" - 7310.1816 - \$8.00

Alissa Kowlaski	14206
Christopher Balash	14215

Laborer - "Level I Participant" - 7310.1816 - \$7.25 (Alternate)

Michael Tomczak	14227
Christopher Kelley	14215
Austin Baumgart	14225
Jordan Partyka	14043
Bryan Hastings	14043
Alan Craft	14225
Justen Dohn	14225
Joshua Swigonski	14227
Cody Berns	14225
Brandon Kruse	14206
Delorean Williamson	14225

Laborer "Level I Supervisor Trainee"- 7310.1816 - \$9.15 - Seasonal

Corey Patrzyk	14043
Andrew Samer	14227
Jamie Nash	14206

Laborer "Level II Supervisor Trainee"- 7310.1816 - \$9.40 - Seasonal

Edward Pyszczynski	14227
--------------------	-------

Laborer "Level III Supervisor Trainee"- 7310.1816 - \$9.65 - Seasonal

Justin DelBello	14227
-----------------	-------

Recreation Attendant - \$7.25 - 7140.1614, 7140.1645 & 7140.1648 - Regular Part-time

Tyler Welsh	14225
-------------	-------

Recreation Attendant - \$7.35 - 7140.1614, 7140.1645 & 7140.1648 - Regular Part-time

Valerie Herman	14225
----------------	-------

Recreation Instructor - 7140.1646 - \$9.00 - Regular Part-time

Michael Wojcicki	14043
------------------	-------

Recreation Attendant - \$7.50 - 7140.1614, 7140.1645 & 7140.1648 - Regular Part-time

Olivia Gmerek	14225
Cassandra Langan	14225

Recreation Attendant - 7140.1646 - \$7.50 - Seasonal

Spencer Calos	14227
Joshua Strzelec	14211
Alexis Wayne	14227

Recreation Attendant - 7140.1633 - \$8.00 - Regular Part-time

Reuben Owens	14225
--------------	-------

Recreation Aide - 7140.1614 - \$7.25 - Part-time

Audrelle Gospodarski	14225
----------------------	-------

Lifeguard - "Level IV" - \$8.76 - 7180.1903 - Seasonal

Jackie Campbell	14043
Andrew Charvat	14225
Nicholas Coronado	14225
Melissa Farruggio	14227
Jonathan Gworek	14227
Nicole Maciejewski	14227
Jacob Sauer	14227
Austin Snyder	14225
Katie Tomaschko	14225

Lifeguard - "Level III - WSI" - \$8.76 - 7180.1903 - Seasonal

Anastasia Zarbo	14227
-----------------	-------

Lifeguard - "Level III" - \$8.59 - 7180.1903 - Seasonal

Ken Carlucci	14227
Kayla Doetterl	14227
Kayla Kuechle	14225
Lauren Tomaschko	14225
Madalyn Lewis	14225

Lifeguard - "Level II" - \$8.42 - 7180.1903 - Seasonal

Catherine Chojnacki	14225
Matthew Hockwater	14227
Jennifer Weber	14225
Elizabeth Monaco	14225
Brandon Wheeler	14225
Brad Bauman	14227
Tyler Casillo	14227

Lifeguard - "Level I" - \$8.25 - 7180.1903 - Seasonal

Christopher Kiripolsky	14215
Michael Keller	14225

Lifeguard - "Level II" - \$8.42 - 7180.1903 - Regular Part-time

Dylan Bajer	14225
-------------	-------

Lifeguard - "Level I" - \$8.25 - 7180.1903 - Regular Part-time

Scott Ferer	14215
Dakota Grantham	14225
Elicia MacTarnaghan	14225
Adam McPherson	14225
Sharrieff Fareed-Muhammad	14215
Mindy Odrobina	14043
Katelin Petranchuk	14227

Lifeguard - "Level I with WSI" - \$8.42 - 7180.1903 - Regular Part-time

Nicole Odrobina	14043
-----------------	-------

Recreation Instructor "Supervisor Maryvale Pool"- 7180.1902 - \$9.86 Seasonal

Caitlin Rieck	14225
---------------	-------

Recreation Instructor "Supervisor Town Park Pool 2nd Shift"- 7180.1902 - \$10.36

Seasonal

Andrew Chruscicki 14225

Recreation Instructor "Head Lifeguard Town Park Pool 1st Shift"- 7180.1902 - \$9.36Seasonal

Danielle Malicki 14227

Recreation Instructor "Head Lifeguard Dingens Pool"- 7180.1902 - \$9.06Regular Part-time

Holly Podniesinski 14227

Recreation Instructor "Head Lifeguard Maryvale Pool"- 7180.1902 - \$9.06Seasonal

Naomi Snyder 14225

And WHEREAS the Youth & Recreational Services Department is in need of replacing its Day Camp Nurse and its Conservation Corps Education Coordinator, and

WHEREAS, multiple attempts to advertise and interview for these positions did not yield qualified candidates residing within the domiciliary of the Town of Cheektowaga, and

WHEREAS, Chapter 25-7 of the Town Code allows for the TOWN to relax residency restrictions for any position of employment requiring special skills, aptitude and expertise and

WHEREAS, both of the above positions require special skills, aptitude and expertise as per code 25-7, NOW, THEREFORE, BE IT

RESOLVED, that, based on the above, this Town Board hereby exempts the following two positions and individuals from Town residency requirement; and hereby appoints them to the following respective positions, effective immediately:

Recreation Instructor "Camp Nurse" - 7310.1810 - \$11.00 - Regular Part-Time

Denise Atkinson 14220

Recreation Specialist "CCC Education Coordinator" - 7310.1811 - \$14.50Regular Part-Time

Jonathan Townsend 14208

RESULT:	ADOPTED [UNANIMOUS]
MOVER:	Richard Zydel, Councilmember
SECONDER:	James Rogowski, Councilmember
AYES:	Holtz, Jaworowicz, Swiatek, Rogowski, Zydel, Markel, Kaznowski



28. RESOLUTION 2011-294

Youth & Recreation Transfers

Sponsored By: Councilmember Zydel, Councilmember Rogowski

BE IT RESOLVED that the individuals listed below be and hereby are hired and/or transferred, as indicated, in the Department of Youth & Recreational Services, effective immediately:

Recreation Specialist - 7310.1811 - \$18.55 - Regular Part-time
Roger Newhouse

Recreation Attendant - 7140.1646 - \$8.00 - Regular Part-time
Daniel Kruszynski

Recreation Attendant - 7140.1646 - \$8.40 - Regular Part-time
Danielle Smith

Recreation Attendant - 7140.1646 - \$8.25 - Regular Part-time
Steven Gasiorek

Recreation Attendant - 7140.1633 - \$8.40 - Regular Part-time
Amy Krytus

Recreation Attendant - 7140.1633 - \$8.75 - Regular Part-time
Gregory Craft

Recreation Attendant - 7140.1614 & 7140.1611 - \$7.35 - Regular Part-time
Adam Miller

Recreation Attendant - 7310.1804 - \$7.75 - Regular Part-time
Christine Jedd

From Recreation Aide to Recreation Attendant - \$7.25 - 7140.1614, 7140.1645 & 7140.1648 - Regular Part-time
Emily Bowen

Recreation Attendant - 7310.1804 - \$8.15 - Regular Part-time
Deanna Szymkowiak

Recreation Instructor "Aquatics Director/Special Events"- 7180.1902 - \$11.76
Regular Part - time (Effective 5/23/11)
Sean Kunkel

Recreation Instructor "Supervisor Town Park Pool 1st Shift"- 7180.1902 - \$10.56
Regular Part - time (Effective 5/23/11)
Jeffery Kunkel

Recreation Instructor "Supervisor Dingens Pool"- 7180.1902 - \$10.26

Regular Part - time (Effective 5/23/11)

Hannah Welch

Recreation Instructor "Head Lifeguard 2nd Shift Town Park Pool"- 7180.1902 - \$9.54 - Regular Part - time (Effective 5/23/11)

Rebecca Gworek

From Regular Part-time to Part-timeRecreation Instructor - 7180.1902 - \$9.24

Lauren Fuest

From Regular Part-time to Part-timeLifeguard "Level IV" - 7180.1903 - \$8.76

Tiffany Wheeler

Lifeguard - "Level IV" - 7180.1903 - \$8.76 - Regular Part - time (Effective 5/23/11)

Ashley Bajer

Raena Koeppel

Lifeguard - "Level III" - 7180.1903 - \$8.59 - Regular Part - time (Effective 5/23/11)

Margaret Drzewiecki

Nicole Scherrer

Chelsea Wartinger

Lifeguard - "Level II" - 7180.1903 - \$8.42 - Regular Part - time (Effective 5/23/11)

Tyler Bajer

Kari Orłowski

Keileigh Pecyne

Recreation Attendant - 7140.1614 - \$8.40 - Regular Part-time

Courtney Smith

Recreation Attendant - 7140.1642 - \$8.50 - Regular Part-time

Brian Mayle

From Adapted Recreation Program (ARP) - 7310.1803 to Camp Flamingo - 7310.1810Regular Part-time - Effective immediately

Jennifer Laffrado

Amanda Langa

Amy McMahon

Kristen Stadelmeyer

Lauren Sydlowski

From ARP - 7310.1803 to Camp Flamingo - 7310.1810Part-time - Effective immediately

Martin Acevedo

Kelly Mayer

Nicole Putland

From ARP - 7310.1803 to Camp Crabapple - 7310.1802Regular Part-time - Effective immediately

Meggan Empric

Bryan Haxton

DeYonca Porter

From ARP - 7310.1803 to Camp JI-IK-DO-WAH-GAH -7310.1801

Regular Part-time - Effective immediately

Alex Ladowski

Maribeth Stadelmeyer

Jessica Szyka

From ARP - 7310.1803 to Camp JI-IK-DO-WAH-GAH -7310.1801

Regular Part-time - Effective immediately - Recreation Specialist - \$11.25

Melissa Rogers

From ARP - 7310.1803 to Camp JI-IK-DO-WAH-GAH -7310.1801

Part-time - Effective immediately

Jenna Soldaczewski

From ARP - 7310.1803 to Teen Club - 7310.1814

Regular Part-time - Effective immediately

Casey Hawley

Jennifer Zelasko

RESULT:	ADOPTED [UNANIMOUS]
MOVER:	Richard Zydel, Councilmember
SECONDER:	James Rogowski, Councilmember
AYES:	Holtz, Jaworowicz, Swiatek, Rogowski, Zydel, Markel, Kaznowski



29. RESOLUTION 2011-295

Hiring/Termination of Part-Time/Seasonal Employees

Sponsored By: Councilmember Swiatek, Supervisor Holtz

BE IT RESOLVED, that the following individuals be and hereby are hired as **SEASONAL EMPLOYEES**, not to exceed five (5) months in a calendar year, in the various departments listed and in compliance with Civil Service Laws and Regulations as well as the provisions of the Town's collective bargaining agreement between the Town of Cheektowaga and the Town of Cheektowaga Employees Association:

SEWER MAINTENANCE Laborer \$8.00/hour effective 5/17/11
Nicholas B. Kotarski, Cheektowaga, New York

SEWER MAINTENANCE Laborer \$8.00/hour effective 5/17/11
Jacob M. Latshaw, Cheektowaga, New York

SEWER MAINTENANCE Laborer \$8.00/hour effective 5/17/11
Jacob A. Nowak, Cheektowaga, New York
Shane M. Latshaw, Cheektowaga, New York

SEWER MAINTENANCE Laborer \$8.00/hour effective 6/27/11
Sean F. Ross, Cheektowaga, New York

SANITATION DEPARTMENT Laborer \$8.00/hour effective 5/16/11
Thomas M. Buil, Depew, New York
Dean M. Mertowski, Cheektowaga, New York
Steven J. Krystyniak, Cheektowaga, New York
Kevin L. Adamczyk, Cheektowaga, New York
Justin J. Adamczyk, Cheektowaga, New York
Mark R. Zak, Cheektowaga, New York

BE IT RESOLVED, that the following individual be and hereby is transferred as follows:

FACILITIES DEPARTMENT (Parks Division) Part-Time Laborer to Seasonal Laborer \$11/hour effective 5/17/11
Thomas Somogye, Cheektowaga, New York

RESULT:	ADOPTED [UNANIMOUS]
MOVER:	Jeff Swiatek, Councilmember
SECONDER:	Mary Holtz, Supervisor
AYES:	Holtz, Jaworowicz, Swiatek, Rogowski, Zydel, Markel, Kaznowski



30. RESOLUTION 2011-296

Appointment of CEDC Directors

Sponsored By: Councilmember Swiatek, Supervisor Holtz

WHEREAS, the Town Board of the Town of Cheektowaga previously created the Cheektowaga Economic Development Corporation for the purpose of assisting and encouraging economic development within the Town, and

WHEREAS, By Resolution dated February 7, 1983 this Town Board approved the By-Laws of the Cheektowaga Economic Development Corporation which provide that the Directors of the Cheektowaga Economic Development Corporation be appointed by resolution of the Cheektowaga Town Board, and

WHEREAS, the Cheektowaga Economic Development Corporation has recommended the appointment of the individuals listed below to the Board of Directors of the Cheektowaga Economic Development Corporation, NOW, THEREFORE, BE IT

RESOLVED, that the following individuals are hereby appointed to the Board of Directors of the Cheektowaga Economic Development Corporation, effective immediately for a term of three years, said term expiring at the time of reappointment to said Board of Directors positions but no later than June 30, 2014:

James Antkowiak
 Stephen Bojdak
 Jack R. Patterson
 Richard Velez
 Patricia Cwiklinski
 Denis Serugendo

RESULT:	ADOPTED [UNANIMOUS]
MOVER:	Jeff Swiatek, Councilmember
SECONDER:	Mary Holtz, Supervisor
AYES:	Holtz, Jaworowicz, Swiatek, Rogowski, Zydel, Markel, Kaznowski



31. RESOLUTION 2011-297

Appointment of Detective (Police Department) James J. Genson

Sponsored By: Councilmember Jaworowicz, Councilmember Swiatek

WHEREAS, James J. Genson was assigned to the rank of Acting Detective in the Detective Bureau on November 8, 2010; AND

WHEREAS, the aforementioned employee has completed the Intern Program and satisfactorily served the six (6) month probationary period; NOW, THEREFORE, BE IT

RESOLVED, that James J. Genson of Cheektowaga, New York, be and hereby is assigned to the rank of Detective in the Police Department in accordance with the terms and conditions of the Town's collective bargaining agreement with the Town of Cheektowaga Police Club effective May 8, 2011.

RESULT:	ADOPTED [UNANIMOUS]
MOVER:	Patricia Jaworowicz, Councilmember
SECONDER:	Jeff Swiatek, Councilmember
AYES:	Holtz, Jaworowicz, Swiatek, Rogowski, Zydel, Markel, Kaznowski

**32. RESOLUTION 2011-298****Appointment of Outreach Worker- Senior Citizens
(Competitive/Permanent) Senior Services Department/Jamie
Acoff**

Sponsored By: Councilmember Swiatek, Supervisor Holtz

WHEREAS, this Town Board appointed Jamie Acoff to the provisional title of Outreach Worker - Senior Services in the Department of Senior Services on September 14, 2009; AND

WHEREAS, the Town has been notified that Erie County Civil Service has established a competitive list for said title; AND

WHEREAS, Ms. Acoff is eligible for permanent appointment from said list; NOW, THEREFORE, BE IT

RESOLVED, that Jamie Acoff of Cheektowaga, New York, be and hereby is appointed to the title of Outreach Worker - Senior Services in the Department of Senior Services in accordance with the terms and conditions of the Town's collective bargaining agreement with the Town of Cheektowaga Employees Association effective May 17, 2011.

RESULT:	ADOPTED [UNANIMOUS]
MOVER:	Jeff Swiatek, Councilmember
SECONDER:	Mary Holtz, Supervisor
AYES:	Holtz, Jaworowicz, Swiatek, Rogowski, Zydel, Markel, Kaznowski



33. RESOLUTION 2011-299

Appointment of Planner (Non-Competitive/Promotional) Building and Plumbing Department/Daniel J Ulatowski

Sponsored By: Councilmember Swiatek, Supervisor Holtz

WHEREAS, this Town Board created the title of Planner effective April 19, 2011; AND

WHEREAS, Zoning Inspector Daniel J. Ulatowski has been approved for a permanent non-competitive promotion by Erie County Personnel Commissioner John Greenan; NOW, THEREFORE, BE IT

RESOLVED, that Daniel J. Ulatowski of East Amherst, New York, be and hereby is appointed to the position of Planner in the Building and Plumbing Department in accordance with the terms and conditions of the Town's collective bargaining agreement with the Town of Cheektowaga Employees Association effective May 17, 2011.

RESULT:	ADOPTED [UNANIMOUS]
MOVER:	Jeff Swiatek, Councilmember
SECONDER:	Mary Holtz, Supervisor
AYES:	Holtz, Jaworowicz, Swiatek, Rogowski, Zydel, Markel, Kaznowski



34. RESOLUTION 2011-300

Travel Authorization Police Department/Detective Mark Jedd

Sponsored By: Councilmember Jaworowicz, Councilmember Swiatek

WHEREAS, the "North East International Association of Auto Theft Investigators 2011 Joint Annual Training Seminar" is being held August 14 through August 19, 2011 in Atlantic City, New Jersey; AND

WHEREAS, Detective Mark Jedd has requested authorization to attend said seminar; AND

WHEREAS, Police Chief David Zack has submitted a request for travel authorization along with the proper paperwork in a timely manner; AND

WHEREAS, the total cost to the Town shall not exceed \$1,410.81; AND

WHEREAS, these expenses have been budgeted by the Police Department; NOW, THEREFORE, BE IT

RESOLVED, that Detective Mark Jedd be and hereby is authorized to attend the "North East International Association of Auto Theft Investigators 2011 Joint Annual Training Seminar" being held August 14 through August 19, 2011 in Atlantic City, New Jersey.

RESULT:	ADOPTED [UNANIMOUS]
MOVER:	Patricia Jaworowicz, Councilmember
SECONDER:	Jeff Swiatek, Councilmember
AYES:	Holtz, Jaworowicz, Swiatek, Rogowski, Zydel, Markel, Kaznowski

V. Suspension of Rules

Motion by Councilmember Rogowski; Seconded by Supervisor Holtz; to suspend the rules to Include the following three (3) resolutions: 2011-301; 2011-302; 2011-303. Motion Carried.
--



1. RESOLUTION 2011-301

Authorize Supervisor to Sign Agreement

Sponsored By: Councilmember Jaworowicz, Councilmember Rogowski

WHEREAS, The court system provides language and sign interpreters in proceedings for persons of Limited English Proficiency and those who are deaf or hard of hearing. In all proceedings parties are provided with interpreters to ensure that they clearly comprehend and are able to participate in legal proceedings; AND

WHEREAS, The New York State Unified Court System (UCS) is committed to ensuring that legal proceedings conducted in New York's courts and court agencies are equally accessible to all persons regardless of an individual's ability to communicate effectively in the spoken English language. Court interpreters serve a fundamental role, the Unified Court System has given a high priority to the development and implementation of selection procedures to ensure that court interpreters have the necessary language proficiency to perform their duties competently and professionally; AND

WHEREAS, the Justice Court will contract with individuals on a per diem basis, as needed, to provide interpreting services ("per diem" court interpreters). Per diem interpreters are not employees of the court system; they are hired for the day and paid a per diem rate. A voucher is submitted with supporting documentation in order for per diem interpreters to receive payment; AND

WHEREAS, the 8th Judicial District maintains a registry of individuals who have successfully completed a written English proficiency screening certification examination and an oral assessment in English and the other languages. The languages for which the court system provides proficiency examinations are:

Albanian,	Greek	Polish	Mandarin
Arabic	Haitian	Creole	Russian
Bengali	Italian	French	Spanish
Cantonese	Korean	Portuguese	Vietnamese

The court system uses this registry as a primary resource for selecting per diem court interpreters in those languages; AND

WHEREAS, by virtue of lack of available "per diem" court interpreters in particular foreign languages, the justice court seeks to create a customer profile with an "over-the-phone" interpretation service provider; AND

WHEREAS, the pricing is based on New York State OGS pricing, Contract PS63093 from, funding has been allocated from budget line #100-1110-4592 for said services, AND

NOW, THEREFORE, BE IT RESOLVED that the Supervisor is authorized to execute all Agreement(s) with Language Line Services for the above services that may be required by the Justice Court, all subject to approval of same by the Town Attorney's Office

Language Line Services, Inc.
1 Lower Ragsdale Drive, Bldg 2
Monterey, CA 93940

RESULT:	ADOPTED [UNANIMOUS]
MOVER:	Patricia Jaworowicz, Councilmember
SECONDER:	James Rogowski, Councilmember
AYES:	Holtz, Jaworowicz, Swiatek, Rogowski, Zydel, Markel, Kaznowski



2. RESOLUTION 2011-302

Approve Purchase of X-Ray Inspection System

Sponsored By: Councilmember Jaworowicz, Councilmember Rogowski

WHEREAS, the Cheektowaga Justice Court, has applied to the New York State Unified Court System, Justice Court Assistance Program to seek grant monies to enhance the courthouse security plans and operation of the Court by including the purchase and installation of an X-Ray machine; AND

WHEREAS, the Justice Court has received a grant award under the 2010 cycle of the Justice Court Assistance Program; AND

WHEREAS, the 2010 (JCAP) award has provided the Justice Court with the resources to purchase the essential standard security equipment for the public entrance, to fulfill the Justice Court's critical role in our justice system, a HI-SCAN 6040ds X-Ray Inspection System, inclusive of installation and training, based on New York State OGS pricing, Contract # PC620007, and a 24 month warranty; AND

WHEREAS, the 2010 (JCAP) award has also provided the Justice Court with the resources to purchase crowd control dual belt Tensabarriers; AND

WHEREAS, funding has been allocated from budget line #100-1110-2105 for said purchase, AND NOW, THEREFORE, BE IT

RESOLVED, that the Town Board hereby authorizes the purchase of the 6040ds X-Ray Inspection System in the amount of \$25,855.00 from:

Smiths Detection Inc.
60 A. Columbia Road
Morristown, NJ 07960

RESULT:	ADOPTED [UNANIMOUS]
MOVER:	Patricia Jaworowicz, Councilmember
SECONDER:	James Rogowski, Councilmember
AYES:	Holtz, Jaworowicz, Swiatek, Rogowski, Zydel, Markel, Kaznowski



3. RESOLUTION 2011-303

Application for NYS Affordable Housing Corporation Funding

Sponsored By: Councilmember Markel, Councilmember Kaznowski

WHEREAS, the New York State Affordable Housing Corporation is accepting applications for grant funding for home improvements programs, and

WHEREAS, said funds can be used in conjunction with Community Development Block Grant and HOME Investment Partnership funds to accomplish needed rehabilitation for low-to-moderate income homeowners, and

WHEREAS, the Town Community Development Office has prepared an application for submission to the State Affordable Housing Corporation for said funds, NOW, THEREFORE, BE IT

RESOLVED, that the Supervisor be and hereby is authorized to sign said application, and any related documents, and submit same to the New York State Affordable Housing Corporation for a grant of up to \$300,000 for "home improvements" for low-to-moderate income Town homeowners under the Affordable Home Ownership Development Program, as authorized by Section 1113(1) of the Private Housing Finance Law, and Be It

FURTHER RESOLVED, that a copy of this resolution be forwarded to State Assemblyman Dennis Gabryszak and State Senator Timothy Kennedy.

RESULT:	ADOPTED [UNANIMOUS]
MOVER:	Charles Markel, Councilmember
SECONDER:	Stanley Kaznowski, Councilmember
AYES:	Holtz, Jaworowicz, Swiatek, Rogowski, Zydel, Markel, Kaznowski

VI. Communications

A. Departmental Communications

1. Minutes: Cheektowaga Planning Board - April 14, 2011
2. Minutes: Town Environmental Advisory Committee - April 27, 2011
3. Minutes: Cheektowaga Public Library - Board of Trustees - April 20, 2011

B. General Communications

1. Summons & Complaint: Cynthia E. Hess Vs. Town of Cheektowaga & Etal
2. Notice of Claim: Martin E. Davis Vs. Town of Cheektowaga
3. Notice of Claim: Nicholas Mogavero Vs. Town of Cheektowaga

VII. Comments

A. Supervisor's Comments

B. Councilmember's Comments

C. Public Comments

VIII. Adjournment

Motion by Supervisor Holtz; Seconded by Councilmember Kaznowski to adjourn the meeting in Memory of Retired Patrolman, Walter Bobeck,.



Town of Cheektowaga

Work Session

~ Minutes ~

3301 Broadway
Cheektowaga, NY 14227

<http://www.town.cheektowaga.ny.us>

Alice Magierski
716-686-3400

Tuesday, May, 31, 2011

6:00 PM

Council Office

I. Call to Order

6:00 PM Meeting called to order on May 31, 2011 at Council Office, Conference Room, Cheektowaga, NY.

Attendee Name	Organization	Title	Status	Arrived
Mary Holtz	Town of Cheektowaga	Supervisor	Present	
Patricia Jaworowicz	Town of Cheektowaga	Councilmember	Present	
Jeff Swiatek	Town of Cheektowaga	Councilmember	Late	6:13 PM
James Rogowski	Town of Cheektowaga	Councilmember	Absent	
Richard Zydel	Town of Cheektowaga	Councilmember	Present	
Charles Markel	Town of Cheektowaga	Councilmember	Present	
Stanley Kaznowski	Town of Cheektowaga	Councilmember	Present	

2. Additional Attendees

Brian Krause, Director of Finance and Administration
Anthony Romano, Coordinator of Employee Relations
Kevin Schenk, Town Attorney

II. Resolutions



1. RESOLUTION 2011-304

Accept Sanitary Sewer Easement - 3993 Union Road

Sponsored By: Councilmember Kaznowski, Councilmember Zydel

WHEREAS, the Town of Cheektowaga Engineering Department is working on a sanitary sewer project in the North Creek/South Creek Drive area of the Town, and

WHEREAS, DDR MDT Union Consumer Square LLC owns a portion of property through which the Town needs to install a sanitary sewer line for this project, and

WHEREAS, DDR MDT Union Consumer Square LLC has consented to grant the Town of Cheektowaga the necessary sanitary sewer easement through its property, NOW, THEREFORE, BE IT

RESOLVED, that this Town Board hereby accepts said sanitary sewer easement, and BE IT FURTHER

RESOLVED, that the Town Supervisor be and hereby is authorized and directed to execute this easement agreement in behalf of the Town of Cheektowaga, and BE IT FURTHER

RESOLVED, that the Town Attorney be and hereby is directed to file said easement in the Erie County Clerk's Office.

RESULT:	ADOPTED [UNANIMOUS]
MOVER:	Stanley Kaznowski, Councilmember
SECONDER:	Richard Zydel, Councilmember
AYES:	Holtz, Jaworowicz, Swiatek, Zydel, Markel, Kaznowski
ABSENT:	James Rogowski



2. RESOLUTION 2011-305

Special Event - Cheektowaga Southside Little League

Sponsored By: Supervisor Holtz, Councilmember Markel

WHEREAS, by resolution dated May 1, 1995, this Town Board adopted a Special Events policy, which requires anyone wishing to hold a special event in the Town to file an application and supporting documentation, fees, etc. to the Town Clerk prior to the special event; and

WHEREAS, the Cheektowaga Southside Little League has made application to hold its Annual Baseball Parade on Saturday, June 4, 2011, beginning at 12:00 noon, said parade to begin on William Street from Doyle Fire Hall, left onto Standard Parkway, right onto Wojcik Street into Cheektowaga Southside diamonds, and

WHEREAS, this Board has reviewed the aforementioned application, which application has been approved by the Police Department, the Department of Youth and Recreation, and the and Facilities Department, and has no objection to same; and

WHEREAS, due to the nature of the event, this Town Board hereby waives the following requirements:

1. Submittal of plan for sanitary facilities;
2. Submittal of site plan;
3. Requirement that application be made at least 60 days prior to the date of the special event;
4. Submittal of Security Plan;
5. Submittal of Fire Prevention/Emergency Services Plan;

NOW, THEREFORE, BE IT

RESOLVED, that contingent upon approval from the necessary Town department (s), this Town Board hereby approves the application of Cheektowaga Southside Little League for the aforementioned Parade, to be held on Saturday, June 4, 2011 at 12:00 noon; BE IT FURTHER

RESOLVED, that the Chief of Police be and hereby is directed to provide traffic safety and escort services for such parade and to ensure compliance with Section 1660(a)(6) of the Vehicle and Traffic Law.

RESULT:	ADOPTED [UNANIMOUS]
MOVER:	Mary Holtz, Supervisor
SECONDER:	Charles Markel, Councilmember
AYES:	Holtz, Jaworowicz, Swiatek, Zydel, Markel, Kaznowski
ABSENT:	James Rogowski

III. Adjournment

Time of adjournment was 6:30 PM

Alice Magierski, Town Clerk



Town of Cheektowaga

Regular Meeting

~ Minutes ~

3301 Broadway
Cheektowaga, NY 14227

<http://www.town.cheektowaga.ny.us>

Alice Magierski
716-686-3400

Monday, June, 6, 2011

6:45 PM

Council Chambers

I. Call to Order

6:45 PM Meeting called to order on June 6, 2011 at Council Chambers, 3301 Broadway St, Cheektowaga, NY.

Attendee Name	Organization	Title	Status	Arrived
Mary Holtz	Town of Cheektowaga	Supervisor	Present	
Patricia Jaworowicz	Town of Cheektowaga	Councilmember	Present	
Jeff Swiatek	Town of Cheektowaga	Councilmember	Present	
James Rogowski	Town of Cheektowaga	Councilmember	Present	
Richard Zydel	Town of Cheektowaga	Councilmember	Present	
Charles Markel	Town of Cheektowaga	Councilmember	Present	
Stanley Kaznowski	Town of Cheektowaga	Councilmember	Present	

2. Additional Attendees

Thomas Adamczak, Supervising Building and Plumbing Inspector
Ellen Fischer, Executive Director - Youth Board
Jerry Gabryszak, Director of Community Development
John Marriott, Planning Board Chairman
William Pugh, Town Engineer
Kevin Schenk, Town Attorney
David Zack, Chief of Police

II. Public Comment Period

III. Resolutions



1. RESOLUTION 2011-306

Transfer of Funds

Sponsored By: Supervisor Holtz, Councilmember Swiatek

BE IT RESOLVED, that the following transfer is hereby approved and made a part hereof;

GENERAL FUND

FROM:	100.3020.1902	Overtime Payroll	\$ 5,000.00
	100.1440.4042	Maps	1,500.00
	100.7550.2041	Special Event Revenues	1,500.00
	100.1910.2680	Insurance Recoveries	589.83
TO:	100.3020.1971	Part Time Payroll	\$ 5,000.00
	100.1440.4001	Office Supplies	1,500.00
	100.7110.1902	Facilities Overtime	1,500.00
	100.1640.4447	Collision Repairs	589.83

SPECIAL DISTRICTS FUND

FROM:	255.8125.9201	Bond Interest	\$ 15,000.00
TO:	255.8125.2550	Vehicles	\$ 15,000.00

HIGHWAY FUND

FROM:	300.5141.1951	Seasonal Wages	\$ 28,000.00
	300.5140.4188	Rental of Copier	2,200.00
	300.9501.9211	Bond Interest	26,500.00
TO:	300.5141.1902	Overtime Payroll	\$ 27,000.00
	300.5141.1914	Shift Differential	1,000.00
	300.5142.4029	Salt	2,200.00
	300.5130.4462	Parts & Supplies	26,500.00

HUD CDBG FUND

FROM:	700.1010.0602	Demolition	\$ 10,000.00
	700.1010.2200	Acquisition	5,000.00
	700.1010.0706	Housing Counseling	1,500.00
TO:	700.1010.0603	Environmental Testing	\$ 10,000.00
	700.1010.0703	Administration	5,000.00
	700.1010.0703	Administration	1,500.00

PART TOWN FUND

FROM:	800.3620.1902	Overtime Payroll	\$ 8,000.00
TO:	800.1910.2799	Appropriated Fund Balance	\$ 8,000.00

RESULT:	ADOPTED [UNANIMOUS]
----------------	----------------------------

MOVER: Mary Holtz, Supervisor
SECONDER: Jeff Swiatek, Councilmember
AYES: Holtz, Jaworowicz, Swiatek, Rogowski, Zydel, Markel, Kaznowski



2. RESOLUTION 2011-307

Warrant

Sponsored By: Supervisor Holtz, Councilmember Swiatek

BE IT RESOLVED, that the following Vouchers & Warrants submitted to the Town of Cheektowaga prior to June 3, 2011 are hereby approved and made a part hereof;

GENERAL FUND	\$	587,530.50
RISK RETENTION FUND		25,490.38
HUD HOUSING REHABILITATION		880.00
SPECIAL DISTRICTS FUND		539,270.34
HIGHWAY FUND		185,988.05
CAPITAL FUND		543,158.65
TRUST & AGENCY FUND		8,248.69
HUD CDBG FUND		17,715.64
PART TOWN FUND		7,550.20
		<u>7,550.20</u>
	\$	1,915,832.45

RESULT:	ADOPTED [UNANIMOUS]
MOVER:	Mary Holtz, Supervisor
SECONDER:	Jeff Swiatek, Councilmember
AYES:	Holtz, Jaworowicz, Swiatek, Rogowski, Zydel, Markel, Kaznowski



3. RESOLUTION 2011-308

Call for Public Hearing - Rezoning Request 2480 and Part of 2490-2550 Walden Avenue

Sponsored By: Councilmember Markel, Councilmember Rogowski

WHEREAS, Benderson Development Company, LLC has made application and requested the rezoning of 2480 and Part of 2490-2550 Walden Avenue from M1- Light Manufacturing to CM- General Commercial for the re-development of an existing commercial site, including the demolition of an existing 122,500 square foot retail building and two other retail buildings comprising 62,000 square feet in area; and the construction of a 185,000 square foot retail building, NOW, THEREFORE BE IT

RESOLVED, that a Public Hearing be held regarding said request under the provisions of the Zoning Law on June 20, 2011 at 6:45 P.M., at the Cheektowaga Town Hall, 3301 Broadway at the corner of Union Road.

Notice of Public Hearing

NOTICE IS HEREBY GIVEN that a Public Hearing will be held by the Town Board of the Town of Cheektowaga, Erie County, New York at the Town Hall in the said Town of Cheektowaga, 3301 Broadway corner of Union Road on the 20th day of June, 2011 at 6:45 o'clock P.M., of said day for the purpose of considering the application of:

Benderson Development Company, LLC

for the rezoning of 2480 and Part of 2490-2550 Walden Avenue from M1- Light Manufacturing to CM- General Commercial for the re-development of an existing commercial site, including the demolition of an existing 122,500 square foot retail building and two other retail buildings comprising 62,000 square feet in area; and the construction of a 185,000 square foot retail building.

All parties in interest and citizens will be given an opportunity to be heard in regard to such proposed application.

BY ORDER OF THE TOWN BOARD, Town of Cheektowaga, NY

Alice Magierski, TOWN CLERK

LEGAL DESCRIPTION

ALL THAT TRACT OR PARCEL OF LAND, situate in the Town of Cheektowaga, County of Erie and State of New York, being part of Lot No. 11, Township 11 and Range 7 of the Holland Land Company's Survey and being further bounded and described as follows:

BEGINNING at a point in the east line of Lot No. 11 distant 140 feet south of its intersection with the south line of Zoerb Avenue as laid out on a map filed in the Erie County Clerk's office under

Map Cover No. 2146; (1) thence southerly along the east line of Lot No. 11, 244.56 feet to the northeast corner of lands conveyed to Lettice J. Lewis by deed recorded in the Erie County Clerk's Office in Liber 262 of Deeds at page 210; (2) thence westerly at right angles to the east line of Lot No. 11 and along the north line of lands so conveyed to Lettice J. Lewis 561 feet to the northwest corner of Lettice J. Lewis' lands; (3) thence southerly along the west line of lands so conveyed to Lettice J. Lewis 151.33 feet to the northeasterly corner of lands conveyed to Johnson, Drake and Piper, Inc. by deed dated July 20, 1956 and recorded in the Erie County Clerk's Office September 17, 1956 in Liber 6057 of Deeds at page 135; (4) thence westerly at right angles to the west line of lands so conveyed to Lettice J. Lewis and along the north line of lands conveyed to Johnson, Drake and Piper, Inc. 197.32 feet to the northwest corner of said last mentioned lands; (5) thence southerly parallel with the west line of lands so conveyed to Lettice J. Lewis and along the westerly line of lands so conveyed to Johnson, Drake and Piper, Inc. 457.84 feet to the north line of Walden Avenue (120 feet wide); (6) thence westerly along the north line of Walden Avenue 836.49 feet to its intersection with the west line of lands conveyed to Nathan Rovner by deed recorded in the Erie County Clerk's Office in Liber 5897 of Deeds at page 528; (7) thence north along the west line of land so conveyed to Nathan Rovner 986.51 feet to a point 140 feet southerly from the intersection of the said west line of Rovner's land with the south line of Zoerb Avenue as laid out on a map filed in the Erie County Clerk's office under Map Cover No. 2146; (8) thence easterly, parallel with the south line of Zoerb Avenue extended easterly 1584.91 feet to the point or place of beginning.

This parcel containing 973,523 Sq.Ft. or 22.349 acres more or less.

RESULT:	ADOPTED [UNANIMOUS]
MOVER:	Charles Markel, Councilmember
SECONDER:	James Rogowski, Councilmember
AYES:	Holtz, Jaworowicz, Swiatek, Rogowski, Zydel, Markel, Kaznowski



4. RESOLUTION 2011-309

Award of Bid - One (1) New and Unused Water Way Maintenance and Rescue Vehicle

Sponsored By: Councilmember Swiatek, Supervisor Holtz

WHEREAS, bids were received and opened by the Town Clerk at a public bid opening held on June 1, 2011, for One (1) New and Unused 2011 Water Way Maintenance and Rescue Vehicle for use by the Town of Cheektowaga Highway Department as a result of advertisement thereof, and such bid was referred to the Superintendent of Highway for analysis, tabulation and reports, AND

WHEREAS, bids were analyzed and completed, NOW THEREFORE BE IT

RESOLVED, the responsible bidder meeting bid specs for One (1) New and Unused 2011 Water Way Maintenance and Rescue Vehicle be awarded to Cyncon Equipment Inc., 7494 West Henrietta Road, Rush, New York 14543 at a total bid price of \$69,992.00 said bidder meeting specifications of bid. AND BE IT FURTHER

RESOLVED, that monies be charged to line item 300-1530-2407.

TABULATION FOR ONE (1) NEW AND UNUSED 2011 WATER WAY MAINTENANCE AND RESCUE VEHICLE

Neoteric Hovercraft Inc. 1649 Tippecanoe Street Terre haute, IN 47807-2394	\$69,960.00
--	-------------

Cyncon Equipment Inc. 7494 West Henrietta Road Rush, NY 14543	\$69,992.00
---	-------------

RESULT:	ADOPTED [UNANIMOUS]
MOVER:	Jeff Swiatek, Councilmember
SECONDER:	Mary Holtz, Supervisor
AYES:	Holtz, Jaworowicz, Swiatek, Rogowski, Zydel, Markel, Kaznowski



5. RESOLUTION 2011-310

Award of Bid - Sanitary Sewer Pipe

Sponsored By: Councilmember Kaznowski, Councilmember Zydel

WHEREAS, as a result of advertisement, bids were received on June 1, 2011 for the furnishing of SDR-35 Sanitary Sewer Pipe for the Cheektowaga Engineering Department, AND

WHEREAS, said bids were referred to the Town Engineer for analysis and tabulation, NOW, THEREFORE, BE IT

RESOLVED, that the contract for the furnishing of SDR-35 Sanitary Sewer Pipe be awarded to:

Vellano Brothers, Inc.
10 Lancaster Parkway
Lancaster, New York 14086

for submission of the lowest bid meeting the requirements of the specifications in the amount of \$25.84/ lin. ft., AND, BE IT FURTHER

RESOLVED, that funds have been budgeted in Account No. 500-1440-4542-5128 for this purchase.

RESULT:	ADOPTED [UNANIMOUS]
MOVER:	Stanley Kaznowski, Councilmember
SECONDER:	Richard Zydel, Councilmember
AYES:	Holtz, Jaworowicz, Swiatek, Rogowski, Zydel, Markel, Kaznowski



6. RESOLUTION 2011-311

Award Summer Camp Busing 2011

Sponsored By: Councilmember Zydel, Councilmember Rogowski

WHEREAS, in accordance with the policies and procedures adopted by the Cheektowaga Town Board for the procurement of goods and services, the Department of Youth and Recreational Services solicited proposals for transportation for its 2011 summer camp programs, AND

WHEREAS, proposals were received for the provision of said bus transportation services, AND

WHEREAS, First Student has submitted the lowest responsible quotation for the provision of bus transportation services, NOW, THEREFORE, BE IT

RESOLVED that this Town Board hereby awards the contract for the provision of bus transportation at a cost of \$9,700.00 for the Department of Youth & Recreational Services' day camp programs to:

--First Student
45 Anderson Road
Buffalo, New York 14225

Line Item Nos.: 7140.4517
7140.4518
7310.4691

RESULT:	ADOPTED [UNANIMOUS]
MOVER:	Richard Zydel, Councilmember
SECONDER:	James Rogowski, Councilmember
AYES:	Holtz, Jaworowicz, Swiatek, Rogowski, Zydel, Markel, Kaznowski



7. RESOLUTION 2011-312

Amend Use of HOME Program Funds

Sponsored By: Councilmember Markel, Councilmember Kaznowski

WHEREAS, the Town of Cheektowaga has received Home Investment Partnership funds through the Amherst HOME Consortium, of which the Town is a member, and

WHEREAS, the Town desires to amend its use of said HOME funds pursuant to the attached Community Development Block Grant Program and HOME Program Amendment Report, and

WHEREAS, citizens and interested parties were provided the opportunity to comment on the proposed amendment pursuant to the Citizen Participation Plan previously adopted by the Town Board, and

WHEREAS, the Director of Community Development recommends approval of the proposed amendment, Now Therefore Be It

RESOLVED, that the Town Board hereby amends its use of HOME Investment Partnership funds and requests the Town of Amherst, as Consortium Lead Community, to amend its Final Statement/Annual Plan on the Use of Community Development and HOME Investment Partnership Funds pursuant to the HOME Program Amendment Report.

Attachments:

2011 Amendment #1HOME Program-Amendment Report(DOC)

RESULT:	ADOPTED [UNANIMOUS]
MOVER:	Charles Markel, Councilmember
SECONDER:	Stanley Kaznowski, Councilmember
AYES:	Holtz, Jaworowicz, Swiatek, Rogowski, Zydel, Markel, Kaznowski



8. RESOLUTION 2011-313

Support for CDBG Funding

Sponsored By: Holtz, Markel, Kaznowski, Rogowski, Swiatek, Jaworowicz, Zydel

Whereas, the Town of Cheektowaga annually receives Community Development Block Grant funding from the U.S. Department of Housing and Urban Development, and

Whereas, Community Development Block Grant funds have enabled the Town to address infrastructure needs in aging, lower income neighborhoods and provide economic opportunities to area residents by assisting local businesses that are creating new jobs, and

Whereas, Community Development Block Grant funds have been a critical resource in the Town's efforts to revitalize and maintain viable and safe neighborhoods, combat housing blight, maintain and improve the quality of its housing stock and improve the quality of life for Town residents, particularly those in lower-moderate income neighborhoods, and

Whereas, over the life of the Community Development Block Grant program, the Town has been able to rehabilitate over 1,000 housing units, thereby helping to ensure a supply of affordable, safe and decent housing for future generations, while providing economic opportunities for small, locally owned contractors, and

Whereas, Community Development Block Grant funds have also been used to enhance the safety of its residents through neighborhood police foot patrols, assist the Town's and its Villages' increasing elderly population with needed outreach counseling and transportation services, provide pre-purchase counseling for first-time homebuyers and reduce home energy costs for lower income tenants and homeowners through weatherization services, and

Whereas, a significant reduction in Community Development Block Grant funding will seriously and adversely impact the Town's ability to address the problems it is experiencing as a first-ring suburban community, Now Therefore Be It

Resolved, that the Town Board hereby memorializes the President and Congress of the United States to maintain full funding for the Community Development Block Grant program in fiscal year 2012 in order to maintain the viability of this program which provides critical resources to communities throughout the United States, and Be It Further

Resolved, that a copy of this resolution be forwarded to Representative Brian Higgins, New York State Senators Charles Schumer and Kirsten Gillibrand, and Representatives Tom Latham, Chairperson of the House Subcommittee on Transportation-HUD and Representative John Olver, Ranking Member of said House Subcommittee.

RESULT:	ADOPTED [UNANIMOUS]
MOVER:	Mary Holtz, Supervisor
SECONDER:	Charles Markel, Councilmember
AYES:	Holtz, Jaworowicz, Swiatek, Rogowski, Zydel, Markel, Kaznowski



9. RESOLUTION 2011-314

Approve Auction of Town Surplus Vehicles and Equipment

Sponsored By: Councilmember Swiatek, Supervisor Holtz

WHEREAS, the Town wishes to dispose of a number of surplus motor vehicles and equipment no longer needed for Town use: and

WHEREAS, sale of surplus property by the Town is authorized by Section 64 of the Town law of the State of New York: and

RESOLVED, that the Town hereby retains Auctions International, Inc., 808 Borden Road, Cheektowaga, New York, as per the submitted contract, to conduct a sale of the surplus Town vehicles and equipment identified on the attached list at an on-line auction to be held on its website: and BE IT FURTHER

RESOLVED, that the Supervisor of the Town of Cheektowaga be and hereby is authorized to execute the aforementioned contract and any and all documents that may be required to effectuate the sale and transfer of all said vehicles and equipment.

2011

Make	Model	VIN #	Miles	Fleet #
Ford	PU 3/4 ton 4 wd	1FTNF21L41EA96745	162544	10
Autocar	14 Ton Tandem Dump	4V2SCBME4LU505423	143452	12
Autocar	14 Ton Tandem Dump	4V2SCBME6LU505424	133816	45
Ford	BackHoe / Loader	C778955	NA	70
-	General Trailer	8AP8097	NA	84
Brush Bandit	200+	5492	NA	107
Ford	3 Ton Dump - F450	1FDXF47P34EA67347	80500	111
Ford	4 Ton Dump F-550	1FDAF57P04EA67351	77000	112
John Deere	800 Snow Mobile	JD800831351M	93	NA
Cocoa Mats	Asphalt Roller	-	-	-
Ingersol Rand	Air Compressor	-	-	-
Hercules	Fan Impeller	-	-	-
Western	8' Plow	-	-	-
Meyers	8' Plow	-	-	-
Ford	3 cyl Diesel Engine	-	-	-
-	Fuel Transfer Tank	-	-	-
Sterling	Bumper take offs	-	-	-
Eagle Lift	PY lift gate	-	-	-

RESULT: ADOPTED [UNANIMOUS]
MOVER: Jeff Swiatek, Councilmember
SECONDER: Mary Holtz, Supervisor
AYES: Holtz, Jaworowicz, Swiatek, Rogowski, Zydel, Markel, Kaznowski



10. RESOLUTION 2011-315

Approval of Hickory Grove Village Subdivision, Phase II Subdivision Plat Map

Sponsored By: Supervisor Holtz, Councilmember Kaznowski

WHEREAS, by resolution dated March 7, 2005, this Town Board issued environmental and site plan approvals for the proposed Hickory Grove Village Subdivision for the construction of 77 patio homes located on the south side of French Road west of Yvette Drive, AND

WHEREAS, by resolution dated September 11, 2006 this Town Board approved the Phase I Subdivision plat map for the Hickory Grove Village Subdivision, AND,

WHEREAS, the developer has submitted the proposed subdivision plat map for Phase II of the Hickory Grove Village Subdivision to Town departments for review and approval, AND

WHEREAS, the Town Highway Superintendent, Town Engineer and Supervising Code Enforcement Officer have reviewed such proposed subdivision map and have recommended approval of same, NOW, THEREFORE, BE IT

RESOLVED, that this Town Board hereby approves the aforementioned Hickory Grove Village Subdivision, Phase II Subdivision plat map.

RESULT:	ADOPTED [UNANIMOUS]
MOVER:	Mary Holtz, Supervisor
SECONDER:	Stanley Kaznowski, Councilmember
AYES:	Holtz, Jaworowicz, Swiatek, Rogowski, Zydel, Markel, Kaznowski



11. RESOLUTION 2011-316

Notice to Bidders - One (1) New and Unused Flameless Pothole Patcher

Sponsored By: Councilmember Swiatek, Supervisor Holtz

WHEREAS, the Town Clerk be and hereby is directed to publish a Notice to Bidders for the purchase of One (1) New and Unused Flameless Pothole Patcher by the Highway Department.

Information for bidders and specifications may be obtained from the Office of the Town Clerk, Cheektowaga Town Hall, Broadway and Union Roads, Cheektowaga, New York, between the hours of 9:00 AM and 4:30 PM, Monday through Friday, NOW THEREFORE, BE IT

RESOLVED, that the Town Clerk is hereby designated as the Officer to open bids on the aforesaid items at a public bid opening to be held on June 15, 2011 at 11:00 AM, in the Council Chambers of the Cheektowaga Town Hall.

TOWN OF CHEEKTOWAGA HIGHWAY DEPARTMENT LEGAL NOTICE TO BIDDERS

NOTICE IS HEREBY GIVEN, that the Town of Cheektowaga Highway Department will receive bids for the purchase of One (1) New and Unused Flameless Pothole Patcher for use by the Highway Department in the Town of Cheektowaga at a public bid opening to be held in the Council Chambers at the Cheektowaga Town Hall on June 15, 2011 at 11:00 A.M.

Information for bidders and specifications may be obtained from the office of Alice Magierski, Town Clerk at her office located at Town Hall, Cheektowaga NY. Bids must be enclosed in an opaque envelope plainly marked "BID FOR ONE (1) NEW AND UNUSED FLAMELESS POTHOLE PATCHER." Non-Collusion forms must be signed and submitted with each bid. The Superintendent of Highways may reject any or all bids submitted.

Alice Magierski, TOWN CLERK

DATE: June 6, 2011

PUBLISHED: June 9, 2011

RESULT:	ADOPTED [UNANIMOUS]
MOVER:	Jeff Swiatek, Councilmember
SECONDER:	Mary Holtz, Supervisor
AYES:	Holtz, Jaworowicz, Swiatek, Rogowski, Zydel, Markel, Kaznowski



12. RESOLUTION 2011-317

Notice to Bidders - Demolition of 24E Glenwood Court

Sponsored By: Councilmember Markel, Councilmember Kaznowski

WHEREAS, it is in order that bids be advertised for the demolition of a structure located at 24E Glenwood Court in the Town of Cheektowaga, and

WHEREAS, specifications for same have been prepared by Nussbaumer & Clarke, Inc., NOW, THEREFORE, BE IT

RESOLVED, that the Town Clerk be and hereby is directed to publish a Notice to Bidders in connection with the demolition of 24E Glenwood Court, said notice to be published in the CHEEKTOWAGA BEE, and BE IT FURTHER

RESOLVED, that sealed bids will be received and opened by the Town Clerk at a public bid opening to be held in the Council Chambers at the Cheektowaga Town Hall on Wednesday, June 15, 2011 at 11:00 A.M.

NOTICE TO BIDDERS

Sealed proposals will be received by the Town of Cheektowaga on Wednesday, June 15, 2011 at 11:00 A.M. at the Town Hall, 3301 Broadway, Cheektowaga, New York, for the demolition of 24E Glenwood Court in the Town of Cheektowaga.

Information for bidders and specifications may be obtained from the Town Clerk at her office in said Town.

The Town Board reserves the right to consider informal any bid not prepared and submitted in accordance with the provisions of the specification and contract documents, and may waive any informalities, make an award to other than the low bidder, or reject any or all bids should it be in the best interest of the Town.

BY ORDER OF THE TOWN BOARD OF THE TOWN OF CHEEKTOWAGA, ERIE COUNTY, NEW YORK.

Alice Magierski
Town Clerk

Dated: June 6, 2011

RESULT:	ADOPTED [UNANIMOUS]
MOVER:	Charles Markel, Councilmember
SECONDER:	Stanley Kaznowski, Councilmember
AYES:	Holtz, Jaworowicz, Swiatek, Rogowski, Zydel, Markel, Kaznowski



13. RESOLUTION 2011-318

Notice to Bidders - Demolition of 27 Alpine Place

Sponsored By: Councilmember Markel, Councilmember Kaznowski

WHEREAS, it is in order that bids be advertised for the demolition of a structure located at 27 Alpine Place in the Town of Cheektowaga, and

WHEREAS, specifications for same have been prepared by Nussbaumer & Clarke, Inc., NOW, THEREFORE, BE IT

RESOLVED, that the Town Clerk be and hereby is directed to publish a Notice to Bidders in connection with the demolition of 27 Alpine Place, said notice to be published in the CHEEKTOWAGA BEE, and BE IT FURTHER

RESOLVED, that sealed bids will be received and opened by the Town Clerk at a public bid opening to be held in the Council Chambers at the Cheektowaga Town Hall on Wednesday, June 15, 2011 at 11:00 A.M.

NOTICE TO BIDDERS

Sealed proposals will be received by the Town of Cheektowaga on Wednesday, June 15, 2011 at 11:00 A.M. at the Town Hall, 3301 Broadway, Cheektowaga, New York, for the demolition of 27 Alpine Place in the Town of Cheektowaga.

Information for bidders and specifications may be obtained from the Town Clerk at her office in said Town.

The Town Board reserves the right to consider informal any bid not prepared and submitted in accordance with the provisions of the specification and contract documents, and may waive any informalities, make an award to other than the low bidder, or reject any or all bids should it be in the best interest of the Town.

BY ORDER OF THE TOWN BOARD OF THE TOWN OF CHEEKTOWAGA, ERIE COUNTY, NEW YORK.

Alice Magierski
Town Clerk

Dated: June 6, 2011

RESULT:	ADOPTED [UNANIMOUS]
MOVER:	Charles Markel, Councilmember
SECONDER:	Stanley Kaznowski, Councilmember
AYES:	Holtz, Jaworowicz, Swiatek, Rogowski, Zydel, Markel, Kaznowski



14. RESOLUTION 2011-319

Special Event - Buick Club of America

Sponsored By: Councilmember Rogowski, Councilmember Zydel

WHEREAS, this Board has reviewed the aforementioned application, which application has been approved by the Town Board on behalf of the Police Department, Highway Department, the Department of Youth and Recreation, and the Facilities Department, and has no objection to same; and

WHEREAS, due to the nature of the event, this Town Board hereby waives the following requirements:

1. Submittal of plan for sanitary facilities;
2. Submittal of site plan;
3. Requirement that application be made at least 60 days prior to the date of the special event;
4. Submittal of Security Plan;
5. Submittal of Fire Prevention/Emergency Services Plan;

NOW, THEREFORE, BE IT

RESOLVED, that this Town Board hereby approves the application of the Buick Club of America to hold its Car Show on Saturday, July 30, 2011 in Cheektowaga Town Park.

RESULT:	ADOPTED [UNANIMOUS]
MOVER:	James Rogowski, Councilmember
SECONDER:	Richard Zydel, Councilmember
AYES:	Holtz, Jaworowicz, Swiatek, Rogowski, Zydel, Markel, Kaznowski



15. RESOLUTION 2011-320

Special Event - Independence Day Celebration

Sponsored By: Councilmember Rogowski, Councilmember Zydel

WHEREAS, by resolution dated May 1, 1995, this Town Board adopted a Special Events policy, which requires anyone wishing to hold a special event in the Town to file an application and supporting documentation, fees, etc. to the Town Clerk prior to the special event, and

WHEREAS, the Cheektowaga Patriotic Commission has made application to hold its Independence Celebration on July 2nd through 4th, 2011 at Town Park beginning at 5:00 p.m., and Parade on July 4th, 2011 at 12:00 Noon beginning on Walden Avenue to Harlem Road and ending at Town Park; and

WHEREAS, this Board has reviewed the aforementioned application, which application has been approved by the Police Department, Highway Department and the Facilities Department, and has no objection to same, and

WHEREAS, due to the nature of the event, this Town Board hereby waives the following requirements:

- 1.Submittal of plan for sanitary facilities;
- 2.Submittal of site plan;
- 3.Submittal of Security Plan;
- 4.Submittal of Fire Prevention/Emergency Services Plan;

NOW, THEREFORE, BE IT

RESOLVED, that this Town Board hereby approves the aforementioned application of the Cheektowaga Patriotic Commission for said celebration and parade to be held on July 2nd, and 4th, 2011; and BE IT FURTHER

RESOLVED, that the Chief of Police be and hereby is directed to provide traffic safety and escort services for such parade and to ensure compliance with Section 1660(a)(6) of the Vehicle and Traffic Law.

RESULT:	ADOPTED [UNANIMOUS]
MOVER:	James Rogowski, Councilmember
SECONDER:	Richard Zydel, Councilmember
AYES:	Holtz, Jaworowicz, Swiatek, Rogowski, Zydel, Markel, Kaznowski



16. RESOLUTION 2011-321

Special Event-German American Festival

Sponsored By: Councilmember Rogowski, Councilmember Zydel

WHEREAS, by resolution dated May 1, 1995, this Town Board adopted a Special Events policy, which requires anyone wishing to hold a special event in the Town to file an application and supporting documentation, fees, etc. to the Town Clerk prior to the special event, and

WHEREAS, the Federation of German-American Societies has made application to hold its annual German-American Festival in Cheektowaga Town Park September 3rd & 4th 2011; and

WHEREAS, this Board has reviewed the aforementioned application, which application has been approved by the Police Department, Parks Department, and Youth and Recreational Services, and has no objection to same, and

WHEREAS, due to the nature of the event, this Town Board hereby waives the following requirements:

1. Submittal of plan for sanitary facilities;
2. Submittal of site plan;
3. Submittal of Security Plan;
4. Submittal of Fire Prevention/Emergency Services Plan;

NOW, THEREFORE, BE IT

RESOLVED, that this Town Board hereby approves the aforementioned application of the Federation of German-American Societies for the aforementioned German-American Festival to be held in Cheektowaga Town Park on September 3rd & 4th, 2011.

RESULT:	ADOPTED [UNANIMOUS]
MOVER:	James Rogowski, Councilmember
SECONDER:	Richard Zydel, Councilmember
AYES:	Holtz, Jaworowicz, Swiatek, Rogowski, Zydel, Markel, Kaznowski



17. RESOLUTION 2011-322

Special Event - Infant of Prague Church

Sponsored By: Councilmember Rogowski, Councilmember Zydel

WHEREAS, by resolution dated May 1, 1995, this Town Board adopted a Special Events policy, which requires anyone wishing to hold a special event in the Town to file an application and supporting documentation, fees, etc. to the Town Clerk prior to the special event, AND

WHEREAS, Infant of Prague Church has made application to hold its "Church Carnival" (two (2) block street closing) on Friday, August 26th and Saturday, August 27th, 2011 from 8:00 a.m. Friday until 12:00 a.m. Saturday route: (Foisset Ave. from Cleveland Dr. to the end of the church property) AND

WHEREAS, this Board has reviewed the aforementioned application, which application has been approved by the Police Department, Highway Department and the Facilities Department, and has no objection to same, AND

WHEREAS, due to the nature of the event, this Town Board hereby waives the following requirements:

- 1) Submittal of plan for sanitary facilities;
- 2) Submittal of site plan;
- 3) Requirement that application be made at least 60 days prior to the date of the special event;
- 4) Submittal of Security Plan;
- 5) Submittal of Fire Prevention/Emergency Services Plan; NOW, THEREFORE, BE

IT

RESOLVED, that this Town Board hereby approves the aforementioned application of Infant of Prague Church for the said Church Carnival (two (2) block street closing) Friday, August 26th and Saturday, August 27th, 2011 from 8:00 a.m. Friday until 12:00 a.m. Saturday; AND BE IT FURTHER

RESOLVED, that the Chief of Police be and hereby is directed to provide traffic safety and escort services for such run and to ensure compliance with Section 1600(a)(6) of the Vehicle and Traffic Law; AND BE IT FURTHER

RESOLVED, that the Town Clerk shall forward a copy of this resolution to the Chief of Police Dave Zack.

RESULT:	ADOPTED [UNANIMOUS]
MOVER:	James Rogowski, Councilmember
SECONDER:	Richard Zydel, Councilmember
AYES:	Holtz, Jaworowicz, Swiatek, Rogowski, Zydel, Markel, Kaznowski



18. RESOLUTION 2011-323

Unsafe-Unsecured/43 Cloverdale Road

Sponsored By: Councilmember Markel, Councilmember Kaznowski

WHEREAS, Town of Cheektowaga Law for the Administration and Enforcement of the Codes of New York State; and the Property Maintenance Code of New York State require that all vacant structures and premises shall be maintained in clean, safe, secure and sanitary conditions so as not to cause a blighting problem or adversely affect the public health or safety and all nuisances abated, AND

WHEREAS, the Town of Cheektowaga has received notification of an unsafe structure and premises located at 43 Cloverdale Road, Cheektowaga, New York SBL# 91.06-11-12 that is a danger to the safety of others, and records kept by the Assessors Office identify Cathleen M. Gagola, 43 Cloverdale, Cheektowaga, New York 14225, as the owner AND

WHEREAS, an inspection of such premises was conducted at 43 Cloverdale Road, by the Housing and Neighborhood Preservation Office, AND

WHEREAS, such inspection found the premises to be deteriorated, vacant, a hazard, and a danger to the safety and well being of others, AND

WHEREAS, the Town of Cheektowaga Housing and Neighborhood Preservation Office properly notified the property owner in accordance with the Town of Cheektowaga Law for the Administration and Enforcement of the Codes of New York State, and the owner failed to take actions to safeguard the premises, AND

WHEREAS, these conditions require the Town of Cheektowaga Housing and Neighborhood Preservation Office to take immediate steps to safeguard the premises to protect the health and safety of others and abate all nuisances, NOW, THEREFORE BE IT

RESOLVED, that pursuant to Section 70-7A.(5) and Section 70-8 of the Town of Cheektowaga Law for the Administration and Enforcement of the Codes of New York State that the vacant structure premises be safeguarded and all nuisances abated; and all costs incurred be assessed against the property hereinbefore described

RESULT:	ADOPTED [UNANIMOUS]
MOVER:	Charles Markel, Councilmember
SECONDER:	Stanley Kaznowski, Councilmember
AYES:	Holtz, Jaworowicz, Swiatek, Rogowski, Zydel, Markel, Kaznowski



19. RESOLUTION 2011-324

Unsafe-Unsecured/169 Garland Avenue

Sponsored By: Councilmember Markel, Councilmember Kaznowski

WHEREAS, Town of Cheektowaga Law for the Administration and Enforcement of the Codes of New York State; and the Property Maintenance Code of New York State require that all vacant structures and premises shall be maintained in clean, safe, secure and sanitary conditions so as not to cause a blighting problem or adversely affect the public health or safety and all nuisances abated, AND

WHEREAS, the Town of Cheektowaga has received notification of an unsafe structure and premises located at 169 Garland Avenue, Cheektowaga, New York SBL# 113.63-2-24 that is a danger to the safety of others, and records kept by the Assessors Office identify Norman S. Kazmierczak and Wife, 169 Garland Avenue, Cheektowaga, New York 14206, as the owner AND

WHEREAS, an inspection of such premises was conducted at 169 Garland Avenue, by the Housing and Neighborhood Preservation Office, AND

WHEREAS, such inspection found the premises to be deteriorated, vacant, a hazard, and a danger to the safety and well being of others, AND

WHEREAS, the Town of Cheektowaga Housing and Neighborhood Preservation Office properly notified the property owner in accordance with the Town of Cheektowaga Law for the Administration and Enforcement of the Codes of New York State, and the owner failed to take actions to safeguard the premises, AND

WHEREAS, these conditions require the Town of Cheektowaga Housing and Neighborhood Preservation Office to take immediate steps to safeguard the premises to protect the health and safety of others and abate all nuisances, NOW, THEREFORE BE IT

RESOLVED, that pursuant to Section 70-7A.(5) and Section 70-8 of the Town of Cheektowaga Law for the Administration and Enforcement of the Codes of New York State that the vacant structure premises be safeguarded and all nuisances abated; and all costs incurred be assessed against the property hereinbefore described

RESULT:	ADOPTED [UNANIMOUS]
MOVER:	Charles Markel, Councilmember
SECONDER:	Stanley Kaznowski, Councilmember
AYES:	Holtz, Jaworowicz, Swiatek, Rogowski, Zydel, Markel, Kaznowski



20. RESOLUTION 2011-325

Unsafe-Unsecured/29E Glenwood Court

Sponsored By: Councilmember Markel, Councilmember Kaznowski

WHEREAS, Town of Cheektowaga Law for the Administration and Enforcement of the Codes of New York State; and the Property Maintenance Code of New York State require that all vacant structures and premises shall be maintained in clean, safe, secure and sanitary conditions so as not to cause a blighting problem or adversely affect the public health or safety and all nuisances abated, AND

WHEREAS, the Town of Cheektowaga has received notification of an unsafe structure and premises located at 29E Glenwood Court, Cheektowaga, New York SBL# 91.15-2-21 that is a danger to the safety of others, and records kept by the Assessors Office identify John W. Koksich, 29E Glenwood Court, Cheektowaga, New York 14225, as the owner AND

WHEREAS, an inspection of such premises was conducted at 29E Glenwood Court, by the Housing and Neighborhood Preservation Office, AND

WHEREAS, such inspection found the premises to be deteriorated, vacant, a hazard, and a danger to the safety and well being of others, AND

WHEREAS, the Town of Cheektowaga Housing and Neighborhood Preservation Office properly notified the property owner in accordance with the Town of Cheektowaga Law for the Administration and Enforcement of the Codes of New York State, and the owner failed to take actions to safeguard the premises, AND

WHEREAS, these conditions require the Town of Cheektowaga Housing and Neighborhood Preservation Office to take immediate steps to safeguard the premises to protect the health and safety of others and abate all nuisances, NOW, THEREFORE BE IT

RESOLVED, that pursuant to Section 70-7A.(5) and Section 70-8 of the Town of Cheektowaga Law for the Administration and Enforcement of the Codes of New York State that the vacant structure premises be safeguarded and all nuisances abated; and all costs incurred be assessed against the property hereinbefore described

RESULT:	ADOPTED [UNANIMOUS]
MOVER:	Charles Markel, Councilmember
SECONDER:	Stanley Kaznowski, Councilmember
AYES:	Holtz, Jaworowicz, Swiatek, Rogowski, Zydel, Markel, Kaznowski



21. RESOLUTION 2011-326

Unsafe-Unsecured/95 Huth Road

Sponsored By: Councilmember Markel, Councilmember Kaznowski

WHEREAS, Town of Cheektowaga Law for the Administration and Enforcement of the Codes of New York State; and the Property Maintenance Code of New York State require that all vacant structures and premises shall be maintained in clean, safe, secure and sanitary conditions so as not to cause a blighting problem or adversely affect the public health or safety and all nuisances abated, AND

WHEREAS, the Town of Cheektowaga has received notification of an unsafe structure and premises located at 95 Huth Road, Cheektowaga, New York SBL# 91.06-18-1 that is a danger to the safety of others, and records kept by the Assessors Office identify Marjorie E. Rickert, 95 Huth Road, Cheektowaga, New York 14225, as the owner AND

WHEREAS, an inspection of such premises was conducted at 95 Huth Road, by the Housing and Neighborhood Preservation Office, AND

WHEREAS, such inspection found the premises to be deteriorated, vacant, a hazard, and a danger to the safety and well being of others, AND

WHEREAS, the Town of Cheektowaga Housing and Neighborhood Preservation Office properly notified the property owner in accordance with the Town of Cheektowaga Law for the Administration and Enforcement of the Codes of New York State, and the owner failed to take actions to safeguard the premises, AND

WHEREAS, these conditions require the Town of Cheektowaga Housing and Neighborhood Preservation Office to take immediate steps to safeguard the premises to protect the health and safety of others and abate all nuisances, NOW, THEREFORE BE IT

RESOLVED, that pursuant to Section 70-7A.(5) and Section 70-8 of the Town of Cheektowaga Law for the Administration and Enforcement of the Codes of New York State that the vacant structure premises be safeguarded and all nuisances abated; and all costs incurred be assessed against the property hereinbefore described

RESULT:	ADOPTED [UNANIMOUS]
MOVER:	Charles Markel, Councilmember
SECONDER:	Stanley Kaznowski, Councilmember
AYES:	Holtz, Jaworowicz, Swiatek, Rogowski, Zydel, Markel, Kaznowski



22. RESOLUTION 2011-327

Unsafe-Unsecured/47 Marilyn Drive

Sponsored By: Councilmember Markel, Councilmember Kaznowski

WHEREAS, Town of Cheektowaga Law for the Administration and Enforcement of the Codes of New York State; and the Property Maintenance Code of New York State require that all vacant structures and premises shall be maintained in clean, safe, secure and sanitary conditions so as not to cause a blighting problem or adversely affect the public health or safety and all nuisances abated, AND

WHEREAS, the Town of Cheektowaga has received notification of an unsafe structure and premises located at 47 Marilyn Drive, Cheektowaga, New York SBL# 92.09-2-30 that is a danger to the safety of others, and records kept by the Assessors Office identify Nelson E. Moore, 47 Marilyn Drive, Cheektowaga, New York 14225, as the owner AND

WHEREAS, an inspection of such premises was conducted at 47 Marilyn Drive, by the Housing and Neighborhood Preservation Office, AND

WHEREAS, such inspection found the premises to be deteriorated, vacant, a hazard, and a danger to the safety and well being of others, AND

WHEREAS, the Town of Cheektowaga Housing and Neighborhood Preservation Office properly notified the property owner in accordance with the Town of Cheektowaga Law for the Administration and Enforcement of the Codes of New York State, and the owner failed to take actions to safeguard the premises, AND

WHEREAS, these conditions require the Town of Cheektowaga Housing and Neighborhood Preservation Office to take immediate steps to safeguard the premises to protect the health and safety of others and abate all nuisances, NOW, THEREFORE BE IT

RESOLVED, that pursuant to Section 70-7A.(5) and Section 70-8 of the Town of Cheektowaga Law for the Administration and Enforcement of the Codes of New York State that the vacant structure premises be safeguarded and all nuisances abated; and all costs incurred be assessed against the property hereinbefore described

RESULT:	ADOPTED [UNANIMOUS]
MOVER:	Charles Markel, Councilmember
SECONDER:	Stanley Kaznowski, Councilmember
AYES:	Holtz, Jaworowicz, Swiatek, Rogowski, Zydel, Markel, Kaznowski



23. RESOLUTION 2011-328

Unsafe-Unsecured/166 Straley Avenue

Sponsored By: Councilmember Markel, Councilmember Kaznowski

WHEREAS, Town of Cheektowaga Law for the Administration and Enforcement of the Codes of New York State; and the Property Maintenance Code of New York State require that all vacant structures and premises shall be maintained in clean, safe, secure and sanitary conditions so as not to cause a blighting problem or adversely affect the public health or safety and all nuisances abated, AND

WHEREAS, the Town of Cheektowaga has received notification of an unsafe structure and premises located at 166 Straley Avenue, Cheektowaga, New York SBL# 102.37-2-13 that is a danger to the safety of others, and records kept by the Assessors Office identify Kathryn A. Barajas, 166 Straley Avenue, Cheektowaga, New York 14211, as the owner AND

WHEREAS, an inspection of such premises was conducted at 166 Straley Avenue, by the Housing and Neighborhood Preservation Office, AND

WHEREAS, such inspection found the premises to be deteriorated, vacant, a hazard, and a danger to the safety and well being of others, AND

WHEREAS, the Town of Cheektowaga Housing and Neighborhood Preservation Office properly notified the property owner in accordance with the Town of Cheektowaga Law for the Administration and Enforcement of the Codes of New York State, and the owner failed to take actions to safeguard the premises, AND

WHEREAS, these conditions require the Town of Cheektowaga Housing and Neighborhood Preservation Office to take immediate steps to safeguard the premises to protect the health and safety of others and abate all nuisances, NOW, THEREFORE BE IT

RESOLVED, that pursuant to Section 70-7A.(5) and Section 70-8 of the Town of Cheektowaga Law for the Administration and Enforcement of the Codes of New York State that the vacant structure premises be safeguarded and all nuisances abated; and all costs incurred be assessed against the property hereinbefore described

RESULT:	ADOPTED [UNANIMOUS]
MOVER:	Charles Markel, Councilmember
SECONDER:	Stanley Kaznowski, Councilmember
AYES:	Holtz, Jaworowicz, Swiatek, Rogowski, Zydel, Markel, Kaznowski



24. RESOLUTION 2011-329

Unsafe-Unsecured/1002 Walden Avenue

Sponsored By: Councilmember Markel, Councilmember Kaznowski

WHEREAS, Town of Cheektowaga Law for the Administration and Enforcement of the Codes of New York State; and the Property Maintenance Code of New York State require that all vacant structures and premises shall be maintained in clean, safe, secure and sanitary conditions so as not to cause a blighting problem or adversely affect the public health or safety and all nuisances abated, AND

WHEREAS, the Town of Cheektowaga has received notification of an unsafe structure and premises located at 1002 Walden Avenue, Cheektowaga, New York SBL# 101.60-1-15 that is a danger to the safety of others, and records kept by the Assessors Office identify U. S. Bank National Association, Cincinnati, OH 45202, as the owner AND

WHEREAS, an inspection of such premises was conducted at 1002 Walden Avenue, by the Housing and Neighborhood Preservation Office, AND

WHEREAS, such inspection found the premises to be deteriorated, vacant, a hazard, and a danger to the safety and well being of others, AND

WHEREAS, the Town of Cheektowaga Housing and Neighborhood Preservation Office properly notified the property owner in accordance with the Town of Cheektowaga Law for the Administration and Enforcement of the Codes of New York State, and the owner failed to take actions to safeguard the premises, AND

WHEREAS, these conditions require the Town of Cheektowaga Housing and Neighborhood Preservation Office to take immediate steps to safeguard the premises to protect the health and safety of others and abate all nuisances, NOW, THEREFORE BE IT

RESOLVED, that pursuant to Section 70-7A.(5) and Section 70-8 of the Town of Cheektowaga Law for the Administration and Enforcement of the Codes of New York State that the vacant structure premises be safeguarded and all nuisances abated; and all costs incurred be assessed against the property hereinbefore described

RESULT:	ADOPTED [UNANIMOUS]
MOVER:	Charles Markel, Councilmember
SECONDER:	Stanley Kaznowski, Councilmember
AYES:	Holtz, Jaworowicz, Swiatek, Rogowski, Zydel, Markel, Kaznowski



25. RESOLUTION 2011-330

Retain Drug Court Case Coordinator

Sponsored By: Councilmember Jaworowicz, Councilmember Rogowski

WHEREAS, the Town of Cheektowaga, through the Cheektowaga Justice Court, has operated an Adult Drug Court since 1997, and

WHEREAS, this Town Board, by prior resolutions, has engaged the services of Irene Kmiolek as a Drug Court Case Coordinator; and

WHEREAS, Irene Kmiolek has satisfactorily performed the required Drug Court Case Coordinator duties; and

WHEREAS, this Town Board hereby desires to continue to retain the services of Irene Kmiolek as Drug Court Case Coordinator; NOW THEREFORE BE IT

RESOLVED, that this Town hereby ratifies the retention of Irene Kmiolek of Depew, New York, as Consultant, to perform the duties of Drug Court Case Coordinator effective January 1, 2011 to December 31, 2011, at an hourly rate of \$20.00 per hour, not to exceed nineteen (19) hours per week; and BE IT FURTHER

RESOLVED, that the Supervisor is authorized and directed to execute all Agreement(s) with Irene Kmiolek for the above services that may be required, subject to approval of same by the Town Attorney's Office; and BE IT FURTHER

RESOLVED, that said monies shall be appropriated from budget line item number 0100-1110-4592.

RESULT:	ADOPTED [UNANIMOUS]
MOVER:	Patricia Jaworowicz, Councilmember
SECONDER:	James Rogowski, Councilmember
AYES:	Holtz, Jaworowicz, Swiatek, Rogowski, Zydel, Markel, Kaznowski



26. RESOLUTION 2011-331

Authorization to Retain Foreign Language Interpreters for Justice Court

Sponsored By: Councilmember Jaworowicz, Councilmember Rogowski

WHEREAS, the New York State Unified Court System, Eighth Judicial District, requires the Cheektowaga Justice Court to provide qualified foreign language and sign language interpreters in all civil and criminal matters if a party does not speak or understand the English language; and

WHEREAS, the Unified Court System has provided the Justice Court with a list of the names of qualified interpreters in various languages, all of whom meet the necessary requirements and are qualified by education and experience to provide such services; and

WHEREAS, the Town is desirous of retaining such interpreters for use in civil and criminal matters on a *per diem* basis when the need arises; NOW, THEREFORE, BE IT

RESOLVED, that this Town Board hereby approves the retention of foreign language and sign language interpreters for use in civil and criminal matters before the Justice Court, on a *per diem* basis, provided said interpreters meet the qualifications, requirements, and certification necessary to perform interpretation services in a legal and courtroom environment; and BE IT FURTHER

RESOLVED, that an interpreter shall be chosen first from an up-to-date list of qualified *per diem* foreign and sign language interpreters as such list is provided by the New York State Unified Court System, Eighth Judicial District, or, if said list does not contain the name of an interpreter for the particular language required, then from any other source that will provide an interpreter meeting the requirements of the Unified Court System; and BE IT FURTHER

RESOLVED, that the cost for said interpreters shall be appropriated from line item number 100-1110-4592; and BE IT FURTHER

RESOLVED, that subject to approval by the Town Attorney, the Supervisor is hereby authorized to execute agreements for the services of interpreters during calendar year 2011.

RESULT:	ADOPTED [UNANIMOUS]
MOVER:	Patricia Jaworowicz, Councilmember
SECONDER:	James Rogowski, Councilmember
AYES:	Holtz, Jaworowicz, Swiatek, Rogowski, Zydel, Markel, Kaznowski



27. RESOLUTION 2011-332

Retain the Services of Court Stenographers for 2011

Sponsored By: Councilmember Jaworowicz, Councilmember Rogowski

WHEREAS, the Town of Cheektowaga in need of the services of stenographers for civil, criminal, and miscellaneous matters in the Justice Court and other Town departments in which transcripts and records of said proceedings are required; and

WHEREAS, the Town has, in the past, retained the services of various qualified and experienced court reporters who have provided such services when needed; NOW, THEREFORE, BE IT

RESOLVED, that this Town Board approves the retention of qualified and experienced court stenographers for the calendar year 2011 when such services are required by the Town including, but not limited to, the following named persons and agency: Paula Bielat, Martha Emiliana, Deborah Delalys, Diana Proudman, and DePaolo Crosby Reporting Services, and BE IT FURTHER

RESOLVED, that the cost of these services shall be charged to the line items designated for said expenses for the respective department; and BE IT FURTHER

RESOLVED, that subject to approval of the Town Attorney, the Supervisor is authorized to execute Agreements for the above services for the calendar year 2011.

RESULT:	ADOPTED [UNANIMOUS]
MOVER:	Patricia Jaworowicz, Councilmember
SECONDER:	James Rogowski, Councilmember
AYES:	Holtz, Jaworowicz, Swiatek, Rogowski, Zydel, Markel, Kaznowski



28. RESOLUTION 2011-333

Youth & Recreation Terminations

Sponsored By: Councilmember Zydel, Councilmember Rogowski

BE IT RESOLVED that the individuals listed below be and hereby are terminated in the Department of Youth & Recreational Services, effective as indicated:

Ashley Grabiec	08/20/10	14225
Dana Szymkowiak	03/11/11	14227

Motion by Supervisor Holtz; Seconded by Councilmember Rogowski to Waive the Reading of Names for the following resolutions: 2011-333; 2011-334 and 2011-335. Motion Carried.

RESULT: ADOPTED [UNANIMOUS]
MOVER: Richard Zydel, Councilmember
SECONDER: James Rogowski, Councilmember
AYES: Holtz, Jaworowicz, Swiatek, Rogowski, Zydel, Markel, Kaznowski



29. RESOLUTION 2011-334

Youth & Recreation Hiring/Transfers

Sponsored By: Councilmember Zydel, Councilmember Rogowski

BE IT RESOLVED that the individuals listed below be and hereby are hired and/or transferred, as indicated, in the Department of Youth & Recreational Services, effective immediately:

Recreation Attendant - 7140.1642 - \$8.00 - Seasonal

Julia Harvey 14225

Recreation Attendant - 7140.1642 - \$7.75 - Seasonal

Gary Steltermann 14225

Recreation Attendant - 7140.1642 - \$7.35 - Seasonal

Melanie Grzebinski 14227

Sarah Kojm 14215

Recreation Attendant - 7140.1642 - \$7.25 - Seasonal

John Nazzarett 14227

Recreation Attendant - 7140.1646 - \$7.25 - Seasonal

Tyia Acoff 14215

Recreation Attendant - 7140.1613 - \$10.00 - Regular Part-time

Elizabeth Haynes 14225

Recreation Instructor - 7140.1632 - \$9.25 - Effective 5/10/11 - Seasonal

Jacquelyn Rieck 14225

Laborer "Level II Participant CCC" 7180.1816 - \$7.50 - Seasonal

Robert Bommer 14225

Lifeguard - "Level I" - 7180.1903 - \$8.25 - Seasonal

Catherine Huber 14225

Melissa Huber 14225

Samantha Johnston 14206

Trevor Karek 14225

Allison Musial 14225

Aaron Wanat 14043

Michael Zarbo 14227

Lifeguard - "Level I" Alternate - 7180.1903 - \$8.25 - Seasonal

Marissa Floyd 14215

Jennifer Merckling 14043

Alana Nguyen 14225

Lifeguard - "Level II" - 7180.1903 - \$8.42 - Seasonal

John Zastempowski 14227

Laborer "Bath House Level I" - 7180.1901- \$7.25 - Seasonal

Michaela Barone	14225
Samantha Burton	14225
Danielle Chmurzynski	14225
Rachel Hermanski	14225
Donte' Hood	14225
David Kerling	14225
Emily Metzger	14225
Alicia Misiak	14227
Toni Morrison	14225
Paul A. Nazzarett	14227
Tyler Pawlowski	14225
Emily Speidel	14225
Alexandria Wnuk	14043

Laborer "Bath House Level II" - 7180.1901- \$7.50 - Seasonal

Kelly Astyk	14227
Levi Bourdette	14225
Michael Gandt	14043
Sarah Kapanek	14206
Nathan Meyers	14225
Jacob Radlich	14225
James Rogers	14206
Alyssa Slinkosky	14225
Ashley Sokol	14227
Korrey Williams	14227

Laborer "Bath House Level I" Alternates - 7180.1901- \$7.25 - Seasonal

Noah McGhee	14225
Mark Stucke	14225
Julianne Doetterl	14227
Alex Eisenhauer	14225
Heidi Maziarz	14043
Hajan Quarles	14211
Catherine Weibel	14225
Christian Suszek	14206
Denzel Adside	14211
Patrick Crissy	14225

Recreation Attendant - 7310.1810 - Camp Flamingo - \$7.50 - Seasonal

Jillian Adamczak	14211
Evan Bernard	14215
Alexis Blachowski	14225
Lauren Boehm	14225
Joshua Fruchtel	14211
Kara Jeziorski	14227
Stephen Kelly	14211
Julie Laffrado	14225
Carolyn Reczek	14227
Robyn Stanley	14225
Rebecca Szyjka	14227
Theresa Tripi	14227
Nicole Wyzykowski	14206

Recreation Instructor - 7310.1810 - Camp Flamingo - \$8.25 - Seasonal

Charlie Jane Clark	14215
Ann Marie Heide	14225

Recreation Attendant - 7310.1810 - Camp Flamingo - \$7.25 - Seasonal

Alysia Kent	14225
Mary Wroblewski	14227

Recreation Aide - 7310.1810 - Camp Flamingo - \$7.25 - Part-time

Ashley Carney	14225
Olivia Constantine	14225
Jessica Elston	14225
Rebecca Langa	14043
Anthony Pachetti	14225
Samantha Poules	14227

Recreation Attendant - 7310.1802 - Camp Crabapple - \$7.25 - Seasonal

Jessica Ruda	14227
Holly Sobkowiak	14043

Recreation Attendant - 7310.1802 - Camp Crabapple - \$7.65 - Seasonal

Merissa Ciesielski	14225
--------------------	-------

Recreation Attendant - 7310.1802 - Camp Crabapple - \$7.90 - Seasonal

Meghan Eckle	14225
--------------	-------

Recreation Aide - 7310.1802 - Camp Crabapple - \$7.25 - Part-time

Lillith Boyd-Gamel	14225
Austin Lauer	14225
Steven Mazurkiewicz	14225
Sierra Schraufstetter	14225

Recreation Attendant - 7140.1632 - Camp Dartwood - \$7.90 - Seasonal

Lori Majewski	14227
---------------	-------

Recreation Attendant - 7140.1632 - Camp Dartwood - \$7.50 - Seasonal

Joseph Malicki	14043
Kristen Schugardt	14043

Recreation Attendant - 7140.1632 - Camp Dartwood - \$7.55 - Seasonal

Tabitha Slachciak	14212
-------------------	-------

Recreation Attendant - 7140.1632 - Camp Dartwood - \$7.25 - Seasonal

Lauren Bujnicki	14227
Joshua Tedesco	14227

Recreation Attendant - 7310.1801 Camp JI-IK-DO-WAH-GAH - \$7.25 - Seasonal

Emalee Danner	14225
Allison Herman	14225

Recreation Aide - 7310.1801 Camp JI-IK-DO-WAH-GAH - \$7.25 - Part-time

Joshua Miller	14211
Cassidy Moore	14225

From Adapted Recreation Program 7310.1803 to Camp Crabapple 7310.1802 - \$7.25

Part-time

Cerene Usinski

Recreation Specialist "Pool Director" - 7180.1902 - \$18.63 - Regular Part-time

Cathy Giles

Recreation Attendant - 7140.1804 & 7140.1614 - \$8.75 - Regular Part-time

Amy Bowen

Recreation Attendant - 7140.1648 - \$10.75 - Regular Part-time

Scott Gretch

Recreation Attendant - 7140.1614 - \$7.50 - Regular Part-time

Jamie Russell

RESULT:	ADOPTED [UNANIMOUS]
MOVER:	Richard Zydel, Councilmember
SECONDER:	James Rogowski, Councilmember
AYES:	Holtz, Jaworowicz, Swiatek, Rogowski, Zydel, Markel, Kaznowski



30. RESOLUTION 2011-335

Hiring/Termination of Part-Time/Seasonal Employees

Sponsored By: Councilmember Swiatek, Supervisor Holtz

BE IT RESOLVED, that the following individual be and hereby is hired as a **SEASONAL EMPLOYEE**, not to exceed five (5) months in a calendar year, in the department listed and in compliance with Civil Service Laws and Regulations as well as the provisions of the Town's collective bargaining agreement between the Town of Cheektowaga and the Town of Cheektowaga Employees Association:

Facilities Department (Parks Division) Laborer \$8.00/hour effective 6/7/11
Mark D. Superczynski, Cheektowaga, New York

BE IT RESOLVED, that the following individuals be and hereby are hired as **PART-TIME EMPLOYEES** in the departments listed, not to exceed nineteen (19) hours on a weekly basis, in compliance with Civil Service Laws and Regulations as well as the provisions of the Town's collective bargaining agreement between the Town of Cheektowaga and the Town of Cheektowaga Employees Association:

Facilities Department (Buildings and Grounds Division) Laborer \$8.00/hour effective 6/7/11
William R. Haderer, Cheektowaga, New York

Justice Court - Court Officer (Temporary) \$15.59/hour effective 6/7/11
Daniel Clifford, Cheektowaga, New York

Justice Court - Court Officer (Temporary) \$15.59/hour effective 6/20/11
Gary Edenhofer, Cheektowaga, New York

Justice Court - Court Officer \$15.59/hour effective 6/7/11
Shaun R. Turner, Cheektowaga, New York

BE IT RESOLVED, that the following seasonal and/or part-time employees be and hereby are terminated as listed:

Justice Court
Shaun R. Turner (Temporary Court Officer) effective 6/6/11

Facilities Department
Justin Borowski effective 4/3/11

Sanitation Department
Michael C. McGill effective 5/20/11
Mark Zack effective 5/16/11

Assessor's Office
Allison E. McKay effective 4/8/11

RESULT:	ADOPTED [UNANIMOUS]
MOVER:	Jeff Swiatek, Councilmember
SECONDER:	Mary Holtz, Supervisor
AYES:	Holtz, Jaworowicz, Swiatek, Rogowski, Zydel, Markel, Kaznowski

**31. RESOLUTION 2011-336****Reappointment of Motor Equipment Operator - B to Laborer
(Highway Department/Thomas E. Poules)**

Sponsored By: Councilmember Swiatek, Supervisor Holtz

BE IT RESOLVED, that Thomas E. Poules of Cheektowaga, New York, be and hereby is reappointed from the title of Motor Equipment Operator - B to the title of Laborer in the Highway Department pursuant to the Memorandum of Agreement between the Town and the Town of Cheektowaga Employees Association effective May 23, 2011 through August 20, 2011; AND, BE IT FURTHER

RESOLVED, that Mr. Poules be and hereby shall return to the position of Motor Equipment Operator - B in the Highway Department effective August 21, 2011.

RESULT:	ADOPTED [UNANIMOUS]
MOVER:	Jeff Swiatek, Councilmember
SECONDER:	Mary Holtz, Supervisor
AYES:	Holtz, Jaworowicz, Swiatek, Rogowski, Zydel, Markel, Kaznowski

**32. RESOLUTION 2011-337****Appointment of Laborer (Labor/Permanent) Highway
Department/Todd A. Stucke**

Sponsored By: Councilmember Swiatek, Supervisor Holtz

WHEREAS, a vacancy exists in the title of Laborer in the Highway Department; AND

WHEREAS, notice of such vacancy has been posted in accordance with the provisions of the Town's collective bargaining agreement with the Town of Cheektowaga Employees Association; AND

WHEREAS, Todd A. Stucke, currently employed as a Laborer in the Sanitation Department, bid on said vacancy and meets the necessary qualifications for appointment; NOW, THEREFORE, BE IT

RESOLVED, that Todd A. Stucke of Cheektowaga, New York, be and hereby is appointed to the position of Laborer in the Highway Department in accordance with the terms and conditions of the Town's collective bargaining agreement with the Town of Cheektowaga Employees Association effective June 7, 2011.

RESULT:	ADOPTED [UNANIMOUS]
MOVER:	Jeff Swiatek, Councilmember
SECONDER:	Mary Holtz, Supervisor
AYES:	Holtz, Jaworowicz, Swiatek, Rogowski, Zydel, Markel, Kaznowski

**33. RESOLUTION 2011-338****Appointment of Court Clerk (Temporary) Justice Court/Jill M. Baszczynski**

Sponsored By: Councilmember Jaworowicz, Councilmember Swiatek

WHEREAS, a temporary vacancy exists in the position of Court Clerk in the Justice Court; AND

WHEREAS, there is an immediate need to fill said vacancy while the civil service list is canvassed; AND

WHEREAS, Jill M. Baszczynski, currently a part-time Clerk in the Justice Court, meets the necessary qualifications for appointment; NOW, THEREFORE, BE IT

RESOLVED, that Jill M. Baszczynski, of Cheektowaga, New York, be and hereby is appointed to the temporary position of Court Clerk in the Justice Court in accordance with the terms and conditions of the Town's collective bargaining agreement with the Town of Cheektowaga Employees Association effective June 6, 2011.

RESULT:	ADOPTED [UNANIMOUS]
MOVER:	Patricia Jaworowicz, Councilmember
SECONDER:	Jeff Swiatek, Councilmember
AYES:	Holtz, Jaworowicz, Swiatek, Rogowski, Zydel, Markel, Kaznowski



34. RESOLUTION 2011-339

Travel Authorization Police Department/Captain James Speyer

Sponsored By: Councilmember Jaworowicz, Councilmember Swiatek

WHEREAS, the "Workers' Compensation Law and Practice," seminar is being held July 20, 2011 in Atlantic City, New Jersey; AND

WHEREAS, Captain James Speyer has requested authorization to attend said seminar; AND

WHEREAS, Police Chief David Zack has submitted a request for travel authorization along with the proper paperwork in a timely manner; AND

WHEREAS, the total cost to the Town shall not exceed \$418.38; AND

WHEREAS, these expenses have been budgeted by the Police Department; NOW, THEREFORE, BE IT

RESOLVED, that Captain James Speyer be and hereby is authorized to attend the "Workers' Compensation Law and Practice," seminar being held July 20, 2011 in Atlantic City, New Jersey.

RESULT:	ADOPTED [UNANIMOUS]
MOVER:	Patricia Jaworowicz, Councilmember
SECONDER:	Jeff Swiatek, Councilmember
AYES:	Holtz, Jaworowicz, Swiatek, Rogowski, Zydel, Markel, Kaznowski



35. RESOLUTION 2011-340

Travel Authorization Building and Plumbing Department/Fire Inspector Robert Jaroszewski

Sponsored By: Councilmember Swiatek, Supervisor Holtz

WHEREAS, the "New York State Fire Marshalls and Inspectors Educational Conference," is being held September 29 - 30, 2011 in Skaneateles, New York; AND

WHEREAS, Fire Inspector Robert Jaroszewski has requested authorization to attend said conference; AND

WHEREAS, Supervising Code Enforcement Officer Thomas Adamczak has submitted a request for travel authorization along with the proper paperwork in a timely manner; AND

WHEREAS, the total cost to the Town shall not exceed \$315; AND

WHEREAS, these expenses have been budgeted by the Building and Plumbing Department; NOW, THEREFORE, BE IT

RESOLVED, that Fire Inspector Robert Jaroszewski be and hereby is authorized to attend the "New York State Fire Marshalls and Inspectors Educational Conference," being held September 29 - 30, 2011 in Skaneateles, New York.

RESULT:	ADOPTED [UNANIMOUS]
MOVER:	Jeff Swiatek, Councilmember
SECONDER:	Mary Holtz, Supervisor
AYES:	Holtz, Jaworowicz, Swiatek, Rogowski, Zydel, Markel, Kaznowski

IV. Suspension of Rules

Motion by Councilmember Rogowski; Seconded by Supervisor Holtz to Suspend the Rules to Include the following two (2) resolutions: 2011-341 and 2011-342. Motion Carried.
--



1. RESOLUTION 2011-341

Appointment of Clerk to the Town Justice (Exempt) Justice Court/Kimberly K. Kent-Chojnicki

Sponsored By: Councilmember Swiatek, Supervisor Holtz

WHEREAS, a vacancy exists in the title of Clerk to the Town Justice; AND

WHEREAS, said title is in the exempt class of civil service; AND

WHEREAS, Town Justice Dennis Delano has requested that such title be filled as he does not have an individual to manage, administer and coordinate the various judicial and non-judicial activities and responsibilities associated with his official office; AND

WHEREAS, Kimberly K. Kent-Chojnicki, currently employed as a temporary Court Clerk in the Justice Court, meets the qualifications for appointment; NOW, THEREFORE, BE IT

RESOLVED, that Kimberly K. Kent-Chojnicki of Cheektowaga, New York, be and hereby is appointed to the position of Clerk to the Town Justice effective May 18, 2011.

RESULT:	ADOPTED [UNANIMOUS]
MOVER:	Jeff Swiatek, Councilmember
SECONDER:	Mary Holtz, Supervisor
AYES:	Holtz, Jaworowicz, Swiatek, Rogowski, Zydel, Markel, Kaznowski



2. RESOLUTION 2011-342

Negative SEQR Declaration - 2501 Broadway

Sponsored By: Councilmember Kaznowski, Councilmember Markel

WHEREAS, pursuant to the Environmental Impact Review Ordinance of the Town of Cheektowaga, the Environmental Advisory Committee ("EAC") reviews various applications for site plans, rezonings, special permits, etc. and renders its recommendation concerning the environmental significance of such application, AND

WHEREAS, the Town Board, pursuant to the Environmental Impact Review Ordinance of the Town of Cheektowaga, is designated the Lead Agency in most instances, AND

WHEREAS, since the Town Board is the Lead Agency, it must affirm, modify or reject any recommendations submitted to it by the Advisory Committee, AND

WHEREAS, an application was submitted by Drew Blum of Allied Frozen Storage for the construction of an accessory truck parking area and private access road at 2501 Broadway (sbl nos. 102.03-3-21.1, 102.03-3-24.22 & 102.18-4-4.1) , AND

WHEREAS, the Environmental Advisory Committee at its meetings held on June 1, 2011 recommended a determination of non-significance, AND

WHEREAS, the Town of Cheektowaga Planning Board recommended approval of the site plan at their meeting of April 14, 2011, AND

WHEREAS, the Town of Cheektowaga Traffic Safety Commission has reviewed the subject project, AND

WHEREAS, The Zoning Board of Appeals previously heard a request for an area variance to allow the proposed parking area and driveway, AND

WHEREAS, this Town Board has reviewed the application submitted and the recommendations made by the Environmental Advisory Committee, the Planning Board and the Traffic Safety Commission NOW, THEREFORE, BE IT

RESOLVED, that this Town Board determines that the project will not have a significant effect on the environment and therefore issues a Negative Declaration for purposes of SEQRA, AND BE IT

FURTHER RESOLVED, the proposed site plan is found to be acceptable subject to :

1. The applicant paving the stone area adjacent to the proposed deep dock area within one year of the Town Engineer accepting the mandatory storm maintenance easement agreement from the applicant, pursuant to section 209-9B. of the Town Code.
2. The site plan being amended to specify the proposed bio retention plantings and dark sky friendly exterior site lighting.

3. The Zoning Board of Appeals granting the necessary area variances.

Attachments:

landscape plan (PDF)

RESULT: ADOPTED [UNANIMOUS]**MOVER:** Stanley Kaznowski, Councilmember**SECONDER:** Charles Markel, Councilmember**AYES:** Holtz, Jaworowicz, Swiatek, Rogowski, Zydel, Markel, Kaznowski

V. Communications

A. Departmental Communications

1. Building Permit List - May 2011
2. Minutes: Cheektowaga Conservation Advisory Council - May 5, 2011
3. Minutes: Cheektowaga Traffic Safety Commission - April 19, 2011
4. Minutes: Town Environmental Advisory Committee - May 18, 2011

B. General Communications

1. Notice of Claim: Mark Daniels Vs. Town of Cheektowaa
2. Notice of Claim: Steven J. Halasz Vs. Town of Cheektowaga
3. Notice of Claim: Debra Larkin Vs. Town of Cheektowaga
4. Notice of Claim: Janet & Mike Pietras Vs. Town of Cheektowaga
5. Notice of Claim: Michael Wisniewski Vs. Town of Cheektowaga

VI. Comments

A. Supervisor's Comments

B. Councilmember's Comments

C. Public Comments

VII. Adjournment

Motion by Supervisor Holtz; Seconded by Councilmember Swiatek to adjourn the meeting in memory of Kevin Glascott, retiree of Sanitation Department and Town of Cheektowaga Employees Association Union President..

Alice Magierski
Town Clerk

Amherst HOME Consortium
Town of Cheektowaga
Home Investment Partnership Program
Amended Annual Plan
2011 - HOME #1

The Town of Cheektowaga has amended its use of HOME Investment Partnership Funds as follows:

The following 2009 HOME Program activity is cancelled and \$85,000 in HOME funds allocated to that activity are transferred to the Town's HOME Program Housing Rehabilitation Program.



**PRIVATE DRIVE & TRUCK PARKING FACILITY
 FOR
 ALLIED FROZEN STORAGE, INC.
 260 STATE STREET
 BROCKPORT, NEW YORK**

MARK	DATE	DESCRIPTION
REVISIONS		
PROJECT NO:		
DATE:		
SCALE:		
DRAWN BY:		
CHECKED BY:		
NO ALTERATION PERMITTED HEREON EXCEPT AS PROVIDED UNDER SECTION 2205 SUBDIVISION 2 OF THE NEW YORK EDUCATION LAW		
LANDSCAPE PLAN		
C1.05		

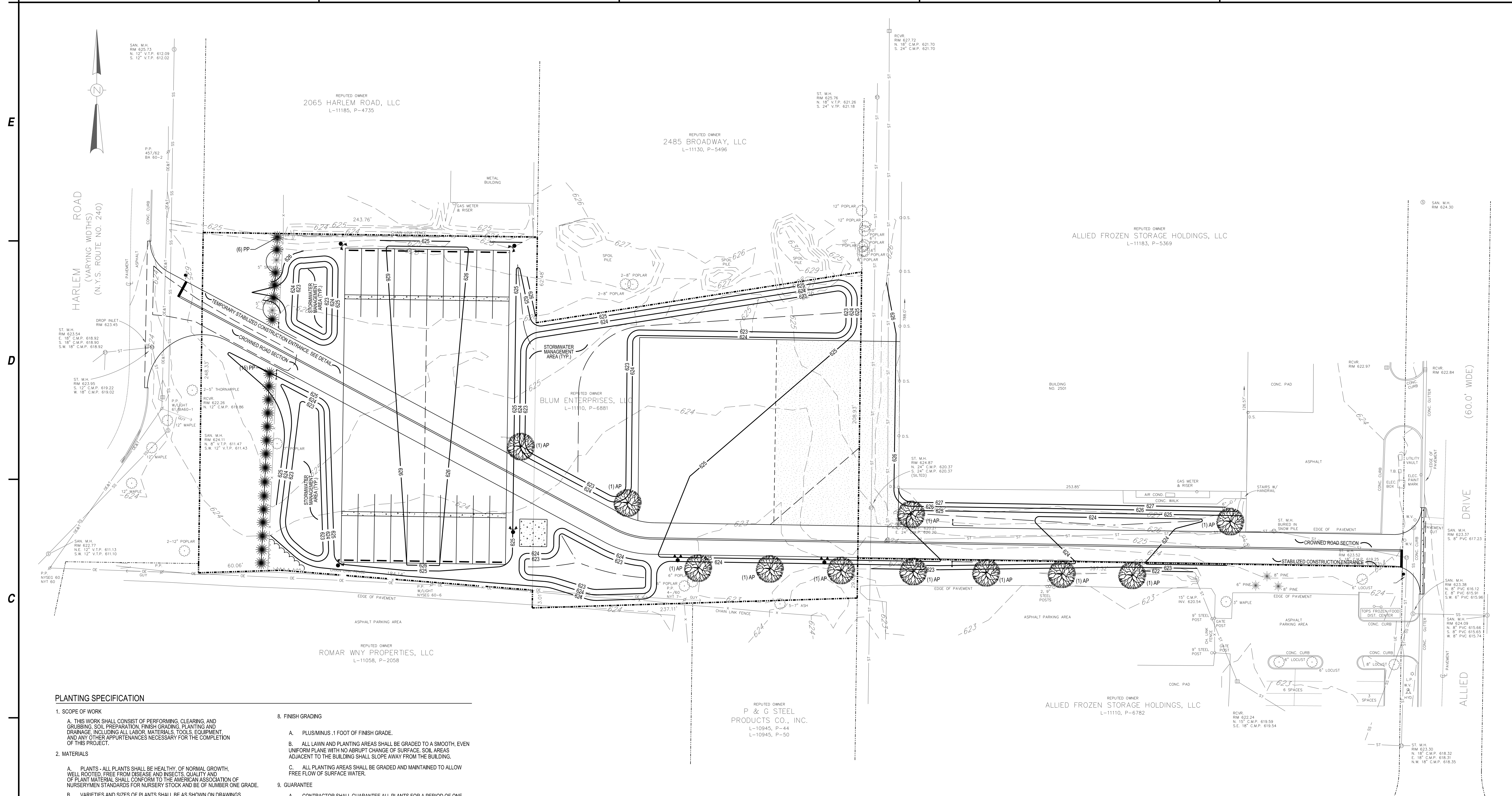

PLANTING SPECIFICATION

- SCOPE OF WORK**
 - THIS WORK SHALL CONSIST OF PERFORMING, CLEARING, AND GRUBBING, SOIL PREPARATION, FINISH GRADING, PLANTING AND DRAINAGE, INCLUDING ALL LABOR, MATERIALS, TOOLS, EQUIPMENT, AND ANY OTHER APPURTENANCES NECESSARY FOR THE COMPLETION OF THIS PROJECT.
- MATERIALS**
 - PLANTS - ALL PLANTS SHALL BE HEALTHY OF NORMAL GROWTH, WELL ROOTED, FREE FROM DISEASE AND INSECTS. QUALITY AND OF PLANT MATERIAL SHALL CONFORM TO THE AMERICAN ASSOCIATION OF NURSERMEN STANDARDS FOR NURSERY STOCK AND BE OF NUMBER ONE GRADE.
 - VARIETIES AND SIZES OF PLANTS SHALL BE AS SHOWN ON DRAWINGS.
- FERTILIZER AND HERBICIDE**
 - FERTILIZER SHALL BE MILORGANITE (6-2-0)
 - PRE-EMERGENT HERBICIDE SHALL BE "PREEN" GRANULAR HERBICIDE
- GENERAL WORK PROCEDURES**
 - LANDSCAPE WORK SHALL BE ACCORDING TO THE WORKMANLIKE STANDARDS ESTABLISHED FOR LANDSCAPE CONSTRUCTION AND PLANTING.
- WEEDING**
 - BEFORE AND DURING PRELIMINARY GRADING AND FINISH GRADING, ALL WEEDS AND GRASSES SHALL BE DUG OUT BY THE ROOTS AND DISPOSED OF AT THE CONTRACTOR'S EXPENSE.
- SOIL CONDITIONING**
 - CULTIVATE ALL AREAS TO BE PLANTED TO A DEPTH OF 6". ALL DEBRIS EXPOSED FROM EXCAVATION AND CULTIVATION SHALL BE DISPOSED OF AT THE CONTRACTOR'S EXPENSE.
- PLANTING**
 - POSITION TREES AND SHRUBS AT THEIR INTENDED LOCATIONS AS PER THE PLANS AND SECURE THE APPROVAL OF THE LANDSCAPE ARCHITECT ARCHITECT BEFORE EXCAVATING PITS, MAKING NECESSARY ADJUSTMENTS AS DIRECTED.
 - PLANTING PITS SHALL BE DUG WITH LEVEL BOTTOMS, AS SHOWN ON THE PLANTING DETAILS.
 - 3 PARTS TOPSOIL
 - 1 PART PEAT MOSS OR COMPOST
 - 1/3 PART MILORGANITE FERTILIZER
 - PREPARED SOIL SHALL BE TAMPED FIRMLY AT BOTTOM OF PIT. FILL PREPARED SOIL AROUND BALL OF PLANT 1/2 WAY, AND WATER. COMPLETE BACK-FILLING AND WATER THOROUGHLY.
 - ALL PLANTS SHALL BE SET SO THAT, WHEN SETTLED, THEY BEAR THE SAME RELATION TO THE REQUIRED GRADE AS THEY BORE TO THE NATURAL GRADE BEFORE BEING TRANSPLANTED.
 - IMMEDIATELY AFTER PLANTING, STAKE ALL TREES WITH 3 CEDAR STAKES PER TREE.
 - PREPARE RAISED EARTH SAUCER AS WIDE AS PLANTING HOLE OF EACH PLANT.
 - WATER IMMEDIATELY AFTER PLANTING. WATER SHALL BE APPLIED TO EACH TREE AND SHRUB IN SUCH MANNER AS NOT TO DISTURB BACKFILL, AND TO THE EXTENT THAT ALL MATERIALS IN THE PLANTING HOLE ARE THOROUGHLY SATURATED.
 - AFTER SHRUB BEDS AND TREE SAUCERS ARE BACKFILLED AND FINE GRADED, APPLY "PREEN" WEED CONTROL BEFORE MULCHING WITH 3" DEPTH OF DARK, SHREDDED HARDWOOD BARK MULCH.
- FINISH GRADING**
 - PLUS/MINUS .1 FOOT OF FINISH GRADE.
 - ALL LAWN AND PLANTING AREAS SHALL BE GRADED TO A SMOOTH, EVEN UNIFORM PLANE WITH NO ABRUPT CHANGE OF SURFACE. SOIL AREAS ADJACENT TO THE BUILDING SHALL SLOPE AWAY FROM THE BUILDING.
 - ALL PLANTING AREAS SHALL BE GRADED AND MAINTAINED TO ALLOW FREE FLOW OF SURFACE WATER.
- GUARANTEE**
 - CONTRACTOR SHALL GUARANTEE ALL PLANTS FOR A PERIOD OF ONE (1) YEAR.
- CLEAN-UP**
 - UPON THE COMPLETION OF ALL PLANTING WORK AND BEFORE FINAL ACCEPTANCE, THE CONTRACTOR SHALL REMOVE ALL MATERIAL, EQUIPMENT, AND DEBRIS RESULTING FROM HIS WORK. ALL ACCEPTABLE CONDITIONS AS APPROVED BY THE OWNERS AUTHORIZED REPRESENTATIVE.
- MAINTENANCE**
 - MAINTENANCE PERIOD TO COMMENCE AFTER FINAL INSPECTION.
 - MAINTENANCE PERIOD FOR THIS CONTRACT SHALL BE 90 CALENDAR DAYS COMMENCING AFTER FINAL INSPECTION OF CONSTRUCTION. MAINTAIN TREES, SHRUBS AND OTHER PLANTS BY PRUNING, CULTIVATING AND WEEDING AS REQUIRED FOR HEALTHY GROWTH. RESTORE PLANTING SAUCERS, TIGHTEN AND REPAIR STAKE AND GUY SUPPORTS AND RESET RESET TREES AND SHRUBS TO PROPER GRADES OR VERTICAL POSITION AS REQUIRED. SPRAY AS REQUIRED TO KEEP TREES AND SHRUBS FREE OF INSECTS AND DISEASE. MAINTAIN LAWNS BY WATERING, FERTILIZING, WEEDING, MOWING, TRIMMING, AND OTHER OPERATIONS SUCH AS ROLLING, REGRADING AND REPLANTING AS REQUIRED TO ESTABLISH A SMOOTH, ACCEPTABLE LAWN, FREE OF ERODED OR BARE AREAS.
 - MAINTENANCE (ALTERNATE BID)
 - COST PER MONTH AFTER INITIAL 90 DAY MAINTENANCE PERIOD.

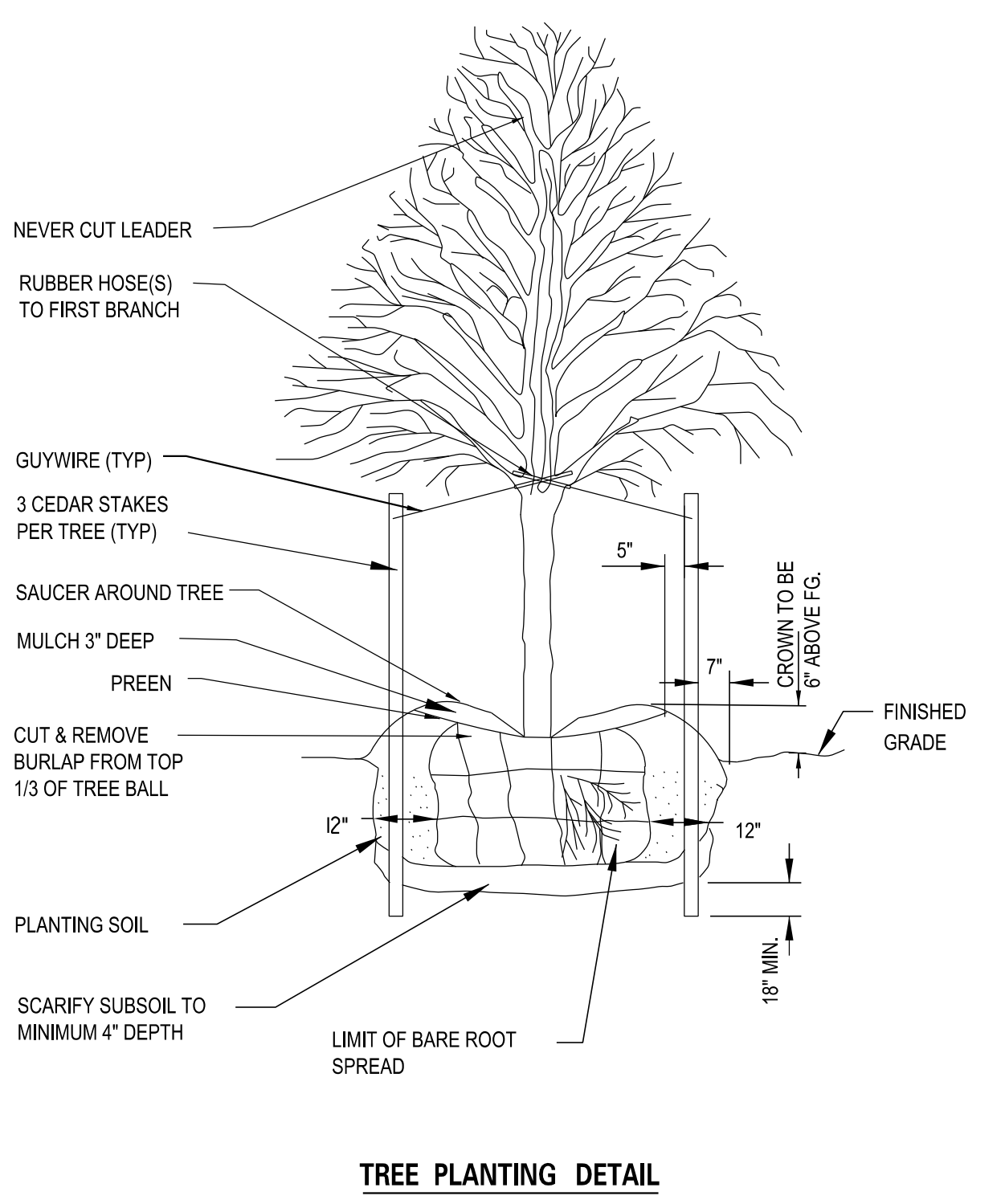

TREE SURVEY

SIZE/SPECIES	QTY. TO BE REMOVED	QTY. PROPOSED
4" POPLAR	30	0
6" POPLAR	15	0
8" POPLAR	7	0
8" MAPLE	1	0
5-6" COLORADO SPRUCE	0	21
2.5" NORWAY MAPLE	0	11
BIORETENTION TREES	0	22 MIN.
TOTAL	54	54 MIN.

- NOTE:**
- SEE DEMOLITION PLAN FOR REMOVAL OF TREES.
 - BIORETENTION PLANTINGS TO BE DETERMINED AFTER STORMWATER DESIGN IS FINALIZED.

PLANTING LIST (BY OTHERS)

KEY	QTY.	BOTANICAL NAME	COMMON NAME	MIN. SIZE
PP	21	PICEA PUNGENS	COLORADO SPRUCE	5-6' FULL TO GROUND
AP	11	ACER PLATANOIDES	NORWAY MAPLE	2 1/2" CAL.

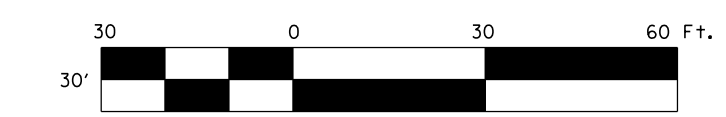



Town of Cheektowaga

Regular Meeting

~ Minutes ~

3301 Broadway
Cheektowaga, NY 14227

<http://www.town.cheektowaga.ny.us>

Alice Magierski
716-686-3400

Monday, June, 20, 2011

6:45 PM

Council Chambers

I. Call to Order

6:45 PM Meeting called to order on June 20, 2011 at Council Chambers, 3301 Broadway St, Cheektowaga, NY.

Attendee Name	Organization	Title	Status	Arrived
Mary Holtz	Town of Cheektowaga	Supervisor	Present	
Patricia Jaworowicz	Town of Cheektowaga	Councilmember	Present	
Jeff Swiatek	Town of Cheektowaga	Councilmember	Present	
James Rogowski	Town of Cheektowaga	Councilmember	Present	
Richard Zydel	Town of Cheektowaga	Councilmember	Present	
Charles Markel	Town of Cheektowaga	Councilmember	Present	
Stanley Kaznowski	Town of Cheektowaga	Councilmember	Present	

2. Additional Attendees

Thomas Adamczak, Supervising Building and Plumbing Inspector
Ellen Fischer, Executive Director - Youth Board
Brian Krause, Director of Finance and Administration
John Marriott, Planning Board Chairman
William Pugh, Town Engineer
Kevin Schenk, Town Attorney
David Zack, Chief of Police

II. Public Hearings

1. Rezoning of 2480 and Part of 2490-2550 Walden Avenue from M1- Light Manufacturing to CM-General Commercial

This being the time and place advertised for a Public Hearing, the Supervisor directed the Town Clerk to present that such notice has been duly published and posted; upon the order of the Supervisor such proof was duly filed.

The Supervisor announced that the Town Board would hear all persons interested in the subject of the hearing. Comments were heard, after which the Supervisor declared the hearing closed, decision was reserved.

RESULT: CLOSED [UNANIMOUS]
MOVER: James Rogowski, Councilmember
SECONDER: Stanley Kaznowski, Councilmember
AYES: Holtz, Jaworowicz, Swiatek, Rogowski, Zydel, Markel, Kaznowski

III. Public Comment Period

IV. Resolutions



1. RESOLUTION 2011-343

Transfer of Funds

Sponsored By: Supervisor Holtz, Councilmember Swiatek

BE IT RESOLVED, that the following transfer is hereby approved and made a part hereof;

HUD NYS AFFORDABLE HOUSING

FROM: 900.8600.4910 NYS AHC Revenues \$ 100,000.00

TO: 900.8668.4008 Loans from Program \$ 100,000.00

RESULT: ADOPTED [UNANIMOUS]

MOVER: Mary Holtz, Supervisor

SECONDER: Jeff Swiatek, Councilmember

AYES: Holtz, Jaworowicz, Swiatek, Rogowski, Zydel, Markel, Kaznowski



2. RESOLUTION 2011-344

Warrant

Sponsored By: Supervisor Holtz, Councilmember Swiatek

BE IT RESOLVED, that the following Vouchers & Warrants submitted to the Town of Cheektowaga prior to June 17, 2011 are hereby approved and made a part hereof;

GENERAL FUND	\$ 2,656,123.40
RISK RETENTION FUND	141,028.89
HUD HOUSING REHABILITATION FUND	476.00
SPECIAL DISTRICTS FUND	3,740,697.08
HIGHWAY FUND	518,352.53
CAPITAL FUND	204,080.93
TRUST & AGENCY FUND	2,595.00
HUD CDBG FUND	15,933.19
PART TOWN FUND	95,641.84
	<u>\$ 7,374,928.86</u>

RESULT:	ADOPTED [UNANIMOUS]
MOVER:	Mary Holtz, Supervisor
SECONDER:	Jeff Swiatek, Councilmember
AYES:	Holtz, Jaworowicz, Swiatek, Rogowski, Zydel, Markel, Kaznowski



3. RESOLUTION 2011-345

Award of Bid - One (1) New and Unused Flameless Pothole Patcher

Sponsored By: Councilmember Swiatek, Supervisor Holtz

WHEREAS, bids were received and opened by the Town Clerk at a public bid opening held on June 15, 2011 for One (1) New and Unused Flameless Pothole Patcher for use by the Town of Cheektowaga Highway Department as a result of advertisement thereof, and such bid was referred to the Superintendent of Highway for analysis, tabulation and reports, AND

WHEREAS, bids were analyzed and completed, NOW THEREFORE BE IT

RESOLVED, that there was only one bidder for One (1) New and Unused Flameless Pothole Patcher be awarded to Cyncon Equipment, Inc., 7494 West Henrietta Road, Rush, New York 14543 at a total bid price of \$86,842.00 said bidder meeting specifications of bid. AND, BE IT FURTHER

RESOLVED, that monies be charged to line items 300-5130-2407.

RESULT:	ADOPTED [UNANIMOUS]
MOVER:	Jeff Swiatek, Councilmember
SECONDER:	Mary Holtz, Supervisor
AYES:	Holtz, Jaworowicz, Swiatek, Rogowski, Zydel, Markel, Kaznowski



4. RESOLUTION 2011-346

Award of Bid for Demolition of 24E Glenwood Court

Sponsored By: Councilmember Markel, Councilmember Kaznowski

WHEREAS, bids were advertised for the demolition with asbestos abatement of a single-family residential unit at 24E Glenwood Court; and

WHEREAS, bid proposals were received and opened on June 15, 2011 for said demolition; and

WHEREAS, the proposals were reviewed by the Town Attorney and, based on proposals submitted, the Town Attorney has recommended that this Town Board award the bid for the demolition of the property located at 24E Glenwood Court to Metro Contracting & Environmental, Inc.; NOW, THEREFORE, BE IT

RESOLVED, that this Town Board hereby awards the bid for the demolition (controlled) of 24E Glenwood Court, Cheektowaga, New York to:

Metro Contracting & Environmental, Inc..
2939 Lockport Road
Niagara Falls, New York 14305-2307

for the bid price of \$16,000.00, being the lowest responsible bid meeting specifications, and BE IT FURTHER

RESOLVED, that the Supervisor be and hereby is directed to execute an agreement with Metro Contracting & Environmental, Inc., for the aforesaid services, and BE IT FURTHER

RESOLVED, that moneys for said services shall be appropriated from budget line item number 0800-800-0440.

RESULT:	ADOPTED [UNANIMOUS]
MOVER:	Charles Markel, Councilmember
SECONDER:	Stanley Kaznowski, Councilmember
AYES:	Holtz, Jaworowicz, Swiatek, Rogowski, Zydel, Markel, Kaznowski



5. RESOLUTION 2011-347

Award of Bid for Demolition of 27 Alpine Place

Sponsored By: Councilmember Markel, Councilmember Kaznowski

WHEREAS, bids were advertised for the demolition with asbestos abatement of a two-family residential structure at 27 Alpine Place; and

WHEREAS, bid proposals were received and opened on June 15, 2011 for said demolition; and

WHEREAS, the proposals were reviewed by the Town Attorney and, based on proposals submitted, the Town Attorney has recommended that this Town Board award the bid for the demolition of the property located at 27 Alpine Place to Metro Contracting & Environmental, Inc.; NOW, THEREFORE, BE IT

RESOLVED, that this Town Board hereby awards the bid for the demolition with asbestos abatement of 27 Alpine Place, Cheektowaga, New York to:

Metro Contracting & Environmental, Inc..
2939 Lockport Road
Niagara Falls, New York 14305-2307

for the bid price of \$38,000.00, being the lowest responsible bid meeting specifications, and BE IT FURTHER

RESOLVED, that the Supervisor be and hereby is directed to execute an agreement with Metro Contracting & Environmental, Inc., for the aforesaid services, and BE IT FURTHER

RESOLVED, that moneys for said services shall be appropriated from budget line item number 0800-800-0440.

RESULT:	ADOPTED [UNANIMOUS]
MOVER:	Charles Markel, Councilmember
SECONDER:	Stanley Kaznowski, Councilmember
AYES:	Holtz, Jaworowicz, Swiatek, Rogowski, Zydel, Markel, Kaznowski



6. RESOLUTION 2011-348

Issue Negative SEQR Declaration- 83 and Part of 61 Anderson Road

Sponsored By: Councilmember Rogowski, Councilmember Markel

WHEREAS, pursuant to the Environmental Impact Review Ordinance of the Town of Cheektowaga, the Environmental Advisory Committee ("EAC") reviews various applications for site plans, rezonings, special permits, etc. and renders its recommendation concerning the environmental significance of such application, AND

WHEREAS, the Town Board, pursuant to the Environmental Impact Review Ordinance of the Town of Cheektowaga, is designated the Lead Agency in most instances, AND

WHEREAS, since the Town Board is the Lead Agency, it must affirm, modify or reject any recommendations submitted to it by the Advisory Committee, AND

WHEREAS, an application was submitted by Jonathan E. Bennett, Architect for the Owner, Kabir Group, Inc. and LEE DEE & Sons, LLC for the rezoning of 83 Anderson and a part of 61 Anderson from M2- General Manufacturing to CM- General Commercial for the construction of a (5) five story, (88) eighty-eight room hotel and a (4) four story (50) fifty room hotel, AND

WHEREAS, the Environmental Advisory Committee at its meetings held on June 1, 2011 recommended a determination of non-significance and further recommends that no site disturbances occur on premises until such time that the owner prepares a phase two environmental audit and remediates any discovered contaminants, AND

WHEREAS, the project requires area variances from the Cheektowaga Zoning Board of Appeals for the height of the hotels and building setback along the westerly property line, AND

WHEREAS, the Town of Cheektowaga Planning Board recommended approval of the rezoning request at their meeting of April 14, 2011 and recommended the approval of the site plan at their meeting of June 9, 2011, AND

WHEREAS, this Town Board has reviewed the application submitted and the recommendations made by the Environmental Advisory Committee, and the Planning Board NOW, THEREFORE, BE IT

RESOLVED, that this Town Board determines that the project will not have a significant effect on the environment and therefore issues a Negative Declaration for purposes of SEQRA, AND BE IT

FURTHER RESOLVED, the proposed site plan is found to be acceptable subject to :

1. The Town Engineer reviewing and approving the grading and drainage plan.
2. The easterly portion of the site (phase two) being converted to vegetation during the construction of phase one.

3. The Cheektowaga Zoning Board of Appeals grants the necessary area variances.

Attachments:

Site Plan and Architectural Rendering (PDF)

RESULT: ADOPTED [UNANIMOUS]

MOVER: James Rogowski, Councilmember

SECONDER: Charles Markel, Councilmember

AYES: Holtz, Jaworowicz, Swiatek, Rogowski, Zydel, Markel, Kaznowski



7. RESOLUTION 2011-349

Approve Rezoning of 83 Anderson Road and Part of 61 Anderson Road

Sponsored By: Councilmember Markel, Councilmember Kaznowski

WHEREAS, Jonathan E. Bennett Architecture, P.C. petitioned for a rezoning from M2-General Manufacturing District to CM-General Commercial District for property owned by The Kabir Group, LLC and Lee Dee & Sons, LLC and located at 83 Anderson Road and Part of 61 Anderson Road, Cheektowaga, New York, which property is described in the attached legal description, for the construction of a five (5) story, 88-room hotel, and a four (4) story, 50-room hotel, and

WHEREAS, a public hearing on such petition was held before this Town Board on the 16th day of May, 2011 at 6:30 P.M., after publication and service of the notices required by the provisions of the Code of the Town of Cheektowaga ("Zoning Law"), and the Town Law; and all interested parties were given an opportunity to be heard at such hearing, and

WHEREAS, the Cheektowaga Planning Board has reviewed such application and has recommended approval thereof, and

WHEREAS, this Town Board previously issued a Negative Declaration under SEQRA and the Town Environmental Impact Review Ordinance for this rezoning, NOW, THEREFORE, BE IT

RESOLVED, that the application of Jonathan E. Bennett Architecture, P.C. for the rezoning from M2-General Manufacturing District to CM-General Commercial District of the property described in the attached legal description be and the same is hereby approved, subject to the following conditions:

1. The Zoning Board of Appeals granting the necessary area variance(s)
2. Any future additions/changes to the development or site plan area must be resubmitted to this Town Board to determine that the addition/change is substantially in agreement with the intent of the rezoning;
3. Unless application for a building permit for this property is made within a period of one (1) year after this Board's approval, said approval shall be void and the zoning classification shall be as it was when the petition for rezoning was filed,

and BE IT FURTHER

RESOLVED, that the Zoning Map and Law of the Town Of Cheektowaga be amended in accordance with the above.

LEGAL DESCRIPTION

ALL THAT TRACT OR PARCEL OF LAND, situate in the Town of Cheektowaga, County of Erie, and State of New York, being part of Lot 24, Township 11, Range 7 of the Holland Land Company's Survey, being more particularly described as follows:

BEGINNING a point in the centerline of Anderson Road (60' wide) distant 730.75 feet northerly from its intersection with the centerline of Dale Road, formerly known as Walden Avenue (66' wide), said centerline also being the centerline of a private road (100' wide) extending from Old Walden Avenue; thence northerly along the said centerline of Anderson Road, a distance of 68.25 feet to a point; thence easterly at an interior angle of 90° 00' 00", a distance of 122.00 feet to a point; thence southerly at an interior angle of 90° 00' 00", a distance of 68.25 feet to a point; thence westerly at an interior angle of 90° 00' 00", a distance of 122.00 feet to the point or place of beginning, containing 8,326 +/-square feet or 0.19 acre of land more or less.

ALSO, ALL THAT TRACT OR PARCEL OF LAND, situate in the Town of Cheektowaga, County of Erie, and State of New York, being part of Lot 24, Township 11, Range 7 of the Holland Land Company's Survey, being more particularly described as follows:

BEGINNING a point in the centerline of Anderson Road (60' wide) distant 799.00 feet northerly from its intersection with the centerline of Dale Road, formerly known as Walden Avenue (66' wide), said centerline also being the centerline of a private road (100' wide) extending from Old Walden Avenue; thence northerly along the said centerline of Anderson Road, a distance of 150.00 feet to a point; thence easterly at an interior angle of 90° 00' 00", a distance of 412.46 feet to a point; thence southerly at an interior angle of 90° 00' 00", a distance of 150.00 feet to a point; thence westerly at an interior angle of 90° 00' 00", a distance of 412.46 feet to the point or place of beginning, containing 61,869 +/-square feet or 1.42 acres of land more or less.

ALSO, ALL THAT TRACT OR PARCEL OF LAND, situate in the Town of Cheektowaga, County of Erie, and State of New York, being part of Lot 24, Township 11, Range 7 of the Holland Land Company's Survey, being more particularly described as follows:

COMMENCING a point in the centerline of Anderson Road (60' wide) distant 799.00 feet northerly from its intersection with the centerline of Dale Road, formerly known as Walden Avenue (66' wide), said centerline also being the centerline of a private road (100' wide) extending from Old Walden Avenue; thence easterly at an angle of 90° 00' 00" to the said centerline of Anderson Road, a distance of 412.46 feet to the POINT OF BEGINNING; thence northerly at an interior angle of 90° 00' 00", a distance of 150.00 feet to a point; thence easterly at an interior angle of 90° 00' 00", a distance of 216.99 feet to a point; thence southerly at an interior angle of 90° 00' 00", a distance of 150.00 feet to a point; thence westerly at an interior angle of 90° 00' 00", a distance of 216.99 feet to the point or place of beginning, containing 32,548 +/-square feet or 0.75 acre of land more or less.

RESULT:	ADOPTED [UNANIMOUS]
MOVER:	Charles Markel, Councilmember
SECONDER:	Stanley Kaznowski, Councilmember
AYES:	Holtz, Jaworowicz, Swiatek, Rogowski, Zydel, Markel, Kaznowski



8. RESOLUTION 2011-350

Call for Public Hearing - 4989 Genesee St.

Sponsored By: Councilmember Markel, Councilmember Rogowski

WHEREAS, 81 & 3 of Florida, Inc. with the permission of the Owner, Fudoli Revocable Trust Ralph has made application and requested the rezoning of 4989 Genesee Street from CM- General Commercial and R- Residence to RA - Apartment District for the construction of an eighty four (84) unit apartment complex, NOW, THEREFORE BE IT

RESOLVED, that a Public Hearing be held regarding said request under the provisions of the Zoning Law on July 5, 2011 at 6:45 P.M., at the Cheektowaga Town Hall, 3301 Broadway at the corner of Union Road.

Notice of Public Hearing

NOTICE IS HEREBY GIVEN that a Public Hearing will be held by the Town Board of the Town of Cheektowaga, Erie County, New York at the Town Hall in the said Town of Cheektowaga, 3301 Broadway corner of Union Road on the 5th day of July, 2011 at 6:45 o'clock P.M., of said day for the purpose of considering the application of:

81 & 3 of Florida, Inc.

for the rezoning of 4989 Genesee Street from CM- General Commercial and R- Residence to RA - Apartment District for the construction of an eighty four (84) unit apartment complex.

All parties in interest and citizens will be given an opportunity to be heard in regard to such proposed application.

BY ORDER OF THE TOWN BOARD, Town of Cheektowaga, NY

Alice Magierski, TOWN CLERK

LEGAL DESCRIPTION

All That Tract or Parcel of Land situate in the Town of Cheektowaga. County of Erie and Stale of New York, being part of Lot No. 75, Township 11 range 7 of the Holland Land Company's Survey and more particularly bounded and described as follows:

Beginning at a point on the South line of Genesee Street, said point also being distant 1.507,38 feet Westerly from the center line of Transit Road as measured along the South line of Genesee Street;

Course#1: Thence southerly along a line drawn parallel with the West line of said Lot No. 75 and also along the East line of the lands so conveyed to said Schmukal. 1110.26 feet to a point; Six courses Easterly along a wetland buffer line describe as follow:

Course#2: Thence Easterly along a line forming an interior angle of $54^{\circ} 54' 57''$, a distance of 95.79 feet to a point;

Course#3: Continuing Easterly along a line forming an exterior angle of $110^{\circ} 24' 33''$, a distance of 138.53 feet to a point;

Course#4: Continuing Easterly along a line forming an exterior angle of $137^{\circ} 20' 31''$, a distance of 75.64 feet to a point;

Course#5: Continuing Easterly along a line forming an interior angle of $150^{\circ} 34' 12''$, a distance of 32.21 feet to a point;

Course#6: Continuing Easterly along a line forming an exterior angle of $171^{\circ} 33' 19''$, a distance of 57.30 feet to a point;

Course#7: Continuing Easterly along a line forming an interior angle of $156^{\circ} 59' 28''$, a distance of 17.01 feet to a point on easterly of land;

Course#8: Thence Northerly in a straight line to a point, said point being distant 472.60 from the south line of Genesee Street, and 500.00 feet from South line of Genesee Street as a former 66" road.

Course#9: Thence westerly along a line parallel with Genesee Street a distance of 135.00 feet to a point

Course#10: Thence Northerly in a straight line to a point on the Southerly line of said Genesee Street distant 167.68 feet Easterly from the point of beginning

Course#11: Thence Westerly along the Southerly line Genesee Street, 167.68 feet to the point or place of beginning

Containing 6.2 acres more or less.

RESULT:	ADOPTED [UNANIMOUS]
MOVER:	Charles Markel, Councilmember
SECONDER:	James Rogowski, Councilmember
AYES:	Holtz, Jaworowicz, Swiatek, Rogowski, Zydel, Markel, Kaznowski



9. RESOLUTION 2011-351

Notice to Bidders - Boring of a 21" Sanitary Sewer

Sponsored By: Councilmember Kaznowski, Councilmember Zydel

WHEREAS, it is in order that bids be advertised for the Boring of a 21" Sanitary Sewer under Dick Road/North Creek Drive, NOW, THEREFORE, BE IT

RESOLVED, that the Town Clerk be directed to publish a Notice to Bidders for the Boring of a 21" Sanitary Sewer under Dick Road/North Creek Drive, said notice to be published in the CHEEKTOWAGA BEE, AND, BE IT FURTHER

RESOLVED, that sealed bids will be received on the 6th day of July, 2011 at 11:00 a.m. at a public bid opening to be held in the Council Chambers in the Cheektowaga Town Hall.

NOTICE TO BIDDERS

NOTICE IS HEREBY GIVEN that sealed proposals will be received and considered by the Town Board of the Town of Cheektowaga, County of Erie, State of New York, on the 6th day of July, 2011 at 11:00 a.m., local time, in the Town Hall, Town of Cheektowaga, New York for furnishing all labor, tools, equipment, materials and incidentals required for the Boring of a 21" Sanitary Sewer Culvert Under Dick Road, complete, in place and ready for use in accordance with the contract documents, therefore, including Plans, Specifications, Instructions to Bidders, etc. and approved by the Town Board of the Town of Cheektowaga, all of which are on file with the Town Engineer in his office at 275 Alexander Avenue, Cheektowaga, New York 14211.

Copies of the proposed Contract Documents, Plans, Specifications and Instructions to Bidders may be examined at the Town of Cheektowaga Engineering Department, 275 Alexander Avenue, Cheektowaga, New York 14211 and at the Town Clerk's Office, Broadway & Union Road, Cheektowaga, New York 14227. Copies may be secured at the Office of the Town Clerk upon payment of \$50.00 per set of documents by check made payable to the Town of Cheektowaga.

Any bidder returning such Plans and Specifications in good condition within 30 days following the award of the contract or the rejection of the bids will be refunded the full amount of the deposit. Similarly, non-bidders will be refunded one-half the deposit. Material suppliers and anyone returning the Plans and Specifications before the bid opening will also be classed as non-bidders. Any bidders requesting more than one set of Plans and Specifications may purchase the excess but it is understood that they are not returnable.

All bids must be enclosed in a separate, sealed envelope and shall be addressed to the Town Clerk of the Town of Cheektowaga, Town Hall, Broadway & Union Roads, Cheektowaga, New York 14227 and marked "Boring of a 21" Sanitary Sewer Under Dick Road".

The right to reject any and all bids, to waive any informalities in, or to make an award to other than the low bidder, should it be deemed to be in the best interest of the Town of Cheektowaga and in accordance with the law, are herewith reserved.

Each proposal must be accompanied by a certified check for a sum equal to five percent (5%) of the amount of the bid, payable to the Town of Cheektowaga, New York, or bid bond with sufficient sureties to be approved by the Attorney for the Town of Cheektowaga, New York, in a sum equal to five percent (5%) of the amount of the bid, conditioned that, if his proposal is accepted, he will enter into a contract for the same and that he will execute such further security as may be required for the faithful performance of the Contract.

No bidder may withdraw his bid within forty-five days after the date set for the opening thereof but may withdraw same any time prior to the scheduled date for the opening of bids.

The successful bidder will be required to furnish a Performance Bond and Labor and Material Bond acceptable to the Owner in an amount equal to the contract award.

Attention of the bidders is further called to Section 103-d of the General Municipal Law which requires a bidder's Certificate of Non-Collusion. Such certificate is part of the bid or proposal form and unless complied with, such bid will not be accepted.

The Town of Cheektowaga is an exempt organization under the Tax Law and is exempt from payment of sales and compensating use taxes in the State of New York and cities and counties of the State on all materials which are to be incorporated into the project, pursuant to the provisions of the Contract. These taxes are not to be included in the bid.

The work shall be completed within 90 consecutive calendar days, to begin five days after the "Order to Commence Work" has been issued.

BY ORDER OF: THE TOWN OF CHEEKTOWAGA

Alice Magierski, Town Clerk

DATED: June 20, 2011

RESULT:	ADOPTED [UNANIMOUS]
MOVER:	Stanley Kaznowski, Councilmember
SECONDER:	Richard Zydel, Councilmember
AYES:	Holtz, Jaworowicz, Swiatek, Rogowski, Zydel, Markel, Kaznowski



10. RESOLUTION 2011-352

Accept Site Plan - 3600 Genesee Street - Keller Chevrolet

Sponsored By: Councilmember Markel, Councilmember Rogowski

WHEREAS, pursuant to the Zoning Law of the Town of Cheektowaga, the Planning Board reviews various development review applications for site plans, rezonings, special permits and realty subdivisions and renders its recommendation concerning the compatibility of such application with the zoning regulations, Town Master Plan and neighborhood character, AND

WHEREAS, the Town Board, pursuant to the Zoning Law of the Town of Cheektowaga, is required to affirm, modify or reject any recommendation submitted to it by the Planning Board, AND

WHEREAS, a development review application and site plan was submitted by Dean Sutton Architects, LLP for the construction of a 2,200 square foot building addition to an existing automobile dealership at 3600 Genesee Street, AND

WHEREAS, the Town of Cheektowaga Planning Board at its meeting of May 12, 2011 is recommending the approval of the site plan, AND

WHEREAS, the Cheektowaga Zoning Board of Appeals received a request for an area variance for the building setback, AND

WHEREAS, this Town Board has reviewed the development review application and recommendations made by the Planning Board, NOW THEREFORE, BE IT

RESOLVED, that this Town Board determines that the project site plan is acceptable subject to :

1. The Town Engineer reviewing and approving a grading/drainage plan.
2. The Zoning Board of Appeals granting the necessary area variance.

Attachments:

Keller Chevrolet_ Site Plan (PDF)

RESULT:	ADOPTED [UNANIMOUS]
MOVER:	Charles Markel, Councilmember
SECONDER:	James Rogowski, Councilmember
AYES:	Holtz, Jaworowicz, Swiatek, Rogowski, Zydel, Markel, Kaznowski



11. RESOLUTION 2011-353

Approve Purchase of One (1) 2012 Freightliner M2-106 Single Axle Cab & Chassis

Sponsored By: Councilmember Swiatek, Supervisor Holtz

WHEREAS, the Highway Department, have requested authorization to purchase One (1) 2012 Freightliner M2-106 Single Axle Cab and Chassis, as specified in New York State OGS Contracts PC62756, AND

WHEREAS, funds for said purchase have been budgeted and are available under account number 300-5130-2407, NOW, THEREFORE BE IT,

RESOLVED, that the Town Board hereby authorizes the purchase of One (1) 2012 Freightliner M2-106 Single Axle Cab and Chassis in the amount of \$65,474.15 from:

Fleet maintenance, Inc.
67 Ransier Drive
West Seneca, NY 14224

RESULT:	ADOPTED [UNANIMOUS]
MOVER:	Jeff Swiatek, Councilmember
SECONDER:	Mary Holtz, Supervisor
AYES:	Holtz, Jaworowicz, Swiatek, Rogowski, Zydel, Markel, Kaznowski



12. RESOLUTION 2011-354

Approve 2011 Funding for Cheektowaga Cultural Society and Cheektowaga Art Guild

Sponsored By: Councilmember Rogowski, Councilmember Zydel

WHEREAS, the Town, in its 2011 budget, allocated moneys to certain cultural and not-for-profit organizations which are involved in activities which benefit the Town, and

WHEREAS, agreement(s) between the Town and these cultural and not-for-profit organizations have been prepared and forwarded to such groups, and

WHEREAS, the organization(s) listed below have completed and returned signed agreement(s) and their accounting report(s) from the 2010 funding to the Town, NOW, THEREFORE, BE IT

RESOLVED, that this Town Board hereby approves agreement(s) with the cultural and not-for-profit organization(s) listed below for the amount(s) listed, and BE IT FURTHER

RESOLVED, that the Supervisor be and hereby is authorized and directed to execute agreement(s) with the following referenced cultural and not-for-profit organization(s) for the following respective amount(s):

<u>Cultural/Not-For-Profit Organization</u>	<u>Funding Approved</u>
Cheektowaga Cultural Society	\$ 3,150.00
Cheektowaga Art Guild	\$ 1,200.00

and BE IT FURTHER

RESOLVED, that the aforementioned moneys shall be paid to the respective cultural/not-for-profit organization(s) out of the respective cultural group budget line item(s) in the 2011 Town budget, subject to audit and approval of a properly signed Town voucher.

RESULT:	ADOPTED [UNANIMOUS]
MOVER:	James Rogowski, Councilmember
SECONDER:	Richard Zydel, Councilmember
AYES:	Holtz, Jaworowicz, Swiatek, Rogowski, Zydel, Markel, Kaznowski



13. RESOLUTION 2011-355

Authorize Supervisor to Execute Agreement with Verizon Wireless

Sponsored By: Supervisor Holtz, Councilmember Swiatek

WHEREAS, the Town of Cheektowaga is desirous of contracting with Verizon Wireless for the use of wireless devices in Town vehicles, and

WHEREAS, Verizon Wireless has submitted a proposal to the Town to provide these devices, NOW, THEREFORE, BE IT

RESOLVED, that the Supervisor be and hereby is authorized and directed to execute any and all documents with Verizon Wireless for the utilization of these devices, and BE IT FURTHER

RESOLVED, that funding for said devices shall be appropriated out of the following accounts:

100.5132.4432

300.5140.4191

Miscellaneous other town department accounts as appropriate

RESULT:	ADOPTED [UNANIMOUS]
MOVER:	Mary Holtz, Supervisor
SECONDER:	Jeff Swiatek, Councilmember
AYES:	Holtz, Jaworowicz, Swiatek, Rogowski, Zydel, Markel, Kaznowski



14. RESOLUTION 2011-356

Authorize Municipal Cooperation Agreements with Village of Sloan, Village of Depew and Town of Aurora

Sponsored By: Councilmember Swiatek, Supervisor Holtz

WHEREAS, the Village of Sloan, the Village of Depew and the Town of Aurora have requested that the Town of Cheektowaga Highway Department assist them in the paving of certain streets in said municipalities, and

WHEREAS, the Town of Cheektowaga Superintendent of Highways is willing to assist said municipalities as requested, and

WHEREAS, before the Town Superintendent of Highways can provide said services outside of the jurisdiction of the Town Highway District, the Town Board must authorize same, and

WHEREAS, Article 5-G of the General Municipal Law and Section 142-d of the Highway Law authorize this Town Board to enter into agreements with other municipalities to perform this work, NOW, THEREFORE, BE IT

RESOLVED, that the Supervisor be and hereby is authorized and directed to execute municipal cooperation agreements with the Village of Sloan, Village of Depew and Town of Aurora to pave designated streets in said municipalities, and BE IT FURTHER

RESOLVED, that moneys received from said municipalities for the provision of the requested services shall be deposited into the proper accounts as determined by the Director of Administration and Finance.

RESULT:	ADOPTED [UNANIMOUS]
MOVER:	Jeff Swiatek, Councilmember
SECONDER:	Mary Holtz, Supervisor
AYES:	Holtz, Jaworowicz, Swiatek, Rogowski, Zydel, Markel, Kaznowski



15. RESOLUTION 2011-357

Authorize Auction of Surplus Vehicles and Equipment

Sponsored By: Supervisor Holtz, Councilmember Markel

WHEREAS, the Town wishes to dispose of a number of surplus motor vehicles and equipment no longer needed for Town use: and

WHEREAS, sale of surplus property by the Town is authorized by Section 64 of the Town Law of the State of New York; and

WHEREAS, Auctions International, Inc., will sell such motor vehicles and equipment at an on-line auction in accordance with the terms of an agreement dated April 22, 2010, a copy of which is attached hereto; NOW THEREFORE, BE IT

RESOLVED, that the Town hereby retains Auctions International, Inc., 808 Borden Road, Cheektowaga, New York, in accordance with the attached agreement, to conduct a sale of the surplus Town vehicles and equipment identified on the attached list entitled "Auction - 2011 Vehicles and Equipment" at an on-line auction to be held on its website; and BE IT FURTHER

RESOLVED, that the Supervisor of the Town of Cheektowaga be and hereby is authorized to execute and any and all documents that may be required to effectuate the sale and transfer of said vehicles and equipment.

Attachments:

Auctions International Agreement 4.22.2010 (PDF)

Auction 2011 - Vehicles and Equipment (PDF)

RESULT: ADOPTED [UNANIMOUS]

MOVER: Mary Holtz, Supervisor

SECONDER: Charles Markel, Councilmember

AYES: Holtz, Jaworowicz, Swiatek, Rogowski, Zydel, Markel, Kaznowski



16. RESOLUTION 2011-358

Public Improvement Permit - 590 Duke Road (Derrick Corporation)

Sponsored By: Councilmember Zydel, Supervisor Holtz

WHEREAS, the Public Improvement Permit Ordinance of the Town of Cheektowaga requires that all public improvements which are to be dedicated to, and be maintained by the Town, be installed under a Public Improvement Permit, AND

WHEREAS, the developer of the proposed building expansion at 590 Duke Road has submitted plans and specifications and a Public Improvement Permit Application and permit fee for the replacement of 450 lineal feet of Town owned storm sewer and three (3) storm chambers under and adjacent to the proposed building and the installation of 785 lineal feet of concrete curbing, 352 lineal feet of storm sewers and three (3) catch basins, AND

WHEREAS, the Town Engineer has reviewed the plans and specifications of the subject improvements and finds said design acceptable, NOW, THEREFORE, BE IT

RESOLVED, that the Public Improvement Permit be and hereby is approved for the proposed highway and storm sewer improvements, AND, BE IT FURTHER

RESOLVED, that the permit fee in the amount of \$1,425.00 be deposited in the Public Improvement Permit Account which has been established for receipt and disbursement of such fees.

RESULT:	ADOPTED [UNANIMOUS]
MOVER:	Richard Zydel, Councilmember
SECONDER:	Mary Holtz, Supervisor
AYES:	Holtz, Jaworowicz, Swiatek, Rogowski, Zydel, Markel, Kaznowski



17. RESOLUTION 2011-359

Unsafe-Unsecured/11 Normandy Avenue

Sponsored By: Councilmember Markel, Councilmember Kaznowski

WHEREAS, Town of Cheektowaga Law for the Administration and Enforcement of the Codes of New York State; and the Property Maintenance Code of New York State require that all vacant structures and premises shall be maintained in clean, safe, secure and sanitary conditions so as not to cause a blighting problem or adversely affect the public health or safety and all nuisances abated, AND

WHEREAS, the Town of Cheektowaga has received notification of an unsafe structure and premises located at 11 Normandy Avenue, Cheektowaga, New York SBL# 102.21-1-20 that is a danger to the safety of others, and records kept by the Assessors Office identify Duncan Yelds, Genesis REI, LLC, 138 Culver Road, Rochester, New York 14609, as the owner AND

WHEREAS, an inspection of such premises was conducted at 11 Normandy Avenue, by the Housing and Neighborhood Preservation Office, AND

WHEREAS, such inspection found the premises to be deteriorated, vacant, a hazard, and a danger to the safety and well being of others, AND

WHEREAS, the Town of Cheektowaga Housing and Neighborhood Preservation Office properly notified the property owner in accordance with the Town of Cheektowaga Law for the Administration and Enforcement of the Codes of New York State, and the owner failed to take actions to safeguard the premises, AND

WHEREAS, these conditions require the Town of Cheektowaga Housing and Neighborhood Preservation Office to take immediate steps to safeguard the premises to protect the health and safety of others and abate all nuisances, NOW, THEREFORE BE IT

RESOLVED, that pursuant to Section 70-7A.(5) and Section 70-8 of the Town of Cheektowaga Law for the Administration and Enforcement of the Codes of New York State that the vacant structure premises be safeguarded and all nuisances abated; and all costs incurred be assessed against the property hereinbefore described

RESULT:	ADOPTED [UNANIMOUS]
MOVER:	Charles Markel, Councilmember
SECONDER:	Stanley Kaznowski, Councilmember
AYES:	Holtz, Jaworowicz, Swiatek, Rogowski, Zydel, Markel, Kaznowski



18. RESOLUTION 2011-360

Unsafe-Unsecured/15 Atwood Place

Sponsored By: Councilmember Markel, Councilmember Kaznowski

WHEREAS, Town of Cheektowaga Law for the Administration and Enforcement of the Codes of New York State; and the Property Maintenance Code of New York State require that all vacant structures and premises shall be maintained in clean, safe, secure and sanitary conditions so as not to cause a blighting problem or adversely affect the public health or safety and all nuisances abated, AND

WHEREAS, the Town of Cheektowaga has received notification of an unsafe structure and premises located at 15 Atwood Place, Cheektowaga, New York SBL# 90.84-1-4 that is a danger to the safety of others, and records kept by the Assessors Office identify Patrick, Sharon & Susan Schlicht, 262 Robert Drive, Apt. 6, N. Tonawanda, New York 14120, as the owner AND

WHEREAS, an inspection of such premises was conducted at 15 Atwood Place, by the Housing and Neighborhood Preservation Office, AND

WHEREAS, such inspection found the premises to be deteriorated, vacant, a hazard, and a danger to the safety and well being of others, AND

WHEREAS, the Town of Cheektowaga Housing and Neighborhood Preservation Office properly notified the property owner in accordance with the Town of Cheektowaga Law for the Administration and Enforcement of the Codes of New York State, and the owner failed to take actions to safeguard the premises, AND

WHEREAS, these conditions require the Town of Cheektowaga Housing and Neighborhood Preservation Office to take immediate steps to safeguard the premises to protect the health and safety of others and abate all nuisances, NOW, THEREFORE BE IT

RESOLVED, that pursuant to Section 70-7A.(5) and Section 70-8 of the Town of Cheektowaga Law for the Administration and Enforcement of the Codes of New York State that the vacant structure premises be safeguarded and all nuisances abated; and all costs incurred be assessed against the property hereinbefore described

RESULT:	ADOPTED [UNANIMOUS]
MOVER:	Charles Markel, Councilmember
SECONDER:	Stanley Kaznowski, Councilmember
AYES:	Holtz, Jaworowicz, Swiatek, Rogowski, Zydel, Markel, Kaznowski



19. RESOLUTION 2011-361

Approve Student Intern in Police Department

Sponsored By: Councilmember Jaworowicz, Councilmember Rogowski

WHEREAS, Jenna S. Hurley, a student at the University of Cincinnati (Criminal Justice Program), has requested to participate in the student internship program at the Cheektowaga Police Department, and

WHEREAS, Ms. Hurley has been interviewed by the Police Department and the Department is willing to afford her the opportunity to intern in the Police Department; NOW, THEREFORE, BE IT

RESOLVED, that Jenna S. Hurley and hereby is authorized to participate as an unpaid intern in the Cheektowaga Police Department, subject to her execution of a Waiver of Liability and Agreement of Confidentiality; and BE IT FURTHER

RESOLVED, that said internship shall not commence until proof of liability insurance from the University of Cincinnati is received and approved by the Town Attorney; and BE IT FURTHER

RESOLVED, that the Supervisor be and hereby is authorized and directed to execute the Agreement of Confidentiality and all other documents necessary to effectuate this student internship in the Police Department, subject to approval by the Town Attorney.

RESULT:	ADOPTED [UNANIMOUS]
MOVER:	Patricia Jaworowicz, Councilmember
SECONDER:	James Rogowski, Councilmember
AYES:	Holtz, Jaworowicz, Swiatek, Rogowski, Zydel, Markel, Kaznowski



20. RESOLUTION 2011-362

Approve Student Intern in Police Department

Sponsored By: Councilmember Jaworowicz, Councilmember Rogowski

WHEREAS, Janie Ross, a student at Erie County Community College, has requested to participate in the student internship program at the Cheektowaga Police Department, and

WHEREAS, Ms. Ross has been interviewed by the Police Department and the Department is willing to afford her the opportunity to intern in the Police Department; NOW, THEREFORE, BE IT

RESOLVED, that Janie Ross of Cheektowaga, New York be and hereby is authorized to participate as an unpaid intern in the Cheektowaga Police Department for the period June 21, 2011 to August 31, 2011, subject to her execution of a Waiver of Liability and Agreement of Confidentiality; and BE IT FURTHER

RESOLVED, that the Supervisor be and hereby is authorized and directed to execute the Agreement of Confidentiality, and all other documents necessary to effectuate this student internship in the Police Department.

RESULT:	ADOPTED [UNANIMOUS]
MOVER:	Patricia Jaworowicz, Councilmember
SECONDER:	James Rogowski, Councilmember
AYES:	Holtz, Jaworowicz, Swiatek, Rogowski, Zydel, Markel, Kaznowski



21. RESOLUTION 2011-363

Youth & Recreation Terminations

Sponsored By: Councilmember Zydel, Councilmember Rogowski

BE IT RESOLVED that the individuals listed below be and hereby are terminated in the Department of Youth & Recreational Services, effective as indicated:

Jacqueline Campbell	6/2/11	14043
Marissa Floyd	Never Worked	14215
Olivia Gmerek	Never Worked	14225
Kara Jeziorski	8/31/10	14227
Madalyn Lewis	Never Worked	14225
Steven Mazurkiewicz	8/31/10	14225
Nathan Meyers	Never Worked	14225
Alana Nguyen	Never Worked	14225
Jessica Ruda	Never Worked	14227
Korrey Williams	Never Worked	14227

Motion by Supervisor Holtz; Seconded by Councilmember Rogowski to Waive the Reading of Names for the Following three (3) resolutions: 2011-363; 2011-364 and 2011-365. Motion Carried

RESULT: ADOPTED [UNANIMOUS]
MOVER: Richard Zydel, Councilmember
SECONDER: James Rogowski, Councilmember
AYES: Holtz, Jaworowicz, Swiatek, Rogowski, Zydel, Markel, Kaznowski



22. RESOLUTION 2011-364

Youth & Recreation Hire/Transfers

Sponsored By: Councilmember Zydel, Councilmember Rogowski

BE IT RESOLVED that the individuals listed below be and hereby are hired and/or transferred, as indicated, in the Department of Youth & Recreational Services, effective immediately:

Recreation Attendant - \$7.50 - Camp Flamingo - 7310.1810 - Regular Part-time
Amanda Langa

Recreation Attendant - \$7.65 - Camp Crabapple- 7310.1802 Regular Part-time
Meggan Empric

Recreation Instructor - \$8.25 -Camp Crabapple- 7310.1802 Regular Part-time
Bryan Haxton

Recreation Instructor - \$9.25 - Camp JI-IK-DO-WAH-GAH - 7310.1801 Regular Part-time
Alex Ladowski

Recreation Specialist - \$14.15 - Camp Flamingo - 7310.1810 Regular Part-time
Amy McMahon

Recreation Instructor - \$8.75 - Camp Crabapple- 7310.1802 Regular Part-time
DeYonca Porter

Recreation Instructor- \$8.50 - Camp Flamingo - 7310.1810 - Regular Part-time
Kristen Stadelmeyer

Recreation Instructor - \$9.40 - Camp JI-IK-DO-WAH-GAH - 7310.1801 Regular Part-time
Maribeth Stadelmeyer

Recreation Attendant - \$7.80 - Camp JI-IK-DO-WAH-GAH - 7310.1801 Regular Part-time
Jessica Szyjka

Recreation Attendant - \$7.50 - Camp Crabapple- 7310.1802 - Seasonal
Shannon Kelly 14227

Recreation Attendant - \$7.25 - Camp JI-IK-DO-WAH-GAH - 7310.1801 Seasonal
Robert Strauss 14043

Recreation Attendant - \$7.65 - Camp Flamingo - 7310.1810 - Seasonal
Nicole Habermehl 14225

Recreation Attendant to Recreation Instructor - \$8.25 - 7310.1810 - Regular Part-time
Jennifer Laffrado 14225

Recreation Instructor to Recreation Attendant - \$8.50 - 7310.1810 - Regular Part-time
Mauren Szydowski

From Regular Part-time to Part-time - Lifeguard - 7180.1903

Erica Orlowski

From Lifeguard to Recreation Attendant -7140.1633 - \$8.76 - Regular Part-time

Matt Maciejewski

Recreation Aide - 7140.1611 - \$7.25 - Part-time

Daniel Urshel 14043

RESULT:	ADOPTED [UNANIMOUS]
MOVER:	Richard Zydel, Councilmember
SECONDER:	James Rogowski, Councilmember
AYES:	Holtz, Jaworowicz, Swiatek, Rogowski, Zydel, Markel, Kaznowski



23. RESOLUTION 2011-365

Hiring/Termination of Part-Time/Seasonal Employees

Sponsored By: Councilmember Swiatek, Supervisor Holtz

BE IT RESOLVED, that the following individuals be and hereby are hired as **SEASONAL EMPLOYEES**, not to exceed five (5) months in a calendar year, in the department listed and in compliance with Civil Service Laws and Regulations as well as the provisions of the Town's collective bargaining agreement between the Town of Cheektowaga and the Town of Cheektowaga Employees Association:

SANITATION DEPARTMENT Laborer \$8.00/hour effective 6/15/11

Gregory S. Pigeon, Cheektowaga, New York

Justin P. Borowski, Depew, New York

Bryan M. Kazmierczak, Cheektowaga, New York

Gary A. Slawiak, Sloan, New York

AND, BE IT FURTHER

RESOLVED, that the following seasonal and/or part-time employee be and hereby is terminated as listed:

POLICE DEPARTMENT (Sign Maintenance Division)

Daniel Clifford effective 6/6/11

RESULT:	ADOPTED [UNANIMOUS]
MOVER:	Jeff Swiatek, Councilmember
SECONDER:	Mary Holtz, Supervisor
AYES:	Holtz, Jaworowicz, Swiatek, Rogowski, Zydel, Markel, Kaznowski



24. RESOLUTION 2011-366

Creation of Twenty-Five (25) Recreation Aide (Part Time) Titles

Sponsored By: Councilmember Swiatek, Supervisor Holtz

BE IT RESOLVED, that this Town Board hereby create 25 (twenty-five) Recreation Aide (Part Time) positions pursuant to Civil Service Laws and Rules effective June 21, 2011.

RESULT:	ADOPTED [UNANIMOUS]
MOVER:	Jeff Swiatek, Councilmember
SECONDER:	Mary Holtz, Supervisor
AYES:	Holtz, Jaworowicz, Swiatek, Rogowski, Zydel, Markel, Kaznowski



25. RESOLUTION 2011-367

Creation of Senior Assessment Clerk Title

Sponsored By: Councilmember Swiatek, Supervisor Holtz

BE IT RESOLVED, that this Town Board hereby creates the position of Senior Assessment Clerk pursuant to Civil Service Laws and Rules effective June 21, 2011.

RESULT:	ADOPTED [UNANIMOUS]
MOVER:	Jeff Swiatek, Councilmember
SECONDER:	Mary Holtz, Supervisor
AYES:	Holtz, Jaworowicz, Swiatek, Rogowski, Zydel, Markel, Kaznowski



26. RESOLUTION 2011-368

Termination of Laborer (Highway Department/John G. Strong)

Sponsored By: Councilmember Swiatek, Supervisor Holtz

BE IT RESOLVED, that John G. Strong, a Laborer in the Highway Department be and hereby is terminated effective 5/16/11.

RESULT:	ADOPTED [UNANIMOUS]
MOVER:	Jeff Swiatek, Councilmember
SECONDER:	Mary Holtz, Supervisor
AYES:	Holtz, Jaworowicz, Swiatek, Rogowski, Zydel, Markel, Kaznowski



27. RESOLUTION 2011-369

Travel Authorization Police Department (Amendment)/Captain James Speyer

Sponsored By: Councilmember Jaworowicz, Councilmember Swiatek

WHEREAS, a Travel Authorization Request was approved by Town Board resolution on June 6, 2011; AND

WHEREAS, said resolution granted authorization to Captain James Speyer to attend the Workers Compensation Law and Practice seminar on July 20, 2011; AND

WHEREAS, said resolution erroneously stated that the seminar is being held in Atlantic City, New Jersey; AND

WHEREAS, the seminar is being held in Rochester, New York; NOW, THEREFORE, BE IT

RESOLVED, that Captain James Speyer be and hereby is authorized to attend the Workers Compensation Law and Practice seminar being held on July 20, 2011 in Rochester, New York.

RESULT:	ADOPTED [UNANIMOUS]
MOVER:	Patricia Jaworowicz, Councilmember
SECONDER:	Jeff Swiatek, Councilmember
AYES:	Holtz, Jaworowicz, Swiatek, Rogowski, Zydel, Markel, Kaznowski



28. RESOLUTION 2011-370

Travel Authorization Police Department/Police Officers Jacob Gawronski and Thomas Rogers

Sponsored By: Councilmember Jaworowicz, Councilmember Swiatek

WHEREAS, the Remington Armorer's School is being held August 16 through August 19, 2011 in Ilion, New York; AND

WHEREAS, Police Officers Jacob Gawronski and Thomas Rogers have requested authorization to attend said school; AND

WHEREAS, Police Chief David Zack has submitted a request for travel authorization along with the proper paperwork in a timely manner; AND

WHEREAS, the total cost to the Town shall not exceed \$2,870.76; AND

WHEREAS, these expenses have been budgeted by the Police Department; NOW, THEREFORE, BE IT

RESOLVED, that Police Officers Jacob Gawronski and Thomas Rogers be and hereby are authorized to attend the Remington Armorer's School being held August 16 through August 19, 2011 in Ilion, New York.

RESULT:	ADOPTED [UNANIMOUS]
MOVER:	Patricia Jaworowicz, Councilmember
SECONDER:	Jeff Swiatek, Councilmember
AYES:	Holtz, Jaworowicz, Swiatek, Rogowski, Zydel, Markel, Kaznowski

V. Communications

A. Departmental Communications

1. Supervisor's Statement of Funds - April 2011
2. Minutes: Cheektowaga Planning Board - May 12, 2011
3. Minutes: Cheektowaga Public Library - Board of Trustees - May 18, 2011
4. Minutes: Town Environmental Advisory Committee - June 1, 2011

B. General Communications

1. Notice of Claim: Norbert Beresniewicz Vs. Town of Cheektowaga
2. Notice of Claim: Kenneth Parker Vs. Town of Cheektowaga

VI. Comments

A. Supervisor's Comments

B. Councilmember's Comments

C. Public Comments

VII. Motion To: Adjournment

COMMENTS - Current Meeting:

Motion to adjourn the meeting at 8:10 PM.

Alice Magierski, Town Clerk

RESULT: ADOPTED [UNANIMOUS]

MOVER: Mary Holtz, Supervisor

SECONDER: Patricia Jaworowicz, Councilmember

AYES: Holtz, Jaworowicz, Swiatek, Rogowski, Zydel, Markel, Kaznowski

PROPOSED SUBDIVISION

ANDERSON ROAD, CHEEKTOWAGA, NEW YORK



1 EXTERIOR ELEVATION VIEW FROM ANDERSON ROAD

JONATHAN E. BENNETT ARCHITECTURE, P.C.
from inspiration to installation



104 Evans Street, Lockport, New York 14094
716-438-7940 office / 716-438-7255 fax
www.dcs-ae.com

CLIENT:
KABIR GROUP, INC. 3950 MCKINLEY PARKWAY
BLASDELL, NEW YORK

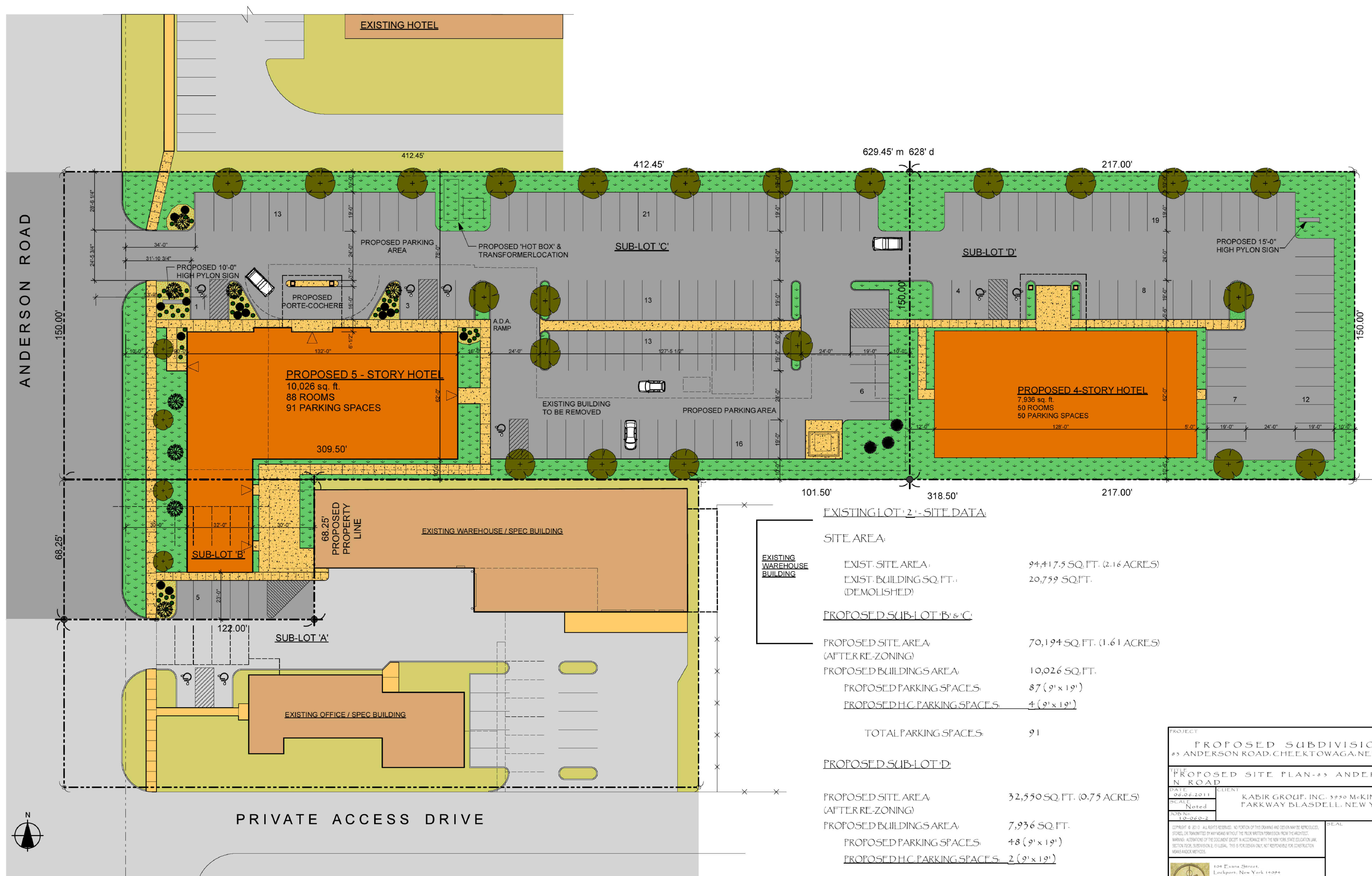

EXISTING LOT 2 - SITE DATA:

SITE AREA:	
EXIST. SITE AREA:	94,417.5 SQ. FT. (2.16 ACRES)
EXIST. BUILDING SQ. FT. (DEMOLISHED)	20,759 SQ. FT.

PROPOSED SUB-LOT 'B' & 'C':

PROPOSED SUB-LOT 'B' & 'C':	
PROPOSED SITE AREA (AFTER RE-ZONING)	70,194 SQ. FT. (1.61 ACRES)
PROPOSED BUILDINGS AREA:	10,026 SQ. FT.
PROPOSED PARKING SPACES:	87 (9' x 19')
PROPOSED H.C. PARKING SPACES:	4 (9' x 19')
TOTAL PARKING SPACES:	91

PROPOSED SUB-LOT 'D':

PROPOSED SUB-LOT 'D':	
PROPOSED SITE AREA (AFTER RE-ZONING)	32,550 SQ. FT. (0.75 ACRES)
PROPOSED BUILDINGS AREA:	7,936 SQ. FT.
PROPOSED PARKING SPACES:	48 (9' x 19')
PROPOSED H.C. PARKING SPACES:	2 (9' x 19')
TOTAL PARKING SPACES:	50

PROJECT	
PROPOSED SUBDIVISION	
83 ANDERSON ROAD, CHEEKTOWAGA, NEW YORK	
THE PROPOSED SITE PLAN - 83 ANDERSON ROAD	
DATE: 06.06.2011	CLIENT: KABIR GROUP, INC. 5950 MCKINLEY PARKWAY BLADELL, NEW YORK
SCALE: Noted	
DWG No: 10-060-2	
<small>COPYRIGHT © 2010. ALL RIGHTS RESERVED. NO PORTION OF THIS DRAWING AND DESIGN MAY BE REPRODUCED, STORED, OR TRANSMITTED BY ANY MEANS WITHOUT THE PRIOR WRITTEN PERMISSION FROM THE ARCHITECT. WARNING: ALTERATIONS OF THE DOCUMENT EXCEPT IN ACCORDANCE WITH THE NEW YORK STATE EDUCATION LAW, SECTION 7208, SUBSECTION 2, IS ILLEGAL. THIS IS FOR DESIGN ONLY, NOT RESPONSIBLE FOR CONSTRUCTION MEANS AND/OR METHODS.</small>	
 104 Evans Street, Lockport, New York 14094 716-438-7900 office / fax www.kabir.com From Inspiration to Installation	
Jonathan E. Bennett, Sr. ARCHITECT	
DRAWING SP-1	

1 PROPOSED SITE PLAN - 83 ANDERSON RD.
 SCALE: 1" = 20'

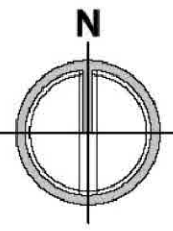

SITE LANDSCAPING PLAN

1" = 30'

LEGEND

- DENOTES AREA OF GROUND COVER PLANTING PER SPECIFICATIONS
- DENOTES AREA OF BIORETENTION (WETLAND) SEE TABLE FOR PLANTINGS

NOTES:

1. CONTRACTOR SHALL TAKE ALL REASONABLE MEASURES TO PROTECT EXISTING TREES AND PLANTINGS INDICATED TO REMAIN FROM ALL TYPES OF ROOT, TRUNK AND LIMB DAMAGE DURING DEMOLITION AND CONSTRUCTION.
2. EXISTING PLANTED AREAS SHALL BE REMOVED UNLESS OTHERWISE NOTED.
3. ALL DISTURBED AREAS SHALL RECEIVE 4" MIN. TOPSOIL AND GRASS SEED UNLESS OTHERWISE NOTED.
4. TREE AND SHRUB BEDS SHALL BE COVERED WITH 3" OF HARDWOOD MULCH. ALL ROOTS AND STONES OVER 1 1/2" SHALL BE REMOVED PRIOR TO HYDROSEEDING.
5. ALL STREET AND ISLAND TREES SHALL HAVE FIRST BRANCHING AT 6-FOOT MIN.
6. IF A CONFLICT EXISTS BETWEEN THE PLAN AND PLANTING SCHEDULE, THE PLAN SHALL GOVERN.
7. REFER TO ARCHITECTURAL DRAWINGS FOR ALL BUILDING DIMENSIONS.
8. REFER TO GRADING AND UTILITY PLAN(S) FOR ADDITIONAL INFORMATION NOT SHOWN HEREIN.

PLANTING SCHEDULE

MARK	QUANTITY	BOTANICAL NAME	COMMON NAME	SIZE	ROOT
1	3	PICEA ABIES	NORWAY SPRUCE	5'h	B&B
2	15	ACER RUBRUM (AUTUMN BLAZE)	AUTUMN BLAZE MAPLE	2 1/2" CAL	B&B
3	3	MALUS RED JADE	RED JADE CRABAPPLE	1 1/2" CAL	B&B
4	6	MALUS AMERICAN MASTERPIECE	AMERICAN MASTERPIECE CRABAPPLE	1 1/2" CAL	B&B
5	10	PINUS HELDREICHII (COMPACT GEM)	COMPACT GEM MOUNTAIN PINE	36"	B&B
6	12	JUNIPERUS SCOPULORUM	ROCKY MOUNTAIN JUNIPER	4'h	B&B
7	36	PRUNUS CISTINA	NEWPORT PLUM	24"-30"	B&B
8	6	TAXUS CUSPIDATA	WARDS YEW	24"	B&B

ANDERSON ROAD (60' WIDE)

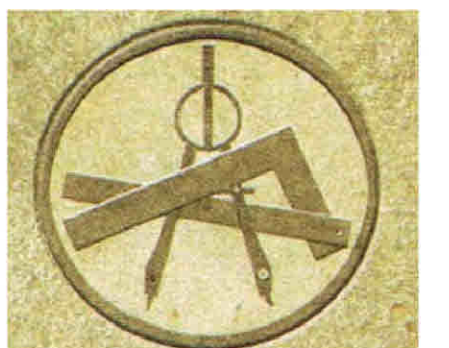
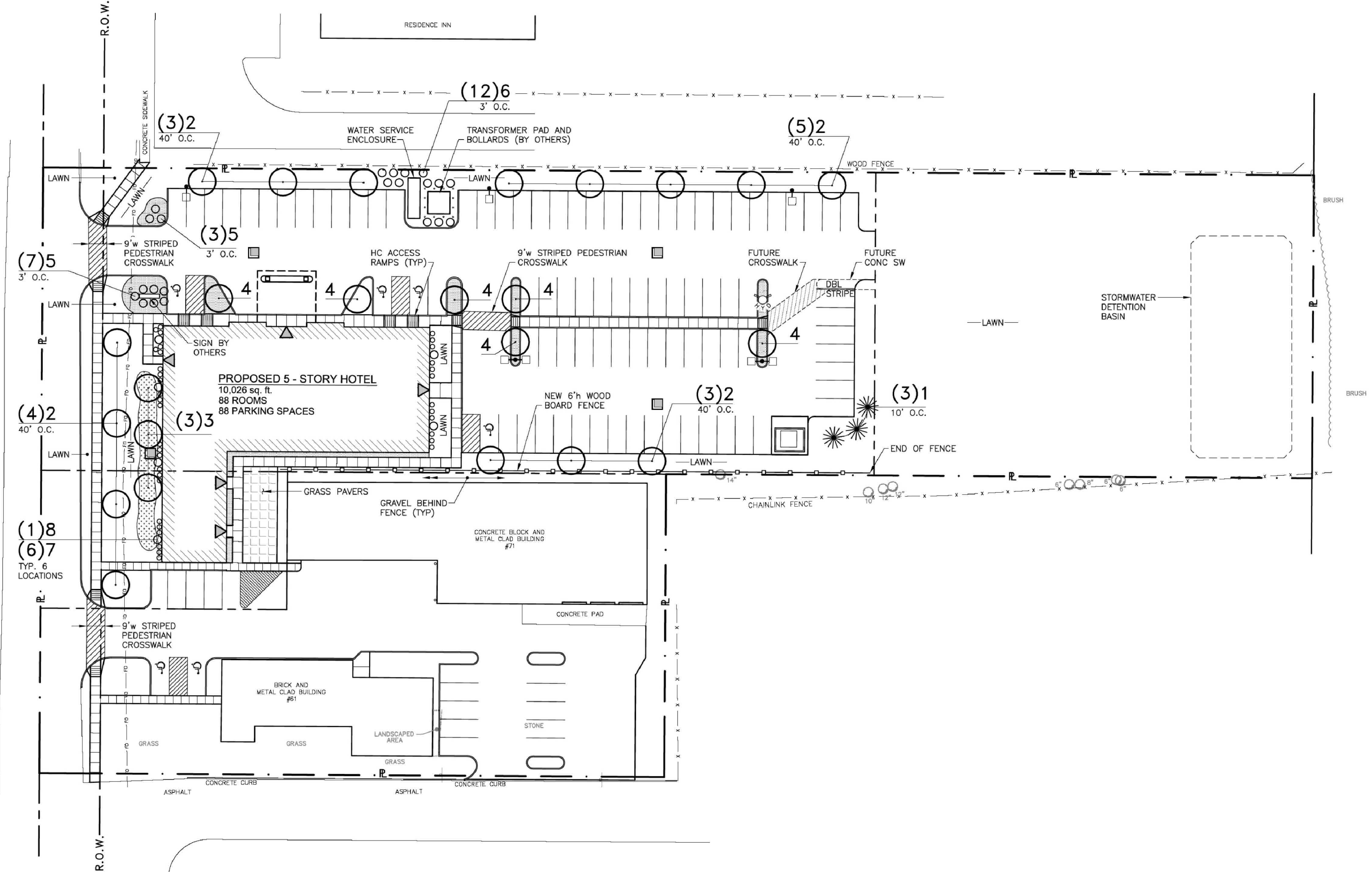

JONATHAN E. BENNETT ARCHITECTURE, P.C.
from Inspiration to Installation

104 Evans Street
Lockport, New York 14094
716-438-7940 o. 716-438-7522 f.
www.des-ae.com

CONSULTANTS

tredo ENGINEERS

85 River Rock Drive,
Suite 101
Buffalo, New York 14207
716.876.7147 ph
716.876.0667 fax

T.E. JOB No. 11.13

MARK	DATE	DESCRIPTION

PROPOSED HOTEL DEVELOPMENT

83 ANDERSON ROAD
CHEEKTOWAGA
NEW YORK 14225

KABIR GROUP, INC.
3950 MCKINLEY PARKWAY
BLASDELL, NEW YORK 14219

WARNING: ALTERATIONS OF THE DOCUMENT EXCEPT IN ACCORDANCE WITH THE NEW YORK STATE EDUCATION LAW, SECTION 7209, SUBDIVISION 2, IS ILLEGAL. THIS IS FOR DESIGN ONLY, NOT RESPONSIBLE FOR CONSTRUCTION MEANS AND/OR METHODS.

SEAL

PROJECT NO: 10-060-2
DATE: JUNE 3, 2011
DRAWN BY: MJN
CHK'D BY: AVM
COPYRIGHT © 2011

ALL RIGHTS RESERVED. NO PORTION OF THIS DRAWING AND DESIGN MAY BE REPRODUCED, STORED, OR TRANSMITTED BY ANY MEANS WITHOUT THE PRIOR WRITTEN PERMISSION FROM THE ARCHITECT.

SHEET TITLE

SITE LANDSCAPING PLAN

L-101

SHEET : 4 OF : 8

COPYRIGHT © 2011 TREDO ENGINEERS ALL RIGHTS RESERVED. NO PART OF THIS DRAWING MAY BE REPRODUCED OR COPIED IN ANY FORM BY ANY MEANS WITHOUT THE WRITTEN PERMISSION OF THE ENGINEER.
REPRODUCTION OF THIS DRAWING FOR USE IN THE PRODUCTION OF SHOP AND/OR FIELD DETAIL DRAWINGS IS EXPRESSLY FORBIDDEN.
UNAUTHORIZED ALTERATION AND/OR DUPLICATION OF THIS DRAWING IS A VIOLATION OF SECTION 7209, PROVISION 2, OF THE NEW YORK STATE EDUCATION LAW.

DOCUMENT STATUS: PROGRESS NOT FOR CONSTRUCTION RID SFT PERMIT SFT FINAL FOR CONSTRUCTION Attachment: Site Plan and Architectural Rendering (RES-2011-348 : Negative SEQR Declaration- 63161 Anderson Road)

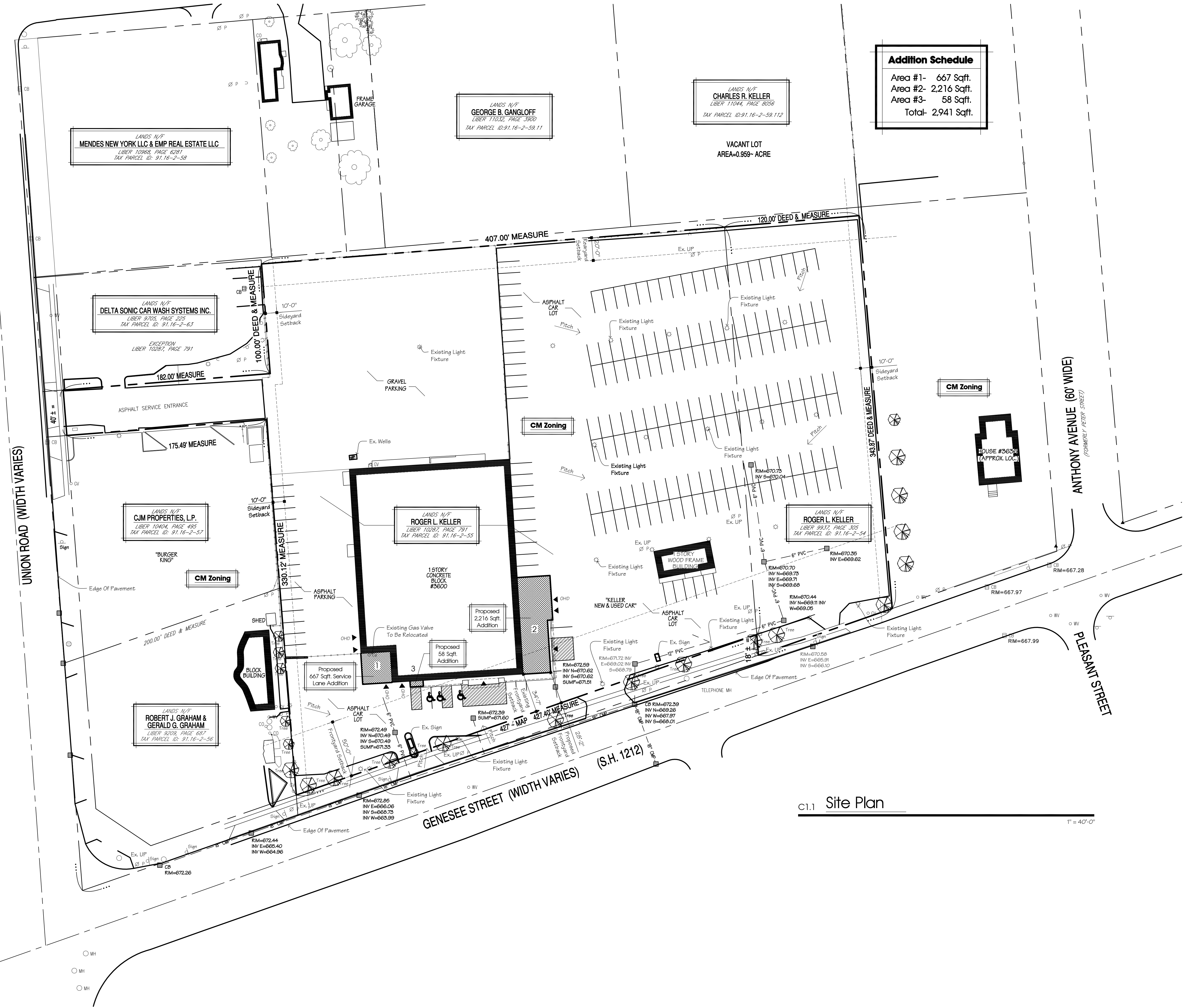

Addition Schedule	
Area #1-	667 Sqft.
Area #2-	2,216 Sqft.
Area #3-	58 Sqft.
Total-	2,941 Sqft.

c.1.1 Site Plan
 1" = 40'-0"



3284 Walden Avenue
 Depew, New York 14043
 (716) 651-0381 Fax 651-0382

Job Number:
11-146

Proposed Addition
 For:

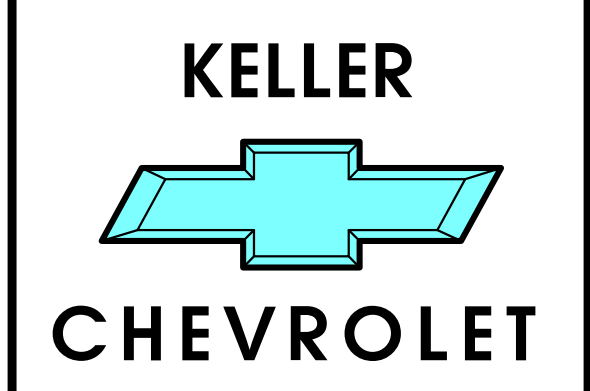

3600 Genesee St.
 Cheektowaga, NY 14225

Copyright Deansutton Architects © 2011

No.	Description	Date	By

WARNING:
 It is a violation of Article 147, Section 7303 of the New York State Education Law for any person to alter an item, in any way, on this document, unless under the direction of a licensed Architect.

Title:
Site Plan

Drawn By:
 A. Brose
 Date:
 5/29/11
 Checked:
 M. Dean
 Scale:
 1" = 40'-0"

Sheet No.:
C-1

Attachment: Keller Chevrolet - Site Plan (RES-2011-352 : Accept Site Plan - 3600 Genesee Street)

ONLINE AUCTION CONTRACT - AGREEMENT FOR SALE OF GOVERNMENT ASSETS BY ONLINE AUCTION

This Agreement made on 4/22/2010, between TOWN OF CHEEKTOWAGA, hereafter called "Seller", and Auctions International, Inc., 808 Borden Road, Cheektowaga, NY 14227, hereafter called "Auctioneer":

The Auctioneer hereby agrees to use professional skill, knowledge, and experience to the best advantage of both parties in preparing for and conducting the sale. All auction items will be sold "As-Is, Where-Is", subject to the Seller's terms.

The Seller agrees to provide Titles, Keys and all other Proof of Ownership to customers who present a paid invoice from Auctions International, and release the purchased items once the Auctioneer has received full payment for the goods listed below (and described in detail on provided condition reports, and/or provided by electronic means to Auctioneer).

GOVERNMENT VEHICLES, MACHINERY, EQUIPMENT AND ALL OTHER SURPLUS ASSETS

The Seller agrees to provide merchantable title (with no liens or encumbrances) for motor vehicles, and agrees to write-in the purchase information on the back of any titles issued to purchasers (as required by law). The Seller furthermore agrees not to sell listed merchandise before the term of the online auction is complete, under any circumstances.

The Auction is to be held online at www.AuctionsInternational.com, beginning and closing on mutually agreed dates and times. The terms and prices of this contract shall remain in effect for two (2) years after the agreement is executed, based on the needs of the Seller. Notwithstanding the foregoing, the Seller may terminate this contract at any time for convenience.

It is agreed that all listed merchandise be sold to the highest bidder, "as-is", "where-is", with no warranty expressed, implied or otherwise, and with the Government Seller retaining the right to reject any bids that are insufficient. Seller agrees to specify a minimum acceptable price on each rejected bid, which will be posted on the "Past Prices" page of the Auctioneer's website.

Purchaser(s) will be required to pay a 10% buyer premium, added to the successful high bid prices, which will constitute the Auctioneer's compensation for these services.

The Auctioneer will conduct auction(s) at no cost to the Seller, provided the Seller takes photos and descriptions of the merchandise, and provides this information to the Auctioneer's staff. The Auctioneer reserves the right to combine low-value merchandise into larger online auction lots as necessary, based on past experience with such items.

If requested by the Seller, the Auctioneer's staff will travel to the Seller's facilities to obtain photos and condition reports of the Seller's items, for the following listing fees: Thirty dollar (\$30) fee for each vehicle, and Five dollar (\$5) fee for each auction lot that is not a motor vehicle. These listing fees will be deducted from the sale proceeds, before final payment is made to Seller.

The Auctioneer will mail a check to the Seller for all proceeds collected within fifteen (15) business days after the Seller approves the bids for the sale items, along with an accounting summary and copies of receipts. In the event of a bidder's refusal or failure to pay for their invoiced items, the Auctioneer will offer the unsold merchandise to the backup bidder, and the reneging bidder will be banned from all future auctions. If the backup bidder does not take the merchandise for the backup bid price, then the merchandise will revert back to possession of the seller, after a reasonable time has been allowed for the backup bidder to get their payment to the Auctioneer. At the request of the Seller, any unsold merchandise can be re-listed in a future online auction.

INDEPENDENT STATUS. That during the existence of this agreement, the Auctioneer shall remain an individual, independent contractor, retaining its separate identity and shall in no way be considered a division, department or agent of the Seller's agency or organization.

WAIVER. No waiver of any breach of any condition of the agreement shall be binding unless in writing and signed by the party waiving said breach. No such waiver shall in any way effect any other term or condition of this agreement or constitute a cause or excuse for a repetition of such or any other breach unless the waiver shall include the same.

ENTIRE AGREEMENT. This Agreement constitutes the entire agreement among the parties with respect to the subject matter of this Agreement, and supersedes any and all prior understandings and agreements, whether written or oral, and all prior dealings of the parties with respect to the subject matter of this Agreement.

Town of Cheektowaga

(x) Mary F. Holtz
Seller's Authorizing Signature

Mary F. Holtz
Town Supervisor
Printed Name and Agency Title

686-3439 Bob Ciesielski
Telephone Number

(x) Town of Cheektowaga Central Garage, 3301 Broadway, Cheektowaga, NY 14227
Seller's Agency Payment Address (Check will be made out and mailed to Seller, from Auctioneer, for payments received)

(x) [Signature]
Auctioneer's Signature

Eric J. Abrams
Auctioneer's Printed Name
President

Attachment: Auctions International Agreement 4.22.2010 (RES-2011-357 : Authorize Auction of Surplus Veh and Equip)

AUCTION 2011 VEHICLES

#	YEAR	MAKE/MODEL	VIN	MILEAGE	DEPT.	CONDITION
1	1993	CHEV SUBN	1GNGK26K2PJ366082	66,572	POLICE 84	Frame Rot
2	1989	PETE PACKER	1XPZL50XXKD703964	295,380	SAN 33	Cab rotted packer rotted & cracked Cylinders removed
3	1989	PETE PACKER	1XPZL50X3KD703966	247,400	SAN 31	Cab rot – packer rot – parts removed
4	2001	FORD CRN VIC	2FAFP71W91X187989	102,469	POLICE 44	Ck engine light on – other engine problems
5	2005	FORD CRN VIC	2FAHP71W25X149941	119,500	POLICE 12	No Reverse
6	2006	FORD CRN VIC	2FAHP71W66X149183	160,600	POLICE 1	High mileage
7	2001	FORD TAURUS	1FAFP53U71G160845	103,200	POLICE 24	Body rot
8	2001	CHRYSLER INTREP 2	C3HH46R51H508099	95,411	POLICE 22	Engine – charging problems
9	2001	FORD TAURUS	1FAFP53UIIG160890	84,270	POOL 555	Body rot – engine problems
10	2001	CHEV VAN	1GAGG25R511215326	285,500	SENIOR 333	High mileage
11	1999	DODGE RAM 250	2B7JB21Z1XK541557	21,610	Y&R 154	Frame Rot
12	1995	FORD STAKE	1FDKF37H1SNA71455	122,000	SAN 22	Bad tranny – body rot
13	1994	FORD F 250 p/u	1FTHF26H0RLB52592	50,700	SAN 23	Frame rot
14	1990	JAC T422D	ride mower - 66132- 4005	1,869hr	FACIL 9-90	Jump start
15	1993	JAC T422D	ride mower 66132-5469	1,882hr	FACIL 1-93	Jump start
16	1994	FORD F 250 p/u	2FTHF26H2RCA46400	67,900	POOL 508	Body rot
17	UNK	FISHER PRO CAST	salter - 04061230000594706-1 -		FACILITY	Motor Seized
18	UNK	HOBART BETA MIG 200	MODEL # RC1-200 -		CENT GARAGE	Works Intermittently
19	1994	OLDS CIERA	1G3AG55N1R6324030	91,400	POLICE 67	Salvage Only No Title
20	2001	GESTETNER	3235E H52 16200571		CENT GAR	From Courts -Too Costly to Repair

Attachment: Auction 2011 - Vehicles and Equipment (RES-2011-357 : Authorize Auction of Surplus Veh and Equip)



Town of Cheektowaga

Regular Meeting

~ Minutes ~

3301 Broadway
Cheektowaga, NY 14227
<http://www.town.cheektowaga.ny.us>

Alice Magierski
716-686-3400

Tuesday, July 5, 2011

6:45 PM

Council Chambers

I. Call to Order

6:45 PM Meeting called to order on July 5, 2011 at Council Chambers, 3301 Broadway St, Cheektowaga, NY.

Attendee Name	Organization	Title	Status	Arrived
Mary Holtz	Town of Cheektowaga	Supervisor	Present	
Patricia Jaworowicz	Town of Cheektowaga	Councilmember	Present	
Jeff Swiatek	Town of Cheektowaga	Councilmember	Present	
James Rogowski	Town of Cheektowaga	Councilmember	Present	
Richard Zydel	Town of Cheektowaga	Councilmember	Present	
Charles Markel	Town of Cheektowaga	Councilmember	Present	
Stanley Kaznowski	Town of Cheektowaga	Councilmember	Present	

2. Additional Attendees

Thomas Adamczak, Supervising Building and Plumbing Inspector
Brian Krause, Director of Finance and Administration
John Marriott, Planning Board Chairman
William Pugh, Town Engineer
Anthony Romano, Coordinator of Employee Relations
Kevin Schenk, Town Attorney
Captain James Speyer, Police Department

II. Public Comment Period

III. Public Hearing

1. Rezoning of 4989 Genesee St. from CM General Commercial and R-Residence to RA - Apartment District

This being the time and place advertised for a Public Hearing, the Supervisor directed the Town Clerk to present that such notice has been duly published and posted; upon the order of the Supervisor such proof was duly filed.

The Supervisor announced that the Town Board would hear all persons interested in the subject of the hearing. Comments were heard, after which the Supervisor declared the hearing closed, decision was reserved.

RESULT: CLOSED [UNANIMOUS]
MOVER: James Rogowski, Councilmember
SECONDER: Charles Markel, Councilmember

AYES: Holtz, Jaworowicz, Swiatek, Rogowski, Zydel, Markel, Kaznowski

IV. Resolutions



1. RESOLUTION 2011-374

Warrant

Sponsored By: Supervisor Holtz, Councilmember Swiatek

BE IT RESOLVED, that the following Vouchers & Warrants submitted to the Town of Cheektowaga prior to July 1, 2011 are hereby approved and made a part hereof;

GENERAL FUND	\$ 3,385,318.56
RISK RETENTION FUND	109,550.74
DEBT SERVICE FUND	1,375,984.50
HUD HOUSING REHABILITATION FUND	5,724.00
SPECIAL DISTRICTS FUND	1,181,637.32
HIGHWAY FUND	681,019.31
CAPITAL FUND	850,338.83
TRUST & AGENCY FUND	51,116.25
HUD CDBG FUND	2,629.97
PART TOWN FUND	175,562.29
NYS AFFORDABLE HOUSING	950.00
	<u>\$ 7,819,831.77</u>

RESULT: **ADOPTED [UNANIMOUS]**

MOVER: Mary Holtz, Supervisor

SECONDER: Jeff Swiatek, Councilmember

AYES: Holtz, Jaworowicz, Swiatek, Rogowski, Zydel, Markel, Kaznowski



2. RESOLUTION 2011-375

Amend Agreement with Trautman Associates for Addition and Renovations to the Police and Court Building Project

Sponsored By: Supervisor Holtz, Councilmember Rogowski

WHEREAS, by resolution dated September 7, 2010, the firm of Trautman Associates, Project Architect, was retained to provide Professional Services during construction for the Addition and Renovations to the Police and Court Building Project, AND

WHEREAS, following project commencement, various enhancements have been incorporated into said project, including, but not limited to Dispatch Office systems, furniture, fixture and equipment (FF/E), Firing Range equipment, relocation of the domestic water service and related improvements, AND

WHEREAS, these project enhancements and modifications recommended by Police/Court administration staff and Engineering Department project management personnel have required the preparation of revised drawings, specifications and coordination responsibilities for electrical, communication systems, and HVAC system modifications beyond the original project scope as described in a letter from Trautman Associates dated June 13, 2011, NOW, THEREFORE, BE IT

RESOLVED, that the agreement with the firm of Trautman Associates, 470 Franklin Street, Buffalo, New York 14202 be amended to include the aforesaid additional design services for the additional sum of \$30,980.00, AND, BE IT FURTHER

RESOLVED, that funding for said professional services shall be chargeable to Account #500-1910-9399-5025.

RESULT:	ADOPTED [UNANIMOUS]
MOVER:	Mary Holtz, Supervisor
SECONDER:	James Rogowski, Councilmember
AYES:	Holtz, Jaworowicz, Swiatek, Rogowski, Zydel, Markel, Kaznowski



3. RESOLUTION 2011-376

Change Order No. 1 (Plumbing Work) Police & Court Building

Sponsored By: Supervisor Holtz, Councilmember Rogowski

WHEREAS, the contract for Plumbing Work for the Police & Court Building Addition and Renovations Project was awarded by Town Board Resolution dated September 7, 2010 to MKS Plumbing Corporation, 19 Ransier Drive, West Seneca, New York 14224 in the amount of \$990,000.00, AND

WHEREAS, the Project Architect, Trautman Associates, and the Town Engineer have recommended the approval of Change Order No. 1 (Plumbing Work) which provides for modifications to roof drainage piping and revisions to the domestic water service as further detailed in the change order document, NOW, THEREFORE, BE IT

RESOLVED, that Change Order No. 1 (Plumbing Work) for the Police & Court Building Addition and Renovations Project in the amount of \$1,336.93 as an addition to the contract for plumbing work, to be offset by the contract contingency allowance, be and hereby is approved, AND, BE IT FURTHER

RESOLVED, that the Supervisor is hereby authorized and directed to execute said Change Order No. 1 document on behalf of this Town Board.

RESULT:	ADOPTED [UNANIMOUS]
MOVER:	Mary Holtz, Supervisor
SECONDER:	James Rogowski, Councilmember
AYES:	Holtz, Jaworowicz, Swiatek, Rogowski, Zydel, Markel, Kaznowski



4. RESOLUTION 2011-377

Change Order No. 2 (HVAC Work) Addition and Renovations to the Police & Court Building Project

Sponsored By: Supervisor Holtz, Councilmember Rogowski

WHEREAS, the contract for HVAC Work for the Police & Court Building Addition and Renovations Project was awarded by Town Board Resolution dated September 7, 2010 to MLP Plumbing and Mechanical, Inc., 3198 Union Road, Suite 300, Cheektowaga, New York 14227 in the amount of \$1,818,000.00, AND

WHEREAS, the Project Architect, Trautman Associates, and the Town Engineer have recommended the approval of Change Order No. 2 (HVAC Work) which provides for split system air conditioning required for the recently enhanced dispatch room as further detailed in the change order document, NOW, THEREFORE, BE IT

RESOLVED, that Change Order No. 2 (HVAC Work) for the Police & Court Building Addition and Renovations Project in the amount of \$50,341.00 as an addition to the contract for HVAC, of which \$39,500.00 will be offset by the contract contingency allowance, be and hereby is approved, AND, BE IT FURTHER

RESOLVED, that the Supervisor is hereby authorized and directed to execute said Change Order No. 2 document on behalf of this Town Board, AND, BE IT FURTHER

RESOLVED, that the balance of \$16,831.00 beyond the contingency amount be chargeable to Account #500-1440-2528-5025.

RESULT:	ADOPTED [UNANIMOUS]
MOVER:	Mary Holtz, Supervisor
SECONDER:	James Rogowski, Councilmember
AYES:	Holtz, Jaworowicz, Swiatek, Rogowski, Zydel, Markel, Kaznowski



5. RESOLUTION 2011-378

Change Order No. 1 (Electrical Work) Addition and Renovations to the Police & Court Building Project

Sponsored By: Supervisor Holtz, Councilmember Rogowski

WHEREAS, the contract for Electrical Work for the Police and Court Building Addition and Renovations Project was awarded by Town Board Resolution dated September 7, 2010 to Industrial Power & Lighting Corporation, 701 Seneca Street, Buffalo, New York 14210 in the amount of \$1,889,000.00, AND

WHEREAS, the Project Architect, Trautman Associates and the Town Engineer have recommended the approval of Change Order #1 (Electrical Work) which provides for various enhancements, including electrical and data revisions for newly purchased office and dispatch furniture systems, the replacement of a main distribution panel and revisions made to a new target and trap system in the shooting range as further detailed in the change order document, NOW, THEREFORE, BE IT

RESOLVED, that Change Order No. 1 (Electrical Work) for the Police and Court Building Addition and Renovations Project in the amount of \$111,052.26 as an addition to the contract for Electrical Work, of which \$59,500.00 will be offset by the contract contingency allowance, be and hereby is approved, AND, BE IT FURTHER

RESOLVED, that the Supervisor is hereby authorized and directed to execute said Change Order No. 1 document on behalf of this Town Board, AND, BE IT FURTHER

RESOLVED, that the balance of \$51,552.26 beyond the contingency amount be chargeable to Account #500-1440-2528-5025.

RESULT:	ADOPTED [UNANIMOUS]
MOVER:	Mary Holtz, Supervisor
SECONDER:	James Rogowski, Councilmember
AYES:	Holtz, Jaworowicz, Swiatek, Rogowski, Zydel, Markel, Kaznowski



6. RESOLUTION 2011-379

Change Order No. 3 (General Construction Work) Addition and Renovations to the Police & Court Building Project

Sponsored By: Supervisor Holtz, Councilmember Rogowski

WHEREAS, the contract for General Construction Work for the Police and Court Building Addition and Renovations Project was awarded by Town Board Resolution dated September 7, 2010 to Burgio & Campofelice, Inc., 2570 Walden Avenue, Cheektowaga, New York 14225 in the amount of \$9,033,643.00, AND

WHEREAS, the Project Architect, Trautman Associates, and the Town Engineer have recommended the approval of Change Order No. 3 (General Construction Work) which provides for modifications to the domestic water service, construction of a fire sprinkler maintenance closet and for the replacement of unsuitable soils encountered during parking lot construction with select granular material as further detailed in the change order document, NOW, THEREFORE, BE IT

RESOLVED, that Change Order No. 3 (General Construction Work) for the Police & Court Building Addition and Renovations Project, as an addition to the contract for General Construction Work in the amount of \$19,884.00 to be offset by the contract contingency allowance, be and hereby is approved, AND, BE IT FURTHER

RESOLVED, that the Supervisor is hereby authorized and directed to execute said Change Order No. 3 document on behalf of this Town Board.

RESULT:	ADOPTED [UNANIMOUS]
MOVER:	Mary Holtz, Supervisor
SECONDER:	James Rogowski, Councilmember
AYES:	Holtz, Jaworowicz, Swiatek, Rogowski, Zydel, Markel, Kaznowski



7. RESOLUTION 2011-380

Accept Site Plan - 1 Walden Galleria Drive- Gordon Biersch

Sponsored By: Councilmember Markel, Councilmember Rogowski

WHEREAS, pursuant to the Zoning Law of the Town of Cheektowaga, the Planning Board reviews various development review applications for site plans, rezonings, special permits and realty subdivisions and renders its recommendation concerning the compatibility of such application with the zoning regulations, Town Master Plan and neighborhood character, AND

WHEREAS, the Town Board, pursuant to the Zoning Law of the Town of Cheektowaga, is required to affirm, modify or reject any recommendation submitted to it by the Planning Board, AND

WHEREAS, a development review application and site plan was submitted by John A. Ecklund of Pyramid Corp. for the construction of an exterior dining area for a proposed restaurant (Gordon Biersch) at 1 Galleria Drive, AND

WHEREAS, the Town of Cheektowaga Planning Board at its meeting of June 9, 2011 is recommending the approval of the site plan, AND

WHEREAS, this Town Board has reviewed the development review application and recommendations made by the Planning Board, NOW THEREFORE, BE IT

RESOLVED, that this Town Board determines that the project site plan is acceptable.

RESULT:	ADOPTED [UNANIMOUS]
MOVER:	Charles Markel, Councilmember
SECONDER:	James Rogowski, Councilmember
AYES:	Holtz, Jaworowicz, Swiatek, Rogowski, Zydel, Markel, Kaznowski



8. RESOLUTION 2011-381

Accept Site Plan - 4217 Genesee Street

Sponsored By: Councilmember Markel, Councilmember Rogowski

WHEREAS, pursuant to the Zoning Law of the Town of Cheektowaga, the Planning Board reviews various development review applications for site plans, rezonings, special permits and realty subdivisions and renders its recommendation concerning the compatibility of such application with the zoning regulations, Town Master Plan and neighborhood character, AND

WHEREAS, the Town Board, pursuant to the Zoning Law of the Town of Cheektowaga, is required to affirm, modify or reject any recommendation submitted to it by the Planning Board, AND

WHEREAS, a development review application and site plan was submitted by Jonathan E. Bennett Architecture, P.C. for the construction of an accessory parking area at an existing hotel (Quality Inn) at 4217 Genesee Street, AND

WHEREAS, the Town of Cheektowaga Planning Board at its meeting of June 9, 2011 is recommending the approval of the site plan, AND

WHEREAS, the subject parking area requires an area variance for the setback to the Burgess Boulevard road right of way, AND

WHEREAS, this Town Board has reviewed the development review application and recommendations made by the Planning Board, NOW THEREFORE, BE IT

RESOLVED, that this Town Board determines that the project site plan is acceptable subject to :

1. The Town Engineer reviewing and approving the grading/drainage plan.
2. The Cheektowaga Zoning Board of Appeals granting the necessary area variance.

RESULT:	ADOPTED [UNANIMOUS]
MOVER:	Charles Markel, Councilmember
SECONDER:	James Rogowski, Councilmember
AYES:	Holtz, Jaworowicz, Swiatek, Rogowski, Zydel, Markel, Kaznowski



9. RESOLUTION 2011-382

Accept Site Plan - 4795 & 4825 Genesee Street

Sponsored By: Councilmember Markel, Councilmember Rogowski

WHEREAS, pursuant to the Zoning Law of the Town of Cheektowaga, the Planning Board reviews various development review applications for site plans, rezonings, special permits and realty subdivisions and renders its recommendation concerning the compatibility of such application with the zoning regulations, Town Master Plan and neighborhood character, AND

WHEREAS, the Town Board, pursuant to the Zoning Law of the Town of Cheektowaga, is required to affirm, modify or reject any recommendation submitted to it by the Planning Board, AND

WHEREAS, a development review application and site plan was submitted by Bella Vista Group on behalf of the landowner Samuel Tadio Trust for the construction of a 15,500 square foot veterinary clinic at 4795 & 4825 Genesee Street, AND

WHEREAS, on November 2, 2009 the this Board previously issued a Negative SEQR Declaration and approved the site plan for the subject project, AND

WHEREAS, on November 3, 2010 the subject site plan expired pursuant to section 260-53B of the Town Zoning Law, as a consequence of the developers failure to file a building permit within one year of the original site plan approval, AND

WHEREAS, the Town of Cheektowaga Planning Board at its meeting of June 9, 2011 is recommending the re-approval of the site plan, AND

WHEREAS, this Town Board has reviewed the development review application and recommendations made by the Planning Board, NOW THEREFORE, BE IT

RESOLVED, that this Town Board determines that the project site plan is acceptable and re-affirms the Negative SEQR Declaration previously issued on November 2, 2009.

RESULT:	ADOPTED [UNANIMOUS]
MOVER:	Charles Markel, Councilmember
SECONDER:	James Rogowski, Councilmember
AYES:	Holtz, Jaworowicz, Swiatek, Rogowski, Zydel, Markel, Kaznowski



10. RESOLUTION 2011-383

Adopt Credit Card Policy

Sponsored By: Supervisor Holtz, Councilmember Swiatek

WHEREAS, various department heads throughout the Town utilize a Town credit card to make purchases in a cost effective manner when they determine it to be appropriate, therefore, be it,

RESOLVED, that this Town Board hereby adopts the attached Credit Card Policy of the Town of Cheektowaga, effective immediately.

Attachments:

Credit Card Policy 6.28.2011 (PDF)

RESULT: ADOPTED [UNANIMOUS]

MOVER: Mary Holtz, Supervisor

SECONDER: Jeff Swiatek, Councilmember

AYES: Holtz, Jaworowicz, Swiatek, Rogowski, Zydel, Markel, Kaznowski



11. RESOLUTION 2011-384

Authorize Execution of JAG Grant Application for Police Department

Sponsored By: Councilmember Jaworowicz, Councilmember Rogowski

WHEREAS, grant monies are available to select municipalities through the Bureau of Justice Assistance, Edward R. Byrne Justice Assistance Grant; and

WHEREAS, three communities in Erie Country, including Erie County, the City of Buffalo, and the Town of Cheektowaga are eligible to receive monies through submission of a joint application; and

WHEREAS, the grant application must be in consortium with the other eligible applicants and, the City of Buffalo has agreed to serve as the lead agency for the purpose of securing and administering these grant funds; and

WHEREAS, the Town of Cheektowaga Police Department is eligible to receive \$22,649 in funding through the program, NOW, THEREFORE, BE IT

RESOLVED, that Grantmakers Advantage, Inc. the Town's grants consultant, be and hereby is authorized and directed to complete the necessary application, forms, etc. to be submitted for the purpose of securing this grant, and BE IT FURTHER

RESOLVED, that the Supervisor and Police Chief be and hereby are authorized and directed to execute any and all documents pertaining to the application for and acquisition of said funding.

RESULT:	ADOPTED [UNANIMOUS]
MOVER:	Patricia Jaworowicz, Councilmember
SECONDER:	James Rogowski, Councilmember
AYES:	Holtz, Jaworowicz, Swiatek, Rogowski, Zydel, Markel, Kaznowski



12. RESOLUTION 2011-385

Renew Flood Insurance Coverage for Anna Reinstein Library

Sponsored By: Supervisor Holtz, Councilmember Swiatek

WHEREAS, the Town's Flood Insurance Coverage for the Anna Reinstein Library at 2580 Harlem Road will be expiring on July 19, 2011, and

WHEREAS, Holfoth Risk Management, the Town's insurance consultant, solicited a renewal quote from Travelers Insurance Company (guaranteed through the Federal Flood Program) for this flood insurance coverage, and has recommended that we renew said insurance through Travelers Insurance Company, NOW, THEREFORE, BE IT

RESOLVED, that this Town Board hereby awards the flood insurance for the Anna Reinstein Library with coverage to Travelers Insurance Company in the amount of \$27,200.00 for an annual premium of \$2,044.00, and BE IT FURTHER

RESOLVED, that moneys for said insurance shall be appropriated from budget line item number 101.1710.4101.

RESOLVED, that the Supervisor be and hereby is authorized and directed to execute any and all documents to effectuate this flood insurance coverage.

RESULT:	ADOPTED [UNANIMOUS]
MOVER:	Mary Holtz, Supervisor
SECONDER:	Jeff Swiatek, Councilmember
AYES:	Holtz, Jaworowicz, Swiatek, Rogowski, Zydel, Markel, Kaznowski



13. RESOLUTION 2011-386

Minor Demolition Patio Roof/96 East Toulon Dr

Sponsored By: Councilmember Markel, Councilmember Kaznowski

WHEREAS, Town of Cheektowaga Law for the Administration and Enforcement of the Codes of New York State; and the Property Maintenance Code of New York State require that all vacant structures and premises shall be maintained in clean, safe, secure and sanitary conditions so as not to cause a blighting problem or adversely affect the public health or safety and all nuisances abated, AND

WHEREAS, the Town of Cheektowaga has received notification of an unsafe structure and premises located at 96 East Toulon Drive, Cheektowaga, New York SBL# 125.06-5-24 that is a danger to the safety of others, and records kept by the Assessors Office identify Paul R. Diviak, Paul J. Diviak Atty., 649 Harlem Road, West Seneca, New York 14224, as the owner AND

WHEREAS, an inspection of such premises was conducted at 96 East Toulon Drive, by the Housing and Neighborhood Preservation Office, AND

WHEREAS, such inspection found the premises to be deteriorated, vacant, a hazard, and a danger to the safety and well being of others, AND

WHEREAS, the Town of Cheektowaga Housing and Neighborhood Preservation Office properly notified the property owner in accordance with the Town of Cheektowaga Law for the Administration and Enforcement of the Codes of New York State, and the owner failed to take actions to safeguard the premises, AND

WHEREAS, these conditions require the Town of Cheektowaga Housing and Neighborhood Preservation Office to take immediate steps to safeguard the premises to protect the health and safety of others and abate all nuisances, NOW, THEREFORE BE IT

RESOLVED, that pursuant to Section 70-7A.(5) and Section 70-8 of the Town of Cheektowaga Law for the Administration and Enforcement of the Codes of New York State that the vacant structure premises be safeguarded and all nuisances abated; and all costs incurred be assessed against the property hereinbefore described

RESULT:	ADOPTED [UNANIMOUS]
MOVER:	Charles Markel, Councilmember
SECONDER:	Stanley Kaznowski, Councilmember
AYES:	Holtz, Jaworowicz, Swiatek, Rogowski, Zydel, Markel, Kaznowski



14. RESOLUTION 2011-387

Demolition of Accessory Structure/71 Southgate Rd

Sponsored By: Councilmember Markel, Councilmember Kaznowski

WHEREAS, Town of Cheektowaga Law for the Administration and Enforcement of the Codes of New York State; and the Property Maintenance Code of New York State require that all vacant structures and premises shall be maintained in clean, safe, secure and sanitary conditions so as not to cause a blighting problem or adversely affect the public health or safety and all nuisances abated, AND

WHEREAS, the Town of Cheektowaga has received notification of an unsafe structure and premises located at 71 Southgate Road,, Cheektowaga, New York SBL# 90.08-7-14 that is a danger to the safety of others, and records kept by the Assessors Office identify David P. Stewart, 71 Southgate Road, Cheektowaga, New York 14215, as the owner AND

WHEREAS, an inspection of such premises was conducted at 71 Southgate Road, by the Housing and Neighborhood Preservation Office, AND

WHEREAS, such inspection found the premises to be deteriorated, vacant, a hazard, and a danger to the safety and well being of others, AND

WHEREAS, the Town of Cheektowaga Housing and Neighborhood Preservation Office properly notified the property owner in accordance with the Town of Cheektowaga Law for the Administration and Enforcement of the Codes of New York State, and the owner failed to take actions to safeguard the premises, AND

WHEREAS, these conditions require the Town of Cheektowaga Housing and Neighborhood Preservation Office to take immediate steps to safeguard the premises to protect the health and safety of others and abate all nuisances, NOW, THEREFORE BE IT

RESOLVED, that pursuant to Section 70-7A.(5) and Section 70-8 of the Town of Cheektowaga Law for the Administration and Enforcement of the Codes of New York State that the vacant structure premises be safeguarded and all nuisances abated; and all costs incurred be assessed against the property hereinbefore described

RESULT:	ADOPTED [UNANIMOUS]
MOVER:	Charles Markel, Councilmember
SECONDER:	Stanley Kaznowski, Councilmember
AYES:	Holtz, Jaworowicz, Swiatek, Rogowski, Zydel, Markel, Kaznowski



15. RESOLUTION 2011-388

Authorization for Purchase - Two (2) License Plate Readers

Sponsored By: Councilmember Jaworowicz, Councilmember Rogowski

WHEREAS, the Cheektowaga Town Board and Cheektowaga Police Department, in the wake of the recent homicide in Cheektowaga Town Park, have pledged to do all that is possible to make its neighborhoods and parks safer for its residents and visitors, AND

WHEREAS, the Cheektowaga Police Department has added manpower to local events in the community to promote safety and well-being for those attending activities, AND

WHEREAS, in an effort to monitor usage in and out of Cheektowaga Town Park wish to purchase two (2) fixed mount license plate readers, AND

WHEREAS, to be compatible with the system the Erie County Central Police Services Department utilizes, which would retrieve license plate data for the Cheektowaga Police Department, AND

WHEREAS, the County of Erie has agreed to cover the cost of the two (2) air cards needed for the License Plate Readers, AND

WHEREAS, ELSAG North America, 205 - H Creek Ridge Road, Greensboro, North Carolina 27406 offers the FPH-900 35 CAM & MT License Plate Readers that is compatible with Erie County Central Police Services and is acceptable by the County of Erie, AND

WHEREAS, ELSAG offers the License Plate Readers under New York State Contract #PC62119, AND

WHEREAS, money has been appropriated for this purchase out of Budget Line #0600-0881, NOW, THEREFORE, BE IT

RESOLVED, that the Town Board hereby authorizes the purchase of two (2) License Plate Readers (FPH-900 35 CAM & MT), installation and EOC Licensing Fees for the total cost of \$36,636.00 from:

ELSAG North America
205 - H Creek Ridge Road
Greensboro, North Carolina 27406

RESULT:	ADOPTED [UNANIMOUS]
MOVER:	Patricia Jaworowicz, Councilmember
SECONDER:	James Rogowski, Councilmember
AYES:	Holtz, Jaworowicz, Swiatek, Rogowski, Zydel, Markel, Kaznowski



16. RESOLUTION 2011-389

Authorization for Purchase of Police Fingerprint System

Sponsored By: Councilmember Jaworowicz, Councilmember Rogowski

WHEREAS, the County of Erie, which oversees 29 municipal police agencies including the Cheektowaga Police Department, is the repository for fingerprints and mugshots for these agencies, AND

WHEREAS, the County of Erie is requiring these agencies to use the identical fingerprint system to be compatible with their system, AND

WHEREAS, the County of Erie uses the Touchprint TM 5100 Digital Fingerprint Scanning System, AND

WHEREAS, Comnetix, Inc., 2872 Bristol Circle, Suite 100, Oakville, Ontario, Canada, offers this system under New York State Contract # PT63109, AND

WHEREAS, said cost of the Touchprint fingerprint system is \$14,663.00 and the maintenance contract through June 13, 2013 is \$2,053.00 for a grand total of \$16,716.00, AND

WHEREAS, money has been budgeted for said purchase from budget line #0600-0881, NOW, THEREFORE, BE IT

RESOLVED, that the Town Board hereby authorizes the purchase of the Touchprint TM 5100 Digital Fingerprint Scanning System and maintenance contract from:

Comnetix, Inc.
2872 Bristol Circle, Suite 100
Oakville, Ontario L6H 6G4
CANADA

RESULT:	ADOPTED [UNANIMOUS]
MOVER:	Patricia Jaworowicz, Councilmember
SECONDER:	James Rogowski, Councilmember
AYES:	Holtz, Jaworowicz, Swiatek, Rogowski, Zydel, Markel, Kaznowski



17. RESOLUTION 2011-390

Special Event - HSBC - Softball Tournament

Sponsored By: Councilmember Rogowski, Councilmember Zydel

WHEREAS, by resolution dated May 1, 1995, this Town Board adopted a Special Events policy, which requires anyone wishing to hold a special event in the Town to file an application and supporting documentation, fees, etc. to the Town Clerk prior to the special event, and

WHEREAS, the HSBC Sports Club has made application to hold its Softball Tournament in Stiglmeier Park on Saturday, August 13, 2011 from 8:00 a.m. to 6:00 p.m., and

WHEREAS, this Board has reviewed the aforementioned application, which application has been approved by the Police Department, Facilities Department and the Department of Youth & Recreational Services, and has no objection to same, and

WHEREAS, due to the nature of the event, this Town Board hereby waives the following requirements:

1. Submittal of plan for sanitary facilities;
2. Submittal of site plan;
3. Submittal of Security Plan;
4. Submittal of Fire Prevention/Emergency Services Plan;

NOW, THEREFORE, BE IT

RESOLVED, that this Town Board hereby approves the aforementioned application of the HSBC Sports Club for the aforementioned Softball Tournament to be held in Stiglmeier Park on Saturday, August 13, 2011.

RESULT:	ADOPTED [UNANIMOUS]
MOVER:	James Rogowski, Councilmember
SECONDER:	Richard Zydel, Councilmember
AYES:	Holtz, Jaworowicz, Swiatek, Rogowski, Zydel, Markel, Kaznowski



18. RESOLUTION 2011-391

Special Event - Pulaski Day Parade

Sponsored By: Supervisor Holtz, Councilmember Rogowski

WHEREAS, the General Pulaski Association has made application to hold a parade honoring General Pulaski on Sunday, July 17, 2011 at 1:30 p.m. beginning at the Thruway Plaza; then proceeding west on Walden Avenue; then north on Harlem Road to George Urban Boulevard, and

WHEREAS, this Board has reviewed the aforementioned application, which application has been approved by the Police Department, Highway Department and Facilities Department and has no objection to same, and

WHEREAS, due to the nature of the event, this Town Board hereby waives the following requirements:

1. Submittal of plan for sanitary facilities;
2. Submittal of site plan;
3. Submittal of Security Plan;
4. Submittal of Fire Prevention/Emergency Services Plan;

NOW, THEREFORE, BE IT

RESOLVED, that this Town Board hereby approves the aforementioned application of the General Pulaski Association for the aforementioned parade to be held on July 17, 2011, and BE IT FURTHER

RESOLVED, that the Chief of Police be and hereby is directed to provide traffic safety and escort services for such parade and to ensure compliance with Section 1660(a)(6) of the Vehicle and Traffic Law.

RESULT:	ADOPTED [UNANIMOUS]
MOVER:	Mary Holtz, Supervisor
SECONDER:	James Rogowski, Councilmember
AYES:	Holtz, Jaworowicz, Swiatek, Rogowski, Zydel, Markel, Kaznowski



19. RESOLUTION 2011-392

Retention of Outside Counsel for Assessment Matters

Sponsored By: Councilmember Jaworowicz, Supervisor Holtz

WHEREAS, each year, various Real Property Tax Law Article 7 proceedings are commenced against the Town of Cheektowaga and the Town of Cheektowaga Assessor, and

WHEREAS, the Town of Cheektowaga presently retains one firm to represent the Town with respect to these proceedings, and

WHEREAS, due to the potential volume of cases (additional proceedings are expected to be commenced this year), there is a need to retain additional legal counsel to represent the Town's interests in certain of these proceedings in order to protect the integrity of the Town's assessment base, and

WHEREAS, moneys have been budgeted by the Town for this purpose, and

WHEREAS, the Town Attorney's Office has received proposals from outside counsel to handle these matters, NOW, THEREFORE, BE IT

RESOLVED, that Bennett, DiFilippo & Kurtzhalts, LLP (Joel Kurtzhalts, Of Counsel), Attorneys at Law, be and hereby is retained as outside counsel to represent the Town of Cheektowaga and the Town Assessor in Article 7 proceedings, pursuant to direction from the Town Attorney, as per the proposal submitted by said outside counsel, and BE IT FURTHER

RESOLVED, that payments for said outside counsel shall be appropriated from budget line item number 100-1355-4561.

RESULT:	ADOPTED [UNANIMOUS]
MOVER:	Patricia Jaworowicz, Councilmember
SECONDER:	Mary Holtz, Supervisor
AYES:	Holtz, Jaworowicz, Swiatek, Rogowski, Zydel, Markel, Kaznowski



20. RESOLUTION 2011-393

Youth & Recreation Termination

Sponsored By: Councilmember Zydel, Councilmember Rogowski

BE IT RESOLVED that the individuals listed below be and hereby are terminated in the Department of Youth & Recreational Services, effective as indicated:

Mary Wroblewski	Never worked	14227
-----------------	--------------	-------

Motion by Councilmember Rogowski; Seconded by Supervisor Holtz to waive the reading of names for the following three (3) resolutions: 2011-393; 2011-394 and 2011-395. Motion Carried.

RESULT:	ADOPTED [UNANIMOUS]
MOVER:	Richard Zydel, Councilmember
SECONDER:	James Rogowski, Councilmember
AYES:	Holtz, Jaworowicz, Swiatek, Rogowski, Zydel, Markel, Kaznowski



21. RESOLUTION 2011-394

Youth & Recreation Hiring/Transfers

Sponsored By: Councilmember Zydel, Councilmember Rogowski

BE IT RESOLVED that the individuals listed below be and hereby are hired and/or transferred, as indicated, in the Department of Youth & Recreational Services, effective immediately:

Laborer "Bathhouse Attendant" - 7180.1901 - \$7.25 - Seasonal

Tyler Kunkel	14225
Tyler Nosal	14225

Recreation Attendant - 7310.1802 - \$8.00 - Seasonal

Amy Wroblewski	14225
----------------	-------

Lifeguard - Level I - 7180.1903 - \$8.25 - Seasonal

Rose Rustowicz	14225
Trevor Sacilowski	142255

Recreation Attendant - 7140.1645 - \$7.35 - Regular Part-time

Richard Burton Jr.	14225
Brian Grabiec	14225

From Regular Part-time to Part-time - Lifeguard - 7180.1903 - \$8.42

Keileigh Pecyne

BE IT FURTHER RESOLVED, the following employee information be amended as follows:

Recreation Attendant
From Mauren Szydowski to Lauren Szydowski

Recreation Attendant
From Evan Bernard to Evin Bernard

Recreation Aide
Daniel Urshel from appointment date of 6/20/11 to 6/7/11

RESULT:	ADOPTED [UNANIMOUS]
MOVER:	Richard Zydel, Councilmember
SECONDER:	James Rogowski, Councilmember
AYES:	Holtz, Jaworowicz, Swiatek, Rogowski, Zydel, Markel, Kaznowski



22. RESOLUTION 2011-395

Hiring/Termination of Part-Time/Seasonal Employees

Sponsored By: Councilmember Swiatek, Supervisor Holtz

BE IT RESOLVED, that the following individuals be and hereby are hired as **SEASONAL EMPLOYEES**, not to exceed five (5) months in a calendar year, in the various departments listed and in compliance with Civil Service Laws and Regulations as well as the provisions of the Town's collective bargaining agreement between the Town of Cheektowaga and the Town of Cheektowaga Employees Association:

SANITATION DEPARTMENT Laborer \$8.00/hour
 Ronnell J. Simmons, Cheektowaga, New York effective 6/23/11
 Craig M. Skierczynski, Cheektowaga, New York effective 6/23/11
 Justin P. Borowski, Cheektowaga, New York effective 7/4/11
 Daniel J. Woods \$8.00/hour effective 6/27/11

BE IT RESOLVED, that the following individuals be and hereby are hired as **PART-TIME EMPLOYEES** in the departments listed, not to exceed nineteen (19) hours on a weekly basis, in compliance with Civil Service Laws and Regulations as well as the provisions of the Town's collective bargaining agreement between the Town of Cheektowaga and the Town of Cheektowaga Employees Association:

BUILDING INSPECTION DEPARTMENT Clerk \$8.25/hour effective 7/5/11
 Cheryl A. Vargo, Cheektowaga, New York

POLICE DEPARTMENT Student Assistant \$7.25/hour effective 7/6/11
 Kelly A. Brzyski, Cheektowaga, New York

BE IT RESOLVED, that the following seasonal and/or part-time employees be and hereby are terminated as listed:

SANITATION DEPARTMENT
 Bryan M. Kazmierczak effective 6/21/11 (Laborer)
 Justin Borowski effective 6/21/11 (Laborer)

BUILDING INSPECTION DEPARTMENT
 Melinda Londos effective 5/28/11 (Clerk)

RESULT:	ADOPTED [UNANIMOUS]
MOVER:	Jeff Swiatek, Councilmember
SECONDER:	Mary Holtz, Supervisor
AYES:	Holtz, Jaworowicz, Swiatek, Rogowski, Zydel, Markel, Kaznowski



23. RESOLUTION 2011-396

Appoint Civil Officer

Sponsored By: Councilmember Jaworowicz, Councilmember Rogowski

WHEREAS, the Town Board of the Town of Cheektowaga, a duly constituted Town of the First Class, deems it necessary and proper to have a Civil Officer appointed possessing the powers and duties of a Constable in civil actions and proceedings only; and

WHEREAS, the Town has a police department duly established pursuant to law;
NOW, THEREFORE, BE IT

RESOLVED, that pursuant to the authority granted by Town Law Section (20(1)(a), Monique Geising of West Seneca, New York, be and is hereby appointed a Civil Officer of the Town, possessing all the powers of a Constable in civil actions and proceedings only; and BE IT FURTHER

RESOLVED, that said Monique Geising shall be paid no salary but shall be entitled to collect the statutory fees allowed by law in such civil actions and proceedings; and BE IT FURTHER

RESOLVED, that this appointment shall take effect on July 6, 2011 and shall continue for a term ending on December 31, 2011.

RESULT:	ADOPTED [UNANIMOUS]
MOVER:	Patricia Jaworowicz, Councilmember
SECONDER:	James Rogowski, Councilmember
AYES:	Holtz, Jaworowicz, Swiatek, Rogowski, Zydel, Markel, Kaznowski



24. RESOLUTION 2011-397

Appointments to Board of Ethics

Sponsored By: Supervisor Holtz, Councilmember Markel

WHEREAS, by resolution dated April 5, 1993, this Town Board adopted A Local Law Establishing a Board of Ethics (Local Law No.1 of the year 1993), which was amended by the adoption, on April 4, 1994, of A Local Law Amending the Board of Ethics Law (Local Law No.1 of the year 1994); and

WHEREAS, pursuant to such law, this Town Board appointed five members to serve on the Board of Ethics Committee; and

WHEREAS, there are presently two (2) vacancies of the Board of Ethics, and

WHEREAS, Kathleen E. Seibold and Dan G. Dallmann have expressed interest in serving on said Board; NOW, THEREFORE, BE IT

RESOLVED, that Kathleen E. Seibold of Cheektowaga, New York, be and hereby is appointed to the Board of Ethics of the Town of Cheektowaga effective immediately, and said appointment shall terminate on August 1, 2014; and BE IT FURTHER

RESOLVED, that Dan G. Dallmann of Cheektowaga, New York, be and hereby is appointed to the Board of Ethics of the Town of Cheektowaga effective immediately, and said appointment shall terminate on August 1, 2012; and BE IT FURTHER

RESOLVED, that said appointments are contingent upon execution of Agreements of Confidentiality; and be it further

RESOLVED, that the Supervisor be and hereby is authorized and directed to execute said Agreements of Confidentiality.

RESULT:	ADOPTED [UNANIMOUS]
MOVER:	Mary Holtz, Supervisor
SECONDER:	Charles Markel, Councilmember
AYES:	Holtz, Jaworowicz, Swiatek, Rogowski, Zydel, Markel, Kaznowski



25. RESOLUTION 2011-398

Appointment of Motor Equipment Operator - B (Non-Competitive/Permanent) Sanitation Department/Jeffrey Lempko

Sponsored By: Councilmember Swiatek, Supervisor Holtz

WHEREAS, a vacancy exists in the title of Motor Equipment Operator - B in the Sanitation Department; AND

WHEREAS, said title is in the Town of Cheektowaga Employees Association; AND

WHEREAS, the bargaining unit has agreed to waive the posting of said title; AND

WHEREAS, intradepartmental polling was conducted; AND

WHEREAS, Jeffrey Lempko, currently employed as a Laborer in the Sanitation Department, bid on said vacancy and meets the requirements for appointment; NOW, THEREFORE, BE IT

RESOLVED, that Jeffrey Lempko of Cheektowaga, New York, be and hereby is appointed to the title of Motor Equipment Operator - B in the Sanitation Department in accordance with the terms and conditions of the Town's collective bargaining agreement with the Town of Cheektowaga Employees Association effective July 6, 2011.

RESULT:	ADOPTED [UNANIMOUS]
MOVER:	Jeff Swiatek, Councilmember
SECONDER:	Mary Holtz, Supervisor
AYES:	Holtz, Jaworowicz, Swiatek, Rogowski, Zydel, Markel, Kaznowski



26. RESOLUTION 2011-399

Travel Authorization (Building and Plumbing Department)

Sponsored By: Councilmember Swiatek, Supervisor Holtz

WHEREAS, the Association of Towns 2011 Planning and Zoning Summer School is being held on July 19, 2011 in Amherst, New York; AND

WHEREAS, the following individuals have requested authorization to attend said school:

- Planner Daniel Ulatowski
- Planning Board Chair John Marriott
- Planning Board Member Ruth Casacci
- Planning Board Member Joan Adams
- Planning Board Member Sigmund Kucewicz
- Zoning Board Member Jane Wiercioch
- Zoning Board Member John Ptak; AND

WHEREAS, Planning Board Chairman John Marriott has submitted a request for travel authorization along with the proper paperwork in a timely manner; AND

WHEREAS, the total cost to the Town shall not exceed \$490; NOW, THEREFORE, BE IT

RESOLVED, that the aforementioned individuals be and hereby are authorized to attend the Association of Towns 2011 Planning and Zoning Summer School being held on July 19, 2011 in Amherst, New York.

RESULT:	ADOPTED [UNANIMOUS]
MOVER:	Jeff Swiatek, Councilmember
SECONDER:	Mary Holtz, Supervisor
AYES:	Holtz, Jaworowicz, Swiatek, Rogowski, Zydel, Markel, Kaznowski

V. Suspension of Rules

Motion by Supervisor Holtz; Seconded by Councilmember Rogowski to Suspend the Rules to Include the following two (2) Resolutions: 2011-400 and 2011-401. Motion Carried.
--



1. RESOLUTION 2011-400

Termination of General Mechanic

Sponsored By: Councilmember Swiatek, Supervisor Holtz

BE IT RESOLVED, that Christine L. Klaffka, a General Mechanic in the Facilities Department, be and hereby is terminated effective June 22, 2011.

RESULT:	ADOPTED [UNANIMOUS]
MOVER:	Jeff Swiatek, Councilmember
SECONDER:	Mary Holtz, Supervisor
AYES:	Holtz, Jaworowicz, Swiatek, Rogowski, Zydel, Markel, Kaznowski



2. RESOLUTION 2011-401

Approve Agreement with Buffalo ReUse, Inc.

Sponsored By: Supervisor Holtz, Councilmember Swiatek

WHEREAS, Buffalo Reuse, Inc., a domestic not-for-profit corporation located in Western New York, was established for the purpose of deconstructing buildings and re-using and reclaiming building materials to enhance the structural and aesthetic quality of existing homes in Western New York, and

WHEREAS, the activities of Buffalo Reuse, Inc. enable building materials, including fixtures, to be used elsewhere, thereby reducing the volume of waste disposed of by governmental entities, resulting in savings for the disposal of garbage, and

WHEREAAS, Buffalo Reuse, Inc. has requested permission to utilize a portion of the Cheektowaga Town Hall parking once a month to serve as a location where Town residents and others can drop off unused building materials and fixtures which would otherwise be thrown out, and

WHEREAS, this Town Board feels that said request would help the environment, our local economy and the taxpayers of the Town of Cheektowaga by reducing the amount of garbage disposed of by the Town, NOW, THEREFORE, BE IT

RESOLVED, that this Town Board hereby grants Buffalo Reuse, Inc. permission to utilize the Cheektowaga Town Hall parking lot once a month (fourth Saturday of each month) for a period of one (1) year for a drop-off site for said organization, and BE IT FURTHER

RESOLVED, that the Supervisor be and hereby is authorized and directed to execute an agreement with Buffalo Re-use, Inc. for the use of the Town Hall parking lot for a drop-off site, subject to the review and approval of the Town Attorney.

RESULT:	ADOPTED [UNANIMOUS]
MOVER:	Mary Holtz, Supervisor
SECONDER:	Jeff Swiatek, Councilmember
AYES:	Holtz, Jaworowicz, Swiatek, Rogowski, Zydel, Markel, Kaznowski

VI. Communications

A. Departmental Communications

1. Supervisor's Statement of Funds - May 2011
2. Minutes: Cheektowaga Traffic Safety Commission - May 17, 2011
3. Minutes: Cheektowaga Conservation Advisory Council - June 2, 2011

4. Town of Cheektowaga Statement of Changes in Cash Balances and Statements of Cash Receipts and Disbursements of the Receiver of Taxes and Assessments, the Town Clerk and the Town Justices for the Year Ended December 31, 2010 and Independent Auditor's Report
5. Building Permits - June 2011

B. General Communications

1. County of Erie: Road Opening - Youngs Road and Aero Drive Intersection Installation of Roundabout Towns of Cheektowaga and Amherst. the Intersection Will be Re-Opened to Traffic.
2. Notice of Claim: Jessica Fronczak Vs. Town of Cheektowaga
3. Notice of Claim: Velko B. Milev Vs. Town of Cheektowaga
4. Notice of Claim: Ronald Morsheimer Vs. Town of Cheektowaga

VII. Comments

A. Supervisor's Comments

B. Councilmember's Comments

C. Public Comments

VIII. Adjournment

Motion by Supervisor Holtz; Seconded by Councilmember Rogowski to adjourn the meeting at 7:51 PM.

Alice Magierski
Town Clerk

TOWN OF CHEEKTOWAGA

CREDIT CARD POLICY

I. PURPOSE

To establish criteria for the use of credit cards issued to employees of the Town of Cheektowaga for the purpose of conducting Town business.

II. OVERVIEW

The use of credit cards has proven to be a cost effective method of obtaining products and services for the Town. The use of credit cards also makes the Town more accountable by providing detailed purchase histories and other important record keeping and time saving information. Some travel and training costs may also be handled best through the credit card process.

III. PROCEDURE

For the credit card process to operate efficiently, a timely response to each of the elements of the procedure is required from those concerned. Failure to do so will create problems for the Finance Department in preparing for the month's end closeout. Employee absences should be anticipated and arrangements put in place so that the process flow will not be delayed.

A. Issuance of Credit Cards

1. Credit cards will only be issued to a Department Head or Department Head designated employees as determined by the Town Administrator (Director of Administration & Finance).
2. The employee must sign documentation verifying agreement to the conditions of use.
3. The Town Administrator will review the enrollment form, verify all information, and submit an application for a credit card to the Financial Institution.
4. Each enrollment form will contain spending limits for each transaction, for a daily total, and for a monthly total. These limits will be set by the Town Administrator based on existing Town policy as well as the requirements of the specific Town employee.
5. The card will be issued in the name of the employee, in care of the Town of Cheektowaga.

B. Use of the Credit Card

1. The employee who is issued the card is the only person authorized to use that card. The Cardholder may make transactions on behalf of others in their Department, however the Cardholder is responsible for all use of his/her card.
2. The credit card is to be used in the conduct of the Town's business only. The use of a Town credit card to acquire or purchase goods and services for other than official use of the Town is fraudulent use and may subject the employee to disciplinary action up to and including dismissal and/or criminal prosecution.
3. The following restrictions will apply to purchase limits:
 - a. The total value of a transaction shall not exceed a Cardholder's single purchase limit. Payment for a purchase WILL NOT be split into multiple transactions to stay within the single purchase limit.
 - b. Spending limits for the day and month will be adhered to.
4. The Cardholder will retain vendor's receipts and/or records of telephone, Internet, and/or mail orders and file for future reconciliation of the credit card statement.

C. Unauthorized Credit Card Use

The credit card SHALL NOT BE USED for the following:

- a. Personal purchases or identification.
- b. A purchase that exceeds the Cardholder's single, daily, and/or monthly purchase limit.
- c. Cash advances.

A Cardholder who makes unauthorized purchases will be liable for the total dollar amount of such unauthorized purchases, plus any administrative fees charged by the Bank or card company in connection with the misuse. The Cardholder will also be subject to disciplinary action, which may include termination.

D. Cardholder Record Keeping

1. Whenever a credit card purchase is made, either over-the-counter or by other means, documentation shall be obtained as proof of purchase. Such documentation will be used to verify the purchases listed on the Cardholder's monthly statement of account.

2. When the purchase is made over-the-counter, the Cardholder shall retain the invoice and "customer copy" of the charge receipt. The Cardholder is responsible for checking that the vendor lists the quantity, fully describes the item(s), and includes any tax prior to the Cardholder signing the slip. An invoice for any meal will include an itemized list of items purchased.
 3. When the purchase is made on the Internet, the Cardholder shall print a copy of the receipt and order confirmation before exiting the site.
 4. When a purchase is made over the telephone, the Cardholder shall have the vendor fax them a copy of the receipt.
 5. When the purchase is made by mail, the Cardholder shall retain all confirmations and shipping documentation.
 6. When an item is returned, the vendor shall issue the Cardholder a credit, which should appear on a subsequent statement. Under no circumstances should the Cardholder accept cash in lieu of a credit to the credit card account.
 7. Each transaction shall also be added to the Cardholder's Purchasing Log. The following information should be included:
 - a. Receipt date
 - b. Vendor name
 - c. Purchase amount
 - d. Budget account code
 - e. Description.
- E. Review of Monthly Statement
1. At the end of each billing cycle, the Cardholder shall receive his/her monthly statement of account that will list the Cardholder's transactions for that period.
 2. The Cardholder shall check each transaction listed against his/her purchasing log, receipts, and any shipping documents to verify the monthly statement. The original sales documents (packing slip, invoice, cash register tape, credit card slips, etc.) for all items listed on the monthly statement MUST be neatly attached, in transaction sequence, to the Purchasing Log, and submitted with the statement to Accounts Payable within five (5) business days of receiving the monthly statement.
- F. Payment of Credit Card Purchases
1. The Cardholder will reconcile the monthly statement received from the Credit Card Company with the receipts and sign as correct. If an item is returned and a credit voucher received, the Cardholder shall verify that this credit is reflected on the monthly statement.

- a. If purchased items are not listed on the monthly statement, the appropriate transaction documentation shall be **RETAINED** by the Cardholder until the next monthly statement. If the purchase or credit does not appear on the statement within 60 days after the date of purchase, the Cardholder shall notify the Town Administrator and the Finance Department.
 - b. If the item purchased by the use of the credit card is found to be unacceptable, the Cardholder is responsible for obtaining replacement or correction of the item as soon as possible. If the vendor has not replaced or corrected the item by the date the Cardholder receives his/her monthly statement, then the purchase of that item will be considered in dispute. The Cardholder should document the dispute on the Purchasing Log and attach it to the statement.
2. The Cardholder will review the reconciled statement, sign, and forward with receipts and Purchasing Log to Accounts Payable.
 3. Accounts Payable will review the documents for correctness, charge the proper accounts, and process the statement for payment.

G. Cardholder Security

1. It is the Cardholder's responsibility to safeguard the credit card and account number to the same degree that a Cardholder safeguards his/her personal credit information. A violation of this trust will result in that Cardholder having his/her card withdrawn and disciplinary action.
2. If the card is lost or stolen, the Cardholder shall immediately notify the credit card company, representatives are available 24 hours a day. The Town Administrator should also be notified.
3. A new card shall be promptly issued to the Cardholder after the reported loss or theft. A card that is subsequently found by the Cardholder after being reported lost shall be destroyed, and the Town Administrator notified.

H. Cardholder Separation

Prior to separation from the Town of Cheektowaga, the Cardholder shall surrender the credit card and current credit card proofs of purchase to the Town Administrator. Upon its receipt, the Town Administrator will follow the steps outlined under Review of Monthly Statement and Payment of Credit Card Purchases, and forward the card to Finance to be destroyed.

I. Revocation of Credit Card Privileges

1. The issuance of a credit card to an employee is done at the discretion of the Town Administrator.
2. Failure to comply with proper record keeping procedures as outlined in this policy will be cause to revoke the employee's credit card privilege.
3. Repeated loss or theft of any issued credit card will be cause to revoke the employee's credit and privilege. Failure to immediately report the theft/loss of a card upon discovery may also lead to revocation of the credit card privilege.



Town of Cheektowaga

Regular Meeting

~ Minutes ~

3301 Broadway
Cheektowaga, NY 14227
<http://www.town.cheektowaga.ny.us>

Alice Magierski
716-686-3400

Monday, July 18, 2011

6:45 PM

Council Chambers

I. Call to Order

6:45 PM Meeting called to order on July 18, 2011 at Council Chambers, 3301 Broadway St, Cheektowaga, NY.

Attendee Name	Organization	Title	Status	Arrived
Mary Holtz	Town of Cheektowaga	Supervisor	Absent	
Patricia Jaworowicz	Town of Cheektowaga	Councilmember	Present	
Jeff Swiatek	Town of Cheektowaga	Councilmember	Present	
James Rogowski	Town of Cheektowaga	Councilmember	Present	
Richard Zydel	Town of Cheektowaga	Councilmember	Present	
Charles Markel	Town of Cheektowaga	Councilmember	Present	
Stanley Kaznowski	Town of Cheektowaga	Councilmember	Present	

2. Additional Attendees

Thomas Adamczak, Supervising Building and Plumbing Inspector
John Marriott, Planning Board Chairman
William Pugh, Town Engineer
Kevin Schenk, Town Attorney
David Zack, Chief of Police

II. Public Comment Period 6:45 PM

III. Resolutions



1. RESOLUTION 2011-402

Transfer of Funds

Sponsored By: Councilmember Swiatek, Councilmember Kaznowski

BE IT RESOLVED, that the following transfer is hereby approved and made a part hereof;

GENERAL FUND

FROM: 100.1910.2665 Sale of Equipment \$ 5,110.00

TO: 100.7110.2304 Park Equipment \$ 5,110.00

RESULT:	ADOPTED [UNANIMOUS]
MOVER:	Jeff Swiatek, Councilmember
SECONDER:	Stanley Kaznowski, Councilmember
AYES:	Jaworowicz, Swiatek, Rogowski, Zydel, Markel, Kaznowski
ABSENT:	Mary Holtz



2. RESOLUTION 2011-403

Warrant

Sponsored By: Councilmember Swiatek, Councilmember Kaznowski

BE IT RESOLVED, that the following Vouchers & Warrants submitted to the Town of Cheektowaga prior to July 15, 2011 are hereby approved and made a part hereof;

GENERAL FUND	\$ 2,058,527.50
RISK RETENTION FUND	78,210.99
DEBT SERVICE FUND	173,650.00
HUD HOUSING REHABILITATION FUND	4,716.00
SPECIAL DISTRICTS FUND	786,003.17
HIGHWAY FUND	378,683.95
CAPITAL FUND	363,804.88
TRUST & AGENCY FUND	4,603.00
HUD CDBG FUND	530.95
PART TOWN FUND	98,459.96
	<u>98,459.96</u>
	\$ 3,947,190.40

RESULT:	ADOPTED [UNANIMOUS]
MOVER:	Jeff Swiatek, Councilmember
SECONDER:	Stanley Kaznowski, Councilmember
AYES:	Jaworowicz, Swiatek, Rogowski, Zydell, Markel, Kaznowski
ABSENT:	Mary Holtz



3. RESOLUTION 2011-404

Award of Bid - Boring of 21" Sanitary Sewer Under Dick Road/North Creek Drive

Sponsored By: Councilmember Kaznowski, Councilmember Zydel

WHEREAS, a Notice to Bidders was published for the Boring of a 21" Sanitary Sewer under Dick Road/North Creek Drive, which bids were duly received and opened on July 6, 2011, AND

WHEREAS, said bids were referred to the Town Engineer for analysis and tabulation, NOW, THEREFORE, BE IT

RESOLVED, that the contract for the Boring of a 21" Sanitary Sewer under Dick Road/North Creek Drive be awarded to:

Kandey Company, Inc.
19 Ransier Drive
West Seneca, New York 14224

for submission of the lowest bid meeting the requirements of the specifications in the amount of \$109,427.00, AND, BE IT FURTHER

RESOLVED, that funding for the subject project shall be chargeable to Account No. 500-1440-4542-5128.

RESULT:	ADOPTED [UNANIMOUS]
MOVER:	Stanley Kaznowski, Councilmember
SECONDER:	Richard Zydel, Councilmember
AYES:	Jaworowicz, Swiatek, Rogowski, Zydel, Markel, Kaznowski
ABSENT:	Mary Holtz



4. RESOLUTION 2011-405

Notice to Bidders - Renovations to the Anna Reinstein Library

Sponsored By: Councilmember Rogowski, Councilmember Markel

WHEREAS, by resolution dated May 4, 2009, the Town Board engaged the firm of Trautman Associates to prepare plans and specifications for window replacement to the Anna Reinstein Library located at 2580 Harlem Road in the Town of Cheektowaga, AND

WHEREAS, said plans and specifications have been completed enabling the solicitation of competitive bids in the field of General Construction Work pertaining to window and storefront replacement, NOW, THEREFORE, BE IT

RESOLVED, that the Town Clerk be directed to publish a Notice to Bidders for Renovations to the Anna Reinstein Library, 2580 Harlem Road, said notice to be published in THE CHEEKTOWAGA BEE, AND, BE IT FURTHER

RESOLVED, that sealed bids will be received on the 10th day of August, 2011 at 11:00 AM, at a public bid opening to be held in the Council Chambers in the Cheektowaga Town Hall.

NOTICE TO BIDDERS

NOTICE IS HEREBY GIVEN that sealed proposals will be received and considered by the Town Board of the Town of Cheektowaga, County of Erie, State of New York, on the 10th day of August, 2011 at 11:00 AM in the Town Hall, Town of Cheektowaga, for furnishing all labor, materials, tools, equipment and incidentals required for General Construction Work (window removal and replacement and associated asbestos abatement) for Renovations to the Anna Reinstein Library, 2580 Harlem Road, complete in place and ready for use in accordance with the Contract Documents, therefore, including Plans, Specifications, Instructions to Bidders, etc. prepared by Trautman Associates and approved by the Town Board of the Town of Cheektowaga, all of which are on file with the Town Engineer in his office at 275 Alexander Avenue, Cheektowaga, New York 14211.

Copies of the proposed Contract Documents, Plans, Specifications and Instructions to Bidders may be examined at the Town of Cheektowaga Engineering Department, 275 Alexander Avenue, Cheektowaga, New York 14211 and at the Town Clerk's Office, Broadway & Union Road, Cheektowaga, New York 14227. Copies may be secured at the Office of the Town Clerk upon payment of \$50.00 per set of documents. Deposits should be made in the form of a check made payable to the Town of Cheektowaga.

Any bidder returning such Plans and Specifications in good condition within 30 days following the award of the contract or the rejection of the bids will be refunded the full amount of the deposit. Similarly, non-bidders will be refunded one-half the deposit. Material suppliers and anyone returning the Plans and Specifications before the bid opening will also be classed as non-bidders. Any bidders requesting more than one set of Plans and Specifications may purchase the excess, but it is understood that they are not returnable.

All bids must be enclosed in a separate, sealed envelope and shall be addressed to the

Town Clerk of the Town of Cheektowaga, Town Hall, Broadway and Union Roads, Cheektowaga, New York 14227 and marked "Window Replacement at the Anna Reinstein Library".

The right to reject any and all bids, to waive any informalities in, or to make an award to other than the low bidder, should it be deemed to be in the best interest of the Town of Cheektowaga and in accordance with the law, are herewith reserved.

Each proposal must be accompanied by a certified check for a sum equal to five percent (5%) of the amount of the bid payable to the Town of Cheektowaga, New York, or bid bond with sufficient sureties to be approved by the Attorney for the Town of Cheektowaga, New York, in a sum equal to five percent (5%) of the amount of the bid, conditioned that, if his proposal is accepted, he will enter into a contract for the same, and that he will execute such further security as may be required for the faithful performance of the Contract.

No bidder may withdraw his bid within forty-five days after the date set for the opening thereof, but may withdraw same any time prior to the scheduled date for the opening of bids.

The successful bidder will be required to furnish a Performance Bond and Labor and Material Payment Bond acceptable to the Owner, in an amount equal to the contract award.

Attention of the bidders is further called to Section 103-d of the General Municipal Law which requires a bidder's Certificate of Non-Collusion. Such certificate is part of the bid or proposal form and unless complied with, such bid will not be accepted.

The Town of Cheektowaga is an exempt organization under the Tax Law and is exempt from payment of sales and compensating use taxes in the State of New York and cities and counties of the State on all materials which are to be incorporated into the project, pursuant to the provisions of the Contract. These taxes are not to be included in the bid.

A Pre-Bid Conference will be held on August 1, 2011 at the project site at 2580 Harlem Road at 10:00 AM.

BY ORDER OF THE TOWN OF CHEEKTOWAGA, ERIE COUNTY,
STATE OF NEW YORK

Alice Magierski
Town Clerk

DATED: July 18, 2011
PUBLISHED: July 21, 2011

RESULT:	ADOPTED [UNANIMOUS]
MOVER:	James Rogowski, Councilmember
SECONDER:	Charles Markel, Councilmember
AYES:	Jaworowicz, Swiatek, Rogowski, Zydel, Markel, Kaznowski
ABSENT:	Mary Holtz



5. RESOLUTION 2011-406

Adoption of Town Safety Manual

Sponsored By: Councilmember Swiatek, Councilmember Kaznowski

WHEREAS, the Town of Cheektowaga is committed to workplace safety for our employees; AND

WHEREAS, in order to protect our employees, it is necessary that the Town of Cheektowaga adopt workplace safety rules which all employees must follow; AND

WHEREAS, the Coordinator of Employee Relations, together with the Town's Loss Control consultant, have drafted a set of safety rules, policies and guidelines designed to insure the health and safety of Town employees and the general public; NOW, THEREFORE, BE IT

RESOLVED, that this Town Board hereby approves and adopts the attached set of workplace safety rules, policies and guidelines for use by all Town employees which shall be effective immediately.

Attachments:

Safety Policy (PDF)

RESULT: ADOPTED [UNANIMOUS]
MOVER: Jeff Swiatek, Councilmember
SECONDER: Stanley Kaznowski, Councilmember
AYES: Jaworowicz, Swiatek, Rogowski, Zydel, Markel, Kaznowski
ABSENT: Mary Holtz



6. RESOLUTION 2011-407

Approve Settlement of Claim Against Castricone Contracting, Inc.

Sponsored By: Councilmember Swiatek, Councilmember Zydel

WHEREAS, the Town of Cheektowaga entered into a contract with Castricone Contractors, Inc., for certain work and improvements to be performed at the Cedar Grove Heights Project Stage II, Phase IV; and

WHEREAS, as a result of the non-performance or unacceptable work of Castricone, the Town was required to enter into a contract with a new contractor which resulted in the Town expending an additional amount of \$19,975.99 to complete the work; and

WHEREAS, the Town made a claim against the bonding company for Castricone Contractors, Inc., and said bonding company went into bankruptcy; and

WHEREAS, the Town then made a claim against the New York Liquidation Bureau and negotiated said claim with their adjustors, and after extensive and protracted communication with them, they have agreed to pay the entire original claim of the Town in the amount of \$19,975.99, but will not pay interest on said sum; and

WHEREAS, considering the length of time this claim has been in negotiation, and after a determination that the New York Liquidation Bureau will under no circumstances pay interest on said sum and further negotiation or litigation will not yield a different result, it is the opinion of the Town Attorney that said sum be accepted in full settlement; NOW THEREFORE, BE IT

RESOLVED, that this Town Board hereby approves the offer of the New York Liquidation Bureau on behalf of Castricone Contractors, Inc., and agrees to accept the sum of \$19,975.99 in full satisfaction of the Town's claim; and BE IT FURTHER

RESOLVED, that the Supervisor is authorized to execute any documents necessary to effect said settlement, subject to prior approval by the Town Attorney.

RESULT:	ADOPTED [UNANIMOUS]
MOVER:	Jeff Swiatek, Councilmember
SECONDER:	Richard Zydel, Councilmember
AYES:	Jaworowicz, Swiatek, Rogowski, Zydel, Markel, Kaznowski
ABSENT:	Mary Holtz



7. RESOLUTION 2011-408

Amend Community Development 2011 Annual Plan

Sponsored By: Councilmember Markel, Councilmember Kaznowski

WHEREAS, the Town of Cheektowaga has received notice from the Department of Housing and Urban Development that it's allocation of Community Development Block Grant funds for the 2011 program year has been reduced by the amount of \$ 178,817 to \$ 971,310, thereby requiring changes to the original Annual Action Plan budget adopted by the Town Board on February 7, 2011, AND

WHEREAS, the Town is required to amend its Annual Community Development Block Grant Action Plan for the 2011 program year pursuant to the attached Community Development Block Grant Program Amendment Report, AND

WHEREAS, citizens and interested parties were provided the opportunity to comment on the proposed amendment pursuant to the Citizen Participation Plan previously adopted by the Town Board, AND

WHEREAS, the Director of Community Development recommends approval of the proposed amendments, NOW, THEREFORE BE IT

RESOLVED, that the Town Board hereby amends the Town of Cheektowaga's Annual Plan / Final Statement on the Use of Community Development Block Grant Funds for the 2011 program year pursuant to the attached Community Development Block Grant Final Statement Amendment Report and hereby authorizes submission of said changes to the Department of Housing and Urban Development.

Town of Cheektowaga
Community Development Block Grant Program
Annual Plan / Final Statement Amendment Report
2011 - #1

Approved July 18, 2011

The Town of Cheektowaga's Annual Plan / Final Statement on the Use of Community Development Block Grant and HOME Investment Partnership Funds is amended as follows:

(a) fiscal year 2011 CDBG funding has been revised due to a funding decrease in the amount of \$178,817 to \$971,310, requiring changes to the original Action Plan Budget adopted by the Town Board on February 7, 2011. The following activities are proposed to be cancelled: (1) Demolition-\$4,000; (2) Senior Citizen Program-\$10,000; (3) Sloan-Demolition of Railroad Building-\$10,000.

(b) Funding for the following activities have been changed as indicated: (1) Single Family Housing Rehab-reduced by \$10,577 to \$250,000; (2) Multi-Family Housing Rehab-reduced by \$22,195 to \$17,805; (3) Housing Rehab Activity Delivery Costs-Inspections-reduced by \$60,000 (housing rehab inspections) to \$230,000; (4) Acquisition-reduced by \$40,000 to \$30,000; (5) Police Foot Patrols-reduced by \$4,000 to \$38,000; (6) Housing Counseling Services-reduced by \$4,500 to \$3,500; (7) Fair Housing-reduced by \$700 to \$3,300; (8) Weatherization-reduced by \$1,000 to \$5,000; (9) Village of Depew-Total funding reduced by \$16,160 to \$87,700 (Sidewalk

Replacement reduced by \$16,160 to \$24,700); (10) Village of Sloan-Total funding reduced by \$5,710 to \$30,980 (Demolition of Railroad Building Cancelled [(a)(3) above]-\$10,000); Funding for Sloan Drainage and Sewer Improvements increased by \$4,290 to \$17,400; (11) Contingency Funding-reduced by \$4,975 to \$10,025; (12)

Environmental Hazard Testing-increased by \$5,000 to \$20,000.

(c) Additionally, the Town=s allocation of HOME Investment Partnership Funds has been reduced By \$45,781 to \$340,625. Following is the proposed FY 2011 HOME Program Budget: 1) Acquisition-RehabilitationBCHDO Project-\$164,234; (2) Housing Rehabilitation-\$165,391; (3) First-Time Homebuyer Program-\$5,000; and, (4) Administration and Program Delivery Costs-\$6,000.

RESULT:	ADOPTED [UNANIMOUS]
MOVER:	Charles Markel, Councilmember
SECONDER:	Stanley Kaznowski, Councilmember
AYES:	Jaworowicz, Swiatek, Rogowski, Zydel, Markel, Kaznowski
ABSENT:	Mary Holtz



8. RESOLUTION 2011-409

Authorization for Purchase - NYSDOT Cabinets

Sponsored By: Councilmember Jaworowicz, Councilmember Rogowski

WHEREAS, the Cheektowaga Traffic Maintenance Division, under the authority of the Cheektowaga Police Department, oversees the Town of Cheektowaga's traffic signal infrastructure, AND

WHEREAS, due to aging and usage, the need has arisen to replace current traffic signal controller cabinets, AND

WHEREAS, Safetran, 3360 East LaPalma Avenue, Anaheim, California 92806, offers NYSDOT approved Model 330R traffic signal controller cabinets under NYS Contract# PC63049, AND

WHEREAS, the Cheektowaga Traffic Maintenance Division is requesting to purchase four (4) Model 330R traffic signal controller cabinets at a cost of \$3,284.47 each for a grand total of \$13,137.88, AND

WHEREAS, money has been appropriated for this purchase out of budget lines #100-3310-4476 and #990-5182-4432, NOW, THEREFORE, BE IT

RESOLVED, that the Town Board hereby authorizes the purchase of four (4) Model 330R Traffic Signal Controller Cabinets for a total cost of \$13,137.88 from:

Safetran
3360 East La Palma Avenue
Anaheim, CA 92806-2814

RESULT:	ADOPTED [UNANIMOUS]
MOVER:	Patricia Jaworowicz, Councilmember
SECONDER:	James Rogowski, Councilmember
AYES:	Jaworowicz, Swiatek, Rogowski, Zydell, Markel, Kaznowski
ABSENT:	Mary Holtz



9. RESOLUTION 2011-410

Authorization for Purchase - Mobile Video Storage

Sponsored By: Councilmember Jaworowicz, Councilmember Rogowski

WHEREAS, the Cheektowaga Police Department Central Records Division, due to the Town of Cheektowaga's Records Retention Policy, has found it necessary to procure additional storage space for mobile videos recorded by its police officers, AND

WHEREAS, Synergy Global Solutions, 1100 Pittsford-Victor Road, Pittsford, New York 14534 has submitted a quotation for the Nexsan SATABoy Storage Solution System which includes 16 TB of Storage Expandable to 28 TB, which will provide long-term storage, AND

WHEREAS, Synergy Global Solutions offers special pricing assigned from Nexsan to the Cheektowaga Police Department under Opportunity #L64875; AND

WHEREAS, the cost of the additional storage is \$12,860.00 and on-site 3 year repairs by the next business day is \$2,757.00, AND

WHEREAS, money has been appropriated for this purchase out of budget lines #100-3120-2205 (JAG Stimulus Grant 2009) and 100-3120-2204, NOW, THEREFORE, BE IT

RESOLVED, that the Town Board hereby authorizes the purchase of the Nexsan SATABoy Storage Solution System and on-site 3 year repairs by next business day at a total cost of \$15,617.00 from:

Synergy Global Solutions, Inc.
1100 Pittsford-Victor Road
Pittsford, New York 14534

RESULT:	ADOPTED [UNANIMOUS]
MOVER:	Patricia Jaworowicz, Councilmember
SECONDER:	James Rogowski, Councilmember
AYES:	Jaworowicz, Swiatek, Rogowski, Zydell, Markel, Kaznowski
ABSENT:	Mary Holtz



10. RESOLUTION 2011-411

Approve Purchase of One (1) Bobcat Skid-SteerLoader

Sponsored By: Councilmember Swiatek, Councilmember Rogowski

WHEREAS, the Highway Department, have requested authorization to purchase One (1) S650 bobcat Skid-Steer Loader as specified in New York State OGS Contracts PC64705 AND

WHEREAS, funds for said purchase have been budgeted and are available under account number 300-5130-2407, NOW THEREFORE BE IT,

RESOLVED, that the Town Board hereby authorizes the purchase of One (1) S650 Bobcat Skid-Steer Loader in the amount of \$16,394.00. Amount reflects trade-in value of 1997 Newholland LX865.

RESULT:	ADOPTED [UNANIMOUS]
MOVER:	Jeff Swiatek, Councilmember
SECONDER:	James Rogowski, Councilmember
AYES:	Jaworowicz, Swiatek, Rogowski, Zydel, Markel, Kaznowski
ABSENT:	Mary Holtz



11. RESOLUTION 2011-412

Approve Purchase of One (1) S650 Bobcat Skid-Steer Loader

Sponsored By: Councilmember Swiatek, Councilmember Rogowski

WHEREAS, the Highway Department, have requested authorization to purchase One (1) S650 Bobcat Skid-Steer Loader as specified in New York State OGS Contracts PC64705 AND

WHEREAS, funds for said purchase have been budgeted and are available under account number 300-5130-2407, NOW THEREFORE BE IT,

RESOLVED, that the Town Board hereby authorizes the purchase of One (1) S650 Bobcat Skid-Steer Loader in the amount of \$36,742.00 from:

Bobcat of Buffalo, Lockport, NY
6511 South Transit Road
Lockport, NY 14094-6329

RESULT:	ADOPTED [UNANIMOUS]
MOVER:	Jeff Swiatek, Councilmember
SECONDER:	James Rogowski, Councilmember
AYES:	Jaworowicz, Swiatek, Rogowski, Zydel, Markel, Kaznowski
ABSENT:	Mary Holtz



12. RESOLUTION 2011-413

Authorize Disposal Obsolete Computer and Electronics Equipment

Sponsored By: Councilmember Markel, Councilmember Swiatek

WHEREAS, the Town wishes to dispose of a number of various computers, monitors, printers, drives, and fax machines, and other electronic items which are obsolete, unusable, and have no market value, all of which contain hazardous materials (i.e., lead, mercury, etc.) and must be disposed of in an environmentally sound manner; and

WHEREAS, the disposal of such property is authorized by Section 64 of the Town Law of the State of New York; and

WHEREAS, Edward Arnold Scrap Processors, Inc., ("Arnold") of Corfu, New York, an electronics recycling company, will pick-up said equipment and dispose of same in full compliance with all government regulations applicable to the disposal of hazardous waste, and will pay the Town \$.05 per pound for recovered materials (except CRT's); NOW, THEREFORE, BE IT

RESOLVED, that the Town hereby authorizes Edward Arnold Scrap Processors, Inc., to take possession of the equipment as shown on the attached list, and dispose of same in full compliance with all applicable federal and state regulations governing the disposal of hazardous waste; and BE IT FURTHER

RESOLVED, that, subject to review and approval by the Town Attorney, the Supervisor of the Town of Cheektowaga be and hereby is authorized to execute any document necessary effect the proper disposal of said equipment.

Attachments:

OBSOLETE COMPUTER DISPOSAL LIST July 2011 (PDF)

RESULT: ADOPTED [UNANIMOUS]
MOVER: Charles Markel, Councilmember
SECONDER: Jeff Swiatek, Councilmember
AYES: Jaworowicz, Swiatek, Rogowski, Zydel, Markel, Kaznowski
ABSENT: Mary Holtz



13. RESOLUTION 2011-414

Special Event - Combat Sports Softball Tournament

Sponsored By: Councilmember Rogowski, Councilmember Zydel

WHEREAS, by resolution dated May 1, 1995, this Town Board adopted a Special Events policy, which requires anyone wishing to hold a special event in the Town to file an application and supporting documentation, fees, etc. to the Town Clerk prior to the special event, and

WHEREAS, the Combat Sports Softball has made application to hold its "Softball Tournament" in Stiglmeier Park on Saturday, August 27, 2011, (rain date: Sunday, August 28th) and

WHEREAS, this Board has reviewed the aforementioned application, which application has been approved by the Police Department and the Department of Parks, Recreation & Youth Services, and has no objection to same, and

WHEREAS, due to the nature of the event, this Town Board hereby waives the following requirements:

1. Submittal of plan for sanitary facilities;
2. Submittal of site plan;
3. Submittal of Security Plan; submittal of Fire Prevention/Emergency Services Plan;

NOW, THEREFORE, BE IT

RESOLVED, that this Town Board hereby approves the aforementioned application of the Combat Sports Softball for the aforementioned "Softball Tourney" to be held in Stiglmeier Park on Saturday, August 27, 2011 (rain date: Sunday August 28th,).

RESULT:	WITHDRAWN
----------------	------------------



14. RESOLUTION 2011-415

Special Event - HSBC Technology Services - Company Picnic

Sponsored By: Councilmember Rogowski, Councilmember Zydel

WHEREAS, by resolution dated May 1, 1995, this Town Board adopted a Special Events policy, which requires anyone wishing to hold a special event in the Town to file an application and supporting documentation, fees, etc. to the Town Clerk prior to the special event, and

WHEREAS, the HSBC Technology Services has made application to hold its company picnic in Cheektowaga Town Park at the Lion's Pavilion on August 12, 2011, from 9:00 a.m. to 6:00 p.m. and

WHEREAS, this Board has reviewed the aforementioned application, which application has been approved by the Police Department, Building Department, Facilities Department, Highway Department, and the Youth and Recreation Department, and has no objection to same, and

WHEREAS, due to the nature of the event, this Town Board hereby waives the following requirements:

1. Submittal of plan for sanitary facilities;
2. Submittal of site plan;
3. Submittal of Security Plan;
4. Submittal of Fire Prevention/Emergency Services Plan;

NOW, THEREFORE, BE IT

RESOLVED, that this Town Board hereby approves the aforementioned application of the HSBC Technology Services for the aforementioned picnic to be held in Cheektowaga Town Park on August 12, 2011, from 9:00 a.m. to 6:00 p.m.

RESULT:	ADOPTED [UNANIMOUS]
MOVER:	James Rogowski, Councilmember
SECONDER:	Richard Zydel, Councilmember
AYES:	Jaworowicz, Swiatek, Rogowski, Zydel, Markel, Kaznowski
ABSENT:	Mary Holtz



15. RESOLUTION 2011-416

Special Event - Cheektowaga Oldtimers League

Sponsored By: Councilmember Rogowski, Councilmember Zydel

WHEREAS, by resolution dated May 1, 1995, this Town Board adopted a Special Events policy, which requires anyone wishing to hold a special event in the Town to file an application and supporting documentation, fees, etc. to the Town Clerk prior to the special event, and

WHEREAS, the Cheektowaga Oldtimers League has made application to hold its annual "Super Sunday Softball Playoffs" at Stiglmeier Park Diamond 3 on Sunday, August 28th, 2011 from 11:00 a.m. - 5:30 p.m.; AND

WHEREAS, this Board has reviewed the aforementioned application, which application has been approved by the Cheektowaga Police Department, Parks Department and Highway Department and has no objection to same, and

WHEREAS, due to the nature of the event, this Town Board hereby waives the following requirements:

2. Submittal of plan for sanitary facilities;
3. Submittal of site plan;
4. Submittal of Security Plan;
5. Submittal of Fire Prevention/Emergency Services Plan.

NOW, THEREFORE, BE IT

RESOLVED, that this Town Board hereby approves the aforementioned application of the Cheektowaga Oldtimers League for its annual "Super Sunday Softball Playoffs" at Stiglmeier Park Diamond 3 on Sunday, August 28th, 2011.

RESULT:	ADOPTED [UNANIMOUS]
MOVER:	James Rogowski, Councilmember
SECONDER:	Richard Zydel, Councilmember
AYES:	Jaworowicz, Swiatek, Rogowski, Zydel, Markel, Kaznowski
ABSENT:	Mary Holtz



16. RESOLUTION 2011-417

Unsafe-Unsecured/44A Windwood Court

Sponsored By: Councilmember Markel, Councilmember Kaznowski

WHEREAS, Town of Cheektowaga Law for the Administration and Enforcement of the Codes of New York State; and the Property Maintenance Code of New York State require that all vacant structures and premises shall be maintained in clean, safe, secure and sanitary conditions so as not to cause a blighting problem or adversely affect the public health or safety and all nuisances abated, AND

WHEREAS, the Town of Cheektowaga has received notification of an unsafe structure and premises located at 44A Windwood Court, Cheektowaga, New York SBL# 91.14-1-14 that is a danger to the safety of others, and records kept by the Assessors Office identify Jacob Bullis, 44A Windwood Court, Cheektowaga, New York 14225, as the owner AND

WHEREAS, an inspection of such premises was conducted at 44A Windwood Court, by the Housing and Neighborhood Preservation Office, AND

WHEREAS, such inspection found the premises to be deteriorated, vacant, a hazard, and a danger to the safety and well being of others, AND

WHEREAS, the Town of Cheektowaga Housing and Neighborhood Preservation Office properly notified the property owner in accordance with the Town of Cheektowaga Law for the Administration and Enforcement of the Codes of New York State, and the owner failed to take actions to safeguard the premises, AND

WHEREAS, these conditions require the Town of Cheektowaga Housing and Neighborhood Preservation Office to take immediate steps to safeguard the premises to protect the health and safety of others and abate all nuisances, NOW, THEREFORE BE IT

RESOLVED, that pursuant to Section 70-7A.(5) and Section 70-8 of the Town of Cheektowaga Law for the Administration and Enforcement of the Codes of New York State that the vacant structure premises be safeguarded and all nuisances abated; and all costs incurred be assessed against the property hereinbefore described

RESULT:	ADOPTED [UNANIMOUS]
MOVER:	Charles Markel, Councilmember
SECONDER:	Stanley Kaznowski, Councilmember
AYES:	Jaworowicz, Swiatek, Rogowski, Zydel, Markel, Kaznowski
ABSENT:	Mary Holtz



17. RESOLUTION 2011-418

Unsafe-Unsecured/141 Haller Avenue

Sponsored By: Councilmember Markel, Councilmember Kaznowski

WHEREAS, Town of Cheektowaga Law for the Administration and Enforcement of the Codes of New York State; and the Property Maintenance Code of New York State require that all vacant structures and premises shall be maintained in clean, safe, secure and sanitary conditions so as not to cause a blighting problem or adversely affect the public health or safety and all nuisances abated, AND

WHEREAS, the Town of Cheektowaga has received notification of an unsafe structure and premises located at 141 Haller Avenue, Cheektowaga, New York SBL# 101.52-4-20 that is a danger to the safety of others, and records kept by the Assessors Office identify Tung Nguyen, 1116 Kenmore Avenue, Buffalo, New York 14216, as the owner AND

WHEREAS, an inspection of such premises was conducted at 141 Haller Avenue, by the Housing and Neighborhood Preservation Office, AND

WHEREAS, such inspection found the premises to be deteriorated, vacant, a hazard, and a danger to the safety and well being of others, AND

WHEREAS, the Town of Cheektowaga Housing and Neighborhood Preservation Office properly notified the property owner in accordance with the Town of Cheektowaga Law for the Administration and Enforcement of the Codes of New York State, and the owner failed to take actions to safeguard the premises, AND

WHEREAS, these conditions require the Town of Cheektowaga Housing and Neighborhood Preservation Office to take immediate steps to safeguard the premises to protect the health and safety of others and abate all nuisances, NOW, THEREFORE BE IT

RESOLVED, that pursuant to Section 70-7A.(5) and Section 70-8 of the Town of Cheektowaga Law for the Administration and Enforcement of the Codes of New York State that the vacant structure premises be safeguarded and all nuisances abated; and all costs incurred be assessed against the property hereinbefore described

RESULT:	ADOPTED [UNANIMOUS]
MOVER:	Charles Markel, Councilmember
SECONDER:	Stanley Kaznowski, Councilmember
AYES:	Jaworowicz, Swiatek, Rogowski, Zydel, Markel, Kaznowski
ABSENT:	Mary Holtz



18. RESOLUTION 2011-419

Unsafe-Unsecured/69 Bernice Drive

Sponsored By: Councilmember Markel, Councilmember Kaznowski

WHEREAS, Town of Cheektowaga Law for the Administration and Enforcement of the Codes of New York State; and the Property Maintenance Code of New York State require that all vacant structures and premises shall be maintained in clean, safe, secure and sanitary conditions so as not to cause a blighting problem or adversely affect the public health or safety and all nuisances abated, AND

WHEREAS, the Town of Cheektowaga has received notification of an unsafe structure and premises located at 69 Bernice Drive, Cheektowaga, New York SBL# 103.05-8-13 that is a danger to the safety of others, and records kept by the Assessors Office identify Susan Lopez, 69 Bernice, Cheektowaga, New York 14225, as the owner AND

WHEREAS, an inspection of such premises was conducted at 69 Bernice Drive, by the Housing and Neighborhood Preservation Office, AND

WHEREAS, such inspection found the premises to be deteriorated, vacant, a hazard, and a danger to the safety and well being of others, AND

WHEREAS, the Town of Cheektowaga Housing and Neighborhood Preservation Office properly notified the property owner in accordance with the Town of Cheektowaga Law for the Administration and Enforcement of the Codes of New York State, and the owner failed to take actions to safeguard the premises, AND

WHEREAS, these conditions require the Town of Cheektowaga Housing and Neighborhood Preservation Office to take immediate steps to safeguard the premises to protect the health and safety of others and abate all nuisances, NOW, THEREFORE BE IT

RESOLVED, that pursuant to Section 70-7A.(5) and Section 70-8 of the Town of Cheektowaga Law for the Administration and Enforcement of the Codes of New York State that the vacant structure premises be safeguarded and all nuisances abated; and all costs incurred be assessed against the property hereinbefore described

RESULT:	ADOPTED [UNANIMOUS]
MOVER:	Charles Markel, Councilmember
SECONDER:	Stanley Kaznowski, Councilmember
AYES:	Jaworowicz, Swiatek, Rogowski, Zydel, Markel, Kaznowski
ABSENT:	Mary Holtz



19. RESOLUTION 2011-420

Minor Demolition/89 Mayberry Dr. East

Sponsored By: Councilmember Markel, Councilmember Kaznowski

WHEREAS, Town of Cheektowaga Law for the Administration and Enforcement of the Codes of New York State; and the Property Maintenance Code of New York State require that all vacant structures and premises shall be maintained in clean, safe, secure and sanitary conditions so as not to cause a blighting problem or adversely affect the public health or safety and all nuisances abated, AND

WHEREAS, the Town of Cheektowaga has received notification of an unsafe structure and premises located at 89 Mayberry Dr. East, Cheektowaga, New York SBL# 125.05-3-8 that is a danger to the safety of others, and records kept by the Assessors Office identify Anthony & Joyce Dinanno, 89 Mayberry Dr. East, Cheektowaga, New York 14227, as the owner AND

WHEREAS, an inspection of such premises was conducted at 89 Mayberry Dr. East, by the Housing and Neighborhood Preservation Office, AND

WHEREAS, such inspection found the premises to be deteriorated, vacant, a hazard, and a danger to the safety and well being of others, AND

WHEREAS, the Town of Cheektowaga Housing and Neighborhood Preservation Office properly notified the property owner in accordance with the Town of Cheektowaga Law for the Administration and Enforcement of the Codes of New York State, and the owner failed to take actions to safeguard the premises, AND

WHEREAS, these conditions require the Town of Cheektowaga Housing and Neighborhood Preservation Office to take immediate steps to safeguard the premises to protect the health and safety of others and abate all nuisances, NOW, THEREFORE BE IT

RESOLVED, that pursuant to Section 70-7A.(5) and Section 70-8 of the Town of Cheektowaga Law for the Administration and Enforcement of the Codes of New York State that the vacant structure premises be safeguarded and all nuisances abated; and all costs incurred be assessed against the property hereinbefore described

RESULT:	ADOPTED [UNANIMOUS]
MOVER:	Charles Markel, Councilmember
SECONDER:	Stanley Kaznowski, Councilmember
AYES:	Jaworowicz, Swiatek, Rogowski, Zydel, Markel, Kaznowski
ABSENT:	Mary Holtz



20. RESOLUTION 2011-421

Minor Demolition-Stagnant Pool/796 Cayuga Creek Rd

Sponsored By: Councilmember Markel, Councilmember Kaznowski

WHEREAS, Town of Cheektowaga Law for the Administration and Enforcement of the Codes of New York State; and the Property Maintenance Code of New York State require that all vacant structures and premises shall be maintained in clean, safe, secure and sanitary conditions so as not to cause a blighting problem or adversely affect the public health or safety and all nuisances abated, AND

WHEREAS, the Town of Cheektowaga has received notification of an unsafe structure and premises located at 796 Cayuga Creek Road, Cheektowaga, New York SBL# 113.15-3-18.2 that is a danger to the safety of others, and records kept by the Assessors Office identify Lemman Brothers Holdings Inc. 10350 Park Meadow Drive, Mailstop 42006, Littleton, CO 80124, as the owner AND

WHEREAS, an inspection of such premises was conducted at 796 Cayuga Creek Road, by the Housing and Neighborhood Preservation Office, AND

WHEREAS, such inspection found the premises to be deteriorated, vacant, a hazard, and a danger to the safety and well being of others, AND

WHEREAS, the Town of Cheektowaga Housing and Neighborhood Preservation Office properly notified the property owner in accordance with the Town of Cheektowaga Law for the Administration and Enforcement of the Codes of New York State, and the owner failed to take actions to safeguard the premises, AND

WHEREAS, these conditions require the Town of Cheektowaga Housing and Neighborhood Preservation Office to take immediate steps to safeguard the premises to protect the health and safety of others and abate all nuisances, NOW, THEREFORE BE IT

RESOLVED, that pursuant to Section 70-7A.(5) and Section 70-8 of the Town of Cheektowaga Law for the Administration and Enforcement of the Codes of New York State that the vacant structure premises be safeguarded and all nuisances abated; and all costs incurred be assessed against the property hereinbefore described

RESULT:	ADOPTED [UNANIMOUS]
MOVER:	Charles Markel, Councilmember
SECONDER:	Stanley Kaznowski, Councilmember
AYES:	Jaworowicz, Swiatek, Rogowski, Zydel, Markel, Kaznowski
ABSENT:	Mary Holtz



21. RESOLUTION 2011-422

Minor Demolition-Stagnant Pool/47 Barbados Dr

Sponsored By: Councilmember Markel, Councilmember Kaznowski

WHEREAS, Town of Cheektowaga Law for the Administration and Enforcement of the Codes of New York State; and the Property Maintenance Code of New York State require that all vacant structures and premises shall be maintained in clean, safe, secure and sanitary conditions so as not to cause a blighting problem or adversely affect the public health or safety and all nuisances abated, AND

WHEREAS, the Town of Cheektowaga has received notification of an unsafe structure and premises located at 47 Barbados Drive, Cheektowaga, New York SBL# 125.06-20-5 that is a danger to the safety of others, and records kept by the Assessors Office identify Donald W. Budziszewski, 47 Barbados Dr., Cheektowaga, New York 14227, as the owner AND

WHEREAS, an inspection of such premises was conducted at 47 Barbados Drive, by the Housing and Neighborhood Preservation Office, AND

WHEREAS, such inspection found the premises to be deteriorated, vacant, a hazard, and a danger to the safety and well being of others, AND

WHEREAS, the Town of Cheektowaga Housing and Neighborhood Preservation Office properly notified the property owner in accordance with the Town of Cheektowaga Law for the Administration and Enforcement of the Codes of New York State, and the owner failed to take actions to safeguard the premises, AND

WHEREAS, these conditions require the Town of Cheektowaga Housing and Neighborhood Preservation Office to take immediate steps to safeguard the premises to protect the health and safety of others and abate all nuisances, NOW, THEREFORE BE IT

RESOLVED, that pursuant to Section 70-7A.(5) and Section 70-8 of the Town of Cheektowaga Law for the Administration and Enforcement of the Codes of New York State that the vacant structure premises be safeguarded and all nuisances abated; and all costs incurred be assessed against the property hereinbefore described

RESULT:	ADOPTED [UNANIMOUS]
MOVER:	Charles Markel, Councilmember
SECONDER:	Stanley Kaznowski, Councilmember
AYES:	Jaworowicz, Swiatek, Rogowski, Zydel, Markel, Kaznowski
ABSENT:	Mary Holtz



22. RESOLUTION 2011-423

Youth & Recreation Termination

Sponsored By: Councilmember Zydel, Councilmember Rogowski

BE IT RESOLVED that the individuals listed below be and hereby are terminated in the Department of Youth & Recreational Services, effective as indicated:

Evin Bernard	Never worked	14215
Jonathan Klein	Never worked	14227
Jennifer Merkling	7/1/11	14043
Edward Pyszczynski	6/7/11	14227

Motion by Councilmember Rogowski; Seconded by Councilmember Kaznowski to waive the reading of names for the following three (3) Resolutions: 2011-423; 2011-424; and 2011-425. Motion Carried.

RESULT: ADOPTED [UNANIMOUS]
MOVER: Richard Zydel, Councilmember
SECONDER: James Rogowski, Councilmember
AYES: Jaworowicz, Swiatek, Rogowski, Zydel, Markel, Kaznowski
ABSENT: Mary Holtz



23. RESOLUTION 2011-424

Youth & Recreation Hiring/Transfers

Sponsored By: Councilmember Zydel, Councilmember Rogowski

BE IT RESOLVED that the individuals listed below be and hereby are hired and/or transferred, as indicated, in the Department of Youth & Recreational Services, effective immediately:

Recreation Attendant - 7310.1810 - \$7.25 - Seasonal - Retro to 6/30/11

Tracey Marlinski 14227

Brandon Rappold 14225

Lifeguard - Level I - 7180.1903 - \$8.25 - Seasonal - Retro to 7/7/11

Rachel Kuechle 14225

Recreation Attendant - 7310.1814 - Teen Club - Regular Part-time - \$8.00 - Retro to 6/7/11

Jennifer Zelasko

Recreation Attendant - 7310.1814 - Teen Club - Regular Part-time - \$7.50 - Retro to 6/27/11

Casey Hawley

RESULT:	ADOPTED [UNANIMOUS]
MOVER:	Richard Zydel, Councilmember
SECONDER:	James Rogowski, Councilmember
AYES:	Jaworowicz, Swiatek, Rogowski, Zydel, Markel, Kaznowski
ABSENT:	Mary Holtz



24. RESOLUTION 2011-425

Hiring/Termination of Part-Time/Seasonal Employees

Sponsored By: Councilmember Swiatek, Councilmember Kaznowski

BE IT RESOLVED, that the following individuals be and hereby are hired as **PART-TIME EMPLOYEES** in the departments listed, not to exceed nineteen (19) hours on a weekly basis, in compliance with Civil Service Laws and Regulations as well as the provisions of the Town's collective bargaining agreement between the Town of Cheektowaga and the Town of Cheektowaga Employees Association:

PERSONNEL DEPARTMENT Clerk (Temporary) \$8.00/hour effective 7/11/11
Megan Anne Latshaw, Cheektowaga, New York

POLICE DEPARTMENT Police Attendant \$14.00 effective 7/18/11
Rachel Lynn Kandefer, Cheektowaga, New York

POLICE DEPARTMENT Police Attendant \$16.10 effective 7/18/11
Douglas P. Szary, Cheektowaga, New York

TOWN CLERK'S OFFICE Clerk \$8.00/hour effective 7/11/11
Chelsea A. Dawe, Cheektowaga, New York

BE IT RESOLVED, that the following seasonal and/or part-time employees be and hereby are terminated as listed:

SEWER MAINTENANCE DEPARTMENT
Sean F. Ross effective 6/27/11

POLICE DEPARTMENT
Deborah L. Lopez effective 6/28/11

RESULT:	ADOPTED [UNANIMOUS]
MOVER:	Jeff Swiatek, Councilmember
SECONDER:	Stanley Kaznowski, Councilmember
AYES:	Jaworowicz, Swiatek, Rogowski, Zydel, Markel, Kaznowski
ABSENT:	Mary Holtz



25. RESOLUTION 2011-426

Appointment of Senior Assessment Clerk (Provisional) Office of the Town Assessor/Jill M. Oxley

Sponsored By: Councilmember Swiatek, Councilmember Jaworowicz

WHEREAS, a vacancy exists in the position of Senior Assessment Clerk in the Office of the Town Assessor; AND

WHEREAS, notice of said vacancy has been posted in accordance with the provisions of the Town's collective bargaining agreement with the Town of Cheektowaga Employees Association; AND

WHEREAS, said job title is in the competitive class of civil service; AND

WHEREAS, a current civil service list does not exist; AND

WHEREAS, Jill M. Oxley, currently employed as a Senior Clerk in the Office of the Town Assessor, bid on said vacancy and meets all the necessary qualifications for provisional appointment; NOW, THEREFORE, BE IT

RESOLVED, that Jill M. Oxley of Cheektowaga, New York, be and hereby is appointed to the provisional position of Senior Assessment Clerk in the Office of the Town Assessor in accordance with the terms and conditions of the Town's collective bargaining agreement with the Town of Cheektowaga Employees Association effective July 19, 2011.

RESULT:	ADOPTED [UNANIMOUS]
MOVER:	Jeff Swiatek, Councilmember
SECONDER:	Patricia Jaworowicz, Councilmember
AYES:	Jaworowicz, Swiatek, Rogowski, Zydel, Markel, Kaznowski
ABSENT:	Mary Holtz



26. RESOLUTION 2011-427

Travel Authorization Police Department/Sergeant Lawrence Bauer, Sergeant Thomas Allen, Police Officer Kurt Spieler and Police Officer Jay Ober

Sponsored By: Councilmember Jaworowicz, Councilmember Swiatek

WHEREAS, the Taser Instructor Recertification Course is being held August 12, 2011 in Warsaw, New York; AND

WHEREAS, Sergeant Lawrence Bauer, Sergeant Thomas Allen, Police Officer Kurt Spieler and Police Officer Jay Ober have requested authorization to attend said course; AND

WHEREAS, Police Chief David Zack has submitted a request for travel authorization along with the proper paperwork in a timely manner; AND

WHEREAS, the total cost to the Town shall not exceed \$934.91; AND

WHEREAS, these expenses have been budgeted by the Police Department; NOW, THEREFORE, BE IT

RESOLVED, that Sergeant Lawrence Bauer, Sergeant Thomas Allen, Police Officer Kurt Spieler and Police Officer Jay Ober be and hereby are authorized to attend the Taser Instructor Recertification Course being held August 12, 2011 in Warsaw, New York .

RESULT:	ADOPTED [UNANIMOUS]
MOVER:	Patricia Jaworowicz, Councilmember
SECONDER:	Jeff Swiatek, Councilmember
AYES:	Jaworowicz, Swiatek, Rogowski, Zydel, Markel, Kaznowski
ABSENT:	Mary Holtz

IV. Communications

A. Departmental Communications

1. Minutes: Cheektowaga Planning Board - June 9, 2011
2. 2011 Board of Assessment Review Hearing Results

B. General Communications

1. Notice of Claim: Kathi Freudenheim Vs. Town of Cheektowaga
2. Notice of Claim: State Farm Insurance for Dorothy D'Agostino Vs. Town of Cheektowaga

- 3. Notice of Claim: Darryl Williams; Sandra Hernandez Vs. Town of Cheektowaga
- 4. Summons: Deutsche Bank, NTC Vs. Susan Lopez, Town of Cheektowaga & Etal
Premises: 69 Bernice Drive

V. Comments

A. Supervisor's Comments

B. Councilmember's Comments

C. Public Comments

VI. Adjournment

Motion by Deputy Supervisor Swiatek; Seconded by Councilmember Rogowski to adjourn the meeting at 7:09 PM

Alice Magierski, Town Clerk

Table of Contents

Introduction 3

General Safety Rules 4

General Rules – Personal Safety 4

Fire & Explosion Prevention 5

Motor Vehicle Safety 6

Highway Rule 7

Accident Reporting 7

Protective Clothing 8

Housekeeping 8

Pumps and Sludge Removal 9

Laboratory 9

Recreation 9

Sanitation Department 10

Equipment – General 12

Department Head, Supervisor, and Foreman 12

Disciplinary Action 13

Penalties for Rule and Guideline Violations 14

Conclusion 14

Attachment: Safety Policy (RES-2011-406 : Adoption of Town Safety Manual)



Introduction

The following safety rules and guidelines have been established to insure the health and safety of the Town's employees and general public. They are applicable to all personnel. In addition, specific Departmental Safety Rules and Guidelines apply to all employees in that department.

The violation of certain safety rules, designated with an asterisk (*) will be considered "serious violations." In the event of a serious violation, the employee may be immediately suspended, and the procedure outlined in the governing collective bargaining agreement shall be implemented.

The violation of all other Safety Rules and Guidelines will result in progressively more serious discipline with termination of employment for repeated violations.

Please re-read the employee's responsibility for safety above and bear in mind these rules and guidelines have been established primarily for your protection. In general, injuries result from unsafe acts and unsafe conditions, both of which are often under the control of the injured employee.

Please strive to make your work place, and that of your co-workers, as accident and injury free as possible.



General Safety Rules

Applicable to All Personnel

1. Consumption of alcoholic beverages or the use of illegal drugs during work hours is strictly forbidden. Furthermore, reporting to work while under the influence of alcoholic beverages or drugs will not be tolerated.*
An employee may demand a breathalyzer test to demonstrate compliance with this rule.

Note: Employees taking prescription medications that cause drowsiness shall report the same to his/her supervisor upon reporting to work. It will be considered a serious incident should any employee be involved in any accident or incident causing injury to a person or property while on official duty under circumstances where the employee was taking a prescription medication that causes drowsiness and failed to report that to his/her supervisor.*

2. Firearms and weapons are not to be carried during work hours and are prohibited at work places.*
3. Immediately report all accidents causing injury to persons and/or damage to property to your supervisor. This includes damage to Town Property, as well.*
4. Employees are required to report, in writing, all dangerous hazards and equipment defects to your supervisor and safety committee upon discovery.*

General Rules – Personal Safety

1. Do not remove protective guards or alter safety devices on machinery or equipment.
2. Flashing lights, installed in the respective vehicle will be used when working on or near vehicular traffic areas.
3. With the exception of Sanitation workers, no person shall ride on or in the back of any vehicle cargo area or outside of vehicle.
4. With the exception of Sanitation workers, no person shall stand on back or side of a moving vehicle or on the cab top at any time.
5. Safety chains and protective guards will be provided by the town and shall be used by employees.
6. Retaining walls or proper shoring and ladders shall be provided where employees are assigned to work in excavations in excess of 5 feet in depth.
7. It is the responsibility of the respective supervisor of the worksite to test manhole for harmful gases before an employee enters a manhole. No employee will enter a manhole until the employee has received confirmation from the respective supervisor that the testing has been completed and there are no harmful gases
8. Blind shields for eye protection and portable blind shields will be provided for weld shops.
9. Building/garages will be properly ventilated with special provisions made in those garages where vehicles are left running.
10. All work areas will be properly illuminated.
11. Do not extend legs or arms over side of rear of vehicle.



12. Safety classes will be provided for employees during normal work hours. Where this is not practical, such classes will be provided during overtime.
13. All employees may receive tetanus and typhoid vaccinations at Town's expense, as required.
14. No raw sewage shall be transported in enclosed vans where employees are not separated from such storage area.
15. Sneakers and shorts may not be worn to perform daily assignments.
16. Safety goggles should be worn when and/or where appropriate.

Fire & Explosion Prevention

Rules

1. Do not smoke cigarettes, cigars, pipes, etc., within 25 feet of any Town building or within a town vehicle. Do not smoke or ignite matches, lighters, or torches near fuel tanks, or in the presence of fumes, flammable gases or substances.
2. Dust and powdered substances in the air are highly explosive. Employees shall not use flammable liquids near open flames or electrical panels or switches.
3. Smoke detectors shall comply with Town ordinance.
4. Sprinkler systems shall comply with Town ordinance.
5. Contents of containers/drums will be plainly marked.
6. "No Smoking" signs will be posted in restricted areas.
7. Fire extinguishers will be provided per applicable fire code.
8. Tires will be placed in cage and the lock rim checked while inflated after repair.
9. Cylinders, gas tanks and drums, etc., will be stored in safe, marked areas. In weld shops they will be placed upright and chained.
10. Fire extinguishers provided in a truck will be inspected routinely to ensure it is operational.
11. Operators assigned a truck with an extinguisher will be trained in the operation of the respective extinguisher.
12. Waste oil containers shall be covered at all times and marked as "Waste Oil."
13. Evacuation plans shall be conspicuously posted in all buildings.

Guidelines

1. Do not block exits, entrances, electrical panel boxes or switches.
2. Shut off vehicles while refueling.



Motor Vehicle Safety

Introduction

Motor vehicle safety is a combination of: driver training, vehicle inspection and maintenance; and most importantly, proper operation and use of vehicle by driver.

The vehicle operator is responsible for routine inspection and maintenance of the vehicle he/she operates for an effective safety program. A driver generally knows when a vehicle should not be driven.

The following rules and guidelines should be considered the minimum standards governing the operation of all Town of Cheektowaga motor vehicles.

Driver Qualifications and Training Rules

All current and prospective drivers must be licensed in New York State to drive the type of vehicle being used. A Class 1 or 3 license is required for trucks exceeding 18,000 pounds of MGW; a Class 1, 3, 4, or 5 license is satisfactory for passenger cars and trucks 18,000 pounds or less MGW. This rule applies even if the Town vehicle is driven only on Town premises. Persons with a driver's permit or Class 6 license may not drive Town vehicles without authorization.

Driver's Rules

For this section, a "driver" is defined as anyone operating a vehicle utilizing his or her CDL privileges.

1. Inspect vehicle and attachments in accordance with NY State CDL requirements.
2. Report any suspension or revocation of your driver's license immediately.
3. Place a tag on any defective vehicle or equipment that is not to be used until repaired or replaced.
4. Vehicles or equipment found to have steering, braking, or other serious defects during the period of operation shall not be driven, but shall be towed to the garage for repairs.
5. Operate all motor vehicles under posted or legal speed limits.
6. Operate all motor vehicles in a "defensive driving" manner and within the laws governing the use of the vehicle on the highway.
7. Report any information directly relating to your ability to safely operate a motor vehicle to your supervisor without delay. Also report any conviction of a moving traffic violation during work. Exhibit your ticket stub to your supervisor upon request.
8. Be sure any cargo, load or attachments on your vehicle are secure or fastened at all times.
9. In accordance with NY State Motor Vehicle Law, prior to backing-up, the driver is required to check behind the vehicle to be sure no pedestrians are crossing near the rear of the vehicle. Look for small children in particular. When possible, passenger should be outside vehicle directing driver. Get assistance when backing up when possible.
10. Rear doors on trucks must be closed or strapped when trucks are in motion.



11. If materials extend/project over rear of truck, doors must be tied and flag attached to end of materials.
12. Block wheels before jacking vehicle or equipment and be sure jacks are properly supported. This activity is normally performed by Central Garage staff.
13. Detour traffic around work site with cones or barricades.
14. The driver, at a minimum, should check the vehicle tires, lights, directional signals, and other safety equipment prior to leaving garage area.
15. Be sure all persons in work area, particularly those working under and/or behind vehicles are warned before moving vehicles or equipment in or near work area.

Driver's Guidelines

1. Do not follow closer than the distance required to stop your vehicle. Use the "two second rule" as a guide. The "two second rule" is a rule of thumb by which a driver may maintain a safe following distance at any speed. The rule is that the driver should stay at least two seconds behind any vehicle that is directly in front of the driver's vehicle. It is the equivalent of one vehicle length for every 5 mph of the current speed.
2. Keep the inside of vehicle cab clean and free of all litter.
3. Be alert to changing conditions (road conditions, weather, nearby schools, playgrounds, etc.)
4. Drive with particular care and caution; at all intersections (watch pedestrian crossings). Stop fully before making legal right turns at red signals.
 - a. When changing lanes, signal your plan ahead of time.
 - b. Yield to passing vehicles. Blind spots are not a valid excuse for an accident.
5. Garage areas will be posted with a speed limit. Please comply.
6. At expressway exits and entrance ramps, be sure speed is sufficiently reduced to avoid skidding on exit curves, particularly under slippery road conditions.
7. Prior to moving a vehicle in the garage honk horn twice to warn employees of oncoming vehicle(s).
8. If parking on incline, block wheels.
9. Tailgates must be raised and equipment load secured.

Highway Rule

Be sure the safety chain is attached to snow wing at all times when it is on the truck and truck is not in use.

Accident Reporting

The Cheektowaga Police Department will be notified in the event of a vehicular accident.

Prior to arrival of Police, the vehicle operator shall attempt to secure the license number of all vehicles involved in the accident as well as the names and addresses of all vehicle operators, passengers and witnesses.



Assist in any investigation or inquiry of an accident or damage occurring while you are in charge of a vehicle.

All accidents shall be reported immediately to your supervisor and employee designated to complete necessary accident/compensation forms.

Protective Clothing Rules

1. Wear clothing appropriate to your job. Protective clothing and/or equipment issued by the Town such as: hard hats, safety goggles, safety shoes, safety reflector clothing, gloves, ear protectors, safety harnesses, etc., for the performance of your duties, must be worn in designated work areas and required work situations. Replacements will be provided so long the previously issued items are not lost or misused.
2. Hard hats are to be worn when working below any work detail, when working on ladders, scaffolds, low ceilings, when entering manholes, sewers, and excavations or when working around excavation equipment, lawn maintenance equipment and grass cutting equipment.
 - a. Employees must wear hard hats when working behind trucks.
3. Safety goggles must be worn at all times when grinding, chiseling, performing tree work, chipping branches, grinding stumps, operating power equipment (i.e. saws, blow torches, etc.), welding and when using chemicals. Also to be worn where flying debris or dust is possible and when operating air compressors or jackhammers.
4. Safety shoes must be worn by all employees (excluding office personnel).
5. Safety reflector clothing must be worn when working on or near highways, at all times.
6. Gloves shall be worn when appropriate.
7. Ear protectors must be worn when using air compressors, jackhammers, tree/branch chipper, vac-alls.
8. Safety harness must be worn when entering a manhole.
9. Employees shall be provided with particle filter masks when working with chemicals, dust exposure, or paint.
10. Protective clothing and equipment must be used by welders. Leather gloves, vest (bib) and proper colored glasses will be worn.
11. No gloves will be worn when operating power saws or grinders.

Housekeeping - Applicable to Facilities Department Employees

Rules

1. Work areas will be kept orderly at all times.
2. Spills and loose debris will be cleaned up immediately.
3. Proper containers will be utilized for the disposal of waste, oil rags, and scrap.
4. Floors, steps, and hallways should be kept clean and free of obstructions.



Guidelines

1. Pick up and return tools and other items to proper place when finished and before leaving your work area.
2. "Wet Floor" signs must be used when mopping or waxing floors.
3. Be sure all lighting in your work area is maintained in proper operating condition.
4. Employees shall not place extension cords, cables, etc., across sidewalks, aisles, hallways, or other walkways. Use care in the placement of extension cords, cables, etc., to avoid tripping hazards.
5. Keep filing cabinet, desk, and other drawers closed.
6. No boxes, shelves or chairs are to be used to gain heights. Use ladders only.
7. No tools will be placed on ladder tops or steps.
8. When using electric tools and equipment, only grounded plugs and cords are permitted.
9. Keep all gas cylinders chained when not in use.

Pumps and Sludge Removal Guidelines

1. Clean all pumps from sludge, oil, and grease.
2. Check electrical equipment for bare wires.
3. Use ventilation provided.
4. Use gloves and eye protection.
5. Hoses that are used for cleaning pump areas are to be hung upon proper rack.

Pump Station Laboratory Guidelines

1. Do not handle chemicals with bare hands.
2. Check labels on bottles or containers for proper chemical to be used.
3. Use tongs or suitable tool when handling hot equipment.
4. Use suction bulb when working with pipette.
5. Check safety shower and emergency eye wash monthly.
6. Vent all fumes.
7. Use safety glasses at all times.
8. Do not use laboratory glassware for food or liquid to be used for lunch.
9. Wear laboratory coats that are provided.
10. "Water-Acid" – Always add the acid to the water, never the reverse.

Recreation Guidelines

1. Wear clothing suitable to the activity being pursued. Sneakers and other athletic footwear will be permitted as appropriate and bare feet will be permitted in the pool area, locker rooms, and showers.



2. Work shoes will be worn by employees excluding office personnel and those performing work described in No. 1.
3. Use appropriate equipment when engaged in athletic activities requiring such equipment.
4. Learn and follow Recreation Department rules and regulations.

Sanitation Department

Rules

1. Pick up on one side of the street. On all main highways, do not cross traffic lanes when picking up refuse, except where specific exception is made by Department Head.
2. Step away from falling containers.
3. Do not overfill hopper.
4. Do not dump while hopper is operating.
5. Stand to the side of the hopper, rather than behind it while it is piling.
6. Do not run behind truck where materials could fall or be ejected by packer.

Guidelines

1. Establish driver-rider coordination. Lifter should use hand signals to direct driver in backing.
2. Driver shall not move truck until both employees are securely placed on the steps or in the cab (except when proceeding or backing at the direction of a lifter).

Operation of Packer Controls Rules & Guidelines

Rules

1. Never try to dislodge, catch, or push back waste while the packer is operating. Keep away from hopper while it is in operation.
2. Lay boards and other long items in hopper so that they do not stick out or swing about when compacted.

Guidelines

1. Use left hand if controls are on right side; signal coworkers before operating packer.
2. Check positions of hands before closing tailgate.



Mounting and Dismounting

Guidelines

1. Mount and dismount only when truck has stopped and completed its backward lurching motion that occurs when stopping.
2. Watch where you place your feet.
3. Grasp handholds firmly. Always use two hands before mounting and until both feet are securely on the ground when dismounting.
4. Step up firmly and steadily when mounting, and dismount backwards (do not jump).
5. Inspect welds and braces supporting steps for cracks at start of each shift.

Riding In or On Truck – General

Rules – All Employees

1. No employee is to ride on step if the truck is moving beyond two blocks.
2. Do not ride on back of sanitation truck when the truck is backing-up.
3. When a sanitation truck is backing-up / going in reverse the assigned Laborers should be outside the vehicle and should be assisting the driver with the backing-up process.

Proper Lifting Techniques

Guidelines – All Employees

1. Rock containers to determine approximate weight before lifting.
2. Use two-man crews to lift overweight containers in a slow, steady lift in unison.
3. Always maintain a firm grip on containers and keep them close to the body.
4. Take a step while turning to dump, do not jerk or twist while lifting.
5. Know how much you can lift and use correct lifting techniques. Do not attempt to lift or carry anything by hand that is too heavy or bulky for one person to handle safely. Use the correct lifting device for the job.

Guidelines

1. Report all unsafe conditions to supervisor promptly.



2. Familiarize yourself with your duties and the tools and equipment used to perform those duties. Recognize the hazards of your job and equipment and do not take unnecessary risks.
3. No employee shall misuse, overload, or over extend any Town equipment or vehicle. Employees shall use correct tools and equipment for the work to be performed. Employees will check the condition of Town equipment of vehicles for safety prior to use.
4. The Town of Cheektowaga Police Department will investigate all accidents involving Town motor vehicles, maintain a record thereof, and assist department heads and supervisors in the furtherance of this program.
5. Supervisors or Department Heads will assist drivers in reporting all accidents, filing appropriate reports with the Town's insurer, the State of New York (when required) and the Coordinator of Employee Relations.

Each Department shall retain a copy of all accident reports and investigations with a copy included in the driver's file.

Equipment – General Guidelines

1. Always check ladders, steps, scaffolds, lifts, chain-falls, chains, chokers, cables, hooks, ropes, slings, hoists, jacks, grates, guards, etc., for wear or unsafe condition before use.
2. All machinery and power tools should be inspected for wear and hazardous conditions before use. Defective or hazardous equipment should be tagged and reported to your supervisor.
3. Do not operate power equipment and tools unless and until properly instructed in the safe use and handling of such equipment.

Department Head, Supervisor, and Foreman

Rules

All Department Heads, Supervisors and Foremen should:

1. Become fully acquainted with the Town Loss Control and Safety Program and the Safety Rules and Guidelines.
2. Always enforce the General Motor Vehicle and Department Safety Rules and Guidelines, and treat suspected violators impartially.
3. Be sure all employees, particularly new employees, are made aware of the Town Loss Control and Safety Program and are instructed in the safe manner of performing their work.
4. On the job training shall be provided to a respective employee prior to being assigned an activity or task.
5. Inspect and record the condition of all safety and fire fighting equipment at least monthly.
 - a. Arrange promptly for the repair of all defective or hazardous tools and equipment.
6. Develop ways to improve upon the General Motor Vehicle and Department Safety Rules and Guidelines and reduce the number of accidents and injuries.



7. Take a personal interest in the operation of your Department Safety Committee. Review their work and investigations of accident causes. Encourage the development of a positive attitude toward a safe place to work.
8. Take all reasonable steps to comply with our Insurer's recommendations and promptly advise the Insurer, the Coordinator of Employee Relations and the Town Safety Committee of compliance or compliance problems.

Guidelines

Whenever possible, rely on re-training and explanation of hazards, which the Safety Rules and Guidelines are designed to avoid. Do not, however, fail to impose appropriate discipline for repeated violations.

Disciplinary Action

The Town of Cheektowaga embraces the concept of progressive discipline. Progressive discipline is a process for dealing with job-related behavior that does not meet expected and communicated performance and/or conduct standards. The primary purpose for progressive discipline is to assist the employee to understand that a performance or conduct problem or opportunity for improvement exists. The process features increasingly formal efforts to provide feedback to the employee so he or she can correct the problem. The goal of progressive discipline is to improve employee performance and/or conduct.

The process of progressive discipline is not intended as a punishment for an employee, but to assist the employee to overcome performance and/or conduct problems and satisfy job expectations. Progressive discipline is most successful when it assists an individual to become an effectively performing member of the organization.

It is recognized that maintaining standards of safety is of utmost importance to the health and well-being of Town employees and residents. Each employee is responsible for taking the appropriate steps to maintain the standards of safety set forth in these rules and guidelines. Each instance involving a violation of these rules and guidelines will be handled individually. What discipline, if any, will be imposed will depend upon the facts and circumstances of each case.

Generally speaking, when determining the severity of any discipline there are certain essential factors that should be considered such as:

1. The nature and seriousness of the offense, and its relation to the employee's duties, position, and responsibilities, including whether the offense was intentional or technical or inadvertent, or was committed maliciously or for gain, or was frequently repeated;
2. The employee's job level and type of employment, including supervisory or fiduciary role, contacts with the public, and prominence of the position;
3. The employee's past disciplinary record;



4. The employee's past work record, including length of service, performance on the job, ability to get along with fellow workers, and dependability;
5. The effect of the offense upon the employee's ability to perform at a satisfactory level and its effect upon supervisors' confidence in the employee's work ability to perform assigned duties;
6. Consistency of the penalty with those imposed upon other employees for the same or similar offenses;
7. The notoriety of the offense or its impact upon the reputation of the Town;
9. The clarity with which the employee was on notice of any rules that were violated in committing the offense, or had been warned about the conduct in question;
10. The potential for the employee's rehabilitation;
11. Mitigating circumstances surrounding the offense such as unusual job tensions, personality problems, mental impairment, harassment, or bad faith, malice or provocation on the part of others involved in the matter; and
12. The adequacy and effectiveness of alternative sanctions to deter such conduct in the future by the employee or others.

Some of these factors may not be particularly pertinent in a particular case. However, it is critical to balance the relevant factors in each individual case and chose a reasonable penalty.

Typical steps in a progressive discipline system may include an oral reprimand, written reprimand, suspending the employee from work, demotion or discharge from employment.

Supervisors, Department Heads and employees must strive vigorously to maintain safety standards at all times and only through such efforts will the humane benefits of this program be accomplished.

Penalties for Rule and Guideline Violations

1. Serious Violations
 - a. Violations of a safety rule marked by an asterisk (*) in this section will be treated as a serious violation and that factor will be considered in assessing the disciplinary action to be taken against the violator.

Conclusion

The work of operating a Town encompasses many diverse operations which makes it impossible to prepare rules for each and every function or hazard. Thus, only a general set of rules can be



formulated. Common sense, consciousness of one's activity and interest in safety is a requirement of each employee.

Safety is to be the concern of all and no job should be started unless thought and effort is given to providing for safe operation.

Although safety starts with supervision, it is not enough for a supervisor and foreman to be conscious of performing safely on the job, but is the responsibility of each employee to be aware of his or her own safety and that of his/her fellow workers.

Accident prevention is a consideration from a humanitarian point of view and is an important obligation that we bear, and it must be remembered that each of us has a stake in safety.



Make	Model	Serial #	Asset #
Dell	Power Vault Tape Drive	97t0064507	n/a
Dell	Power Vault Tape 2205	2x1nw11	n/a
Dell	Power Edge 1850	f84g881	11943
Dell	Power Edge 850	2rg7p81	n/a
Dell	Power Edge 2650	631bx11	10741
Dell	Power Edge 2650	f48tm21	10718
Dell	Power Edge 1750	7f772p51	n/a
Dell	Power Edge 2650	g8snm21	10717
Dell	Power Edge 1750	hgpdf51	10715
Dell	Power Edge 2650	848tm21	n/a
Dell	Power Edge 2650	3mgf561	n/a
Dell	Power Edge 2650	1z5nm21	10719
Dell	Power Edge 2650	dpcft31	10745
Dell	Power Edge 1750	c5md531	n/a
Dell	Power Edge 850	6rg7p81	n/a
Sphereon	4500	t2016433	n/a
Sphereon	4500	t2015977	n/a
Sphereon	4500	t2010832	n/a
Sphereon	4500	t2015467	n/a
Dell	Laser Printer 1700	cn0n4386487304bg4hhv	n/a
HP	Laser Printer 1012	cnfb553171	n/a



Town of Cheektowaga

Regular Meeting

~ Minutes ~

3301 Broadway
Cheektowaga, NY 14227

<http://www.town.cheektowaga.ny.us>

Alice Magierski
716-686-3400

Monday, August 1, 2011

6:45 PM

Council Chambers

I. Call to Order

6:45 PM Meeting called to order on August 1, 2011 at Council Chambers, 3301 Broadway St, Cheektowaga, NY.

Attendee Name	Organization	Title	Status	Arrived
Mary Holtz	Town of Cheektowaga	Supervisor	Present	
Patricia Jaworowicz	Town of Cheektowaga	Councilmember	Present	
Jeff Swiatek	Town of Cheektowaga	Councilmember	Present	
James Rogowski	Town of Cheektowaga	Councilmember	Present	
Richard Zydel	Town of Cheektowaga	Councilmember	Present	
Charles Markel	Town of Cheektowaga	Councilmember	Present	
Stanley Kaznowski	Town of Cheektowaga	Councilmember	Present	

2. Additional Attendees

Thomas Adamczak, Supervising Building and Plumbing Inspector
John Glascott, Captain, Cheektowaga Police
Brian Krause, Director of Finance and Administration
John Marriott, Planning Board Chairman
William Pugh, Town Engineer
Anthony Romano, Coordinator of Employee Relations
Kevin Schenk, Town Attorney
Mark Wegner, Highway Superintendent

II. Public Comment Period

III. Resolutions



1. RESOLUTION 2011-428

Transfer of Funds

Sponsored By: Supervisor Holtz, Councilmember Swiatek

BE IT RESOLVED, that the following transfer is hereby approved and made a part hereof;

GENERAL FUND

FROM: 100.1910.2680 Insurance Recoveries \$ 5,395.48

TO: 100.1640.4447 Collision Repairs \$ 5,395.48

RESULT: ADOPTED [UNANIMOUS]

MOVER: Mary Holtz, Supervisor

SECONDER: Jeff Swiatek, Councilmember

AYES: Holtz, Jaworowicz, Swiatek, Rogowski, Zydel, Markel, Kaznowski



2. RESOLUTION 2011-429

Warrant

Sponsored By: Supervisor Holtz, Councilmember Swiatek

BE IT RESOLVED, that the following Vouchers & Warrants submitted to the Town of Cheektowaga prior to July 29, 2011 are hereby approved and made a part hereof;

GENERAL FUND	\$ 1,152,658.97
RISK RETENTION FUND	24,015.96
DEBT SERVICE FUND	7,101.40
HUD HOUSING REHABILITATION FUND	12,523.00
SPECIAL DISTRICTS FUND	450,962.46
HIGHWAY FUND	276,818.40
CAPITAL FUND	1,011,199.76
TRUST & AGENCY FUND	24,418.65
HUD CDBG FUND	858.59
PART TOWN FUND	44,289.93
NYS AFFORDABLE HOUSING	11,203.00
	<u>\$ 3,016,050.12</u>

RESULT:	ADOPTED [UNANIMOUS]
MOVER:	Mary Holtz, Supervisor
SECONDER:	Jeff Swiatek, Councilmember
AYES:	Holtz, Jaworowicz, Swiatek, Rogowski, Zydel, Markel, Kaznowski



3. RESOLUTION 2011-430

Notice to Bidders - Demolition of 89 Gardenvale Drive

Sponsored By: Councilmember Markel, Councilmember Kaznowski

WHEREAS, it is in order that bids be advertised for the demolition with asbestos abatement of a structure located at 89 Gardenvale Drive in the Town of Cheektowaga, and

WHEREAS, specifications for same have been prepared by Nussbaumer & Clarke, Inc., NOW, THEREFORE, BE IT

RESOLVED, that the Town Clerk be and hereby is directed to publish a Notice to Bidders in connection with the demolition of 89 Gardenvale Drive, said notice to be published in the CHEEKTOWAGA BEE, and BE IT FURTHER

RESOLVED, that sealed bids will be received and opened by the Town Clerk at a public bid opening to be held in the Council Chambers at the Cheektowaga Town Hall on Wednesday, August 10, 2011 at 11:00 A.M.

NOTICE TO BIDDERS

Sealed proposals will be received by the Town Clerk of the Town of Cheektowaga on Wednesday, August 10, 2011, at 11:00 A.M. at the Town Hall, 3301 Broadway, Cheektowaga, New York, for the demolition with asbestos abatement of 89 Gardenvale Drive in the Town of Cheektowaga.

Information for bidders and specifications may be obtained from the Town Clerk at her office in said Town.

The Town Board reserves the right to consider informal any bid not prepared and submitted in accordance with the provisions of the specification and contract documents, and may waive any informalities, make an award to other than the low bidder, or reject any or all bids should it be in the best interest of the Town.

BY ORDER OF THE TOWN BOARD OF THE TOWN OF CHEEKTOWAGA, ERIE COUNTY, NEW YORK.

Dated: August 1, 2011

Alice Magierski
Town Clerk

RESULT:	ADOPTED [UNANIMOUS]
MOVER:	Charles Markel, Councilmember
SECONDER:	Stanley Kaznowski, Councilmember
AYES:	Holtz, Jaworowicz, Swiatek, Rogowski, Zydel, Markel, Kaznowski



4. RESOLUTION 2011-431

Special Events - Combat Sports Softball

Sponsored By: Councilmember Rogowski, Councilmember Zydel

WHEREAS, by resolution dated May 1, 1995, this Town Board adopted a Special Events policy, which requires anyone wishing to hold a special event in the Town to file an application and supporting documentation, fees, etc. to the Town Clerk prior to the special event, and

WHEREAS, the Combat Sports Softball has made application to hold its "Softball Tournament" in Stiglmeier Park on Saturday, August 27, 2011, (rain date: Sunday, August 28th except Diamond #3) and

WHEREAS, this Board has reviewed the aforementioned application, which application has been approved by the Police Department and the Department of Parks, Recreation & Youth Services, and has no objection to same, and

WHEREAS, due to the nature of the event, this Town Board hereby waives the following requirements:

1. Submittal of plan for sanitary facilities;
2. Submittal of site plan;
3. Submittal of Security Plan; submittal of Fire Prevention/Emergency Services Plan;

NOW, THEREFORE, BE IT

RESOLVED, that this Town Board hereby approves the aforementioned application of the Combat Sports Softball for the aforementioned "Softball Tourney" to be held in Stiglmeier Park on Saturday, August 27, 2011 (rain date: Sunday August 28th except Diamond #3).

RESULT:	ADOPTED [UNANIMOUS]
MOVER:	James Rogowski, Councilmember
SECONDER:	Richard Zydel, Councilmember
AYES:	Holtz, Jaworowicz, Swiatek, Rogowski, Zydel, Markel, Kaznowski



5. RESOLUTION 2011-432

2011 Family Support Contract

Sponsored By: Councilmember Zydel, Councilmember Rogowski

BE IT RESOLVED that subject to approval by the Town Attorney the Supervisor be and hereby is authorized to execute the 2011 Family Support Contract (C 023360 #1) in the amount of \$28,886.00, on behalf of the Department of Youth & Recreational Services and the New York State Office of Mental Retardation and Developmental Disabilities.

RESULT:	ADOPTED [UNANIMOUS]
MOVER:	Richard Zydel, Councilmember
SECONDER:	James Rogowski, Councilmember
AYES:	Holtz, Jaworowicz, Swiatek, Rogowski, Zydel, Markel, Kaznowski



6. RESOLUTION 2011-433

Authorize Supervisor to Execute Agreements with School Districts Concerning Cameras in the Schools

Sponsored By: Councilmember Rogowski, Councilmember Jaworowicz

WHEREAS, Cheektowaga Central School District, Cheektowaga Maryvale Union Free School District, Cheektowaga Sloan Union Free School District, Cleveland Hill Union Free School District and Harkness Career & Technical Center (hereinafter collectively referred to as "School Districts") operate public schools located in the Town of Cheektowaga, and

WHEREAS, surveillance cameras are and/or will be installed in the School Districts' buildings to monitor the hallways, etc., and

WHEREAS, the School Districts desire to have the Town, through its Police Department, monitor the aforesaid surveillance camera video stream for the safety of the school children, teachers, etc., and

WHEREAS, video streams from the aforesaid cameras will be relayed to the Town Police Department Dispatch Center (hereinafter referred to as "Dispatch Center") via microwave links from Erie BOCES building located at 355 Harlem Road, West Seneca (hereinafter referred to as the "Erie BOCES building"), and

WHEREAS, in order for this microwave system/surveillance camera video streams to become operational, it is necessary for certain equipment (hereinafter referred to as "equipment") to be installed at Erie BOCES building and the Dispatch Center, and

WHEREAS, the Town has agreed to purchase this equipment, and the participating School Districts have agreed to reimburse the Town for all costs associated with the purchase, installation and maintenance of such equipment, and

WHEREAS, the cost of the equipment and installer is estimated at \$30,872.00, and the cost of maintenance will be billed at \$95.00 per hour (for two (2) workers); and

WHEREAS, an agreement between the Town and the School Districts is authorized by Article 13 of the General Municipal Law of the State of New York, and

WHEREAS, the Town Attorney has prepared agreements between the Town and the School Districts for this purpose, NOW, THEREFORE, BE IT

RESOLVED, that the Supervisor be and hereby is authorized and directed to execute agreements with the School Districts for the above stated purpose.

RESULT:	ADOPTED [UNANIMOUS]
MOVER:	James Rogowski, Councilmember
SECONDER:	Patricia Jaworowicz, Councilmember
AYES:	Holtz, Jaworowicz, Swiatek, Rogowski, Zydel, Markel, Kaznowski



7. RESOLUTION 2011-434

Authorize Supervisor to Execute Lease with Heritage Centers

Sponsored By: Supervisor Holtz, Councilmember Jaworowicz

WHEREAS, NYSARC, Inc. Erie County Chapter, d/b/a Heritage Centers (hereinafter referred to as "Heritage Centers"), owns property located at 777 Maryvale Drive in the Town of Cheektowaga, and

WHEREAS, the Town of Cheektowaga Police Department has requested that Heritage Centers allow it to use a portion of the parking lot located between 777 Maryvale Drive and 735 Maryvale Drive to the west of the grass median, and

WHEREAS, Heritage Centers has agreed to said request at no cost to the Town provided that the Town enters into a Lease Agreement with it and provides it with liability coverage for the use of said property, and

WHEREAS, this Board is agreeable to the terms of said Lease, NOW, THEREFORE, BE IT

RESOLVED, that the Supervisor be and hereby is authorized and directed to enter into a Lease Agreement with Heritage Centers for the aforementioned use of the parking lot, subject to the review and approval of same by the Town Attorney, and BE IT FURTHER

RESOLVED, that this Town Board hereby agrees that the Town will indemnify Heritage Centers through its self insured liability program.

RESULT:	ADOPTED [UNANIMOUS]
MOVER:	Mary Holtz, Supervisor
SECONDER:	Patricia Jaworowicz, Councilmember
AYES:	Holtz, Jaworowicz, Swiatek, Rogowski, Zydel, Markel, Kaznowski



8. RESOLUTION 2011-435

Removal of Unsafe Tree/95 Huth Road

Sponsored By: Councilmember Markel, Councilmember Kaznowski

WHEREAS, Town of Cheektowaga Law for the Administration and Enforcement of the Codes of New York State; and the Property Maintenance Code of New York State require that all vacant structures and premises shall be maintained in clean, safe, secure and sanitary conditions so as not to cause a blighting problem or adversely affect the public health or safety and all nuisances abated, AND

WHEREAS, the Town of Cheektowaga has received notification of an unsafe structure and premises located at 95 Huth Road, Cheektowaga, New York SBL# 91.06-18-1 that is a danger to the safety of others, and records kept by the Assessors Office identify Marjorie Rickert, 95 Huth Road, Cheektowaga, New York 14225, as the owner AND

WHEREAS, an inspection of such premises was conducted at 95 Huth Road, by the Housing and Neighborhood Preservation Office, AND

WHEREAS, such inspection found the premises to be deteriorated, vacant, a hazard, and a danger to the safety and well being of others, AND

WHEREAS, the Town of Cheektowaga Housing and Neighborhood Preservation Office properly notified the property owner in accordance with the Town of Cheektowaga Law for the Administration and Enforcement of the Codes of New York State, and the owner failed to take actions to safeguard the premises, AND

WHEREAS, these conditions require the Town of Cheektowaga Housing and Neighborhood Preservation Office to take immediate steps to safeguard the premises to protect the health and safety of others and abate all nuisances, NOW, THEREFORE BE IT

RESOLVED, that pursuant to Section 70-7A.(5) and Section 70-8 of the Town of Cheektowaga Law for the Administration and Enforcement of the Codes of New York State that the vacant structure premises be safeguarded and all nuisances abated; and all costs incurred be assessed against the property hereinbefore described

RESULT:	ADOPTED [UNANIMOUS]
MOVER:	Charles Markel, Councilmember
SECONDER:	Stanley Kaznowski, Councilmember
AYES:	Holtz, Jaworowicz, Swiatek, Rogowski, Zydel, Markel, Kaznowski



9. RESOLUTION 2011-436

Minor Demolition-Shed/1465 Cleveland Drive

Sponsored By: Councilmember Markel, Councilmember Kaznowski

WHEREAS, Town of Cheektowaga Law for the Administration and Enforcement of the Codes of New York State; and the Property Maintenance Code of New York State require that all vacant structures and premises shall be maintained in clean, safe, secure and sanitary conditions so as not to cause a blighting problem or adversely affect the public health or safety and all nuisances abated, AND

WHEREAS, the Town of Cheektowaga has received notification of an unsafe structure and premises located at 1465 Cleveland Drive, Cheektowaga, New York SBL# 92.05-5-6 that is a danger to the safety of others, and records kept by the Assessors Office identify Floyd J. Lewis, C/O Financial Freedom, PO Box 4046, Kalamazoo, MI 49003, as the owner AND

WHEREAS, an inspection of such premises was conducted at 1465 Cleveland Drive, by the Housing and Neighborhood Preservation Office, AND

WHEREAS, such inspection found the premises to be deteriorated, vacant, a hazard, and a danger to the safety and well being of others, AND

WHEREAS, the Town of Cheektowaga Housing and Neighborhood Preservation Office properly notified the property owner in accordance with the Town of Cheektowaga Law for the Administration and Enforcement of the Codes of New York State, and the owner failed to take actions to safeguard the premises, AND

WHEREAS, these conditions require the Town of Cheektowaga Housing and Neighborhood Preservation Office to take immediate steps to safeguard the premises to protect the health and safety of others and abate all nuisances, NOW, THEREFORE BE IT

RESOLVED, that pursuant to Section 70-7A.(5) and Section 70-8 of the Town of Cheektowaga Law for the Administration and Enforcement of the Codes of New York State that the vacant structure premises be safeguarded and all nuisances abated; and all costs incurred be assessed against the property hereinbefore described

RESULT:	ADOPTED [UNANIMOUS]
MOVER:	Charles Markel, Councilmember
SECONDER:	Stanley Kaznowski, Councilmember
AYES:	Holtz, Jaworowicz, Swiatek, Rogowski, Zydel, Markel, Kaznowski



10. RESOLUTION 2011-437

Unsafe-Unsecured/53 Euclid Avenue

Sponsored By: Councilmember Markel, Councilmember Kaznowski

WHEREAS, Town of Cheektowaga Law for the Administration and Enforcement of the Codes of New York State; and the Property Maintenance Code of New York State require that all vacant structures and premises shall be maintained in clean, safe, secure and sanitary conditions so as not to cause a blighting problem or adversely affect the public health or safety and all nuisances abated, AND

WHEREAS, the Town of Cheektowaga has received notification of an unsafe structure and premises located at 53 Euclid Avenue, Cheektowaga, New York SBL# 101.60-3-38 that is a danger to the safety of others, and records kept by the Assessors Office identify Kysha A. Shaw, Sylus LLC, 295 Greenwich Street, Suite 188, New York City, New York 10007 as the owner AND

WHEREAS, an inspection of such premises was conducted at 53 Euclid Avenue, by the Housing and Neighborhood Preservation Office, AND

WHEREAS, such inspection found the premises to be deteriorated, vacant, a hazard, and a danger to the safety and well being of others, AND

WHEREAS, the Town of Cheektowaga Housing and Neighborhood Preservation Office properly notified the property owner in accordance with the Town of Cheektowaga Law for the Administration and Enforcement of the Codes of New York State, and the owner failed to take actions to safeguard the premises, AND

WHEREAS, these conditions require the Town of Cheektowaga Housing and Neighborhood Preservation Office to take immediate steps to safeguard the premises to protect the health and safety of others and abate all nuisances, NOW, THEREFORE BE IT

RESOLVED, that pursuant to Section 70-7A.(5) and Section 70-8 of the Town of Cheektowaga Law for the Administration and Enforcement of the Codes of New York State that the vacant structure premises be safeguarded and all nuisances abated; and all costs incurred be assessed against the property hereinbefore described

RESULT:	ADOPTED [UNANIMOUS]
MOVER:	Charles Markel, Councilmember
SECONDER:	Stanley Kaznowski, Councilmember
AYES:	Holtz, Jaworowicz, Swiatek, Rogowski, Zydel, Markel, Kaznowski



11. RESOLUTION 2011-438

Memorialize State Legislature to Enact Domestic Abuse Legislation

Sponsored By: Councilmember Markel, Supervisor Holtz

WHEREAS, domestic violence by spouses and domestic partners is a serious crime and has been increasing throughout the country, and

WHEREAS, domestic violence disrupts families and causes severe emotional trauma and physical injuries to its victims, and

WHEREAS, the Penal Law of the State of New York presently does not list any crime of domestic abuse, but only contains general provisions relating to assault not limited to persons in domestic relations, and

WHEREAS, something needs to be done to control this epidemic of violence in New York State, and

WHEREAS, New York State Assemblyman Dennis H. Gabryszak has sponsored a bill (A03458) which would create the crime of domestic abuse in the first, second and third degrees; and create a judicial diversion program for domestic abuse defendants, and

WHEREAS, this bill would make domestic abuse a misdemeanor or felony depending on the severity of the abuse, and mandate participation in a program designed to end abusive behavior of defendants found guilty of domestic abuse, and

WHEREAS, this Board feels that this legislation is needed to reduce incidents of domestic violence and should be enacted post haste, NOW, THEREFORE, BE IT

RESOLVED, that this Town Board hereby memorializes the State Legislature to enact Assembly Bill No. A03458 as soon as possible, and BE IT FURTHER

RESOLVED, that the Town Clerk be and hereby is directed to forward certified copies of this resolution to all New York State Assembly Members, State Senators, and Governor Andrew Cuomo.

RESULT:	ADOPTED [UNANIMOUS]
MOVER:	Charles Markel, Councilmember
SECONDER:	Mary Holtz, Supervisor
AYES:	Holtz, Jaworowicz, Swiatek, Rogowski, Zydel, Markel, Kaznowski



12. RESOLUTION 2011-439

Youth & Recreation Transfers

Sponsored By: Councilmember Zydel, Councilmember Rogowski

BE IT RESOLVED that the individuals listed below be and hereby are hired and/or transferred, as indicated, in the Department of Youth & Recreational Services, effective as indicated:

Recreation Aide to Recreation Attendant - 7310.1810 - \$7.50 - Regular Part-time - Retro to 7/5/11

Martin Acevedo
Kelly Mayer

RESULT:	ADOPTED [UNANIMOUS]
MOVER:	Richard Zydel, Councilmember
SECONDER:	James Rogowski, Councilmember
AYES:	Holtz, Jaworowicz, Swiatek, Rogowski, Zydel, Markel, Kaznowski



13. RESOLUTION 2011-440

Appointment of General Mechanic (Non-Competitive/Permanent) Peter M. Kreavy, Jr./Facilities Department

Sponsored By: Councilmember Swiatek, Supervisor Holtz

WHEREAS, a vacancy exists in the position of General Mechanic in the Facilities Department (Building Maintenance Division); AND

WHEREAS, notice of such vacancy has been posted in accordance with the provisions of the Town's collective bargaining agreement with the Town of Cheektowaga Employees Association; AND

WHEREAS, no bargaining unit member bid on said vacancy; AND

WHEREAS, Peter M. Kreavy, Jr., currently employed as a temporary Maintenance Worker in the Facilities Department, applied for said vacancy and meets the qualifications for appointment; NOW, THEREFORE, BE IT

RESOLVED, that Peter M. Kreavy, Jr. of Cheektowaga, New York, be and hereby is appointed to the position of General Mechanic in the Facilities Department (Building Maintenance Division), pursuant to the terms and conditions as set forth in the collective bargaining agreement between the Town of Cheektowaga and the Town of Cheektowaga Employees Association effective August 2, 2011.

RESULT:	ADOPTED [UNANIMOUS]
MOVER:	Jeff Swiatek, Councilmember
SECONDER:	Mary Holtz, Supervisor
AYES:	Holtz, Jaworowicz, Swiatek, Rogowski, Zydel, Markel, Kaznowski



14. RESOLUTION 2011-441

Appointment of Building Maintenance Worker (Non-Competitive/Permanent) Marc J. Meyers/Sewer Maintenance Department

Sponsored By: Councilmember Swiatek, Supervisor Holtz

WHEREAS, a vacancy exists in the title of Building Maintenance Worker in the Sewer Maintenance Department; AND

WHEREAS, the Town of Cheektowaga Employees Association has agreed to waive the posting of said vacancy; AND

WHEREAS, the Sewer Maintenance Department was canvassed internally in accordance with an agreement with the Town of Cheektowaga Employees Association; AND

WHEREAS, Marc J. Meyers, currently employed as a Motor Equipment Operator - A in the Sewer Maintenance Department, bid on said vacancy and meets the qualifications for appointment; NOW, THEREFORE, BE IT

RESOLVED, that Marc J. Meyers of West Seneca, New York, be and hereby is appointed to the position of Building Maintenance Worker in the Sewer Maintenance Department in accordance with the terms and conditions of the Town's collective bargaining agreement with the Town of Cheektowaga Employees Association effective August 2, 2011.

RESULT:	ADOPTED [UNANIMOUS]
MOVER:	Jeff Swiatek, Councilmember
SECONDER:	Mary Holtz, Supervisor
AYES:	Holtz, Jaworowicz, Swiatek, Rogowski, Zydel, Markel, Kaznowski

**15. RESOLUTION 2011-442****Appointment of Motor Equipment Operator-A (Non-Competitive/Permanent) Peter J. Dudek/Sewer Maintenance Department**

Sponsored By: Councilmember Swiatek, Supervisor Holtz

WHEREAS, a vacancy exists in the title of Motor Equipment Operator - A in the Sewer Maintenance Department; AND

WHEREAS, the Town of Cheektowaga Employees Association has agreed to waive the posting of said vacancy; AND

WHEREAS, the Sewer Maintenance Department was canvassed internally in accordance with an agreement with the Town of Cheektowaga Employees Association; AND

WHEREAS, Peter J. Dudek, currently employed as a Senior Sewer Maintenance Worker in the Sewer Maintenance Department bid on said vacancy and meets the qualifications for appointment; NOW, THEREFORE, BE IT

RESOLVED, that Peter J. Dudek of Cheektowaga, New York, be and hereby is appointed to the position of Motor Equipment Operator - A in the Sewer Maintenance Department in accordance with the terms and conditions of the Town's collective bargaining agreement with the Town of Cheektowaga Employees Association effective August 2, 2011.

RESULT:	ADOPTED [UNANIMOUS]
MOVER:	Jeff Swiatek, Councilmember
SECONDER:	Mary Holtz, Supervisor
AYES:	Holtz, Jaworowicz, Swiatek, Rogowski, Zydel, Markel, Kaznowski



16. RESOLUTION 2011-443

Appointment of Sewer Maintenance Worker (Non-Competitive/Permanent) Lisa M. Sprada/Sewer Maintenance Department

Sponsored By: Councilmember Swiatek, Supervisor Holtz

WHEREAS, a vacancy exists in the title of Sewer Maintenance Worker in the Sewer Maintenance Department; AND

WHEREAS, notice of said vacancy has been posted in accordance with the provisions of the Town's collective bargaining agreement with the Town of Cheektowaga Employees Association; AND

WHEREAS, Lisa M. Sprada, currently employed as a Clerk Typist in the Sewer Maintenance Department, bid on said vacancy and meets the qualifications for appointment; NOW, THEREFORE, BE IT

RESOLVED, that Lisa M. Sprada of Cheektowaga, New York, be and hereby is appointed to the position of Sewer Maintenance Worker in the Sewer Maintenance Department in accordance with the terms and conditions of the Town's collective bargaining agreement with the Town of Cheektowaga Employees Association effective August 2, 2011.

RESULT:	ADOPTED [UNANIMOUS]
MOVER:	Jeff Swiatek, Councilmember
SECONDER:	Mary Holtz, Supervisor
AYES:	Holtz, Jaworowicz, Swiatek, Rogowski, Zydel, Markel, Kaznowski



17. RESOLUTION 2011-444

Appointment of Motor Equipment Operator-B (Non-Competitive/Permanent) Scott R. Fullington/Sanitation Department

Sponsored By: Councilmember Swiatek, Supervisor Holtz

WHEREAS, a vacancy exists in the title of Motor Equipment Operator - B in the Sanitation Department; AND

WHEREAS, notice of such vacancy has been posted in accordance with the provisions of the Town's collective bargaining agreement with the Town of Cheektowaga Employees Association; AND

WHEREAS, Scott R. Fullington, currently employed as a Park Maintenance Worker I in the Facilities Department, bid on said vacancy and meets the qualifications for appointment; NOW, THEREFORE, BE IT

RESOLVED, that Scott R. Fullington of Cheektowaga, New York, be and hereby is appointed to the position of Motor Equipment Operator - B in the Sanitation Department in accordance with the terms and conditions of the Town's collective bargaining agreement with the Town of Cheektowaga Employees Association effective August 23, 2011.

RESULT:	ADOPTED [UNANIMOUS]
MOVER:	Jeff Swiatek, Councilmember
SECONDER:	Mary Holtz, Supervisor
AYES:	Holtz, Jaworowicz, Swiatek, Rogowski, Zydel, Markel, Kaznowski



18. RESOLUTION 2011-445

Appointment of Laborer (Labor/Permanent) James J. Dalka/Sanitation Department

Sponsored By: Councilmember Swiatek, Supervisor Holtz

WHEREAS, a vacancy exists in the title of Laborer in the Sanitation Department; AND

WHEREAS, notice of such vacancy has been posted in accordance with the provisions of the Town's collective bargaining agreement with the Town of Cheektowaga Employees Association; AND

WHEREAS, James J. Dalka, currently employed as a Laborer in the Highway Department, bid on said vacancy and meets the qualifications for appointment; NOW, THEREFORE, BE IT

RESOLVED, that James J. Dalka of Depew, New York, be and hereby is appointed to the position of Laborer in the Sanitation Department in accordance with the terms and conditions of the Town's collective bargaining agreement with the Town of Cheektowaga Employees Association effective August 2, 2011.

RESULT:	ADOPTED [UNANIMOUS]
MOVER:	Jeff Swiatek, Councilmember
SECONDER:	Mary Holtz, Supervisor
AYES:	Holtz, Jaworowicz, Swiatek, Rogowski, Zydel, Markel, Kaznowski



19. RESOLUTION 2011-446

Travel Authorization Police Department/Sergeant Thomas Allen

Sponsored By: Councilmember Jaworowicz, Councilmember Swiatek

WHEREAS, the "NTOA Crisis Negotiators Conference" is being held October 11 through October 14, 2011 in Tempe, Arizona; AND

WHEREAS, Sergeant Thomas Allen has requested authorization to attend said conference; AND

WHEREAS, Police Chief David Zack has submitted a request for travel authorization along with the proper paperwork in a timely manner; AND

WHEREAS, the total cost to the Town shall not exceed \$703.42; AND

WHEREAS, these expenses have been budgeted by the Police Department; NOW, THEREFORE, BE IT

RESOLVED, that Sergeant Thomas Allen be and hereby is authorized to attend the "NTOA Crisis Negotiators Conference" being held October 11 through October 14, 2011 in Tempe, Arizona.

RESULT:	ADOPTED [UNANIMOUS]
MOVER:	Patricia Jaworowicz, Councilmember
SECONDER:	Jeff Swiatek, Councilmember
AYES:	Holtz, Jaworowicz, Swiatek, Rogowski, Zydel, Markel, Kaznowski

IV. Communications

A. Departmental Communications

1. Supervisor's Statement of Funds - June 2011
2. Building Permit List - July 2011
3. Minutes: Cheektowaga Traffic Safety Commission - June 21, 2011
4. Minutes: Cheektowaga Conservation Advisory Council - July 7, 2011
5. Minutes: Town Environmental Advisory Committee - July 13, 2011
6. Minutes: Cheektowaga Planning Board - July 14, 2011
7. Town of Cheektowaga Emergency Services - Quarterly Report for April to June 2011

B. General Communications

1. Notice of Claim: Kevin Bieman Vs. Town of Cheektowaga
2. Notice of Claim: Kayla Gallagher Vs. Town of Cheektowaga
3. Notice of Claim: GEICO as Subrogee for Christopher Bard Vs. Town of Cheektowaga
4. Notice of Claim: James D. Haas Vs. Town of Cheektowaga
5. Notice of Claim: Charles J Rauscher Vs. Town of Cheektowaga
6. Notice of Claim: Alfred R. Ruda Vs. Town of Cheektowaga
7. Notice of Claim: Donald R. White II Vs. Town of Cheektowaga
8. Notice of Petition: Lorenz & Sons Vs. Assessor of the Town of Cheektowaga and the Board of Assessment Review
9. Notice of Petition: Noco Energy Corp. Vs. Assessor of the Town of Cheektowaga and the Board of Assessment Review
10. Notice of Petition: Noco Energy Corp. Vs. Assessor of the Town of Cheektowaga and the Board of Assessment Review
11. Notice of Petition: Costanzo's Realty Inc. Vs. Assessor of the Town of Cheektowaga and the Board of Assessment Review
12. Notice of Petition: Harlem Buffalo, LLC Vs. Assessor of the Town of Cheektowaga and the Board of Assessment Review
13. Notice of Petition: CM Scrivner, LLC Vs. Assessor of the Town of Cheektowaga and the Board of Assessment Review
14. Notice of Petition: 84 Aero LLC Vs. Assessor of the Town of Cheektowaga and the Board of Assessment Review
15. Notice of Petition: 1885 Harlem LLC Vs. Assessor of the Town of Cheektowaga and the Board of Assessment Review
16. Notice of Petition: Atlas Self Storage Vs. Assessor of the Town of Cheektowaga and the Board of Assessment Review
17. Notice of Petition: Alex G. Schmidt Vs. Assessor of the Town of Cheektowaga and the Board of Assessment Review
18. Notice of Petition: Acquest Village Plaza, LLC Vs. Assessor of the Town of Cheektowaga and the Board of Assessment Review
19. Notice of Petition: McDonald's Vs. Assessor of the Town of Cheektowaga and the Board of Assessment Review
20. Notice of Petition: Gold Seal Equity Partnership Vs. Assessor of the Town of Cheektowaga and the Board of Assessment Review

21. Notice of Petition: Lancer Court Apartments Vs. Assessor of the Town of Cheektowaga and the Board of Assessment Review
22. Notice of Petition: Garden Village Apartments, LP Vs. Assessor of the Town of Cheektowaga and the Board of Assessment Review
23. Notice of Petition: Williamstowne Apartments, LP Vs. Assessor of the Town of Cheektowaga and the Board of Assessment Review
24. Notice of Petition: WP Walden Associates, LP Vs. Assessor of the Town of Cheektowaga and the Board of Assessment Review
25. Notice of Petition: Walden Consumer Square, LLC Vs. Assessor of the Town of Cheektowaga and the Board of Assessment Review
26. Notice of Petition: BG Thruway LLC Vs. Assessor of the Town of Cheektowaga and the Board of Assessment Review
27. Notice of Petition: DDR MDT Union Consumer Square, LLC Vs. Assessor of the Town of Cheektowaga and the Board of Assessment Review
28. Notice of Petition: DDR MDT Union Consumer Square, LLC Vs. Assessor of the Town of Cheektowaga and the Board of Assessment Review
29. Notice of Petition: Niagara Mohawk Power Corporation Dba National Grid Vs. Town of Cheektowaga, Assessor of the Town of Cheektowaga and the Board of Assessment Review
30. Notice of Petition: Verizon New York, Inc. (Formerly New York Telephone Company) Vs. Assessor of the Town of Cheektowaga and the Board of Assessment Review
31. Notice of Petition: International Paper Company Vs. Assessor of the Town of Cheektowaga; the Board of Assessment Review, and the Town of Cheektowaga
32. Notice of Petition: Commercial Net Lease Realty #515 Vs. Assessor of the Town of Cheektowaga; the Board of Assessment Review and the Town of Cheektowaga
33. Notice of Petition: C & S Wholesale Grocers Vs. Assessor of the Town of Cheektowaga; The Board of Assessment Review and the Town of Cheektowaga
34. Notice of Petition: US Foodservice Corporation Vs. Assessor of the Town of Cheektowaga; the Board of Assessment Review and the Town of Cheektowaga
35. Notice of Petition: Rite Aid of New York #1674 Vs. Assessor of the Town of Cheektowaga; the Board of Assessment Review and the Town of Cheektowaga, County of Erie, New York
36. Notice of Petition: Jetro Holdings Vs. Assessor of the Town of Cheektowaga; the Board of Assessment Review and the Town of Cheektowaga, Erie County, New York
37. Notice of Petition: Rite Aid Corporation/Eckerd Corporation Vs. Assessor of the Town of Cheektowaga; the Board of Assessment Review and the Town of Cheektowaga, Erie County, New York

38. Notice of Petition: Niagara Mohawk Power Corporation Dba National Grid Vs. Assessor of the Town of Cheektowaga; the Board of Assessment Review and the Town of Cheektowaga, Erie County, New York
39. Notice of Petition: Benderson Development and Its Various Properties Vs. Town of Cheektowaga, Assessor of the Town of Cheektowaga and the Board of Assessment Review
40. Notice of Petition: Gibraltar Steel Corporation Vs. Assessor, Board of Assessment Review and Town of Cheektowaga, NY
41. Notice of Petition: Idylwood LLC and Morgan Management Vs. Assessor, Board of Assessment Review and Town of Cheektowaga, NY
42. Notice of Petition: Wal-Mart Stores Inc and DDR MDT Union Concurer Square LLC Vs. Assessor, Board of Assessment Review and Town of Cheektowaga, NY
43. Notice of Petition: Quad Graphics Inc. Vs. Assessor, Board of Assessment Review and Town of Cheektowaga, NY
44. Notice of Petition: Lan-Clar Properties, LLC Vs. Assessor, Board of Assessment Review and Town of Cheektowaga, NY
45. Notice of Petition: Buffalo RHM Operating LLC Vs. Assessor, Board of Assessment Review and Town of Cheektowaga, NY
46. Notice of Petition: RE FUND Sky Harbor Property LLC Vs. Assessor, Board of Assessment Review and Town of Cheektowaga, NY
47. Notice of Petition: Cayuga Village South, LLC Vs. Town of Cheektowaga, Its Assessor, the Board of Assessment Review; Village of Depew and Depew Union Free School District

V. Comments

A. Supervisor's Comments

B. Councilmember's Comments

C. Public Comments

VI. Adjournment

Motion by Supervisor Holtz; Seconded by Councilmember Swiatek to adjourn the meeting at 7:02 PM.

Alice Magierski, Town Clerk



Town of Cheektowaga

Work Session

~ Minutes ~

3301 Broadway
Cheektowaga, NY 14227

<http://www.town.cheektowaga.ny.us>

Alice Magierski
716-686-3400

Tuesday, August, 9, 2011

6:00 PM

Council Office

I. Call to Order

6:00 PM Meeting called to order on August 9, 2011 at Council Office, Conference Room, Cheektowaga, NY.

Attendee Name	Organization	Title	Status	Arrived
Mary Holtz	Town of Cheektowaga	Supervisor	Present	
Patricia Jaworowicz	Town of Cheektowaga	Councilmember	Absent	
Jeff Swiatek	Town of Cheektowaga	Councilmember	Absent	
James Rogowski	Town of Cheektowaga	Councilmember	Present	
Richard Zydel	Town of Cheektowaga	Councilmember	Present	
Charles Markel	Town of Cheektowaga	Councilmember	Present	
Stanley Kaznowski	Town of Cheektowaga	Councilmember	Present	

II. Resolutions



1. RESOLUTION 2011-447

Settlement of Litigation - Fronckowiak V Town

Sponsored By: Supervisor Holtz, Councilmember Markel

WHEREAS, Michael Fronckowiak and Julie Fronckowiak commenced an Article 7 proceeding against the Town for Tax Year 2010-2011 seeking a reduction in the assessment of property owned by them and located at 11 Park Place (S.B.L. No. 114.18-7-20), Cheektowaga, New York; and

WHEREAS, the Town's outside Attorney consultant and the Town Assessor have reviewed the petition and, after due consideration of all materials facts, and after negotiations with the petitioner's attorney, believe it is in the best interest of the Town to resolve this matter without further litigation and strongly recommend the proposed compromise; NOW THEREFORE, BE IT

RESOLVED, that the Town Board approves the above compromise and settlement, and the Town's outside Attorney consultant and Town Assessor be and hereby are authorized to execute and procure all papers necessary to effectuate the settlement of said Article 7 proceeding.

RESULT:	ADOPTED [UNANIMOUS]
MOVER:	Mary Holtz, Supervisor
SECONDER:	Charles Markel, Councilmember
AYES:	Holtz, Rogowski, Zydel, Markel, Kaznowski
ABSENT:	Patricia Jaworowicz, Jeff Swiatek

III. Adjournment

Motion by Supervisor Holtz; Seconded by Councilmember Rogowski to end work session at 6:22 PM



Town of Cheektowaga

Regular Meeting

~ Minutes ~

3301 Broadway
Cheektowaga, NY 14227
<http://www.town.cheektowaga.ny.us>

Alice Magierski
716-686-3400

Monday, August, 15, 2011

6:45 PM

Council Chambers

I. Call to Order

6:45 PM Meeting called to order on August 15, 2011 at Council Chambers, 3301 Broadway St, Cheektowaga, NY.

Attendee Name	Organization	Title	Status	Arrived
Mary Holtz	Town of Cheektowaga	Supervisor	Present	
Patricia Jaworowicz	Town of Cheektowaga	Councilmember	Present	
Jeff Swiatek	Town of Cheektowaga	Councilmember	Present	
James Rogowski	Town of Cheektowaga	Councilmember	Present	
Richard Zydel	Town of Cheektowaga	Councilmember	Present	
Charles Markel	Town of Cheektowaga	Councilmember	Present	
Stanley Kaznowski	Town of Cheektowaga	Councilmember	Present	

2. Additional Attendees

Thomas Adamczak, Supervising Building and Plumbing Inspector
Brian Krause, Director of Finance and Administration
William Pugh, Town Engineer
Anthony Romano, Coordinator of Employee Relations
Mark Wegner, Highway Superintendent

II. Public Comment Period

III. Resolutions



1. RESOLUTION 2011-448

Transfer of Funds

Sponsored By: Supervisor Holtz, Councilmember Swiatek

BE IT RESOLVED, that the following transfer is hereby approved and made a part hereof;

HUD CDBG FUND

FROM:	700.1010.0602	Demolition	\$ 4,100.00
	700.1009.0602	Demolition	10,000.00
TO:	700.1010.0703	Administration	\$ 4,100.00
	700.1009.0606	Disposition	10,000.00

RESULT:	ADOPTED [UNANIMOUS]
MOVER:	Mary Holtz, Supervisor
SECONDER:	Jeff Swiatek, Councilmember
AYES:	Holtz, Jaworowicz, Swiatek, Rogowski, Zydel, Markel, Kaznowski



2. RESOLUTION 2011-449

Warrant

Sponsored By: Supervisor Holtz, Councilmember Swiatek

BE IT RESOLVED, that the following Vouchers & Warrants submitted to the Town of Cheektowaga prior to August 12, 2011 are hereby approved and made a part hereof;

GENERAL FUND	\$	457,535.57
RISK RETENTION FUND		26,445.01
NYS HOME PROGRAM		5,000.00
HUD HOUSING REHABILITATION		25,921.00
SPECIAL DISTRICTS FUND		254,411.10
HIGHWAY FUND		89,175.16
CAPITAL FUND		1,035,697.95
TRUST & AGENCY FUND		1,805.00
HUD CDBG FUND		5,746.39
PART TOWN FUND		4,667.87
NYS AFFORDABLE HOUSING		9,657.00
		<u>9,657.00</u>
	\$	1,916,062.05

RESULT: **ADOPTED [UNANIMOUS]**

MOVER: Mary Holtz, Supervisor

SECONDER: Jeff Swiatek, Councilmember

AYES: Holtz, Jaworowicz, Swiatek, Rogowski, Zydel, Markel, Kaznowski



3. RESOLUTION 2011-450

Award of Bid for Demolition of 89 Gardenvale Drive

Sponsored By: Councilmember Markel, Councilmember Kaznowski

WHEREAS, bids were advertised for the demolition with asbestos abatement of a two-story residential structure at 89 Gardenvale Drive; and

WHEREAS, bid proposals were received and opened on August 10, 2011 for said demolition; and

WHEREAS, the proposals were reviewed by the Town Attorney and, based on proposals submitted, the Town Attorney has recommended that this Town Board award the bid for the demolition of the structure on property located at 89 Gardenvale Drive to Buffalo Environmental Consultants, Inc., d/b/a AFI Environmental; NOW, THEREFORE, BE IT

RESOLVED, that this Town Board hereby awards the bid for the demolition with asbestos abatement of 89 Gardenvale Drive, Cheektowaga, New York, to:

Buffalo Environmental Consultants, Inc.,
d/b/a/ AFI Environmental
7815 Buffalo Avenue
P.O. Box 4049
Niagara Falls, New York 14304

for the bid price of \$17,850.00, being the lowest responsible bid meeting specifications, and BE IT FURTHER

RESOLVED, that the Supervisor be and hereby is directed to execute an agreement with Buffalo Environmental Consultants, Inc., for the aforesaid services, and BE IT FURTHER

RESOLVED, that moneys for said services shall be appropriated from budget line item number 0800-800-0440.

Attachments:

Demo Bid Tally (WPD)

RESULT: ADOPTED [UNANIMOUS]
MOVER: Charles Markel, Councilmember
SECONDER: Stanley Kaznowski, Councilmember
AYES: Holtz, Jaworowicz, Swiatek, Rogowski, Zydel, Markel, Kaznowski



4. RESOLUTION 2011-451

Award of Bid - Window Replacement at the Anna Reinstein Library

Sponsored By: Councilmember Rogowski, Supervisor Holtz

WHEREAS, the Town of Cheektowaga has been awarded state funding through the "New York State Construction Grant Program" which provides for various improvements to be made to the Anna Reinstein Memorial Library, AND

WHEREAS, a Notice to Bidders was published for the receipt of bids for window replacement to said library, which bids were duly received and opened on August 10, 2011, AND

WHEREAS, said bids were referred to the Town Engineer and to Trautman Associates, Project Architect, for analysis, tabulation and report, which is contained in a letter from Trautman Associates dated August 15, 2011, AND

WHEREAS, said report recommends the contract for window replacement be awarded to Flower City Glass, NOW, THEREFORE, BE IT

RESOLVED, that the contract for window replacement be and hereby is awarded to:

Flower City Glass
188 Mt. Hope Avenue
Rochester, New York 14620

for the base bid price of \$159,368.00, said being the lowest bid meeting the requirements of the specifications, AND, BE IT FURTHER

RESOLVED, that the Supervisor, on behalf of this Town Board, be and hereby is authorized and directed to execute the contract with said firm and any other documents necessary to effectuate completion of this project, AND, BE IT FURTHER

RESOLVED, that funding for said project shall be appropriated from budget line item No. 500-1440-2520-5135.

RESULT:	ADOPTED [UNANIMOUS]
MOVER:	James Rogowski, Councilmember
SECONDER:	Mary Holtz, Supervisor
AYES:	Holtz, Jaworowicz, Swiatek, Rogowski, Zydel, Markel, Kaznowski



5. RESOLUTION 2011-452

Notice to Bidders - Four (4) New Police Vehicles (Or Equivalent)

Sponsored By: Councilmember Jaworowicz, Councilmember Rogowski

BE IT RESOLVED, that the Town Clerk is hereby directed to publish a Notice to Bidders for the Purchase of four (4) New and Unused 2011 Ford Fusion Police Vehicles (or Equivalent) by the Cheektowaga Police Department, said notice to be published in the Cheektowaga Bee, AND, IT IS FURTHER

RESOLVED, that sealed bids will be received by the Town Clerk on the 24th day of August, 2011 at 11:00 A.M., at a public bid opening to be held in the Council Chambers in the Cheektowaga Town Hall, 3301 Broadway, Cheektowaga, NY 14227.

Notice to Bidders

Sealed proposals will be received by the Town Clerk of the Town of Cheektowaga on Wednesday, August 24, 2011 at 11:00 A.M. at Town Hall, corner of Broadway and Union Roads, for the purchase of four (4) New and Unused 2011 Ford Fusions (or Equivalent) as listed in the bid specifications.

The Town Board reserves the right to consider informal any bid not prepared and submitted in accordance with the provisions of the specifications and contract documents, and may waive any informalities, make an award to other than the low bidder, should it be in the best interest of the Town or reject any or all bids.

By the order of the Town Board of the Town of Cheektowaga, Erie County, New York.

Alice Magierski
Town Clerk

Table with 2 columns: Field (RESULT, MOVER, SECONDER, AYES) and Value (ADOPTED [UNANIMOUS], Patricia Jaworowicz, Councilmember, James Rogowski, Councilmember, Holtz, Jaworowicz, Swiatek, Rogowski, Zydel, Markel, Kaznowski)



6. RESOLUTION 2011-453

Call for Public Hearing - Special Use Permit (Drive Through)
3825 Union Road.

Sponsored By: Councilmember Kaznowski, Councilmember Markel

WHEREAS, Zaxis Architectural, P.C. on behalf of Key Bank and with the permission of the Owner, DDR Union Road, LLC has made application and requested a special use permit for the establishment of a stand alone drive through Automatic Teller Machine (ATM) at 3825 Union Road, NOW, THEREFORE BE IT

RESOLVED, that a Public Hearing be held regarding said request under the provisions of the Zoning Law on September 6, 2011 at 6:45 P.M., at the Cheektowaga Town Hall, 3301 Broadway at the corner of Union Road.

Notice of Public Hearing

NOTICE IS HEREBY GIVEN that a Public Hearing will be held by the Town Board of the Town of Cheektowaga, Erie County, New York at the Town Hall in the said Town of Cheektowaga, 3301 Broadway corner of Union Road on the 6th day of September, 2011 at 6:45 o'clock P.M., of said day for the purpose of considering the application of:

Zaxis Architectural, P.C. .

for a Special Use Permit for the establishment of a stand alone drive through Automatic Teller Machine (ATM) at 3825 Union.

All parties in interest and citizens will be given an opportunity to be heard in regard to such proposed application.

BY ORDER OF THE TOWN BOARD, Town of Cheektowaga, NY

Alice Magierski, TOWN CLERK

LEGAL DESCRIPTION

ALL THAT TRACT OR PARCEL OF LAND, situated in the Town of Cheektowaga, County of Erie and State of New York, being part of Lot No. 12, Township 11, Range 7 of the Holland Land Company's Survey described as follows:

BEGINNING at the point of intersection of the southeasterly line of lands of the West Shore Railroad Company with the easterly line of Union Road as now laid out and shown on a map recorded in the Erie County Clerk's Office in Liber 3838 of Deeds at page 56; running thence southerly along said easterly line of Union Road, 350.14 feet; thence southeasterly along a line drawn as shown on said map, 63.64 feet to the northerly line of George Urban Boulevard

as actually paved and used 80 feet wide; thence easterly along the northerly line of George Urban Boulevard, 894.94 feet; thence northerly at right angles to George Urban Boulevard, 593.96 feet to the northerly line of lands conveyed to Groveland Land Corporation by deed recorded in Liber 1951 of Deeds at page 26; thence westerly along said northerly line of Groveland Land Corporation, 608.30 feet to the southeasterly line of lands of the West Shore Railroad Company; thence southwesterly along the southeasterly line of lands of the West Shore Railroad Company, 384.66 feet to the easterly line of Union Road at the point or place of beginning.

RESULT:	ADOPTED [UNANIMOUS]
MOVER:	Stanley Kaznowski, Councilmember
SECONDER:	Charles Markel, Councilmember
AYES:	Holtz, Jaworowicz, Swiatek, Rogowski, Zydel, Markel, Kaznowski



7. RESOLUTION 2011-454

Notice of Hearing - Unsafe Building at 29E Glenwood Court

Sponsored By: Councilmember Markel, Councilmember Kaznowski

WHEREAS, the Supervising Code Enforcement Officer has received information that the building(s) located at **29E Glenwood Court** in the Town of Cheektowaga has become dangerous and unsafe to the general public and unfit for the purposes for which it may lawfully be used; and

WHEREAS, said building has been inspected and a written report of the condition has been completed by Nussbaumer & Clarke, Inc., duly authorized agent of the Town of Cheektowaga, setting forth its findings and recommendations in regard to the repair or demolition and removal of the building, and said written report describes extensive deterioration and damage to the building and premises and recommends that the building be demolished and removed; and

WHEREAS, the Town Board has fully considered such written report and has determined that the building is dangerous and unsafe to the general public and unfit for the purposes for which it may lawfully be used; NOW THEREFORE BE IT

RESOLVED, that this Town Board accepts the findings and recommendations of Nussbaumer & Clarke, Inc., dated July 1, 2011; and BE IT FURTHER

RESOLVED, that a notice shall be served, pursuant to Section 75-7 of the Cheektowaga Town Code, upon the owner, executor, administrator, agent, lessee or any person having a vested or contingent interest in such unsafe building as shown by the records of the Receiver of Taxes or of the County Clerk, which notice shall have the contents prescribed by Section 75-6 of said Town Code, including, but not limited to, a date, time and place for a hearing before the Town Board in relation to such dangerous and unsafe building, which hearing shall be scheduled not less than five business days from the date of service of the notice, and BE IT FURTHER

RESOLVED, that a hearing before this Board in relation to the dangerous and unsafe building at **29E Glenwood Court** shall be held on the 6th day of September, 2011, 6:45 P.M. at the Cheektowaga Town Hall, Council Chambers, 3301 Broadway, Cheektowaga, New York, and BE IT FURTHER

RESOLVED, that the Town Attorney's Office and/or the Code Enforcement Officer be and hereby is directed to serve a notice of said hearing on all interested parties.

RESULT:	ADOPTED [UNANIMOUS]
MOVER:	Charles Markel, Councilmember
SECONDER:	Stanley Kaznowski, Councilmember
AYES:	Holtz, Jaworowicz, Swiatek, Rogowski, Zydel, Markel, Kaznowski



8. RESOLUTION 2011-455

Notice of Hearing - Unsafe Building at 44A Windwood Court

Sponsored By: Councilmember Markel, Councilmember Kaznowski

WHEREAS, the Supervising Code Enforcement Officer has received information that the building(s) located at **44A Windwood Court** in the Town of Cheektowaga has become dangerous and unsafe to the general public and unfit for the purposes for which it may lawfully be used; and

WHEREAS, said building has been inspected and a written report of the condition has been completed by Nussbaumer & Clarke, Inc., duly authorized agent of the Town of Cheektowaga, setting forth its findings and recommendations in regard to the repair or demolition and removal of the building, and said written report describes extensive deterioration and damage to the building and premises and recommends that the building be demolished and removed; and

WHEREAS, the Town Board has fully considered such written report and has determined that the building is dangerous and unsafe to the general public and unfit for the purposes for which it may lawfully be used; NOW THEREFORE BE IT

RESOLVED, that this Town Board accepts the findings and recommendations of Nussbaumer & Clarke, Inc., dated July 1, 2011; and BE IT FURTHER

RESOLVED, that a notice shall be served, pursuant to Section 75-7 of the Cheektowaga Town Code, upon the owner, executor, administrator, agent, lessee or any person having a vested or contingent interest in such unsafe building as shown by the records of the Receiver of Taxes or of the County Clerk, which notice shall have the contents prescribed by Section 75-6 of said Town Code, including, but not limited to, a date, time and place for a hearing before the Town Board in relation to such dangerous and unsafe building, which hearing shall be scheduled not less than five business days from the date of service of the notice, and BE IT FURTHER

RESOLVED, that a hearing before this Board in relation to the dangerous and unsafe building at **44A Windwood Court** shall be held on the 6th day of September, 2011, 6:45 P.M. at the Cheektowaga Town Hall, Council Chambers, 3301 Broadway, Cheektowaga, New York, and BE IT FURTHER

RESOLVED, that the Town Attorney's Office and/or the Code Enforcement Officer be and hereby is directed to serve a notice of said hearing on all interested parties.

RESULT:	ADOPTED [UNANIMOUS]
MOVER:	Charles Markel, Councilmember
SECONDER:	Stanley Kaznowski, Councilmember
AYES:	Holtz, Jaworowicz, Swiatek, Rogowski, Zydel, Markel, Kaznowski



9. RESOLUTION 2011-456

Notice of Hearing - Unsafe Building at 95 Huth Road

Sponsored By: Councilmember Markel, Councilmember Kaznowski

WHEREAS, the Supervising Code Enforcement Officer has received information that the building(s) located at **95 Huth Road** in the Town of Cheektowaga has become dangerous and unsafe to the general public and unfit for the purposes for which it may lawfully be used; and

WHEREAS, said building has been inspected and a written report of the condition has been completed by Nussbaumer & Clarke, Inc., duly authorized agent of the Town of Cheektowaga, setting forth its findings and recommendations in regard to the repair or demolition and removal of the building, and said written report describes extensive deterioration and damage to the building and premises and recommends that the building be demolished and removed; and

WHEREAS, the Town Board has fully considered such written report and has determined that the building is dangerous and unsafe to the general public and unfit for the purposes for which it may lawfully be used; NOW THEREFORE BE IT

RESOLVED, that this Town Board accepts the findings and recommendations of Nussbaumer & Clarke, Inc., dated June 29, 2011, and BE IT FURTHER

RESOLVED, that a notice shall be served, pursuant to Section 75-7 of the Cheektowaga Town Code, upon the owner, executor, administrator, agent, lessee or any person having a vested or contingent interest in such unsafe building as shown by the records of the Receiver of Taxes or of the County Clerk, which notice shall have the contents prescribed by Section 75-6 of said Town Code, including, but not limited to, a date, time and place for a hearing before the Town Board in relation to such dangerous and unsafe building, which hearing shall be scheduled not less than five business days from the date of service of the notice, and BE IT FURTHER

RESOLVED, that a hearing before this Board in relation to the dangerous and unsafe building at **95 Huth Road** shall be held on the 6th day of September, 2011, 6:45 P.M. at the Cheektowaga Town Hall, Council Chambers, 3301 Broadway, Cheektowaga, New York, and BE IT FURTHER

RESOLVED, that the Town Attorney's Office and/or the Code Enforcement Officer be and hereby is directed to serve a notice of said hearing on all interested parties.

RESULT:	ADOPTED [UNANIMOUS]
MOVER:	Charles Markel, Councilmember
SECONDER:	Stanley Kaznowski, Councilmember
AYES:	Holtz, Jaworowicz, Swiatek, Rogowski, Zydel, Markel, Kaznowski



10. RESOLUTION 2011-457

Notice of Hearing - Unsafe Building at 74 Hoerner Ave.

Sponsored By: Councilmember Markel, Councilmember Kaznowski

WHEREAS, the Supervising Code Enforcement Officer has received information that the building(s) located at **74 Hoerner Avenue** in the Town of Cheektowaga has become dangerous and unsafe to the general public and unfit for the purposes for which it may lawfully be used; and

WHEREAS, said building has been inspected and a written report of the condition has been completed by Nussbaumer & Clarke, Inc., duly authorized agent of the Town of Cheektowaga, setting forth its findings and recommendations in regard to the repair or demolition and removal of the building, and said written report describes extensive deterioration and damage to the building and premises and recommends that the building be demolished and removed; and

WHEREAS, the Town Board has fully considered such written report and has determined that the building is dangerous and unsafe to the general public and unfit for the purposes for which it may lawfully be used; NOW THEREFORE BE IT

RESOLVED, that this Town Board accepts the findings and recommendations of Nussbaumer & Clarke, Inc., dated July 7, 2011, and BE IT FURTHER

RESOLVED, that a notice shall be served, pursuant to Section 75-7 of the Cheektowaga Town Code, upon the owner, executor, administrator, agent, lessee or any person having a vested or contingent interest in such unsafe building as shown by the records of the Receiver of Taxes or of the County Clerk, which notice shall have the contents prescribed by Section 75-6 of said Town Code, including, but not limited to, a date, time and place for a hearing before the Town Board in relation to such dangerous and unsafe building, which hearing shall be scheduled not less than five business days from the date of service of the notice, and BE IT FURTHER

RESOLVED, that a hearing before this Board in relation to the dangerous and unsafe building at **74 Hoerner Avenue** shall be held on the 6th day of September, 2011, 6:45 P.M. at the Cheektowaga Town Hall, Council Chambers, 3301 Broadway, Cheektowaga, New York, and BE IT FURTHER

RESOLVED, that the Town Attorney's Office and/or the Code Enforcement Officer be and hereby is directed to serve a notice of said hearing on all interested parties.

RESULT:	ADOPTED [UNANIMOUS]
MOVER:	Charles Markel, Councilmember
SECONDER:	Stanley Kaznowski, Councilmember
AYES:	Holtz, Jaworowicz, Swiatek, Rogowski, Zydel, Markel, Kaznowski



11. RESOLUTION 2011-458

Notice of Hearing - Unsafe Building at 305 Hyland Road

Sponsored By: Councilmember Markel, Councilmember Kaznowski

WHEREAS, the Supervising Code Enforcement Officer has received information that the building(s) located at **305 Hyland Road** in the Town of Cheektowaga has become dangerous and unsafe to the general public and unfit for the purposes for which it may lawfully be used; and

WHEREAS, said building(s) has been inspected and a written report of the condition has been completed by Nussbaumer & Clarke, Inc., duly authorized agent of the Town of Cheektowaga, setting forth its findings and recommendations in regard to the repair or demolition and removal of the building, and said written report describes extensive deterioration and damage to the building and premises and recommends that the building be demolished and removed; and

WHEREAS, the Town Board has fully considered such written report and has determined that the building(s) is dangerous and unsafe to the general public and unfit for the purposes for which it may lawfully be used; NOW THEREFORE BE IT

RESOLVED, that this Town Board accepts the findings and recommendations of Nussbaumer & Clarke, Inc., dated July 18, 2011; and BE IT FURTHER

RESOLVED, that a notice shall be served, pursuant to Section 75-7 of the Cheektowaga Town Code, upon the owner, executor, administrator, agent, lessee or any person having a vested or contingent interest in such unsafe building as shown by the records of the Receiver of Taxes or of the County Clerk, which notice shall have the contents prescribed by Section 75-6 of said Town Code, including, but not limited to, a date, time and place for a hearing before the Town Board in relation to such dangerous and unsafe building, which hearing shall be scheduled not less than five business days from the date of service of the notice, and BE IT FURTHER

RESOLVED, that a hearing before this Board in relation to the dangerous and unsafe building(s) at **305 Hyland Road** shall be held on the 6th day of September, 2011, 6:45 P.M. at the Cheektowaga Town Hall, Council Chambers, 3301 Broadway, Cheektowaga, New York, and BE IT FURTHER

RESOLVED, that the Town Attorney's Office and/or the Code Enforcement Officer be and hereby is directed to serve a notice of said hearing on all interested parties.

RESULT:	ADOPTED [UNANIMOUS]
MOVER:	Charles Markel, Councilmember
SECONDER:	Stanley Kaznowski, Councilmember
AYES:	Holtz, Jaworowicz, Swiatek, Rogowski, Zydel, Markel, Kaznowski



12. RESOLUTION 2011-459

Notice of Hearing - Unsafe Building at 3048 William Street

Sponsored By: Councilmember Markel, Councilmember Kaznowski

WHEREAS, the Supervising Code Enforcement Officer has received information that the building(s) located at **3048 William Street** in the Town of Cheektowaga has become dangerous and unsafe to the general public and unfit for the purposes for which it may lawfully be used; and

WHEREAS, said building has been inspected and a written report of the condition has been completed by Nussbaumer & Clarke, Inc., duly authorized agent of the Town of Cheektowaga, setting forth its findings and recommendations in regard to the repair or demolition and removal of the building(s), and said written report describes extensive deterioration and damage to the building(s) and premises and recommends that the building(s) be demolished and removed; and

WHEREAS, the Town Board has fully considered such written report and has determined that the building(s) is dangerous and unsafe to the general public and unfit for the purposes for which it may lawfully be used; NOW THEREFORE BE IT

RESOLVED, that this Town Board accepts the findings and recommendations of Nussbaumer & Clarke, Inc., dated August 10, 2011; and BE IT FURTHER

RESOLVED, that a notice shall be served, pursuant to Section 75-7 of the Cheektowaga Town Code, upon the owner, executor, administrator, agent, lessee or any person having a vested or contingent interest in such unsafe building as shown by the records of the Receiver of Taxes or of the County Clerk, which notice shall have the contents prescribed by Section 75-6 of said Town Code, including, but not limited to, a date, time and place for a hearing before the Town Board in relation to such dangerous and unsafe building, which hearing shall be scheduled not less than five business days from the date of service of the notice, and BE IT FURTHER

RESOLVED, that a hearing before this Board in relation to the dangerous and unsafe building(s) at **3048 William Street** shall be held on the 6th day of September, 2011, 6:45 P.M. at the Cheektowaga Town Hall, Council Chambers, 3301 Broadway, Cheektowaga, New York, and BE IT FURTHER

RESOLVED, that the Town Attorney's Office and/or the Code Enforcement Officer be and hereby is directed to serve a notice of said hearing on all interested parties.

RESULT:	ADOPTED [UNANIMOUS]
MOVER:	Charles Markel, Councilmember
SECONDER:	Stanley Kaznowski, Councilmember
AYES:	Holtz, Jaworowicz, Swiatek, Rogowski, Zydel, Markel, Kaznowski



13. RESOLUTION 2011-460

Notice of Hearing - Unsafe Building at 15 Atwood Place

Sponsored By: Councilmember Markel, Councilmember Kaznowski

WHEREAS, the Supervising Code Enforcement Officer has received information that the building(s) located at **15 Atwood Place** in the Town of Cheektowaga has become dangerous and unsafe to the general public and unfit for the purposes for which it may lawfully be used; and

WHEREAS, said building has been inspected and a written report of the condition has been completed by Nussbaumer & Clarke, Inc., duly authorized agent of the Town of Cheektowaga, setting forth its findings and recommendations in regard to the repair or demolition and removal of the building(s), and said written report describes extensive deterioration and damage to the building(s) and premises and recommends that the building(s) be demolished and removed; and

WHEREAS, the Town Board has fully considered such written report and has determined that the building(s) is dangerous and unsafe to the general public and unfit for the purposes for which it may lawfully be used; NOW THEREFORE BE IT

RESOLVED, that this Town Board accepts the findings and recommendations of Nussbaumer & Clarke, Inc., dated August 3, 2011; and BE IT FURTHER

RESOLVED, that a notice shall be served, pursuant to Section 75-7 of the Cheektowaga Town Code, upon the owner, executor, administrator, agent, lessee or any person having a vested or contingent interest in such unsafe building as shown by the records of the Receiver of Taxes or of the County Clerk, which notice shall have the contents prescribed by Section 75-6 of said Town Code, including, but not limited to, a date, time and place for a hearing before the Town Board in relation to such dangerous and unsafe building, which hearing shall be scheduled not less than five business days from the date of service of the notice, and BE IT FURTHER

RESOLVED, that a hearing before this Board in relation to the dangerous and unsafe building(s) at **15 Atwood Place** shall be held on the 6th day of September, 2011, 6:45 P.M. at the Cheektowaga Town Hall, Council Chambers, 3301 Broadway, Cheektowaga, New York, and BE IT FURTHER

RESOLVED, that the Town Attorney's Office and/or the Code Enforcement Officer be and hereby is directed to serve a notice of said hearing on all interested parties.

RESULT:	ADOPTED [UNANIMOUS]
MOVER:	Charles Markel, Councilmember
SECONDER:	Stanley Kaznowski, Councilmember
AYES:	Holtz, Jaworowicz, Swiatek, Rogowski, Zydel, Markel, Kaznowski



14. RESOLUTION 2011-461

Notice of Hearing - Unsafe Building at 1122 Walden Ave.

Sponsored By: Councilmember Markel, Councilmember Kaznowski

WHEREAS, the Supervising Code Enforcement Officer has received information that the building(s) located at **1122 Walden Avenue** in the Town of Cheektowaga has become dangerous and unsafe to the general public and unfit for the purposes for which it may lawfully be used; and

WHEREAS, said building has been inspected and a written report of the condition has been completed by Nussbaumer & Clarke, Inc., duly authorized agent of the Town of Cheektowaga, setting forth its findings and recommendations in regard to the repair or demolition and removal of the building, and said written report describes extensive deterioration and damage to the building and premises and recommends that the building be demolished and removed; and

WHEREAS, the Town Board has fully considered such written report and has determined that the building is dangerous and unsafe to the general public and unfit for the purposes for which it may lawfully be used; NOW THEREFORE BE IT

RESOLVED, that this Town Board accepts the findings and recommendations of Nussbaumer & Clarke, Inc., dated July 26, 2011, and BE IT FURTHER

RESOLVED, that a notice shall be served, pursuant to Section 75-7 of the Cheektowaga Town Code, upon the owner, executor, administrator, agent, lessee or any person having a vested or contingent interest in such unsafe building as shown by the records of the Receiver of Taxes or of the County Clerk, which notice shall have the contents prescribed by Section 75-6 of said Town Code, including, but not limited to, a date, time and place for a hearing before the Town Board in relation to such dangerous and unsafe building, which hearing shall be scheduled not less than five business days from the date of service of the notice, and BE IT FURTHER

RESOLVED, that a hearing before this Board in relation to the dangerous and unsafe building at **1122 Walden Avenue** shall be held on the 6th day of September, 2011, 6:45 P.M. at the Cheektowaga Town Hall, Council Chambers, 3301 Broadway, Cheektowaga, New York, and BE IT FURTHER

RESOLVED, that the Town Attorney's Office and/or the Code Enforcement Officer be and hereby is directed to serve a notice of said hearing on all interested parties.

RESULT:	ADOPTED [UNANIMOUS]
MOVER:	Charles Markel, Councilmember
SECONDER:	Stanley Kaznowski, Councilmember
AYES:	Holtz, Jaworowicz, Swiatek, Rogowski, Zydel, Markel, Kaznowski



15. RESOLUTION 2011-462

Negative SEQR Declaration-3198 Union Road

Sponsored By: Councilmember Kaznowski, Councilmember Markel

WHEREAS, pursuant to the Environmental Impact Review Ordinance of the Town of Cheektowaga, the Environmental Advisory Committee ("EAC") reviews various applications for site plans, rezonings, special permits, etc. and renders its recommendation concerning the environmental significance of such application, AND

WHEREAS, the Town Board, pursuant to the Environmental Impact Review Ordinance of the Town of Cheektowaga, is designated the Lead Agency in most instances, AND

WHEREAS, since the Town Board is the Lead Agency, it must affirm, modify or reject any recommendations submitted to it by the Advisory Committee, AND

WHEREAS, an application was submitted by Thomas j. Polinkas, President Lake Side Contracting, Co. for the construction of (2) two one story office buildings totaling 23,590 square feet in building area at 3198 Union Road , AND

WHEREAS, the Environmental Advisory Committee at its meetings held on August 10, 2011 recommended a determination of non-significance, AND

WHEREAS, the Town of Cheektowaga Planning Board recommended approval of the site plan at their meeting of July 14, 2011, AND

WHEREAS, this Town Board has reviewed the application submitted and the recommendations made by the Environmental Advisory Committee and the Planning Board, NOW, THEREFORE, BE IT

RESOLVED, that this Town Board determines that the project will not have a significant effect on the environment and therefore issues a Negative Declaration for purposes of SEQRA, AND BE IT

FURTHER RESOLVED, the proposed site plan is found to be acceptable subject to :

1. The Town engineer reviewing/approving the grading/drainage plan.
2. A pedestrian connection be established to the existing office building to the west.
3. The developer create a coordinated sign plan, to maintain a uniform appearance for signage consistent with what is shown on his/her architectural rendering.

RESULT:	ADOPTED [UNANIMOUS]
MOVER:	Stanley Kaznowski, Councilmember
SECONDER:	Charles Markel, Councilmember
AYES:	Holtz, Jaworowicz, Swiatek, Rogowski, Zydel, Markel, Kaznowski



16. RESOLUTION 2011-463

Accept Site Plan - 4821 Genesee Street

Sponsored By: Councilmember Markel, Councilmember Rogowski

WHEREAS, pursuant to the Zoning Law of the Town of Cheektowaga, the Planning Board reviews various development review applications for site plans, rezonings, special permits and realty subdivisions and renders its recommendation concerning the compatibility of such application with the zoning regulations, Town Master Plan and neighborhood character, AND

WHEREAS, the Town Board, pursuant to the Zoning Law of the Town of Cheektowaga, is required to affirm, modify or reject any recommendation submitted to it by the Planning Board, AND

WHEREAS, a development review application and site plan was submitted by Bella Vista Group on behalf of the landowner Samuel Tadio Trust for the construction of a 15,500 square foot veterinary clinic at 4821 Genesee Street, AND

WHEREAS, on November 2, 2009 the this Board previously issued a Negative SEQR Declaration and approved the site plan for the subject project, AND

WHEREAS, on November 3, 2010 the subject site plan expired pursuant to section 260-53B of the Town Zoning Law, as a consequence of the developers failure to file a building permit within one year of the original site plan approval, AND

WHEREAS, the Town of Cheektowaga Planning Board at its meeting of June 9, 2011 is recommending the re-approval of the site plan, AND

WHEREAS, this Town Board has reviewed the development review application and recommendations made by the Planning Board, NOW THEREFORE, BE IT

RESOLVED, that this Town Board determines that the project site plan is acceptable and re-affirms the Negative SEQR Declaration previously issued on November 2, 2009, AND

BE IT FURTHER RESOLVED, that this resolution corrects the property address and replaces resolution number 2011-382, approved on July 5, 2011.

RESULT:	ADOPTED [UNANIMOUS]
MOVER:	Charles Markel, Councilmember
SECONDER:	James Rogowski, Councilmember
AYES:	Holtz, Jaworowicz, Swiatek, Rogowski, Zydel, Markel, Kaznowski



17. RESOLUTION 2011-464

Accept Site Plan - 120 Losson Road - Wahl's Candies

Sponsored By: Councilmember Markel, Councilmember Rogowski

WHEREAS, pursuant to the Zoning Law of the Town of Cheektowaga, the Planning Board reviews various development review applications for site plans, rezonings, special permits and realty subdivisions and renders its recommendation concerning the compatibility of such application with the zoning regulations, Town Master Plan and neighborhood character, AND

WHEREAS, the Town Board, pursuant to the Zoning Law of the Town of Cheektowaga, is required to affirm, modify or reject any recommendation submitted to it by the Planning Board, AND

WHEREAS, a development review application and site plan was submitted by Mark Tiedemann, Architect for Wahl's Candies for the construction of a 2,000 square foot warehouse addition to an existing confectioners store at 120 Losson Road, AND

WHEREAS, the Town of Cheektowaga Planning Board at its meeting of March 10, 2011 is recommending the approval of the site plan, AND

WHEREAS, this Town Board has reviewed the development review application and recommendations made by the Planning Board, NOW THEREFORE, BE IT

RESOLVED, that this Town Board determines that the project site plan is acceptable.

RESULT:	ADOPTED [UNANIMOUS]
MOVER:	Charles Markel, Councilmember
SECONDER:	James Rogowski, Councilmember
AYES:	Holtz, Jaworowicz, Swiatek, Rogowski, Zydel, Markel, Kaznowski



18. RESOLUTION 2011-465

Accept Site Plan - 550 Dick Road - Duff's Famous Wings

Sponsored By: Councilmember Markel, Councilmember Rogowski

WHEREAS, pursuant to the Zoning Law of the Town of Cheektowaga, the Planning Board reviews various development review applications for site plans, rezonings, special permits and realty subdivisions and renders its recommendation concerning the compatibility of such application with the zoning regulations, Town Master Plan and neighborhood character, AND

WHEREAS, the Town Board, pursuant to the Zoning Law of the Town of Cheektowaga, is required to affirm, modify or reject any recommendation submitted to it by the Planning Board, AND

WHEREAS, a development review application and site plan was submitted by Kirk A. Feather for Duff's Famous Wings for the establishment of an exterior dining area at 550 Dick Road, AND

WHEREAS, the Town of Cheektowaga Planning Board at its meeting of June 9, 2011 is recommending the approval of the site plan, subject to the installation of a metal decorative fence adjacent to patio in lieu of the proposed metal rope barrier, AND

WHEREAS, this Town Board has reviewed the development review application and recommendations made by the Planning Board, NOW THEREFORE, BE IT

RESOLVED, that this Town Board determines that the project site plan is acceptable subject to :

1. The applicant revising his protective barrier as recommended by the Planning Board.
2. The applicant obtaining a building permit from the Building Inspections Office for the alterations to accommodate the dining area.

Attachments:

JUNE 2011 PLANNING BOARD MINUTES (PDF)

RESULT: ADOPTED [UNANIMOUS]
MOVER: Charles Markel, Councilmember
SECONDER: James Rogowski, Councilmember
AYES: Holtz, Jaworowicz, Swiatek, Rogowski, Zydel, Markel, Kaznowski



19. RESOLUTION 2011-466

Accept Site Plan - 2400 Clinton Street - Michael's Town Shanty

Sponsored By: Councilmember Markel, Councilmember Rogowski

WHEREAS, pursuant to the Zoning Law of the Town of Cheektowaga, the Planning Board reviews various development review applications for site plans, rezonings, special permits and realty subdivisions and renders its recommendation concerning the compatibility of such application with the zoning regulations, Town Master Plan and neighborhood character, AND

WHEREAS, the Town Board, pursuant to the Zoning Law of the Town of Cheektowaga, is required to affirm, modify or reject any recommendation submitted to it by the Planning Board, AND

WHEREAS, a development review application and site plan was submitted by Michael Sciandra for Michael's Town Shanty for the establishment of an exterior dining area at 2400 Clinton Street, AND

WHEREAS, the Town of Cheektowaga Planning Board at its meeting of May 12, 2011 is recommending the approval of the site plan, subject to the installation of a refuse enclosure for the existing dumpsters, AND

WHEREAS, this Town Board has reviewed the development review application and recommendations made by the Planning Board, NOW THEREFORE, BE IT

RESOLVED, that this Town Board determines that the project site plan is acceptable subject to :

1. The applicant constructing a refuse enclosure within (6) six months of this site plan acceptance.

Attachments:

PLANNING BOARD MINUTES MAY 2011 (PDF)

RESULT: ADOPTED [UNANIMOUS]
MOVER: Charles Markel, Councilmember
SECONDER: James Rogowski, Councilmember
AYES: Holtz, Jaworowicz, Swiatek, Rogowski, Zydel, Markel, Kaznowski



20. RESOLUTION 2011-467

Accept Site Plan - 3101 Broadway - Cameron Industries

Sponsored By: Councilmember Markel, Councilmember Rogowski

WHEREAS, pursuant to the Zoning Law of the Town of Cheektowaga, the Planning Board reviews various development review applications for site plans, rezonings, special permits and realty subdivisions and renders its recommendation concerning the compatibility of such application with the zoning regulations, Town Master Plan and neighborhood character, AND

WHEREAS, the Town Board, pursuant to the Zoning Law of the Town of Cheektowaga, is required to affirm, modify or reject any recommendation submitted to it by the Planning Board, AND

WHEREAS, a development review application and site plan was submitted by Scheid Architectural for Cameron Industries for the construction of a 3,024 square foot warehouse building at 3101 Broadway, AND

WHEREAS, the Town of Cheektowaga Planning Board at its meeting of July 14, 2011, is recommending the approval of the site plan, AND

WHEREAS, this Town Board has reviewed the development review application and recommendations made by the Planning Board, NOW THEREFORE, BE IT

RESOLVED, that this Town Board determines that the project site plan is acceptable.

RESULT:	ADOPTED [UNANIMOUS]
MOVER:	Charles Markel, Councilmember
SECONDER:	James Rogowski, Councilmember
AYES:	Holtz, Jaworowicz, Swiatek, Rogowski, Zydel, Markel, Kaznowski



21. RESOLUTION 2011-468

Accept Site Plan - 2090 Old Union Road - HVR Advanced Power Components

Sponsored By: Councilmember Markel, Councilmember Rogowski

WHEREAS, pursuant to the Zoning Law of the Town of Cheektowaga, the Planning Board reviews various development review applications for site plans, rezonings, special permits and realty subdivisions and renders its recommendation concerning the compatibility of such application with the zoning regulations, Town Master Plan and neighborhood character, AND

WHEREAS, the Town Board, pursuant to the Zoning Law of the Town of Cheektowaga, is required to affirm, modify or reject any recommendation submitted to it by the Planning Board, AND

WHEREAS, a development review application and site plan was submitted by LBM Construction, Inc on behalf of HVR Advanced Power Components for the construction of a 2,120 square foot manufacturing building addition at 2090 Old Union Road, AND

WHEREAS, the Town of Cheektowaga Planning Board at its meeting of April 14, 2011 is recommending the approval of the site plan, AND

WHEREAS, this Town Board has reviewed the development review application and recommendations made by the Planning Board, NOW THEREFORE, BE IT

RESOLVED, that this Town Board determines that the project site plan is acceptable subject to:

1. The Town Engineer's Review and Approval of the Drainage /Grading Plan.

RESULT:	ADOPTED [UNANIMOUS]
MOVER:	Charles Markel, Councilmember
SECONDER:	James Rogowski, Councilmember
AYES:	Holtz, Jaworowicz, Swiatek, Rogowski, Zydel, Markel, Kaznowski



22. RESOLUTION 2011-469

Accept Site Plan - 2268 Union Road - Culinary Arts Specialties

Sponsored By: Councilmember Markel, Councilmember Rogowski

WHEREAS, pursuant to the Zoning Law of the Town of Cheektowaga, the Planning Board reviews various development review applications for site plans, rezonings, special permits and realty subdivisions and renders its recommendation concerning the compatibility of such application with the zoning regulations, Town Master Plan and neighborhood character, AND

WHEREAS, the Town Board, pursuant to the Zoning Law of the Town of Cheektowaga, is required to affirm, modify or reject any recommendation submitted to it by the Planning Board, AND

WHEREAS, a development review application and site plan was submitted by Philip J. Silvestri, Architect for Culinary Arts Specialties, Inc. for the construction of a 1,500 square foot freezer warehouse addition at 2268 Union Road, AND

WHEREAS, the Town of Cheektowaga Planning Board at its meeting of July 14, 2011, is recommending the approval of the site plan, AND

WHEREAS, this Town Board has reviewed the development review application and recommendations made by the Planning Board, NOW THEREFORE, BE IT

RESOLVED, that this Town Board determines that the project site plan is acceptable subject to :

1. The Town Engineer reviewing and approving the drainage/grading plan.

RESULT:	ADOPTED [UNANIMOUS]
MOVER:	Charles Markel, Councilmember
SECONDER:	James Rogowski, Councilmember
AYES:	Holtz, Jaworowicz, Swiatek, Rogowski, Zydel, Markel, Kaznowski



23. RESOLUTION 2011-470

Authorize Supervisor to Execute Agreement for Electronic Waste Recycling for Residents

Sponsored By: Supervisor Holtz, Councilmember Swiatek

WHEREAS, on a regular basis, residents of the Town of Cheektowaga need to dispose of their obsolete and non-operational computers, monitors, printers, drives, fax machines and other electronic items, all of which contain hazardous materials (i.e., lead, mercury, etc.) and must be disposed of in an environmentally sound manner; and

WHEREAS, Edward Arnold Scrap Processors, Inc., ("Arnold") of Corfu, New York, an electronics recycling company, presently picks up Town-owned computers, etc. and disposes of same in full compliance with all government regulations applicable to the disposal of hazardous waste, and pays the Town \$.05 per pound for recovered materials (except CRT's); and

WHEREAS, Arnold has agreed to pick up and properly dispose of other computer and electronic equipment dropped off at the Highway Department by residents under the same arrangement, NOW, THEREFORE, BE IT

RESOLVED, that the Town hereby authorizes the Town Superintendent of Highways to set up a system for Edward Arnold Scrap Processors, Inc., to take possession of the discarded computer and electronic equipment dropped off at the Highway Department by Town residents, and dispose of same in full compliance with all applicable federal and state regulations governing the disposal of hazardous waste; and BE IT FURTHER

RESOLVED, that, subject to review and approval by the Town Attorney, the Supervisor of the Town of Cheektowaga be and hereby is authorized to execute an agreement and any other documents necessary effect the proper disposal of said equipment.

RESULT:	ADOPTED [UNANIMOUS]
MOVER:	Mary Holtz, Supervisor
SECONDER:	Jeff Swiatek, Councilmember
AYES:	Holtz, Jaworowicz, Swiatek, Rogowski, Zydel, Markel, Kaznowski



24. RESOLUTION 2011-471

Authorize Supervisor to Execute Grant Application for Justice Court

Sponsored By: Councilmember Jaworowicz, Councilmember Rogowski

WHEREAS, grant monies are available through the New York State Unified Court System to enhance the security and operation of municipal Justice Courts; NOW THEREFORE, BE IT

RESOLVED, that Grantmakers Advantage, Inc., the Town's grant consultants, be authorized and directed to complete the necessary application, forms, etc. to be submitted to the New York State Unified Court System for the purpose of securing this grant; and BE IT FURTHER

RESOLVED, that the Supervisor and Town Court Justices be and hereby are authorized and directed to execute all documents pertaining to the application and acquisition of said funding.

RESULT:	ADOPTED [UNANIMOUS]
MOVER:	Patricia Jaworowicz, Councilmember
SECONDER:	James Rogowski, Councilmember
AYES:	Holtz, Jaworowicz, Swiatek, Rogowski, Zydel, Markel, Kaznowski



25. RESOLUTION 2011-472

Termination of Part-Time Seasonal Employees

Sponsored By: Councilmember Swiatek, Supervisor Holtz

BE IT RESOLVED, that the following seasonal and/or part-time employees be and hereby are terminated as listed:

TAX OFFICE

Eleanor A. Kantowski effective 5/28/11

SANITATION DEPARTMENT

Nicholas C. Scaccia effective 7/22/11

Gary A. Slawiak effective 7/23/11

MAIN PUMP STATION

Ronald A. Strong effective 7/30/11

Motion by Councilmember Rogowski: Seconded by Councilmember Markel to waive the reading of names for this resolution. Motion Carried

RESULT: ADOPTED [UNANIMOUS]

MOVER: Jeff Swiatek, Councilmember

SECONDER: Mary Holtz, Supervisor

AYES: Holtz, Jaworowicz, Swiatek, Rogowski, Zydel, Markel, Kaznowski



26. RESOLUTION 2011-473

Reappointment to Board of Ethics (Jeanne Pawlik)

Sponsored By: Supervisor Holtz, Councilmember Markel

WHEREAS, the term of Jeanne Pawlik as Member of the Board of Ethics expired on August 1, 2011, AND

WHEREAS, the Board of Ethics has recommended that Mrs. Pawlik be reappointed to serve on the Board of Ethics for another term, AND

WHEREAS, Mrs. Pawlik has expressed an interest in being reappointed to the Board of Ethics, NOW, THEREFORE, BE IT

RESOLVED, that Jeanne Pawlik, of Cheektowaga, New York be and hereby is reappointed to the Board of Ethics, effective August 1, 2011 and expiring on August 1, 2016.

RESULT:	ADOPTED [UNANIMOUS]
MOVER:	Mary Holtz, Supervisor
SECONDER:	Charles Markel, Councilmember
AYES:	Holtz, Jaworowicz, Swiatek, Rogowski, Zydel, Markel, Kaznowski

**27. RESOLUTION 2011-474****Amendment of Title from General Mechanic to Maintenance Worker (Non-Competitive/Permanent)/Peter M. Kreavy, Jr./Facilities Department)**

Sponsored By: Councilmember Swiatek, Supervisor Holtz

WHEREAS, a vacancy exists in the position of General Mechanic in the Facilities Department (Building Maintenance Division); AND

WHEREAS, notice of such vacancy has been posted in accordance with the provisions of the Town's collective bargaining agreement with the Town of Cheektowaga Employees Association; AND

WHEREAS, no bargaining unit member bid on said vacancy; AND

WHEREAS, Peter M. Kreavy, Jr., was appointed to the position of General Mechanic in the Facilities Department (Building Maintenance Division) effective August 2, 2011; AND

WHEREAS, the Town of Cheektowaga Employees Association has agreed to change the title of said position to that of Maintenance Worker; AND

WHEREAS, Peter M. Kreavy, Jr. meets the qualifications for appointment; NOW, THEREFORE, BE IT

RESOLVED, that Peter M. Kreavy, Jr. of Cheektowaga, New York, be and hereby is appointed to the position of Maintenance Worker in the Facilities Department (Building Maintenance Division), pursuant to the terms and conditions as set forth in the collective bargaining agreement between the Town of Cheektowaga and the Town of Cheektowaga Employees Association effective August 2, 2011.

RESULT:	ADOPTED [UNANIMOUS]
MOVER:	Jeff Swiatek, Councilmember
SECONDER:	Mary Holtz, Supervisor
AYES:	Holtz, Jaworowicz, Swiatek, Rogowski, Zydel, Markel, Kaznowski



28. RESOLUTION 2011-475

Appointment of Laborer (Labor/Permanent) Highway Department/Alan R. Bakowski

Sponsored By: Councilmember Swiatek, Supervisor Holtz

WHEREAS, a vacancy exists in the title of Laborer in the Highway Department; AND

WHEREAS, notice of such vacancy has been posted in accordance with the provisions of the Town's collective bargaining agreement with the Town of Cheektowaga Employees Association; AND

WHEREAS, no full-time bargaining unit member bid on said vacancy; AND

WHEREAS, Alan R. Bakowski, currently employed as a temporary Laborer in the Highway Department, applied for said vacancy and meets the qualifications for appointment; NOW, THEREFORE, BE IT

RESOLVED, that Alan R. Bakowski of Cheektowaga, New York, be and hereby is appointed to the position of Laborer in the Highway Department in accordance with the terms and conditions of the Town's collective bargaining agreement with the Town of Cheektowaga Employees Association effective August 8, 2011.

RESULT:	ADOPTED [UNANIMOUS]
MOVER:	Jeff Swiatek, Councilmember
SECONDER:	Mary Holtz, Supervisor
AYES:	Holtz, Jaworowicz, Swiatek, Rogowski, Zydel, Markel, Kaznowski

**29. RESOLUTION 2011-476****Appointment of Park Maintenance Worker I
(Labor/Permanent) Facilities Department (Parks
Division)/James R. Siejak**

Sponsored By: Councilmember Swiatek, Supervisor Holtz

WHEREAS, a vacancy exists in the title of Park Maintenance Worker I in the Facilities Department (Parks Division); AND

WHEREAS, notice of said vacancy has been posted in accordance with the provisions of the Town's collective bargaining agreement with the Town of Cheektowaga Employees Association; AND

WHEREAS, no full-time bargaining unit employee bid on said vacancy; AND

WHEREAS, James R. Siejak, of Cheektowaga, New York, applied for said position and meets the necessary qualifications for appointment; NOW, THEREFORE, BE IT

RESOLVED, that James R. Siejak, of Cheektowaga, New York, be and hereby is appointed to the position of Park Maintenance Worker I in the Facilities Department (Parks Division) in accordance with the terms and conditions of the Town's collective bargaining agreement with the Town of Cheektowaga Employees Association effective August 16, 2011.

RESULT:	ADOPTED [UNANIMOUS]
MOVER:	Jeff Swiatek, Councilmember
SECONDER:	Mary Holtz, Supervisor
AYES:	Holtz, Jaworowicz, Swiatek, Rogowski, Zydel, Markel, Kaznowski



30. RESOLUTION 2011-477

Travel Authorization Office of Town Assessor/Town Assessor Jeneen McSkimming

Sponsored By: Councilmember Swiatek, Supervisor Holtz

WHEREAS, the New York State Assessment Administration Seminar is being held September 11 through September 14, 2011 in Buffalo, New York; AND

WHEREAS, Town Assessor Jeneen McSkimming has requested authorization to attend said seminar; AND

WHEREAS, Ms. McSkimming has submitted a request for travel authorization along with the proper paperwork in a timely manner; AND

WHEREAS, the total cost to the Town shall not exceed \$272; AND

WHEREAS, these expenses have been budgeted by the Office of the Town Assessor;
NOW, THEREFORE, BE IT

RESOLVED, that Town Assessor Jeneen McSkimming be and hereby is authorized to attend the New York State Assessment Administration Seminar being held September 11 through September 14, 2011 in Buffalo, New York.

RESULT:	ADOPTED [UNANIMOUS]
MOVER:	Jeff Swiatek, Councilmember
SECONDER:	Mary Holtz, Supervisor
AYES:	Holtz, Jaworowicz, Swiatek, Rogowski, Zydel, Markel, Kaznowski

**31. RESOLUTION 2011-478****Travel Authorization Justice Court/Town Justices Thomas S. Kolbert and Dennis A. Delano**

Sponsored By: Councilmember Jaworowicz, Councilmember Swiatek

WHEREAS, the 2011 Annual Conference of the New York State Association of Magistrates Court Clerks is being held September 25 through September 28, 2011 in Niagara Falls, New York; AND

WHEREAS, Town Justices Thomas S. Kolbert and Dennis A. Delano have requested authorization to attend said conference; AND

WHEREAS, the Town Justices have submitted a request for travel authorization along with the proper paperwork in a timely manner; AND

WHEREAS, the total cost to the Town shall not exceed \$249.06; AND

WHEREAS, these expenses have been budgeted by the Justice Court; NOW, THEREFORE, BE IT

RESOLVED, that Town Justices Thomas S. Kolbert and Dennis A. Delano be and hereby are authorized to attend the 2011 Annual Conference of the New York State Association of Magistrates Court Clerks being held September 25 through September 28, 2011 in Niagara Falls, New York.

RESULT:	ADOPTED [UNANIMOUS]
MOVER:	Patricia Jaworowicz, Councilmember
SECONDER:	Jeff Swiatek, Councilmember
AYES:	Holtz, Jaworowicz, Swiatek, Rogowski, Zydel, Markel, Kaznowski

**32. RESOLUTION 2011-479****Travel Authorization Police Department/Police Officer Jeffrey Schmidt**

Sponsored By: Councilmember Jaworowicz, Councilmember Swiatek

WHEREAS, an Advanced Sniper/Observer Course is being held August 1 through August 5, 2011 in Olean, New York; AND

WHEREAS, Police Officer Jeffrey Schmidt has requested authorization to attend said course; AND

WHEREAS, Police Chief David Zack has submitted a request for travel authorization along with the proper paperwork in a timely manner; AND

WHEREAS, the total cost to the Town shall not exceed \$438; AND

WHEREAS, these expenses have been budgeted by the Police Department; NOW, THEREFORE, BE IT

RESOLVED, that Police Officer Jeffrey Schmidt be and hereby is authorized to attend the Advanced Sniper/Observer Course being held August 1 through August 5, 2011 in Olean, New York.

RESULT:	ADOPTED [UNANIMOUS]
MOVER:	Patricia Jaworowicz, Councilmember
SECONDER:	Jeff Swiatek, Councilmember
AYES:	Holtz, Jaworowicz, Swiatek, Rogowski, Zydel, Markel, Kaznowski



33. RESOLUTION 2011-480

Travel Authorization Police Department/Police Chief David Zack, Sergeant Lawrence Bauer and Police Officer Thomas Rogers

Sponsored By: Councilmember Jaworowicz, Councilmember Swiatek

WHEREAS, a Range Room Tour will be held on August 22 through August 24, 2011 in Cincinnati, Ohio; AND

WHEREAS, Police Chief David Zack, Sergeant Lawrence Bauer and Police Officer Thomas Rogers have requested authorization to attend said tour; AND

WHEREAS, Police Chief Zack has submitted a request for travel authorization along with the proper paperwork in a timely manner; AND

WHEREAS, the total cost to the Town shall not exceed \$812.84; AND

WHEREAS, these expenses have been budgeted by the Police Department; NOW, THEREFORE, BE IT

RESOLVED, that Police Chief David Zack, Sergeant Lawrence Bauer and Police Officer Thomas Rogers be and hereby are authorized to attend the Range Room Tour being held August 22 through August 24, 2011 in Cincinnati, Ohio.

RESULT:	ADOPTED [UNANIMOUS]
MOVER:	Patricia Jaworowicz, Councilmember
SECONDER:	Jeff Swiatek, Councilmember
AYES:	Holtz, Jaworowicz, Swiatek, Rogowski, Zydel, Markel, Kaznowski

IV. Suspension of Rules

Motion by Supervisor Holtz; Seconded by Councilmember Rogowski to Suspend the Rules to Include the Following Two (2) Resolutions: 2011-481 and 2011-282. Motion Carried.
--



1. RESOLUTION 2011-481

Change Order No. 1 for Contract for Demolition of 1112 Walden Avenue

Sponsored By: Councilmember Markel, Councilmember Kaznowski

WHEREAS, the contract for the demolition of property located at 1112 Walden Avenue was awarded to Hannah Demolition, Inc., by resolution dated April 18, 2011 (Resolution 2011-215) for the contract amount of \$18,200.00; and

WHEREAS, subsequent to said bid award, the Town was notified that there was an additional 850 square feet of asbestos tile hidden under a newer flooring and subflooring in the structure that was not part of the bid specifications; and

WHEREAS, the removal of said asbestos material will cost an additional \$4,200.00, and

WHEREAS, the Managing Housing Inspector recommends the approval of Change Order No. 1 (final) which provides for contract modifications for the removal of the additional asbestos materials at 1112 Walden Avenue; NOW, THEREFORE, BE IT

RESOLVED, that this Town Board hereby accepts the revised project and directs the Supervisor to execute the necessary Change Order No. 1 document with Hannah Demolition, Inc., which provides for an increase to the aforesaid contract in the amount of \$4,200.00, which shall be chargeable to budget line item number 800-0800-0440.

RESULT:	ADOPTED [UNANIMOUS]
MOVER:	Charles Markel, Councilmember
SECONDER:	Stanley Kaznowski, Councilmember
AYES:	Holtz, Jaworowicz, Swiatek, Rogowski, Zydel, Markel, Kaznowski



2. RESOLUTION 2011-482

Purchase of Microwave Link Equipment

Sponsored By: Supervisor Holtz, Councilmember Markel

WHEREAS, Cheektowaga Central School District, Cheektowaga Maryvale Union Free School District, Cheektowaga Sloan Union Free School District, Cleveland Hill Union Free School District and Harkness Career & Technical Center (hereinafter collectively referred to as "School Districts") utilize surveillance cameras in their hallways, etc., and

WHEREAS, the School Districts desire to have the Town, through its Police Department, monitor the aforesaid surveillance camera video stream for the safety of the school children, teachers, etc., and

WHEREAS, video streams from the aforesaid cameras will be relayed to the Town Police Department Dispatch Center (hereinafter referred to as "Dispatch Center") via microwave links from Erie BOCES building located at 355 Harlem Road, West Seneca (hereinafter referred to as the "Erie BOCES building"), and

WHEREAS, the Town needs to purchase equipment for this project, and

WHEREAS, a written Request for Proposals was issued for the installation of a 5.8GHZ Microwave link from the Cheektowaga Police Department to the BOCES building at 355 Harlem Road, and proposals for said equipment were obtained, and

WHEREAS, the Town Department of Information Services has evaluated the proposals and has recommended that this Town award a contract to Saia Communications, Inc. for \$30,872.70 for this project, NOW, THEREFORE, BE IT

RESOLVED, that the contract for the installation of a 5.8GHz Microwave link from the Cheektowaga Police Department to the BOCES building at 355 Harlem Road be and hereby is awarded to Saia Communications, Inc. for \$30,872.70, and BE IT FURTHER

RESOLVED, that funding for said project is being paid for by the School Districts and is available from budget line item number 100-1680-2202.

RESULT:	ADOPTED [UNANIMOUS]
MOVER:	Mary Holtz, Supervisor
SECONDER:	Charles Markel, Councilmember
AYES:	Holtz, Jaworowicz, Swiatek, Rogowski, Zydel, Markel, Kaznowski

V. Communications

A. Departmental Communications

1. Minutes: Town Environmental Advisory Committee - August 10, 2011

2. Drescher & Malecki, LLP: Auditor's Communication Letter
3. Drescher & Malecki, LLP: Management Letter
4. Comprehensive Annual Financial Report of the Town of Cheektowaga, Erie County, New York for the Fiscal Year Ended December 31, 2010
5. Supplement to the Comprehensive Annual Financial Report for the Town of Cheektowaga, Erie County, New York for the Fiscal Year Ended December 31, 2010
6. Town of Cheektowaga, New York Statement of Changes in Cash Balances and Statements of Cash Receipts and Disbursements of the Receiver of Taxes and Assessments, the Town Clerk and the Town Justices for the Year Ended December 31, 2010 and Independent Auditors' Report
7. Town of Cheektowaga, New York - Basic Financial Statements, Required Supplementary Information, Supplemental and Federal Financial Assistance Schedules for the Year Ended December 31, 2010 and Independent Auditors' Reports
8. Town of Cheektowaga, New York - New York State Department of Transportation Financial Assistance Schedules for the Year Ended December 31, 2010 and Independent Auditors' Report

B. General Communications

1. Notice of Claim: Michelle Bykowski Vs. Town of Cheektowaga
2. Notice of Claim: Louise O Cerrone Vs. Town of Cheektowaga
3. Notice of Claim: Jesse Herr Vs. Town of Cheektowaga
4. Notice of Claim: Liberty Mutual Fire Insurance Co Aso Eugene Glab Vs. Town of Cheektowaga
5. Notice of Claim: Maria Mato Vs. Town of Cheektowaga
6. Notice of Claim: Sandra Morath Vs. Town of Cheektowaga
7. Notice of Petition: Sterling Associates, LLC Vs. the Board of Assessment Review for the Town of Cheektowaga; Assessor for the Town of Cheektowaga, Erie County, New York; the Town of Cheektowaga New York the Cheektowaga Central School District and the County of Erie
8. Notice of Petition: Windwood Place, LLC Vs. Jeneen McSkimming, Assessor and the Board of Assessment Review of the Town of Cheektowaga
9. Notice of Petition: 825 Rein Road LLC Vs. Board of Assessment Review for the Town of Cheektowaga, Assessor for the Town of Cheektowaga
10. Notice of Petition: Paul Lamparelli Vs. the Board of Assessment Review for the Town of Cheektowaga, Assessor and the Town of Cheektowaga
11. Notice of Petition: Sterling Associates, LLC Vs. the Board of Assessment Review for the Town of Cheektowaga, Assessor the The Town of Cheektowaga; the Town of Cheektowaga; Cheektowaga Central School District and the County of Erie

12. Notice of Petition: 2555 Walden Avenue LLC Vs. the Board of Assessment Review of the Town of Cheektowaga, Assessor for the Town of Cheektowaga and the Town of Cheektowaga
13. Notice of Petition: 3018-3036 Genesee Street Inc. Vs. the Board of Assessment Review for the Town of Cheektowaga, Assessor for the Town of Cheektowaga and the Town of Cheektowaga
14. Notice of Petition: Paul Marinaccio Vs. Jeneen McSkimming, Assessor of the Town of Cheektowaga, the Board of Assessment Review for the Town of Cheektowaga and Cheektowaga Assessor's Office
15. Notice of Petition: MVP Airport, LLC Vs. Assessor of the Town of Cheektowaga, the Board of Assessment Review of the Town of Cheektowaga and Town of Cheektowaga, County of Erie, State of New York

VI. Comments

A. Supervisor's Comments

B. Councilmember's Comments

C. Public Comments

VII. Adjournment

Motion by Supervisor Holtz; Seconded by Councilmember Swiatek to adjourn the meeting in memory of Jeanette Kaczmarek, who was an election inspector for many years.

Alice Magierski, Town Clerk

CHEEKTOWAGA PLANNING BOARD

MINUTES FROM MEETING OF JUNE 9TH, 2011

REGULAR MEETING WAS CALLED TO ORDER OF THE PLANNING BOARD OF THE TOWN OF CHEEKTOWAGA, ERIE COUNTY, NEW YORK AT THE TOWN HALL COUNCIL CHAMBERS IN SAID TOWN OF CHEEKTOWAGA JUNE 9TH, 2011 AT 7:00PM

PLEDGE LED BY MR. MARRIOTT

Members: All Present

Motion to accept and dispense with the reading of the May Meeting Minutes by Mr. Kucewicz and 2nd by Mrs. Casacci. Motion carried

OLD BUSINESS:

ITEM 1 61 & 63 Anderson Rd., 88 Room 5 story Hotel
Site Plan, Architectural Character

The Planning Board unanimously recommended site plan approval for the 88 room, 5 story hotel, based on drawings submitted to the Planning Board at the June 9 meeting showing the future 50 room, 4 story hotel aligned parallel with the south property line. The area for the future hotel will remain green until time of construction. Applicant will work out final details for the internal pedestrian walkways and sidewalk location with the Town Planner.

The Planning Board recommended architectural approval for the Holiday Inn Express building per the 3-D renderings submitted to Planning Board at the June 9 meeting. Colors will be earth tones with masonry accents.

NEW BUSINESS

ITEM 1 Galleria Drive/Gordon Biersch Restaurant
Site Plan for Outdoor Dining Area

Recommended unanimous Town Board approval for the outdoor dining area per the revised site plan drawing submitted to the planning Board at the June 9 meeting.

ITEM 2 550 Dick Road, Duff's Famous Wings
Site Plan Outdoor Dining Area

Unanimously recommended Town Board approval for an 18 seat outdoor dining area per the site plan drawing dated 5-31-11 and submitted to the Planning Board at the June 9 meeting. The Planning Board requested the applicant install a permanent wood or metal fence approximately 3 ft. high around the proposed outdoor dining area as opposed to the proposed rope fence.

ITEM 3 4217 Genesee St., Quality Inn
 Parking Area Expansion

The Planning Board unanimously recommended site plan approval for an 88 parking area addition to the existing Quality Inn project. The applicant was requested to provide low-level lighting in the parking area to minimize the ambient light in the surrounding area.

ITEM 4 4795 & 4825 Genesee St. Veterinary Clinic
 Reapprove Expired Site Plan

The Planning Board recommended re-approval of the previous site plan with no changes.

Motion made and seconded to adjourn.

Respectfully submitted,

Joan C. Meyers, Secretary
Cheektowaga Planning Board

JM/jcm

CHEEKTOWAGA PLANNING BOARD

MINUTES FROM MEETING OF MAY 12, 2011

REGULAR MEETING WAS CALLED TO ORDER OF THE PLANNING BOARD OF THE TOWN OF CHEEKTOWAGA, ERIE COUNTY, NEW YORK AT THE TOWN HALL COUNCIL CHAMBERS IN SAID TOWN OF CHEEKTOWAGA MAY 12, 2011 AT 7:00PM

PLEDGE LED BY MRS. CASSACCI

Members: Joan Adams, excused; Sigmund Kucewicz *present*; John Marriott, *present*; Joan Meyers, present; Ruth Casacci, *Present*.

Motion to accept and dispense with the reading of the April Meeting Minutes by Mr. Kucewicz and 2nd by Mrs. Casacci. Motion carried

OLD BUSINESS:

ITEM 1 RUSINIAK'S 2916 UNION ROAD

PUBLIC HEARING WAS HELD AND THERE WERE NO OBJECTIONS TO THE REZONING. A MOTION WAS MADE BY MS. MEYERS AND SECONDED BY MRS. CASACCI TO RECOMMEND APPROVAL OF THE REZONING. ALL IN FAVOR.

NEW BUSINESS:

ITEM 1 2460 CLINTON STREET
 AMENDMENT TO PREVIOUSLY APPROVED SITE PLAN

APPLICANT AND NEIGHBOR MADE AN AGREEMENT TO ERECT A 6 FT. REAR AND FRONT FENCE. A MOTION WAS MADE BY MRS. CASACCI AND SECONDED BY MR. KUCEWICZ TO RECOMMEND APPROVAL OF SITE PLAN. ALL IN FAVOR.

ITEM 2 2400 CLINTON ST.
 TOWN SHANTY

APPLICANT IS REQUESTING TO ERECT A 26 FT. RAILING TO ENCLOSE EXISTING AREA SO HE CAN PUT 4 TABLES OUTSIDE FOR DINING WHICH WILL NOT CHANGE ANY FLOW OF TRAFFIC. FOR SAFETY REASONS HE WILL ELIMINATE 3 PARKING SPACES IN FRONT. APPLICANT HAS ALSO BEEN ASKED TO HAVE COVER FOR DUMPSTER. A MOTION WAS MADE BY MRS. CACASSI AND SECONDED BY MS. MEYERS TO RECOMMEND APPROVAL FOR SITE PLAN CONTINGENT ON DUMPSTER COVER. ALL IN FAVOR.

ITEM 3 3825 UNION RD.
 KEY BANK/ZAXIS ARCHITECTURAL

ARCHITECT IN ATTENDANCE WITH SITE PLAN.

KEY BANK DESIRES TO PROVIDE A SINGLE LANE DRIVE-THRU ATM KIOSK WHICH IS NOT AN OCCUPIED BUILDING. A MOTION WAS MADE BY MR. KUCEWICZ AND SECONDED BY MRS. CASACCI TO RECOMMEND APPROVAL OF THE SITE PLAN/SPECIAL PERMIT. ALL IN FAVOR.

ITME 4 5090 – 5100 GENESEE ST.
 GENESEE TRANSIT HOLDINGS V11, LLC

THIS PROJECT IS TO DEVELOP A 7515 SF STRIP PLAZA ON .98 ACRES OF PROPERTY FOR RETAIL OR FOOD USE OR ANY LEGALLY APPROVED USE. THERE WILL BE 2 ENTRANCES, 1 ON TRANSIT AND 1 ON GENESEE ST. LANDSCAPING IS ALL IN PLACE. A MOTION WAS MADE BY MS. MEYERS AND SECONDED BY MRS. CASACCI TO RECOMMEND APPROVAL TO THE PREVIOUSLY APPROVED SITE PLAN. ALL IN FAVOR.

ITEM 5 3600 GENESEE ST.
 KELLER CHEVROLET

THIS PROJECT IS FOR A 2200 SF ADDITION TO THE EXISTING AUTOMOTIVE SHOWROOM AND A 667 SF ADDITION TO THE EXISTING SERVICE DRIVE LANE. EXTERIOR PARKING IS MODIFIED DUE TO AREA'S OF ADDITION. DRAINAGE AND LANDSCAPING ARE UNCHANGED. A MOTION WAS MADE BY MRS. CASACCI AND SECONDED BY MR. KUCEWICZ TO RECOMMEND APPROVAL OF THE SITE PLAN. ALL IN FAVOR.

PRELIMINARY REVIEW

3198 UNION RD. ADVANCE DESIGN AGENCY SITE PLAN/2 OFFICE BUILDINGS

MOTION MADE AND SECONDED TO ADJOURN. ALL IN FAVOR

RESPECFULLY SUBMITTED,

JOAN C. MEYERS, SECRETARY
 CHEEKTOWAGA PLANNING BOARD



Town of Cheektowaga

Work Session

~ Minutes ~

3301 Broadway
Cheektowaga, NY 14227

<http://www.town.cheektowaga.ny.us>

Alice Magierski
716-686-3400

Tuesday, August, 30, 2011

6:00 PM

Council Office

I. Call to Order

6:00 PM Meeting called to order on August 30, 2011 at Council Office, Conference Room, Cheektowaga, NY.

Attendee Name	Organization	Title	Status	Arrived
Mary Holtz	Town of Cheektowaga	Supervisor	Present	
Patricia Jaworowicz	Town of Cheektowaga	Councilmember	Present	
Jeff Swiatek	Town of Cheektowaga	Councilmember	Present	
James Rogowski	Town of Cheektowaga	Councilmember	Present	
Richard Zydel	Town of Cheektowaga	Councilmember	Present	
Charles Markel	Town of Cheektowaga	Councilmember	Present	
Stanley Kaznowski	Town of Cheektowaga	Councilmember	Present	

2. Additional Attendees

Brian Krause, Director of Finance and Administration
Anthony Romano, Coordinator of Employee Relations
Kevin Schenk, Town Attorney
David Zack, Chief of Police

II. Resolutions



1. RESOLUTION 2011-483

Authorize Supervisor to Execute Dog Disposal Agreement with Town of Lancaster

Sponsored By: Councilmember Jaworowicz, Councilmember Swiatek

WHEREAS, the Town of Lancaster has requested that the Town of Cheektowaga renew its agreement with it for the proper disposal of dead dogs for the Town of Lancaster; and

WHEREAS, the Dog Control Officer has recommended that the Dog Disposal Agreement with Lancaster be renewed for another five (5) years at a cost of \$16.00 per dead dog; and

WHEREAS, a new agreement between the Town of Lancaster and the Town of Cheektowaga, for the period beginning September 1, 2011 for a period of five (5) years (ending August 31, 2016) has been prepared and is acceptable as to form by the Town Attorney's Office; and

WHEREAS, this Town Board, in an expression of inter-municipal cooperation, is willing to enter into this new agreement with the Town of Lancaster, NOW, THEREFORE, BE IT

RESOLVED, that the Supervisor be and hereby is authorized and directed to execute the attached Dog Disposal Agreement on behalf of the Town of Cheektowaga.

RESULT:	ADOPTED [UNANIMOUS]
MOVER:	Patricia Jaworowicz, Councilmember
SECONDER:	Jeff Swiatek, Councilmember
AYES:	Holtz, Jaworowicz, Swiatek, Rogowski, Zydel, Markel, Kaznowski



2. RESOLUTION 2011-484

Accept Storm Sewer Easement - Affinity Lane

Sponsored By: Councilmember Kaznowski, Councilmember Zydel

WHEREAS, the Town of Cheektowaga Engineering Department ("Town") is working on drainage improvements on Southgate Road to the north of property on Affinity Lane, owned by Ken-Vil Associates Limited Partnerships ("Owner"); and

WHEREAS, in order to install the proposed storm sewer system, it is necessary for the Town to have access to the property for the installation as well as future access for associated maintenance activities; and

WHEREAS, Ken-Vil Associates Limited Partnership has consented to grant the Town of Cheektowaga the necessary storm sewer drainage easement through its property; NOW, THEREFORE, BE IT

RESOLVED, that this Town Board hereby accepts said storm sewer drainage easement; and BE IT FURTHER

RESOLVED, that the Town Supervisor be and hereby is authorized and directed to execute this easement agreement and any and all other documents necessary to effectuate the granting of this easement on behalf of the Town of Cheektowaga.

RESULT:	ADOPTED [UNANIMOUS]
MOVER:	Stanley Kaznowski, Councilmember
SECONDER:	Richard Zydel, Councilmember
AYES:	Holtz, Jaworowicz, Swiatek, Rogowski, Zydel, Markel, Kaznowski



3. RESOLUTION 2011-485

Commitment to Participate in Update of County Hazard Mitigation Plan

Sponsored By: Supervisor Holtz, Councilmember Zydel

WHEREAS, the Town of Cheektowaga presently participates in a County-Wide All Hazard Mitigation Plan, and

WHEREAS, said County-Wide All Hazard Mitigation Plan needs to be updated, and

WHEREAS, the Town's Emergency Coordinator has met with representatives from the County of Erie and the Village of Sloan, and is recommending that the Town commit to participate in the development of an updated county-wide multi-jurisdictional hazard mitigation plan with the County of Erie and Village of Sloan, and

WHEREAS, this Board concurs with the recommendation from the Town Emergency Coordinator, NOW, THEREFORE, BE IT

RESOLVED, that this Town Board, on behalf of the Town of Cheektowaga, hereby commits to participate in the development of an updated county-wide multi-jurisdictional hazard mitigation plan with the County of Erie and Village of Sloan, and BE IT FURTHER

RESOLVED, that Emergency Coordinator Earl Loder and Town Engineer William Pugh be and hereby are authorized and directed to serve on the Multi-Jurisdictional Core Planning Group and to actively participate as requested throughout the planning process.

RESULT:	ADOPTED [UNANIMOUS]
MOVER:	Mary Holtz, Supervisor
SECONDER:	Richard Zydel, Councilmember
AYES:	Holtz, Jaworowicz, Swiatek, Rogowski, Zydel, Markel, Kaznowski

III. Adjournment

Motion by Supervisor Holtz; Seconded by Councilmember Rogowski to adjourn.

Alice Magierski, Town Clerk



Town of Cheektowaga

Regular Meeting

~ Minutes ~

3301 Broadway
Cheektowaga, NY 14227
<http://www.town.cheektowaga.ny.us>

Alice Magierski
716-686-3400

Tuesday, September, 6, 2011

6:45 PM

Council Chambers

I. Call to Order

6:45 PM Meeting called to order on September 6, 2011 at Council Chambers, 3301 Broadway St, Cheektowaga, NY.

Attendee Name	Organization	Title	Status	Arrived
Mary Holtz	Town of Cheektowaga	Supervisor	Present	
Patricia Jaworowicz	Town of Cheektowaga	Councilmember	Absent	
Jeff Swiatek	Town of Cheektowaga	Councilmember	Present	
James Rogowski	Town of Cheektowaga	Councilmember	Present	
Richard Zydel	Town of Cheektowaga	Councilmember	Present	
Charles Markel	Town of Cheektowaga	Councilmember	Present	
Stanley Kaznowski	Town of Cheektowaga	Councilmember	Present	

2. Additional Attendees

Thomas Adamczak, Supervising Building and Plumbing Inspector
 John Glascott, Captain - Police Department
 Brian Krause, Director of Finance and Administration
 William Pugh, Town Engineer
 Anthony Romano, Coordinator of Employee Relations
 Kevin Schenk, Town Attorney
 Mark Wegner, Highway Superintendent

II. Public Comment Period

III. Public Hearings

1. Special Use Permit (Drive Through) 3825 Union Road.

This being the time and place advertised for a Public Hearing, the Supervisor directed the Town Clerk to present that such notice has been duly published and posted; upon the order of the Supervisor such proof was duly filed.

The Supervisor announced that the Town Board would hear all persons interested in the subject of the hearing. Comments were heard, after which the Supervisor declared the hearing closed, decision was reserved.

RESULT: CLOSED [UNANIMOUS]
MOVER: Charles Markel, Councilmember
SECONDER: James Rogowski, Councilmember
AYES: Holtz, Swiatek, Rogowski, Zydel, Markel, Kaznowski

ABSENT: Patricia Jaworowicz

2. Unsafe Building at 29E Glenwood Court

RESULT: **CLOSED [UNANIMOUS]**
MOVER: Charles Markel, Councilmember
SECONDER: James Rogowski, Councilmember
AYES: Holtz, Swiatek, Rogowski, Zydel, Markel, Kaznowski
ABSENT: Patricia Jaworowicz

3. Unsafe Building at 44A Windwood Court

RESULT: **CLOSED [UNANIMOUS]**
MOVER: Charles Markel, Councilmember
SECONDER: James Rogowski, Councilmember
AYES: Holtz, Swiatek, Rogowski, Zydel, Markel, Kaznowski
ABSENT: Patricia Jaworowicz

4. Unsafe Building at 95 Huth Road

RESULT: **CLOSED [UNANIMOUS]**
MOVER: Charles Markel, Councilmember
SECONDER: James Rogowski, Councilmember
AYES: Holtz, Swiatek, Rogowski, Zydel, Markel, Kaznowski
ABSENT: Patricia Jaworowicz

5. Unsafe Building at 74 Hoerner Ave.

RESULT: **CLOSED [UNANIMOUS]**
MOVER: Charles Markel, Councilmember
SECONDER: James Rogowski, Councilmember
AYES: Holtz, Swiatek, Rogowski, Zydel, Markel, Kaznowski
ABSENT: Patricia Jaworowicz

6. Unsafe Building at 305 Hyland Road

RESULT: **CLOSED [UNANIMOUS]**
MOVER: Mary Holtz, Supervisor
SECONDER: Jeff Swiatek, Councilmember
AYES: Holtz, Swiatek, Rogowski, Zydel, Markel, Kaznowski
ABSENT: Patricia Jaworowicz

7. Unsafe Building at 3048 William Street

RESULT: **CLOSED [UNANIMOUS]**
MOVER: Mary Holtz, Supervisor
SECONDER: Jeff Swiatek, Councilmember
AYES: Holtz, Swiatek, Rogowski, Zydel, Markel, Kaznowski

ABSENT: Patricia Jaworowicz

8. Unsafe Building at 15 Atwood Place

RESULT: CLOSED [UNANIMOUS]
MOVER: Mary Holtz, Supervisor
SECONDER: Jeff Swiatek, Councilmember
AYES: Holtz, Swiatek, Rogowski, Zydel, Markel, Kaznowski
ABSENT: Patricia Jaworowicz

9. Unsafe Building at 1122 Walden Ave.

RESULT: CLOSED [UNANIMOUS]
MOVER: Mary Holtz, Supervisor
SECONDER: Jeff Swiatek, Councilmember
AYES: Holtz, Swiatek, Rogowski, Zydel, Markel, Kaznowski
ABSENT: Patricia Jaworowicz

IV. Resolutions



1. RESOLUTION 2011-486

Transfer of Funds

Sponsored By: Supervisor Holtz, Councilmember Swiatek

BE IT RESOLVED, that the following transfer is hereby approved and made a part hereof;

GENERAL FUND

FROM:	100.1910.2680	Insurance Recoveries	\$ 2,100.96
	100.1410.1255	Town Fees	250.00
	100.3120.1520	Police Misc. Revenues	30,872.70
	100.1910.2665	Sale of Equipment	13,055.00
	100.7110.2303	Over the Road Vehicles	50,000.00
	100.1355.2005	Office Equipment	1,500.00
TO:	100.1640.4447	Collision	2,100.96
	100.1410.4051	Records Management	250.00
	100.1680.2202	Network Hardware	30,872.70
	100.7110.2304	Park Equipment	13,055.00
	100.7110.2304	Park Equipment	50,000.00
	100.1355.4001	Office Supplies	1,500.00

HIGHWAY FUND

FROM:	300.1910.2665	Sale of Equipment	\$ 38,906.50
	300.1910.5031	Transfers In	37,230.00
TO:	300.5130.4462	Parts & Supplies	\$ 38,906.50
	300.5141.1902	Overtime Payroll	37,230.00

CAPITAL FUND

FROM:	500.5141.9910.5130	Highway Drainage	\$ 37,230.00
TO:	500.9950.9901.5130	Transfers Out	\$ 37,230.00

RESULT:	ADOPTED [UNANIMOUS]
MOVER:	Mary Holtz, Supervisor
SECONDER:	Jeff Swiatek, Councilmember
AYES:	Holtz, Swiatek, Rogowski, Zydel, Markel, Kaznowski
ABSENT:	Patricia Jaworowicz



2. RESOLUTION 2011-487

Warrant

Sponsored By: Supervisor Holtz, Councilmember Swiatek

BE IT RESOLVED, that the following Vouchers & Warrants submitted to the Town of Cheektowaga prior to September 2, 2011 are hereby approved and made a part hereof;

GENERAL FUND	\$ 3,083,004.72
RISK RETENTION FUND	128,208.07
DEBT SERVICE FUND	8,860,999.99
HUD HOUSING REHABILITATION	26,149.00
SPECIAL DISTRICTS FUND	725,276.64
HIGHWAY FUND	930,124.04
CAPITAL FUND	1,158,440.46
TRUST & AGENCY FUND	54,302.10
HUD CDBG FUND	7,412.66
PART TOWN FUND	138,673.11
NYS AFFORDABLE HOUSING	16,479.00
	<u>\$ 15,129,069.79</u>

RESULT:	ADOPTED [UNANIMOUS]
MOVER:	Mary Holtz, Supervisor
SECONDER:	Jeff Swiatek, Councilmember
AYES:	Holtz, Swiatek, Rogowski, Zydel, Markel, Kaznowski
ABSENT:	Patricia Jaworowicz



3. RESOLUTION 2011-488

Award of Bid - Four 2011 Ford Fusion Police Vehicles

Sponsored By: Councilmember Rogowski, Supervisor Holtz

WHEREAS, bids were duly received by the Town Clerk at a bid opening on August 24, 2011 for the purchase of Four (4) New and Unused 2011 Ford Fusion (or Equivalent) Police Vehicles by the Town of Cheektowaga Police Department, and said bids were referred to the Cheektowaga Police Department for analysis, tabulation and report; and

WHEREAS, such analysis, tabulation and report has been completed; NOW, THEREFORE BE IT

RESOLVED, that the bid is hereby awarded to Basil Ford, 1540 Walden Avenue, Cheektowaga, New York, 14225, for the purchase price of \$63,164.00, said bid being the lowest responsible bid meeting specifications; and BE IT FURTHER

RESOLVED, that funds for the purchase of these vehicles shall be appropriated from line item number 100-3120-2303.

RESULT:	ADOPTED [UNANIMOUS]
MOVER:	James Rogowski, Councilmember
SECONDER:	Mary Holtz, Supervisor
AYES:	Holtz, Swiatek, Rogowski, Zydell, Markel, Kaznowski
ABSENT:	Patricia Jaworowicz



4. RESOLUTION 2011-489

Amend Agreement with Quality Inspection Services for Police & Court Building Renovations and Addition

Sponsored By: Supervisor Holtz, Councilmember Swiatek

WHEREAS, by Town Board Resolution dated September 20, 2010, this Town Board engaged the firm of Quality Inspection Services, in an amount not to exceed \$38,386.00, to perform special inspections during construction of the Police and Court Building Renovations and Addition Project, as dictated by the New York State Division of Code Enforcement and Administration Regulations, AND

WHEREAS, building construction inspections are required to be conducted beyond the estimated manhours provided for in the original professional services agreement, NOW, THEREFORE, BE IT

RESOLVED, that the professional services agreement with Quality Inspection Services, Inc., 37 Franklin Street, Suite 400, Buffalo, New York 14202 be and hereby is amended to allocate an increase in the agreement not to exceed \$15,000 for conducting remaining special inspections required to be conducted throughout the balance of the construction project, AND, BE IT FURTHER

RESOLVED, that funding for additional professional services shall be chargeable to Account #500-1910-9399-5025.

RESULT:	ADOPTED [UNANIMOUS]
MOVER:	Mary Holtz, Supervisor
SECONDER:	Jeff Swiatek, Councilmember
AYES:	Holtz, Swiatek, Rogowski, Zydell, Markel, Kaznowski
ABSENT:	Patricia Jaworowicz



5. RESOLUTION 2011-490

Amend Change Order Resolution for Demolition of 1112 Walden Avenue

Sponsored By: Councilmember Markel, Councilmember Kaznowski

WHEREAS, by resolution dated August 15, 2011 (Resolution 2011-481), this Town Board approved Change Order No. 1 for the contract for the demolition of the structures at 1112 Walden Avenue; and

WHEREAS, in addition to the removal of the additional asbestos set forth in said Resolution, the Contractor removed 100 tires found on the premises, at a cost of \$400.00, which additional work was not part of the demolition bid specifications; and

WHEREAS, through inadvertence and oversight, said item and amount was not stated in Resolution 2011-481; NOW, THEREFORE, BE IT

RESOLVED, that Resolution 2011-481 be amended to read as follows:

"WHEREAS, the contract for the demolition of property located at 1112 Walden Avenue was awarded to Hannah Demolition, Inc., by resolution dated April 18, 2011 (Resolution 2011-215) for the contract amount of \$18,200.00; and

WHEREAS, subsequent to said bid award, the Town was notified that there was an additional 850 square feet of asbestos tile hidden under a newer flooring and subflooring in the structure, as well as the finding of 100 tires on the premises, and both items were not part of the bid specifications; and

WHEREAS, the removal of said asbestos material will cost an additional \$4,200.00, and the removal of said tires will cost an additional \$400.00; and

WHEREAS, the Town's Consulting Engineers, Nussbaumer & Clarke, Inc., recommend the approval of Change Order No. 1 (final) which provides for contract modifications for the removal of the additional asbestos materials and tires at 1112 Walden Avenue; NOW, THEREFORE, BE IT

RESOLVED, that this Town Board hereby accepts the revised project and directs the Supervisor to execute the necessary Change Order No. 1 document with Hannah Demolition, Inc., which provides for an increase to the aforesaid contract in the amount of \$4,600.00, which shall be chargeable to budget line item number 800-0800-0440."

RESULT:	ADOPTED [UNANIMOUS]
MOVER:	Charles Markel, Councilmember
SECONDER:	Stanley Kaznowski, Councilmember
AYES:	Holtz, Swiatek, Rogowski, Zydel, Markel, Kaznowski
ABSENT:	Patricia Jaworowicz



6. RESOLUTION 2011-491

Call for Public Hearing - Landlord Licensing Law

Sponsored By: Supervisor Holtz, Councilmember Kaznowski

WHEREAS, the rental of residential dwellings is a business, and

WHEREAS, residential rental properties may become a haven for criminal and other disruptive activities which impact other property owners in our neighborhoods, and

WHEREAS, this Town Board, under the Town Law of the State of New York, is authorized to regulate and licenses businesses within the Town of Cheektowaga, and

WHEREAS, this Town Board is interested in licensing the rental of residential dwelling units within the Town in order to control the adverse effects caused by tenants who engage in illegal activities, and

WHEREAS, a Landlord Licensing Law has been drafted to accomplish this purpose, NOW, THEREFORE, BE IT

RESOLVED, that, in accordance with the provisions of the Town Law/Municipal Home Rule Law of the State of New York, a public hearing shall be held on the 19th day of September, 2011 at 6:45 P.M. at a meeting of the Town Board at the Cheektowaga Town Hall, 3301 Broadway, Cheektowaga, New York; at which hearing all interested parties will be given an opportunity to be heard and at which time and place it may be determined by the Town Board whether Local Law Intro No. 2011-2 of the Year 2011, entitled "A Local Law Relating to Landlord Licensing" should be enacted, and BE IT FURTHER

RESOLVED, that the Town Clerk shall publish the attached Notice of Hearing in the CHEEKTOWAGA BEE, the official Town newspaper.

LEGAL NOTICE

NOTICE IS HEREBY GIVEN that a public hearing will be held by the Town Board of the Town of Cheektowaga, Erie County, New York at the Town Hall, 3301 Broadway, Cheektowaga, New York, on the 19th day of September, 2011 at 6:45 P.M. on said day for the purpose of considering the adoption of Local Law Intro No. 2011-2 of the Year 2011, entitled "A Local Law Relating to Landlord Licensing". A summary of such Local Law is as follows:

LOCAL LAW INTRO NO. 2011-2 OF THE YEAR 2011

A LOCAL LAW RELATING TO LANDLORD LICENSING

The purpose of this law is to require owners of residential rental properties to obtain a rental housing business license from the Town of Cheektowaga in order to lease their

properties. In the event there are police reports issued for criminal or public nuisance activities at the dwelling units, the property owner would be notified to take corrective action; if the property owner does not effect corrective action at his property and criminal or public nuisance activity continues at the dwelling unit, the owner would be fined by the Town.

A copy of the entire text of Local Law Intro No. 2011-2 is on file in the Town Clerk's Office, where the same may be viewed during regular business hours

BY ORDER OF THE TOWN BOARD OF THE TOWN OF CHEEKTOWAGA, ERIE COUNTY, NEW YORK.

Dated: September 6, 2011

ALICE MAGIERSKI
Town Clerk

Attachments:

LANDLORD LICENSING LAW rev 8-31 (DOC)

RESULT: ADOPTED [UNANIMOUS]
MOVER: Mary Holtz, Supervisor
SECONDER: Stanley Kaznowski, Councilmember
AYES: Holtz, Swiatek, Rogowski, Zydel, Markel, Kaznowski
ABSENT: Patricia Jaworowicz



7. RESOLUTION 2011-492

Proclaim September, 2011 "National Preparedness Month"

Sponsored By: Supervisor Holtz, Councilmember Swiatek

WHEREAS, "National Preparedness Month" creates an important opportunity for every resident of the Town of Cheektowaga to prepare their homes, businesses, and communities for any type of emergency, including natural disasters and potential terrorist attacks; and

WHEREAS, investing in the preparedness of ourselves, our families, businesses, and communities can reduce fatalities and economic devastation in our community and in our nation; and

WHEREAS, the Federal Emergency Management Agency's *Ready* Campaign, Citizen Corps and other federal, state, local, tribal, territorial, private, and volunteer agencies, are working to increase public activities in preparing for emergencies and to educate individuals on how to take action; and

WHEREAS, emergency preparedness is the responsibility of every citizen of our Town, and all citizens are urged to make preparedness a priority and work together, as a team, to ensure that individuals, families, and our community are prepared for disasters and emergencies of any type; and

WHEREAS, all citizens of the Town of Cheektowaga are encouraged to participate in citizen preparedness activities and asked to review the *Ready* Campaign's websites at Ready.gov. or Listo.gov. and become more prepared; NOW, THEREFORE, BE IT

RESOLVED, that the Town Board of the Town of Cheektowaga hereby proclaims September, 2011 as "National Preparedness Month," and encourages all citizens and businesses to develop their own emergency preparedness plan, and work together toward creating a more prepared society.

RESULT:	ADOPTED [UNANIMOUS]
MOVER:	Mary Holtz, Supervisor
SECONDER:	Jeff Swiatek, Councilmember
AYES:	Holtz, Swiatek, Rogowski, Zydel, Markel, Kaznowski
ABSENT:	Patricia Jaworowicz



8. RESOLUTION 2011-493

Authorize Supervisor to Sign Dasherboard Contracts

Sponsored By: Councilmember Zydel, Councilmember Rogowski

BE IT RESOLVED that subject to approval by the Town Attorney, Supervisor Mary F. Holtz be and hereby is authorized to sign contracts between the Town of Cheektowaga, businesses and/or organizations for dasherboard advertising and ice rentals at the Town Recreation Center during the 2011-2012 season.

FUNDING SOURCE: 0100.7140.4521

REVENUE SOURCE 0100.7140.2128
0100.0882

RESULT:	ADOPTED [UNANIMOUS]
MOVER:	Richard Zydel, Councilmember
SECONDER:	James Rogowski, Councilmember
AYES:	Holtz, Swiatek, Rogowski, Zydel, Markel, Kaznowski
ABSENT:	Patricia Jaworowicz



9. RESOLUTION 2011-494

Authorize Supervisor to Execute Grant Application for License Plate Reader

Sponsored By: Councilmember Rogowski, Supervisor Holtz

WHEREAS, grant monies are available through the Target Headquarters Public Safety Grants program to help support the safety and preparedness of the communities where their guests and team members live and work; and

WHEREAS, the Cheektowaga Police Department is in need of a License Plate Reader estimated to cost \$18,310 including licensing and installation; and

WHEREAS, acquisition of a License Plate Reader will help reduce overall crime in the community by improving apprehension of persons wanted for various violations and crimes, NOW, THEREFORE, BE IT

RESOLVED, that Grantmakers Advantage, Inc., the Town's grant consultants, be authorized and directed to complete the necessary application, forms, etc. to be submitted to Target for the purpose of securing a grant in the amount of \$5,000; and BE IT FURTHER

RESOLVED, additional monies necessary to purchase the License Plate Reader are available from budget line number 600-0600-0881; and BE IT FURTHER

RESOLVED, that the Supervisor and Chief of Police be and hereby are authorized and directed to execute all documents pertaining to the application and acquisition of said funding.

RESULT:	ADOPTED [UNANIMOUS]
MOVER:	James Rogowski, Councilmember
SECONDER:	Mary Holtz, Supervisor
AYES:	Holtz, Swiatek, Rogowski, Zydell, Markel, Kaznowski
ABSENT:	Patricia Jaworowicz



10. RESOLUTION 2011-495

Authorize Supervisor to Execute Subrecipient Agreements with Villages of Depew and Sloan

Sponsored By: Councilmember Markel, Councilmember Kaznowski

WHEREAS, the Town of Cheektowaga receives Community Development Block Grant funds from the Department of Housing and Community Development, and

WHEREAS, federal regulations require the Town to execute subrecipient agreements with those entities receiving Community Development Block Grant funds through the Town, and

WHEREAS, Community Development Block Grant funds have been allocated in the 2011 program year budgets for the Villages of Depew and Sloan, NOW, THEREFORE, BE IT

RESOLVED, that the Supervisor be and hereby is authorized to execute Subrecipient Agreements for Community Development Block Grant funding with the Villages of Depew and Sloan for the 2011 Community Development Block Grant program year.

RESULT:	ADOPTED [UNANIMOUS]
MOVER:	Charles Markel, Councilmember
SECONDER:	Stanley Kaznowski, Councilmember
AYES:	Holtz, Swiatek, Rogowski, Zydell, Markel, Kaznowski
ABSENT:	Patricia Jaworowicz



11. RESOLUTION 2011-496

Special Event - Cleveland Hill High School Homecoming Parade

Sponsored By: Councilmember Rogowski, Councilmember Zydel

WHEREAS, by resolution dated May 1, 1995, this Town Board adopted a Special Events policy, which requires anyone wishing to hold a special event in the Town to file an application and supporting documentation, fees, etc. to the Town Clerk prior to the special event, and

WHEREAS, Cleveland Hill PTSA has made application to hold a Homecoming Parade on Saturday, October 15, 2011, beginning at 12:00 p.m. (parade route to be provided to the Police Department); and

WHEREAS, this Board has reviewed the aforementioned application, which application has been approved by the Cheektowaga Police Department, and has no objection to same, and

WHEREAS, due to the nature of the event, this Town Board hereby waives the following requirements: Submittal of plan for sanitary facilities;

- 1) Submittal of site plan;
- 2) Requirement that application be made at least 60 days prior to the date of the special event;
- 3) Submittal of Security Plan;
- 4) Submittal of Fire Prevention/Emergency Services Plan.

NOW, THEREFORE, BE IT

RESOLVED, that this Town Board hereby approves the aforementioned application of Cleveland Hill PTSA for the aforementioned parade to be held on Saturday, October 15, 2011, and BE IT FURTHER

RESOLVED, that the Chief of Police be and hereby is directed to provide traffic safety and escort services for such parade and to ensure compliance with Section 1660 (a)(6) of the Vehicle and Traffic Law.

RESULT:	ADOPTED [UNANIMOUS]
MOVER:	James Rogowski, Councilmember
SECONDER:	Richard Zydel, Councilmember
AYES:	Holtz, Swiatek, Rogowski, Zydel, Markel, Kaznowski
ABSENT:	Patricia Jaworowicz



12. RESOLUTION 2011-497

Bonfire-Cheektowaga Central/3600 Union Road

Sponsored By: Councilmember Markel, Councilmember Zydel

WHEREAS, pursuant to the Open Burning Law of the Town of Cheektowaga, the Fire Inspector reviews various applications for open fires and open burning and renders his recommendation concerning the fire safety and impact to the general public of such application, AND

WHEREAS, the Town Board, pursuant to the Open Burning Law of the Town of Cheektowaga, is designated the Approval Agency, AND

WHEREAS, since the Town Board is the Approval Agency, it must affirm, modify or reject any recommendations or permits submitted to it by the Town Fire Inspector, AND

WHEREAS, an application for a permit was submitted by Cheektowaga Central High School to conduct a open fire on September 20, 2011, rain date of September 21, 2011 on the property located at 3600 Union Road, Cheektowaga, New York AND

WHEREAS, the applicant intends to maintain a small bonfire with the assistance of the Forks Fire Department in conjunction with summer youth activities, AND

WHEREAS, the Fire Inspector has received this application and finds that all requirements have been met. And that this application is in compliance with conditions and requirement of the Town of Cheektowaga Fire Prevention Code and the Open Burning Law. He requests the Town Board approve issuance of a permit, AND

WHEREAS, this Town Board has reviewed the application submitted by the Cheektowaga Central High School and the recommendations of the Fire Inspector, NOW, THEREFORE, BE IT

RESOLVED, that this Town Board, authorizes the Fire Inspector to issue such permit.

RESULT:	ADOPTED [UNANIMOUS]
MOVER:	Charles Markel, Councilmember
SECONDER:	Richard Zydel, Councilmember
AYES:	Holtz, Swiatek, Rogowski, Zydel, Markel, Kaznowski
ABSENT:	Patricia Jaworowicz



13. RESOLUTION 2011-498

Bonfire-JFK High School/305 Cayuga Creek Road

Sponsored By: Councilmember Markel, Councilmember Zydel

WHEREAS, pursuant to the Open Burning Law of the Town of Cheektowaga, the Fire Inspector reviews various applications for open fires and open burning and renders his recommendation concerning the fire safety and impact to the general public of such application, AND

WHEREAS, the Town Board, pursuant to the Open Burning Law of the Town of Cheektowaga, is designated the Approval Agency, AND

WHEREAS, since the Town Board is the Approval Agency, it must affirm, modify or reject any recommendations or permits submitted to it by the Town Fire Inspector, AND

WHEREAS, an application for a permit was submitted by John F. Kennedy High School to conduct a open fire on September 16, 2011 on the property located at 305 Cayuga Creek Road, Cheektowaga, New York AND

WHEREAS, the applicant intends to maintain a small bonfire with the assistance of the Doyle 1 and Doyle 2 Fire Department in conjunction with summer youth activities, AND

WHEREAS, the Fire Inspector has received this application and finds that all requirements have been met. And that this application is in compliance with conditions and requirement of the Town of Cheektowaga Fire Prevention Code and the Open Burning Law. He requests the Town Board approve issuance of a permit, AND

WHEREAS, this Town Board has reviewed the application submitted by the John F. Kennedy High School and the recommendations of the Fire Inspector, NOW, THEREFORE, BE IT

RESOLVED, that this Town Board, authorizes the Fire Inspector to issue such permit.

RESULT:	ADOPTED [UNANIMOUS]
MOVER:	Charles Markel, Councilmember
SECONDER:	Richard Zydel, Councilmember
AYES:	Holtz, Swiatek, Rogowski, Zydel, Markel, Kaznowski
ABSENT:	Patricia Jaworowicz



14. RESOLUTION 2011-499

Negative SEQR Declaration- Southgate & S. Century Roads Storm Sewer Project

Sponsored By: Councilmember Kaznowski, Supervisor Holtz

WHEREAS, pursuant to the Environmental Impact Review Ordinance of the Town of Cheektowaga, the Environmental Advisory Committee ("EAC") reviews various applications for site plans, rezonings, special permits, etc. and renders its recommendation concerning the environmental significance of such application, AND

WHEREAS, the Town Board, pursuant to the Environmental Impact Review Ordinance of the Town of Cheektowaga, is designated the Lead Agency in most instances, AND

WHEREAS, since the Town Board is the Lead Agency, it must affirm, modify or reject any recommendations submitted to it by the Advisory Committee, AND

WHEREAS, an application was submitted by The Town of Cheektowaga Engineering Department for the construction of a storm sewer trunk line to provide additional storm drainage capacity for existing storm sewers within the Southgate Road and South Century Road areas of the Town, AND

WHEREAS, the Environmental Advisory Committee at its meetings held on August 3, 2011 recommended a determination of non-significance, AND

WHEREAS, this Town Board has reviewed the application submitted and the recommendations made by the Environmental Advisory Committee NOW, THEREFORE, BE IT

RESOLVED, that this Town Board determines that the project will not have a significant effect on the environment and therefore issues a Negative Declaration for purposes of SEQRA.

RESULT:	ADOPTED [UNANIMOUS]
MOVER:	Stanley Kaznowski, Councilmember
SECONDER:	Mary Holtz, Supervisor
AYES:	Holtz, Swiatek, Rogowski, Zydel, Markel, Kaznowski
ABSENT:	Patricia Jaworowicz



15. RESOLUTION 2011-500

Accept Easement and Maintenance Agreement for 3828 Broadway

Sponsored By: Councilmember Kaznowski, Councilmember Zydel

WHEREAS, as part of the project for the rezoning and development of property at 3828 Broadway, the Town of Cheektowaga requested a storm sewer easement from Penske Truck Leasing Co., L.P., and

WHEREAS, a storm sewer easement for 3828 Broadway has been signed and submitted to the Town for its approval, and

WHEREAS, the developer has also submitted a Stormwater Control Facility Maintenance Agreement as per Chapter 209 of the Code of the Town of Cheektowaga, and

WHEREAS, the Town Engineer and Town Attorney's Office have reviewed these documents and have recommended that the Town accept same, NOW, THEREFORE, BE IT

RESOLVED, that this Town Board hereby accepts the above referenced easement and agreement, and BE IT FURTHER

RESOLVED, that the Supervisor be and hereby is authorized and directed to execute such documents on behalf of the Town, and BE IT FURTHER

RESOLVED, that the Town Attorney's Office be and hereby is directed to arrange for the filing of such documents in the Erie County Clerk's Office.

RESULT:	ADOPTED [UNANIMOUS]
MOVER:	Stanley Kaznowski, Councilmember
SECONDER:	Richard Zydel, Councilmember
AYES:	Holtz, Swiatek, Rogowski, Zydel, Markel, Kaznowski
ABSENT:	Patricia Jaworowicz



16. RESOLUTION 2011-501

Cleveland Hill Usage of Town Park

Sponsored By: Councilmember Rogowski, Councilmember Zydel

WHEREAS, The Cleveland Hill Union Free School District has requested permission to utilize a portion of Cheektowaga Town Park from September 7, 2011 to October 18, 2011 for practices and for its home cross-county track team meets, and

WHEREAS, the General Crew Chief of the Facilities Department has reviewed such request and has no objection to same, and

WHEREAS, the Cleveland Hill Union Free School District has provided the Town with the necessary insurance coverage for such track meets, and

WHEREAS, Cleveland Hill Union Free School District shall be responsible to utilize individuals to provide traffic control to monitor students crossing the roadways for their track meets and practices, and

WHEREAS, this Town Board, in the spirit of cooperation, wishes to approve this request, NOW, THEREFORE, BE IT

RESOLVED, that this Town Board hereby approve the use of Cheektowaga Town Park from September 7, 2011 to October 18, 2011 for the Cleveland Hill Cross Country Track team practices, and BE IT FURTHER

RESOLVED, that the Director of Athletics of the Cleveland Hill School shall coordinate with the General Crew Chief of the Facilities Department concerning these track meets.

RESULT:	ADOPTED [UNANIMOUS]
MOVER:	James Rogowski, Councilmember
SECONDER:	Richard Zydel, Councilmember
AYES:	Holtz, Swiatek, Rogowski, Zydel, Markel, Kaznowski
ABSENT:	Patricia Jaworowicz



17. RESOLUTION 2011-502

Hiring/Termination of Part-Time/Seasonal Employees

Sponsored By: Councilmember Swiatek, Supervisor Holtz

BE IT RESOLVED, that the following individuals be and hereby are hired as **SEASONAL EMPLOYEES**, not to exceed five (5) months in a calendar year, in the various departments listed and in compliance with Civil Service Laws and Regulations as well as the provisions of the Town's collective bargaining agreement between the Town of Cheektowaga and the Town of Cheektowaga Employees Association:

SEWER MAINTENANCE Laborer \$8.00/hour effective 9/7/11
Kevin T. Fischer, Cheektowaga, New York
Austin J. Bobeck, Cheektowaga, New York

BE IT RESOLVED, that the following individuals be and hereby are hired as **PART-TIME EMPLOYEES** in the departments listed, not to exceed nineteen (19) hours on a weekly basis, in compliance with Civil Service Laws and Regulations as well as the provisions of the Town's collective bargaining agreement between the Town of Cheektowaga and the Town of Cheektowaga Employees Association:

POLICE DEPARTMENT Clerk \$7.25/hour effective 9/6/11
Keileigh C. Pecyne, Cheektowaga, New York

POLICE DEPARTMENT School Crossing Guard (Substitute) \$8.50/hour effective 9/1/11
John F. Drennen, Cheektowaga, New York

RECORDS CENTER Clerk \$9.50/hour effective 9/7/11
Joseph S. Fedyna, Cheektowaga, New York

RECORDS CENTER Clerk \$8.25/hour effective 9/7/11
Melissa A. Dabb, Cheektowaga, New York

BE IT RESOLVED, that the following seasonal and/or part-time employees be and hereby are terminated as listed:

FACILITIES DEPARTMENT
Raymond Arne effective 8/12/11 (Laborer)
Thomas Somogye effective 8/17/11 (Laborer)

SEWER MAINTENANCE
Jacob Nowak effective 9/7/11 (Laborer)
Nicholas Kotarski effective 9/7/11 (Laborer)
Shane Latshaw effective 9/7/11 (Laborer)

JUSTICE COURT
Daniel Clifford effective 8/8/11 (Court Officer)

POLICE DEPARTMENT
Melissa Gerace effective 8/21/11 (Clerk)

Motion by Councilmember Markel; Seconded by Supervisor Holtz; to waive the reading of names for this resolution. Motion Carried.

RESULT: **ADOPTED [UNANIMOUS]**
MOVER: Jeff Swiatek, Councilmember
SECONDER: Mary Holtz, Supervisor
AYES: Holtz, Swiatek, Rogowski, Zydel, Markel, Kaznowski
ABSENT: Patricia Jaworowicz



18. RESOLUTION 2011-503

Termination of Laborer

Sponsored By: Councilmember Swiatek, Supervisor Holtz

BE IT RESOLVED, James P. Kelly, a Laborer in the Highway Department, be and hereby is terminated effective August 24, 2011.

RESULT:	ADOPTED [UNANIMOUS]
MOVER:	Jeff Swiatek, Councilmember
SECONDER:	Mary Holtz, Supervisor
AYES:	Holtz, Swiatek, Rogowski, Zydel, Markel, Kaznowski
ABSENT:	Patricia Jaworowicz

**19. RESOLUTION 2011-504****Transfer Court Clerk (FT/Temp) to Clerk Typist PT/Jill Baszczynski/Justice Court**

Sponsored By: Councilmember Swiatek, Supervisor Holtz

BE IT RESOLVED, that Jill Baszczynski of Cheektowaga, New York be and hereby is transferred from the position of temporary Court Clerk to part-time Clerk Typist at a salary of \$16.644 per hour in the Justice Court effective September 6, 2011.

RESULT:	ADOPTED [UNANIMOUS]
MOVER:	Jeff Swiatek, Councilmember
SECONDER:	Mary Holtz, Supervisor
AYES:	Holtz, Swiatek, Rogowski, Zydel, Markel, Kaznowski
ABSENT:	Patricia Jaworowicz



20. RESOLUTION 2011-505

Appointment of Clerk Typist (Competitive/Permanent) Mary Lynn Barnhard/Sewer Department

Sponsored By: Councilmember Swiatek, Supervisor Holtz

WHEREAS, a vacancy exists in the title of Clerk Typist in the Sewer Maintenance Department; AND

WHEREAS, notice of said vacancy has been posted in accordance with the provisions of the Town's collective bargaining agreement with the Town of Cheektowaga Employees Association; AND

WHEREAS, no full-time employee bid on said vacancy; AND

WHEREAS, said title falls under the competitive class of Erie County Civil Service; AND

WHEREAS, a current civil service list exists for said title; AND

WHEREAS, said civil service list was canvassed and interviews conducted; AND

WHEREAS, Mary Lynn Barnhard appears on said list and meets all the necessary qualifications for appointment; NOW, THEREFORE, BE IT

RESOLVED, Mary Lynn Barnhard of Cheektowaga, New York, be and hereby is appointed to the position of Clerk Typist in the Sewer Maintenance Department in accordance with the terms and conditions of the Town's collective bargaining agreement with the Town of Cheektowaga Employees Association effective September 26, 2011.

RESULT:	ADOPTED [UNANIMOUS]
MOVER:	Jeff Swiatek, Councilmember
SECONDER:	Mary Holtz, Supervisor
AYES:	Holtz, Swiatek, Rogowski, Zydel, Markel, Kaznowski
ABSENT:	Patricia Jaworowicz



21. RESOLUTION 2011-506

Appointment of Automotive Mechanic Helper (Non-Competitive/Permanent) Mitchell A. Polanski/Highway Department

Sponsored By: Councilmember Swiatek, Supervisor Holtz

WHEREAS, a vacancy exists in the title of Automotive Mechanic Helper in the Highway Department; AND

WHEREAS, notice of such vacancy has been posted in accordance with the provisions of the Town's collective bargaining agreement with the Town of Cheektowaga Employees Association; AND

WHEREAS, no full-time bargaining unit member bid on said vacancy; AND

WHEREAS, Mitchell A. Polanski, currently employed as a temporary Automotive Mechanic in the Highway Department, applied for said vacancy and meets the qualifications for appointment; NOW, THEREFORE, BE IT

RESOLVED, that Mitchell A. Polanski of Depew, New York, be and hereby is appointed to the position of Automotive Mechanic Helper in the Highway Department in accordance with the terms and conditions of the Town's collective bargaining agreement with the Town of Cheektowaga Employees Association effective August 26, 2011.

RESULT:	ADOPTED [UNANIMOUS]
MOVER:	Jeff Swiatek, Councilmember
SECONDER:	Mary Holtz, Supervisor
AYES:	Holtz, Swiatek, Rogowski, Zydel, Markel, Kaznowski
ABSENT:	Patricia Jaworowicz



22. RESOLUTION 2011-507

Appointment of Motor Equipment Operator - B (Non-Competitive/Permanent) Douglas H. Konczal/Highway Department

Sponsored By: Councilmember Swiatek, Supervisor Holtz

WHEREAS, a vacancy exists in the title of Motor Equipment Operator - B in the Highway Department; AND

WHEREAS, the Town of Cheektowaga Employees Association has agreed to waive the posting of said vacancy; AND

WHEREAS, the Highway Department was canvassed internally in accordance with an agreement with the Town of Cheektowaga Employees Association; AND

WHEREAS, Douglas H. Konczal, currently employed as a temporary Motor Equipment Operator - B in the Highway Department, bid on said vacancy and meets the qualifications for appointment; NOW, THEREFORE, BE IT

RESOLVED, that Douglas H. Konczal of Cheektowaga, New York, be and hereby is appointed to the position of Motor Equipment Operator - B in the Highway Department in accordance with the terms and conditions of the Town's collective bargaining agreement with the Town of Cheektowaga Employees Association effective August 10, 2011.

RESULT:	ADOPTED [UNANIMOUS]
MOVER:	Jeff Swiatek, Councilmember
SECONDER:	Mary Holtz, Supervisor
AYES:	Holtz, Swiatek, Rogowski, Zydel, Markel, Kaznowski
ABSENT:	Patricia Jaworowicz



23. RESOLUTION 2011-508

Appointment of Senior Sewer Maintenance Worker (Non-Competitive/Permanent) Scott Zaranek/Sewer Department

Sponsored By: Councilmember Swiatek, Supervisor Holtz

WHEREAS, Scott M. Zaranek was appointed by this Town Board to the position of Sewer Maintenance Worker effective March 9, 2010; AND

WHEREAS, Mr. Zaranek has successfully completed eighteen (18) months in the title and is eligible to be promoted to the position of Senior Sewer Maintenance Worker; NOW, THEREFORE, BE IT

RESOLVED, that Scott M. Zaranek of Cheektowaga, New York be and hereby is appointed to the position of Senior Sewer Maintenance Worker in the Sewer Maintenance Division under the terms and conditions of the bargaining agreement between the Town and the Town of Cheektowaga Employees Association effective September 9, 2011.

RESULT:	ADOPTED [UNANIMOUS]
MOVER:	Jeff Swiatek, Councilmember
SECONDER:	Mary Holtz, Supervisor
AYES:	Holtz, Swiatek, Rogowski, Zydel, Markel, Kaznowski
ABSENT:	Patricia Jaworowicz

**24. RESOLUTION 2011-509****Amendment of Travel Authorization/Building and Plumbing Department/Fire Inspector Robert Jaroszewski**

Sponsored By: Councilmember Swiatek, Supervisor Holtz

WHEREAS, at the Town Board Meeting of June 6, 2011, Fire Inspector Robert Jaroszewski was approved to attend the "New York State Fire Marshalls and Inspectors Educational Conference," being held September 29 - 30, 2011 in Skaneateles, New York; AND

WHEREAS, the dates approved for attendance must be amended to September 27-29, 2011; NOW, THEREFORE, BE IT

RESOLVED, that Fire Inspector Robert Jaroszewski be and hereby is authorized to attend the "New York State Fire Marshalls and Inspectors Educational Conference," being held September 27 - 29, 2011 in Skaneateles, New York.

RESULT:	ADOPTED [UNANIMOUS]
MOVER:	Jeff Swiatek, Councilmember
SECONDER:	Mary Holtz, Supervisor
AYES:	Holtz, Swiatek, Rogowski, Zydel, Markel, Kaznowski
ABSENT:	Patricia Jaworowicz



25. RESOLUTION 2011-510

Travel Authorization Police Department

Sponsored By: Councilmember Swiatek, Councilmember Rogowski

WHEREAS, the "Bloodstain Pattern Analysis Course" is being held from September 26 through September 30, 2011 in Cheektowaga, New York; AND

WHEREAS, the following individuals have requested authorization to attend said school:

- Captain Michael Isbrandt
- Detective David Mossman
- Detective Paul Batt
- Detective Valentine Zimniewicz
- Detective Christopher Chojnacki
- Detective James Genson; AND

WHEREAS, Police Chief David Zack has submitted a request for travel authorization along with the proper paperwork in a timely manner; AND

WHEREAS, the total cost to the Town shall not exceed \$1,200; NOW, THEREFORE, BE IT

RESOLVED, that the aforementioned individuals be and hereby are authorized to attend the "Bloodstain Pattern Analysis Course" being held from September 26 through September 30, 2011 in Cheektowaga, New York.

RESULT:	ADOPTED [UNANIMOUS]
MOVER:	Jeff Swiatek, Councilmember
SECONDER:	James Rogowski, Councilmember
AYES:	Holtz, Swiatek, Rogowski, Zydel, Markel, Kaznowski
ABSENT:	Patricia Jaworowicz

**26. RESOLUTION 2011-511****Travel Authorization Police Department/Detective Timothy Szymanski**

Sponsored By: Councilmember Swiatek, Councilmember Rogowski

WHEREAS, a "Crime Scene Processing Workshop" is being held from November 14 through November 18, 2011 in Jacksonville, Florida; AND

WHEREAS, Detective Timothy Szymanski has requested authorization to attend said workshop;

WHEREAS, Police Chief David Zack has submitted a request for travel authorization along with the proper paperwork in a timely manner; AND

WHEREAS, the total cost to the Town shall not exceed \$2,065; NOW, THEREFORE, BE IT

RESOLVED, that Detective Timothy Szymanski be and hereby is authorized to attend the "Crime Scene Processing Workshop" being held from November 14 through November 18, 2011 in Jacksonville, Florida.

RESULT:	ADOPTED [UNANIMOUS]
MOVER:	Jeff Swiatek, Councilmember
SECONDER:	James Rogowski, Councilmember
AYES:	Holtz, Swiatek, Rogowski, Zydell, Markel, Kaznowski
ABSENT:	Patricia Jaworowicz



27. RESOLUTION 2011-512

Travel Authorization Police Department/Lieutenant Thomas Gerace

Sponsored By: Councilmember Swiatek, Councilmember Rogowski

WHEREAS, the “24th Annual Colonel Henry F. Williams International Homicide Seminar” is being held from September 17 through September 22, 2011 in Albany, New York; AND

WHEREAS, Lieutenant Thomas Gerace has requested authorization to attend said workshop;

WHEREAS, Police Chief David Zack has submitted a request for travel authorization along with the proper paperwork in a timely manner; AND

WHEREAS, the total cost to the Town shall not exceed \$860; NOW, THEREFORE, BE IT

RESOLVED, that Lieutenant Thomas Gerace be and hereby is authorized to attend the “24th Annual Colonel Henry F. Williams International Homicide Seminar” being held from September 17 through September 22, 2011 in Albany, New York.

RESULT:	ADOPTED [UNANIMOUS]
MOVER:	Jeff Swiatek, Councilmember
SECONDER:	James Rogowski, Councilmember
AYES:	Holtz, Swiatek, Rogowski, Zydel, Markel, Kaznowski
ABSENT:	Patricia Jaworowicz

V. Communications

A. Departmental Communications

1. Supervisor Statement of Funds - July 2011
2. Building Permit List - August 2011
3. Minutes: Cheektowaga Traffic Safety Commission - July 19, 2011
4. Minutes: Cheektowaga Conservation Advisory Council - August 4, 2011
5. Minutes: Cheektowaga Planning Board - August 11, 2011

B. General Communications

1. Summons & Complaint: CTS Contracting Inc. F/K/A Custom Topsoil Inc. Vs. Town of Cheektowaga

2. Notice of Claim: Jonathan Berg Vs. Town of Cheektowaga
3. Notice of Claim: Angela Burnley Vs. Town of Cheektowaga
4. Notice of Claim: GEICO Aso Stephen Vujcec Vs. Town of Cheektowaga
5. Notice of Claim: Dana Musso Vs. Town of Cheektowaga
6. Notice of Claim: Jenine Nati, Individually and as Parent and NG of Leena Staubitz Vs. Town of Cheektowaga
7. Notice of Claim: Charles & Ann Marie Siraguse Vs. Town of Cheektowaga
8. Notice of Claim: Brianna Vujcec Vs. Town of Cheektowaga

VI. Comments

A. Supervisor's Comments

B. Councilmember's Comments

C. Public Comments

VII. Adjournment

Motion by Supervisor Holtz; Seconded by Councilmember Zydel to adjourn the meeting at 8:07 PM and a moment of silence in Memory of 9/11.

Alice Magierski, Town Clerk

LANDLORD LICENSING LAW

Section 1. Purpose

The Town of Cheektowaga hereby finds and declares that the rental of dwelling units constitutes a business which impacts upon the public health, safety and general welfare of the residents of the Town of Cheektowaga. Residential rental properties may become a haven for various criminal or disruptive activities that can cause disorder in our community and affect the quality of life of others in the Town of Cheektowaga.

The Town Board of the Town of Cheektowaga desires to minimize and control the adverse effects caused by illegal and nuisance activities which may occur at residential rental properties, thereby protecting the health, safety and welfare of our citizens; and preserving the quality of life, property values and the character of neighborhoods and businesses.

It is the purpose of this law to implement a registration requirement for residential rental property owners in order to curb criminal activity and disorder on residential rental properties in the Town of Cheektowaga.

Section 2. Definitions.

Criminal Activity – unlawful activity consisting of drug activity, weapons possession, assault, domestic violence, murder, assault, sexual assault, gang activity or other activity proscribed by the Penal Law of the State of New York.

Dwelling – a single family, two-family or multi-family dwelling which is rented or for rent.

Dwelling Unit – an individual rental unit in dwelling

Owner/Landlord – the owner or owners of a dwelling, or a mortgagee or vendee in possession, assignee of rents, receiver, executor, trustee or agent.

Police Report – a report issued by a Town Police Officer after said officer has responded to a complaint alleging the occurrence of criminal activity or a public nuisance.

Property Manager – a person or other entity designated by the owner to manage a dwelling on behalf of the owner

Public Nuisance – activities affecting the quality of life of residents of the Town of Cheektowaga, including violations of the Town’s Noise Law, alcohol-related incidents or other violations of the Code of the Town of Cheektowaga which are enforced by the Town Police Department.

Renter/Lessee/Tenant – any person who rents a dwelling unit from an Owner in the Town of Cheektowaga.

Town – Town of Cheektowaga, exclusive of the villages of Sloan and Depew.

Section 3. Landlord license; registration requirement.

- a. License required. No person shall allow a dwelling unit to be occupied or rented to another for occupancy unless the owner has first obtained a rental housing business license as hereafter provided.
- b. Exemptions. The provisions of this chapter shall not apply to motels; bed-and-breakfast establishments; rooming or boarding houses; hospitals; nursing homes; or other dwelling units which offer or provide medical or nursing services if such units are subject to state or federal licensing or regulations concerning the safety of the users, patients or tenants.
- c. Application for license. Within 30 days after the effective date of this law, the owner of each dwelling shall make written application for a rental housing business license to the Town Council Office. Such application shall be on a form furnished by the Town and shall set forth the following information, in addition to other information required by the Town from time to time which the Town deems necessary to administer, enforce and ensure compliance with the provisions of this law. Failure to provide such information shall be grounds to deny a rental housing business license:
 - i. Names, addresses (business and residence) and telephone number(s) (business and residence) of owner;
 - ii. If the owner is an association, limited liability company, partnership, joint tenancy, tenancy in common or tenancy by the entirety, then the name, address and telephone number of each and every owner, member or general partner shall be indicated on the application;
 - iii. If the owner is a corporation, the principal place of business of the corporation must be provided, along with the name, title and residence address of all officers, directors and managing/general agents must be included on the application;
 - iv. If the owner has designated an agent or managing company to assist the owner with the management of the property, then the name, principal residence address, principal business address and telephone number of such agent or managing company must be included on the application;
 - v. It shall be the responsibility of the owner to properly register any change of address, change of agent or change of any other pertinent information with the Town;
 - vi. For purposes of this law, a post office box shall not be accepted as the owner's business or residence address. Furthermore, the dwelling intended to be licensed shall not be accepted as the owner's address unless it is the principal place or residence of the owner;
 - vii. For purposes of this law, if the owner does not reside in or have its place of business in the County of Erie, then the owner must have a property manager located in the County of Erie. If the owner does not reside or have a business located in the County of Erie, then the owner must designate a property manager located in the County of Erie who can accept service of process.
 - viii. The owner shall specify the address to which all notices and invoices for fees are to be forwarded.
- d. License Application Fee. The application fee for a landlord license under this law shall be Ten Dollars (\$10.00) every two (2) years.
- e. Issuance or denial of license. After receipt of the owner's application for a rental housing business license, the Town Council Office shall review same to ensure said application contains all of the required information. If the application is deemed complete, the Town

Council Office, within 30 days, shall forward the owner a Rental Housing Business License. If said application is deemed incomplete, the Town Council Office shall notify the owner, and the owner shall have 30 days in which to supply the required information. If the required information is not supplied by the owner, the application shall be denied.

- f. Effect of failure to make application or denial of rental housing business license. If the owner does not submit the rental housing business license application or fails to supply all of the information required on the application, the owner shall be subject to the following fines:
 - i. \$500.00 per owner for each 30 day period until an acceptable application is submitted;
- g. Recourse if fine is not paid. If the owner neglects or refuses to pay the fine(s) as stated in subsection e. of this section within 30 days after notification, the Town shall add any such fine(s) onto the owner's property tax bill, and it shall become a lien on the property/dwelling.
- h. Term of license. A rental housing business license issued pursuant to this law shall be valid for a period of two (2) years after its issuance, unless sooner revoked pursuant to this law.
- i. Non-transferability of license. A rental housing business license issued pursuant to this law shall not be transferable to any person who has acquired ownership of a dwelling. A new owner is required to file a new application for a rental housing business license within 30 days after acquiring ownership.

Section 4. Criminal or Public Nuisance Activity Occurring on the Dwelling Property. In the event that the Town Police Officer responds to the dwelling unit for reports of criminal activity or public nuisance activity on the dwelling unit; finds that said activity was engaged in or facilitated by the renter, member of the household, guest or other party under the control of the renter; and issues a police report for same, the Town Council Office shall forward a notice to the owner or property manager stating that there was criminal activity or public nuisance activity on the dwelling property. The owner or property manager shall then take appropriate action to notify the tenant to cease any such activity, or evict said tenant. In the event that there are any subsequent incidents at the dwelling unit in the same calendar year in the same dwelling unit relating to activity engaged in, or facilitated by the same renter or a member of his/her household, guest or other party under the control of said renter, the Town Council Office will forward by first class mail a second notice of criminal activity or public nuisance activity to the owner or property manager notice. Subsequent incidents in the same calendar year at the same dwelling unit will be followed by a notice to the owner or property manager, along with a notice of the imposition of the following fines:

- a. Third incident in the same calendar year- \$50.00 fine;
- b. Fourth incident in the same calendar year- \$100.00 fine;
- c. Fifth incident in the same calendar year- \$500.00 fine;
- d. All further incidents in the same calendar year - \$1,000 fine per incident.

If the owner or property manager submits information to the Town Council Office that it is in the process of evicting the tenant in whose dwelling unit the criminal or public nuisance activity is occurring, future impositions of fines will cease. In the event that the owner neglects or refuses to pay the fine(s) as stated in this section within 30 days after notification, the Town shall add such fine(s) onto the dwelling's property tax bill, and it shall become a lien on the property/dwelling.

Section 5. Crime Free/Crime Prevention Lease Addendum – the owner or property manager of a dwelling under this law is encouraged to utilize a Crime Free/Crime Prevention Lease Addendum, an example of which is annexed to this law, to assist the owner or property manager with the eviction of tenants who continue to conduct criminal or public nuisance activity in the dwelling unit.

Section 6. Tenant Information. The Owner of each dwelling is required to maintain information concerning all of its tenants, including the number and names of all occupants, and the full address and telephone numbers of all tenants. In the event of criminal or public nuisance activity on the property, the owner or property manager shall cooperate with the Town Police Department by providing this information to the Town Police Department if so requested.

Section 7. Appeals. Any owner or property manager who is notified of a fine under this law shall have the right to appeal the imposition of said fine to the Town Board of the Town of Cheektowaga. A written request for an appeal shall be made by the owner or property manager within 30 days after the date of the communication notifying the owner or property manager of the fine. The Town Board shall schedule a hearing within 30 days after receipt of said request for appeal. The owner or property manager shall appear at the hearing in person and shall have the right to representation by a person of his or her choice. The owner, property manager or his/her representative shall provide sworn testimony at said hearing. An appeal to the Town Board will stay the imposition of the fine until it renders its decision. The Town Board shall thereafter issue its written decision to uphold the fine or rescind the fine.

Section 8. Severability. If a term, part or provision, section, subdivision or paragraph of this law shall be held to be unconstitutional, invalid or ineffective, in whole or in part, such determination shall not be deemed to affect, impair or invalidate the remaining parts, provisions, sections, subdivisions and paragraphs of this law.

Section 9. Applicability. This law shall be applicable to all dwellings located in the Town of Cheektowaga outside of the villages of Depew and Sloan.

8/31/2011



Town of Cheektowaga

Work Session

~ Minutes ~

3301 Broadway
Cheektowaga, NY 14227

<http://www.town.cheektowaga.ny.us>

Alice Magierski
716-686-3400

Wednesday, September, 14, 2011

6:00 PM

Council Office

I. Call to Order

6:00 PM Meeting called to order on September 14, 2011 at Council Office, Conference Room, Cheektowaga, NY.

Attendee Name	Organization	Title	Status	Arrived
Mary Holtz	Town of Cheektowaga	Supervisor	Present	
Patricia Jaworowicz	Town of Cheektowaga	Councilmember	Absent	
Jeff Swiatek	Town of Cheektowaga	Councilmember	Present	
James Rogowski	Town of Cheektowaga	Councilmember	Present	
Richard Zydel	Town of Cheektowaga	Councilmember	Present	
Charles Markel	Town of Cheektowaga	Councilmember	Present	
Stanley Kaznowski	Town of Cheektowaga	Councilmember	Present	

II. Resolutions



1. RESOLUTION 2011-513

SPECIAL EVENT - John F. Kennedy Junior/Senior High School Homecoming Parade

Sponsored By: Councilmember Rogowski, Councilmember Zydel

WHEREAS, by resolution dated May 1, 1995, this Town Board adopted a Special Events policy, which requires anyone wishing to hold a special event in the Town to file an application and supporting documentation, fees, etc. to the Town Clerk prior to the special event, and

WHEREAS, the Student Council of John F. Kennedy Junior/Senior High School has made application to hold its Homecoming Parade on Saturday, September 17, 2011, beginning at 1:00 p.m. (parade route attached); and

WHEREAS, this Board has reviewed the aforementioned application, which application has been approved by the Cheektowaga Police Department, and has no objection to same, and

WHEREAS, due to the nature of the event, this Town Board hereby waives the following requirements: Submittal of plan for sanitary facilities;

- 1) Submittal of site plan;
- 2) Requirement that application be made at least 60 days prior to the date of the special event;
- 3) Submittal of Security Plan;
- 4) Submittal of Fire Prevention/Emergency Services Plan.

NOW, THEREFORE, BE IT

RESOLVED, that this Town Board hereby approves the aforementioned application of the Student Council of John F. Kennedy Junior/Senior High School for the aforementioned parade to be held on Saturday, September 17, 2011, and BE IT FURTHER

RESOLVED, that the Chief of Police be and hereby is directed to provide traffic safety and escort services for such parade and to ensure compliance with Section 1660 (a)(6) of the Vehicle and Traffic Law.

RESULT:	ADOPTED [UNANIMOUS]
MOVER:	James Rogowski, Councilmember
SECONDER:	Richard Zydel, Councilmember
AYES:	Holtz, Swiatek, Rogowski, Zydel, Markel, Kaznowski
ABSENT:	Patricia Jaworowicz



2. RESOLUTION 2011-514

Adopt Whistleblower Policy

Sponsored By: Holtz, Swiatek, Rogowski, Zydell, Markel, Kaznowski

BE IT RESOLVED, that this Town Board hereby adopts the attached Whistleblower Policy.

Attachments:

Whistleblower Policy Final (DOC)

RESULT: ADOPTED [UNANIMOUS]
MOVER: Mary Holtz, Supervisor
SECONDER: Jeff Swiatek, Councilmember
AYES: Holtz, Swiatek, Rogowski, Zydell, Markel, Kaznowski
ABSENT: Patricia Jaworowicz



3. RESOLUTION 2011-515

Adopt Policy Relating to Misuse of Town Resources

Sponsored By: Holtz, Swiatek, Rogowski, Zydel, Markel, Kaznowski

BE IT RESOLVED, that this Town Board hereby adopts the attached Policy Relating to Misuse of Town Resources.

Attachments:

Policy on MISUSE OF TOWN RESOURCES Final(DOC)

RESULT: **ADOPTED [UNANIMOUS]**
MOVER: Mary Holtz, Supervisor
SECONDER: Jeff Swiatek, Councilmember
AYES: Holtz, Swiatek, Rogowski, Zydel, Markel, Kaznowski
ABSENT: Patricia Jaworowicz



4. RESOLUTION 2011-516

Adopt Policy Relating to Hiring/Supervising Relatives

Sponsored By: Holtz, Swiatek, Rogowski, Zydel, Markel, Kaznowski

BE IT RESOLVED, that this Town Board hereby adopts the attached Policy Relating to Hiring/Supervising Relatives.

Attachments:

Policy on Hiring & Supervising Relatives Final (DOC)

RESULT: ADOPTED [UNANIMOUS]
MOVER: Mary Holtz, Supervisor
SECONDER: Jeff Swiatek, Councilmember
AYES: Holtz, Swiatek, Rogowski, Zydel, Markel, Kaznowski
ABSENT: Patricia Jaworowicz

TOWN OF CHEEKTOWAGA WHISTLEBLOWER POLICY

POLICY FOR REPORTING IMPROPER GOVERNMENTAL ACTION AND PROTECTING EMPLOYEES AGAINST RETAILATION

The Town Board of the Town of Cheektowaga hereby declares that it is the policy of the Town of Cheektowaga that the New York State Whistleblower Law (Section 75-b of the Civil Service Law) applies to all employees of the Town of Cheektowaga.

Under the Whistleblower Law, the Town of Cheektowaga cannot and will not dismiss or take disciplinary action against a Town employee because said employee discloses to a governmental body, officer or employee, or law enforcement agency or the judiciary information:

- (i) regarding a violation of law, rule or regulation which violation creates and presents a substantial and specific danger to the public health or safety; or
- (ii) which the employee reasonably believes to be true and reasonably constitutes an “improper governmental action” which is in violation of any federal, state or local law, rule or regulation.

”Improper government action” shall mean any action by the Town or Town employee, or an agent of the Town which is undertaken in the performance of such agent’s official duties, whether or not such action is within the scope of his/her employment, and which is in violation of any federal, state or local law, rule or regulation.

Under the NYS Whistleblower Law, before a Town employee can disclose information referenced above, the employee must make a good faith effort to provide the “appointing authority” (i.e. Town Board, Highway Superintendent) or his/her designee (i.e., Coordinator of Employee Relations, Department Head) the information to be disclosed and give them a reasonable time to take appropriate action (unless there is imminent and serious danger to public health or safety).

If the employee is thereafter disciplined, he/she may argue the defense of the Whistleblower Law before an arbitrator, hearing officer or court; and, if successful, said employee shall be entitled to reinstatement with back pay, etc.

TOWN OF CHEEKTOWAGA **POLICY RELATING TO** **MISUSE OF TOWN RESOURCES**

Town officers and employees shall not use Town letterhead, personnel, equipment, vehicles, supplies or any other Town resources for a non-governmental purpose, nor engage in personal or private activities during times when he or she is required to work for the Town of Cheektowaga.

TOWN OF CHEEKTOWAGA POLICY RELATING TO HIRING/SUPERVISING RELATIVES

Except as otherwise required by law:

- (a) No Town officer or employee, either individually or as a member of a board, may participate in any decision specifically to appoint, hire, promote, discipline or discharge a relative for any position at, for or within the Town of Cheektowaga.
- (b) No Town officer or employee may directly supervise a relative in the performance of the relative's official powers or duties.



Town of Cheektowaga

Regular Meeting

~ Minutes ~

3301 Broadway
Cheektowaga, NY 14227
<http://www.town.cheektowaga.ny.us>

Alice Magierski
716-686-3400

Monday, September, 19, 2011

6:45 PM

Council Chambers

I. Call to Order

6:45 PM Meeting called to order on September 19, 2011 at Council Chambers, 3301 Broadway St, Cheektowaga, NY.

Attendee Name	Organization	Title	Status	Arrived
Mary Holtz	Town of Cheektowaga	Supervisor	Present	
Patricia Jaworowicz	Town of Cheektowaga	Councilmember	Present	
Jeff Swiatek	Town of Cheektowaga	Councilmember	Present	
James Rogowski	Town of Cheektowaga	Councilmember	Present	
Richard Zydel	Town of Cheektowaga	Councilmember	Present	
Charles Markel	Town of Cheektowaga	Councilmember	Present	
Stanley Kaznowski	Town of Cheektowaga	Councilmember	Present	

2. Additional Attendees

Thomas Adamczak, Supervising Building and Plumbing Inspector
Jerry Gabryszak, Director of Community Development
Brian Krause, Director of Finance and Administration
John Marriott, Planning Board Chairman
William Pugh, Town Engineer
Anthony Romano, Coordinator of Employee Relations
Kevin Schenk, Town Attorney
David Zack, Chief of Police

II. Public Comment Period

III. Public Hearings

1. Local Law Intro 2011-2 - Landlord Licensing Law

This being the time and place advertised for a Public Hearing, the Supervisor directed the Town Clerk to present that such notice has been duly published and posted; upon the order of the Supervisor such proof was duly filed.

The Supervisor announced that the Town Board would hear all persons interested in the subject of the hearing. Comments were heard, after which the Supervisor declared the hearing closed, decision was reserved.

RESULT: CLOSED [UNANIMOUS]
MOVER: Mary Holtz, Supervisor
SECONDER: Jeff Swiatek, Councilmember

AYES: Holtz, Jaworowicz, Swiatek, Rogowski, Zydel, Markel, Kaznowski

IV. Resolutions



1. RESOLUTION 2011-517

Warrant

Sponsored By: Councilmember Swiatek, Supervisor Holtz

BE IT RESOLVED, that the following Vouchers & Warrants submitted to the Town of Cheektowaga prior to September 16, 2011 are hereby approved and made a part hereof;

General Fund	\$ 699,331.89
Risk Retention Fund	25,723.52
HUD Housing Rehabilitation	1,750.00
Special Districts Fund	447,241.36
Highway Fund	143,437.70
Capital Fund	532,891.79
Trust & Agency Fund	14,938.53
HUD CDBG Fund	49,131.78
Part Town Fund	<u>37,014.31</u>
	\$1,951,460.88

RESULT:	ADOPTED [UNANIMOUS]
MOVER:	Jeff Swiatek, Councilmember
SECONDER:	Mary Holtz, Supervisor
AYES:	Holtz, Jaworowicz, Swiatek, Rogowski, Zydel, Markel, Kaznowski



2. RESOLUTION 2011-518

Call for Public Hearing - Increase and Improvement of Facilities of the Town-Wide Consolidated Drainage District - Southgate, Century and Cedar Rds

Sponsored By: Councilmember Kaznowski, Councilmember Zydel

In the Matter

of the

Increase and Improvement of Facilities of the Town-wide Consolidated Drainage District, in the Town of Cheektowaga, in the County of Erie, New York, pursuant to Section 202-b of the Town Law

Offered by: Councilmember Stanley J. Kaznowski

Seconded by: Councilmember Richard A. Zydel

ORDER CALLING FOR A PUBLIC HEARING TO BE HELD ON OCTOBER 3, 2011

WHEREAS, the Town Board of the Town of Cheektowaga (herein called the "Town Board" and the "Town", respectively), in the County of Erie, New York, on behalf of the Town-wide Consolidated Drainage District, in the Town (herein called the "District"), has requested the Town Engineer, an engineer duly licensed by the State of New York (herein called the "Engineer"), to prepare a map, plan and report for the proposed an increase and improvement of facilities of the District, consisting of storm sewer trunkline improvements to be constructed on Southgate Rd, South Century Rd, a portion of Cedar Rd, and through permanent easement areas acquired from Ken-Vil Associates Limited Partnerships and other related drainage improvements, and any ancillary work in connection therewith, as described in the report prepared by the Town Engineer, dated September 2011, at the estimated maximum cost of \$900,000; and

WHEREAS, pursuant to the State Environmental Quality Review Act (SEQRA), constituting Article 8 of the Environmental Conservation Law, and 6 N.Y.C.R.R., Regulations Part 617, the Town Board, as lead agency, has given due consideration to the impact that such increase and improvement of facilities may have on the environment and, having reviewed a Short Environmental Assessment Form, the Town Board has determined that such project shall not have any significant effect on the environment and has issued a Negative Declaration for purposes of SEQRA;

Now, therefore, be it

ORDERED, that a meeting of the Town Board of the Town be held at the Town Hall, 3301 Broadway, Cheektowaga, New York, on the 3rd day of October, 2011 at 6:45 P.M. o'clock P.M. (Prevailing Time) to consider said increase and improvement of facilities of the District and to hear all persons interested in the subject thereof concerning the same and for such other action on the part of the Town Board with relation thereto as may be required by law; and be it,

FURTHER ORDERED, that the Town Clerk publish at least once in the "CHEEKTOWAGA BEE," hereby designated as the official newspaper of the Town for such publication, and post on the sign board of the Town maintained pursuant to subdivision 6 of Section 30 of the Town Law, a Notice of such public hearing certified by said Town Clerk, substantially in the form attached hereto as Exhibit A, the first publication thereof and said posting to be not less than ten (10) nor more than twenty (20) days before the date of such public hearing.

DATED: September 19, 2011

TOWN BOARD OF THE TOWN OF CHEEKTOWAGA

(SEAL)

Exhibit A

NOTICE OF PUBLIC HEARING

NOTICE IS HEREBY GIVEN that the Town Board of the Town of Cheektowaga, in the County of Erie, State of New York, will meet at the Town Hall, 3301 Broadway, Cheektowaga, New York, on October 3, 2011, at 6:45 P.M. o'clock P.M. (Prevailing Time), for the purpose of conducting a public hearing in relation to the increase and improvement of facilities of Town-wide Consolidated Drainage District, consisting of storm sewer trunkline improvements to be constructed on Southgate Rd, South Century Rd, a portion of Cedar Rd, and through permanent easement areas acquired from Ken-Vil Associates Limited Partnerships and other related drainage improvements, and any ancillary work in connection therewith, as described in the report prepared by the Town Engineer, dated September 2011, at the aggregate estimated maximum cost of \$900,000.

At said public hearing, the Town Board will hear all persons interested in said subject matter thereof.

Dated: September 19, 2011
Cheektowaga, New York

BY ORDER OF THE TOWN BOARD OF THE
TOWN OF CHEEKTOWAGA, COUNTY OF ERIE,
STATE OF NEW YORK

By

Alice Magierski, Town Clerk
Town of Cheektowaga

RESULT:	ADOPTED [UNANIMOUS]
MOVER:	Stanley Kaznowski, Councilmember
SECONDER:	Richard Zydell, Councilmember
AYES:	Holtz, Jaworowicz, Swiatek, Rogowski, Zydell, Markel, Kaznowski



3. RESOLUTION 2011-519

Notice to Bidders Asbestos Surveys for Properties Located at 3048 William Street, 74 Hoerner Avenue, 15 Atwood Place, 44A Windwood Court, and 29E Glenwood Court

Sponsored By: Councilmember Markel, Councilmember Kaznowski

WHEREAS, pursuant to the Town's Unsafe Buildings Law, Nussbaumer & Clarke, Inc., a duly authorized agent of the Town of Cheektowaga, has issued written reports stating that the residential buildings located at 3048 William Street, 74 Hoerner Avenue, 15 Atwood Place, 44A Windwood Court, and 29E Glenwood Court, are unsafe and recommended that such buildings be demolished; and

WHEREAS, the owners and lienholders of said properties were notified to demolish the buildings on said properties, and no action for these demolitions has been taken to date; and

WHEREAS, hearings were held in front of this Board on the 6th day of September, 2011, concerning said unsafe buildings and requested demolitions; and

WHEREAS, the Town of Cheektowaga needs to take action to demolish the buildings located on said properties in the event the owners of same do not do so; and

WHEREAS, prior to demolition of each property, the Town needs to have an asbestos survey done to determine whether there is asbestos in each building; and

WHEREAS, a Notice to Bidders has been prepared for these matters; NOW, THEREFORE, BE IT

RESOLVED, that this Town Board hereby approves the Notice to Bidders for the Asbestos Surveys, etc. for the following properties located in the Town of Cheektowaga:

- 3048 William Street
- 74 Hoerner Avenue
- 15 Atwood Place
- 44A Windwood Court
- 29E Glenwood Court

and BE IT FURTHER

RESOLVED, that the Town Clerk's Office be and hereby is directed to publish the attached Notice to Bidders in the CHEEKTOWAGA BEE; and BE IT FURTHER

RESOLVED, that bids for the Asbestos Surveys, Specifications and Air Monitoring Services for 3048 William Street, 74 Hoerner Avenue, 15 Atwood Place, 44A Windwood Court, and 29E Glenwood Court shall be due no later than September 28, 2011 at 11:00 A.M. at the Town Clerk's Office, and BE IT FURTHER

RESOLVED, that the Town Clerk be and hereby is appointed as the officer to open said bids in the Council Chambers of Town Hall on Wednesday, September 28, 2011 at 11:00 a.m.

NOTICE TO BIDDERS FOR ASBESTOS SURVEYS, SPECIFICATIONS & AIR MONITORING SERVICES FOR PROPERTIES LOCATED AT 3048 WILLIAM STREET, 74 HOERNER AVENUE, 15 ATWOOD PLACE, 44A WINDWOOD COURT, and 29E GLENWOOD COURT, CHEEKTOWAGA, NEW YORK

NOTICE IS HEREBY GIVEN that the Town of Cheektowaga is seeking bids from qualified contractors to prepare asbestos surveys for properties located at 3048 William Street, 74 Hoerner Avenue, 15 Atwood Place, 44A Windwood Court, and 29E Glenwood Court, Cheektowaga, New York. The contractors shall also submit quotes for asbestos specifications for demolition and air monitoring services during the demolition of each building if asbestos is found in said buildings.

Sealed proposals for said services will be received and considered by the Town Board of the Town of Cheektowaga on Wednesday, September 28, 2011 at 11:00 A.M. at the Town Hall, 3301 Broadway, Cheektowaga, New York.

Information for Bidders and Specifications may be obtained from the Town Clerk at her office in said Town Hall.

The Town Board reserves the right to consider informal any proposal not prepared and submitted in accordance with the specifications, and may waive informalities and make an award to the vendor who, in its opinion, offers the best deal for the Town.

BY ORDER OF THE TOWN BOARD OF THE TOWN OF CHEEKTOWAGA, ERIE COUNTY, NEW YORK.

Dated: September 19, 2011

ALICE MAGIERSKI
Town Clerk

RESULT:	ADOPTED [UNANIMOUS]
MOVER:	Charles Markel, Councilmember
SECONDER:	Stanley Kaznowski, Councilmember
AYES:	Holtz, Jaworowicz, Swiatek, Rogowski, Zydel, Markel, Kaznowski



4. RESOLUTION 2011-520

Approve Auction of Town Surplus Vehicles and Equipment

Sponsored By: Councilmember Swiatek, Supervisor Holtz

WHEREAS, the Town wishes to dispose of a number of surplus motor vehicles and equipment no longer needed for Town use and

WHEREAS, sale of surplus property by the Town is authorized by Section 64 of the Town law of the State of New York and

RESOLVED, that the Town hereby retains Auctions International, Inc., 808 Borden Road, Cheektowaga, New York, as per the submitted contract, to conduct a sale of the surplus Town vehicles and equipment identified on the attached list at an on-line auction to be held on its website and BE IT FURTHER

RESOLVED, that the Supervisor of the Town of Cheektowaga be and hereby is authorized to execute the aforementioned contract and any and all documents that may be required to effectuate the sale and transfer of all said vehicles and equipment.

Make	Model	VIN #	Miles	Fleet #
Ford	L900 Single Axle 8 ton	1FDYK90L2SVA38097	52,651	48
Ford	L900 Single Axle 8 ton	1FDYK90L4SVA38098	61,193	53

RESULT:	ADOPTED [UNANIMOUS]
MOVER:	Jeff Swiatek, Councilmember
SECONDER:	Mary Holtz, Supervisor
AYES:	Holtz, Jaworowicz, Swiatek, Rogowski, Zydel, Markel, Kaznowski



5. RESOLUTION 2011-521

Demolition of Accessory Structure/69 Fairhaven Dr.

Sponsored By: Councilmember Markel, Councilmember Kaznowski

WHEREAS, Town of Cheektowaga Law for the Administration and Enforcement of the Codes of New York State; and the Property Maintenance Code of New York State require that all vacant structures and premises shall be maintained in clean, safe, secure and sanitary conditions so as not to cause a blighting problem or adversely affect the public health or safety and all nuisances abated, AND

WHEREAS, the Town of Cheektowaga has received notification of an unsafe structure and premises located at 69 Fairhaven Drive, Cheektowaga, New York SBL# 91.08-6-26 that is a danger to the safety of others, and records kept by the Assessors Office identify Dolores L. Daniel, 69 Fairhaven Drive, Cheektowaga, New York 14225, as the owner AND

WHEREAS, an inspection of such premises was conducted at 69 Fairhaven Drive, by the Housing and Neighborhood Preservation Office, AND

WHEREAS, such inspection found the premises to be deteriorated, vacant, a hazard, and a danger to the safety and well being of others, AND

WHEREAS, the Town of Cheektowaga Housing and Neighborhood Preservation Office properly notified the property owner in accordance with the Town of Cheektowaga Law for the Administration and Enforcement of the Codes of New York State, and the owner failed to take actions to safeguard the premises, AND

WHEREAS, these conditions require the Town of Cheektowaga Housing and Neighborhood Preservation Office to take immediate steps to safeguard the premises to protect the health and safety of others and abate all nuisances, NOW, THEREFORE BE IT

RESOLVED, that pursuant to Section 70-7A.(5) and Section 70-8 of the Town of Cheektowaga Law for the Administration and Enforcement of the Codes of New York State that the vacant structure premises be safeguarded and all nuisances abated; and all costs incurred be assessed against the property hereinbefore described.

RESULT:	ADOPTED [UNANIMOUS]
MOVER:	Charles Markel, Councilmember
SECONDER:	Stanley Kaznowski, Councilmember
AYES:	Holtz, Jaworowicz, Swiatek, Rogowski, Zydel, Markel, Kaznowski



6. RESOLUTION 2011-522

Special Event - Cheektowaga Central High School Homecoming Parade

Sponsored By: Councilmember Rogowski, Councilmember Zydel

WHEREAS, by resolution dated May 1, 1995, this Town Board adopted a Special Events policy, which requires anyone wishing to hold a special event in the Town to file an application and supporting documentation, fees, etc. to the Town Clerk prior to the special event, and

WHEREAS, the Cheektowaga Central School District has made application to hold its Homecoming Parade on Friday, September 23, 2011, beginning at 5:30 p.m. (parade route attached); and

WHEREAS, this Board has reviewed the aforementioned application, which application has been approved by the Cheektowaga Police Department, and has no objection to same, and

WHEREAS, due to the nature of the event, this Town Board hereby waives the following requirements: Submittal of plan for sanitary facilities;

- 1) Submittal of site plan;
- 2) Requirement that application be made at least 60 days prior to the date of the special event;
- 3) Submittal of Security Plan;
- 4) Submittal of Fire Prevention/Emergency Services Plan.

NOW, THEREFORE, BE IT

RESOLVED, that this Town Board hereby approves the aforementioned application of the Cheektowaga Central School District for the aforementioned Homecoming Parade to be held on Friday, September 23, 2011, and BE IT FURTHER

RESOLVED, that the Chief of Police be and hereby is directed to provide traffic safety and escort services for such parade and to ensure compliance with Section 1660 (a)(6) of the Vehicle and Traffic Law.

RESULT:	ADOPTED [UNANIMOUS]
MOVER:	James Rogowski, Councilmember
SECONDER:	Richard Zydel, Councilmember
AYES:	Holtz, Jaworowicz, Swiatek, Rogowski, Zydel, Markel, Kaznowski



7. RESOLUTION 2011-523

Order Construction of Sidewalks at 120 Galleria Dr

Sponsored By: Councilmember Swiatek, Supervisor Holtz

WHEREAS, Chapter 210 of the Code of the Town of Cheektowaga (Streets and Sidewalks) sets forth the specifications for the construction of sidewalks in the Town of Cheektowaga, and

WHEREAS, Section 200-a of the Town Law of the State of New York authorizes a town board to adopt a resolution to require a property owner to install a sidewalk in front of his property, and

WHEREAS, the Town has contacted the owner of 120 Galleria Drive, where presently there are no sidewalks, and notified said owner of the need for sidewalks, and

WHEREAS, the owner of 120 Galleria Drive has informed that Town that it prefers that the Town perform the work and add the cost of same onto its tax bill, NOW, THEREFORE, BE IT

ORDERED, that the owner of 120 Galleria Drive be and hereby is directed to construct sidewalks abutting said property on or before September 24, 2011 in accordance with the Town's Streets and Sidewalks Law, and BE IT FURTHER

ORDERED, that, should said property owner neglect to or choose to not construct such sidewalks as so notified before September 24, 2011, the Town will cause such sidewalks to be constructed; and will assess/charge the property owner the cost of same over a period of five (5) years on the County/Town tax bill, with interest at the rate of 6.00 % as authorized by State law; or, at the property owner's option, payment may be made in one lump sum before October 15, 2011, and BE IT FURTHER

ORDERED, that the Town Clerk be and hereby is directed to notify the owner of 120 Galleria Drive of this Order by sending the attached Notice via certified mail to said owner at its address as it appears on the Town Assessment Roll.

**NOTICE OF ADOPTION OF ORDER
OF THE TOWN BOARD OF THE TOWN OF CHEEKTOWAGA**

TAKE NOTICE THAT, pursuant to a resolution adopted by the Town Board of the Town of Cheektowaga on September 19, 2011,

YOU ARE HEREBY ORDERED to construct a sidewalk in front of your property.

Such work must be completed on or before **September 24, 2011**

In the event you neglect or choose not to perform this work before the specified date, be advised that the Town of Cheektowaga shall cause such work to be done. The

Town will assess the expense thereof (including interest at the rate of 6.00%) against your property in five (5) annual installments; this amount will be added to your town tax bills for the next five (5) years and shall become a lien on your property. In the alternative, you may pay your share of the cost directly to the Town provided you do so on or before October 15, 2011.

If the Town performs the work, it is estimated that your cost for sidewalk construction work will be approximately \$4,650.00.

BY ORDER OF THE TOWN BOARD OF THE TOWN OF CHEEKTOWAGA, ERIE COUNTY, NEW YORK.

DATED: September 19, 2011

ALICE MAGIERSKI
Town Clerk

RESULT:	ADOPTED [UNANIMOUS]
MOVER:	Jeff Swiatek, Councilmember
SECONDER:	Mary Holtz, Supervisor
AYES:	Holtz, Jaworowicz, Swiatek, Rogowski, Zydel, Markel, Kaznowski



8. RESOLUTION 2011-524

Engage Design Consultant for the Rein Road Bridge Rehabilitation Project

Sponsored By: Councilmember Swiatek, Supervisor Holtz

WHEREAS, the Town of Cheektowaga was awarded a grant for Federal Highway Bridge Rehabilitation and Replacement (HBRR) Funds to rehabilitate the Rein Road Bridge over Ellicott Creek, PIN 5758.38, which grant is required to be administered in accordance with New York State Department of Transportation guidelines and procedures for Locally Administered Federal Aid Projects, AND

WHEREAS, by resolution dated October 4, 2010 this Town Board authorized the Town Supervisor to execute a Federal Aid Local Project Agreement for the Preliminary Engineering (Design I-VI) phase of said project with the apportionment cost of this project to be at the ratio of 80% Federal funds and 20% non-Federal funds, AND

WHEREAS, under the Procedures for Locally Administered Federal Aid Projects, the Town is required to retain a consultant to design the project, which selection is to be performed by an appointed Selection Committee, AND

WHEREAS, the Town of Cheektowaga Consultant Selection Committee has completed the review of the Expression of Interest/Qualification Statement submissions received from 14 firms associated with the provision of Preliminary and Final Design Services, Phases I-VI for the subject Federally and Locally Funded Project, and has recommended that the firm of Abate Associates, 4455 Genesee Street, Cheektowaga, New York 14225 be retained for the aforesaid design and related tasks for this bridge rehabilitation project, NOW, THEREFORE, BE IT

RESOLVED, that the professional services proposal of Abate Associates, Engineers and Surveyors P.C. as submitted to the Town Engineer for the various tasks associated with the bridge rehabilitation project as outlined in the Engineering Consultant Agreement is accepted and approved, AND, BE IT FURTHER

RESOLVED, that the Supervisor, on behalf of this Town Board, is hereby directed and authorized to sign said agreement with Abate Associates, AND, BE IT FURTHER

RESOLVED, that the cost of said professional services in an amount not to exceed \$199,670.00 shall be chargeable to Account #300-9950-8000 of which 80% is eligible for Federal grant funded reimbursement.

RESULT:	ADOPTED [UNANIMOUS]
MOVER:	Jeff Swiatek, Councilmember
SECONDER:	Mary Holtz, Supervisor
AYES:	Holtz, Jaworowicz, Swiatek, Rogowski, Zydel, Markel, Kaznowski



9. RESOLUTION 2011-525

Youth & Recreation Terminations

Sponsored By: Councilmember Zydel, Councilmember Rogowski

Youth and Recreation Terminations

BE IT RESOLVED that the individuals listed below be and herby are terminated in the Department of Youth & Recreational Services, effective as indicated:

Tyia Acoff	8/10/2011	14215
Denzel Adside	Never Worked	14211
Kelly Astyk	8/18/2011	14227
Christopher Balash	8/24/2011	14215
Michaela Barone	8/19/2011	14225
Adam Barrett	8/27/2011	14225
Jacob Bauer	8/26/2011	14227
Brad Bauman	8/14/2011	14227
Austin Baumgart	Never Worked	14225
Timothy Baumgart	8/22/2011	14225
Cody Berns	Never Worked	14225
Robert Bommer	8/24/2011	14225
Levi Bourdette	8/23/2011	14225
Emily Bowen	8/12/2011	14225
Lillith Boyd-Gamel	8/12/2011	14225
Samantha Burton	8/19/2011	14225
Richard Burton, Jr.	8/12/2011	14225
Kenneth Carlucci, III	8/19/2011	14227
Tyler Casillo	8/18/2011	14227
Andrew Charvat	8/24/2011	14225
Danielle Chmurzynski	8/18/2011	14225
Catherine Chojnacki	8/21/2011	14225
David Chwojdak	8/22/2011	14227
Olivia Constantin	8/12/2011	14225
Nicholas Coronado	8/19/2011	14225
Alan Craft	Never Worked	14225
Patrick Crissy	Never Worked	14225
Andrew Deeds	8/27/2011	14211
Justin DelBello	8/12/2011	14227
Kayla Doetterl	8/12/2011	14227
Julianne Doetterl	8/26/2011	14227
Justen Dohn	Never Worked	14225
Margaret Drzewiecki	8/19/2011	14225
Matthew Eckle	8/24/2011	14225
Alex Eisenhauer	Never Worked	14225
Jessica Elston	8/12/2011	14225
Sharrieff Fareed-Muhammad	8/19/2011	14215
Melissa Farruggio	8/22/2011	14227
Matthew Gaczewski	5/3/2011	14225
Joshua Galente	8/24/2011	14206

Michael Gandt	8/19/2011	14043
Holly Gasiacki	12/12/2010	14225
Brian Grabiec	8/12/2011	14225
Dakota Grantham	8/27/2011	14225
Melanie Grzebinski	8/12/2011	14227
Jonathan Gworek	8/18/2011	14227
Julia Harvey	8/20/2011	14225
Bryan Hastings	Never Worked	14043
Rachel Hermanski	8/22/2011	14225
Matthew Hockwater	8/19/2011	14227
Donte' Hood	6/7/2011	14225
Catherine Huber	8/19/2011	14225
Melissa Huber	8/16/2011	14225
Samantha Johnston	8/27/2011	14206
Sarah Kapanek	8/18/2011	14206
Trevor Karek	8/19/2011	14225
Michael Keller	8/19/2011	14225
Christopher Kelley	8/23/2011	14215
David Kerling	8/23/2011	14225
Christopher Kiripolsky	8/23/2011	14215
Sara Kojm	8/12/2011	14215
Jan Kostran	8/22/2010	14043
Alissa Kowalski	8/24/2011	14206
Brandon Kruse	Never Worked	14206
Kayla Kuechle	8/19/2011	14225
Rachel Kuechle	8/19/2011	14225
Tyler Kunkel	8/14/2011	14225
Keith Kwiatkowski	8/24/2011	14227
Matthew Lanning	8/24/2011	14225
Austin Lauer	8/12/2011	14225
Michael Lewandowski	8/26/2011	14043
Matthew Maciejewski	5/5/2011	14227
Nicole Maciejewski	8/20/2011	14227
Elicia MacTarnaghan	8/19/2011	14043
Heidi Maziarz	Never Worked	14043
Noah McGhee	8/19/2011	14225
Adam McPherson	8/19/2011	14225
Kayla Mergenthaler	8/28/2011	14225
Emily Metzger	8/19/2011	14225
Joshua Miller	8/12/2011	14211
Alicia Misiak	8/24/2011	14227
Elizabeth Monaco	8/23/2011	14225
Cassidy Moore	8/12/2011	14225
Toni Morrison	8/18/2011	14225
Allison Musial	8/23/2011	14225
Eric Nash	8/24/2011	14206
Jamie Nash	8/24/2011	14206
John Nazzarett	8/12/2011	14227
Paul A Nazzarett	8/20/2011	14227
Tyler Nosal	8/19/2011	14225
Mindy Odrobina	8/23/2011	14043
Nicole Odrobina	8/23/2011	14043
Samantha Panzica	11/28/2010	14225
Jordan Partyka	Never Worked	14043

Corey Patrzyk	8/26/2011	14043
Tyler Pawlowski	8/19/2011	14225
Keileigh Pecyne	3/24/2011	14227
Katelin Petrachuk	8/19/2011	14227
Christie Petre	8/27/2011	14211
Stephen Pfalzer	8/31/2011	14043
Kyle Polanski	8/31/2011	14043
Samantha Poules	8/12/2011	14227
Hajan Quarles	Never Worked	14211
Jacob Radlich	8/19/2011	14225
James Rogers	8/27/2011	14206
Erin Rozewicz	8/24/2011	14227
Nicholas Russell	8/26/2011	14206
Rose Rustowicz	8/19/2011	14225
Trevor Sacilowski	8/23/2011	14225
Andrew Samer	8/26/2011	14227
Jacob Sauer	8/26/2011	14227
Sierra Schraufstetter	8/12/2011	14225
Brian Sheldon	8/31/2011	14227
Adam Skowron	8/23/2011	14227
Alyssa Slinkosky	8/18/2011	14225
Courtney Smith	8/12/2011	14206
Danielle Smith	8/12/2011	14206
Tyler Smith	8/24/2011	14043
Austin Snyder	8/25/2011	14225
Ashley Sokol	8/23/2011	14227
Emily Speidel	8/22/2011	14225
Gary Steltermann	8/12/2011	14225
Joshua Strzelec	8/12/2011	14211
Mark Stucke	Never Worked	14225
Christopher Suchan	8/24/2011	14227
Christian Suszek	Never Worked	14206
Joshua Swigonski	Never Worked	14227
Katie Tomaschko	8/19/2011	14225
Lauren Tomaschko	8/19/2011	14225
Michael Tomczak	8/24/2011	14227
Jonathan Townsend	8/31/2011	14214
Daniel Urshel	8/12/2011	14043
Zachary Uzar	8/24/2011	14227
Bradley Vargo	8/24/2011	14225
Aaron Wanat	8/18/2011	14043
Daniel Wasielewski	8/20/2011	14225
Alexis Wayne	8/12/2011	14227
Jennifer Weber	8/23/2011	14225
Catherine Weibel	Never Worked	14225
Tyler Welsh	8/12/2011	14225
Brandon Wheeler	8/16/2011	14225
Harley Wiertel	8/12/2011	14227
Kendal Wiertel	8/12/2011	14227
Delorean Williamson	Never Worked	14225
Alexandria Wnuk	8/24/2011	14043
Michael Wrona	8/24/2011	14225
Torrie Wydysh	8/27/2011	14225
Anastasia Zarbo	8/19/2011	14227

Michael Zarbo	8/20/2011	14227
John Zastempowski, IV	8/19/2011	14227

Motion by Councilmember Rogowski; Seconded by Councilmember Markel to waive the reading of names for the following two (2) resolutions: 2011-525 and 2011-526. Motion Carried.

RESULT: **ADOPTED [UNANIMOUS]**
MOVER: Richard Zydel, Councilmember
SECONDER: James Rogowski, Councilmember
AYES: Holtz, Jaworowicz, Swiatek, Rogowski, Zydel, Markel, Kaznowski



10. RESOLUTION 2011-526

Termination of Part-Time/Seasonal Employees

Sponsored By: Councilmember Swiatek, Supervisor Holtz

BE IT RESOLVED, that the following seasonal and/or part-time employees be and hereby are terminated as listed:

SANITATION DEPARTMENT

Gregory S. Pigeon effective 8/27/11

SENIOR SERVICES

Joseph Wodowski effective 6/11/11

FACILITIES DEPARTMENT

Daniel Morgan effective 8/19/11

Brendan Hammer effective 8/19/11

Eric Tomczak effective 7/22/11

Jonathan Heisler effective 8/5/11

Timothy Stevenson effective 9/1/11

RESULT:	ADOPTED [UNANIMOUS]
MOVER:	Jeff Swiatek, Councilmember
SECONDER:	Mary Holtz, Supervisor
AYES:	Holtz, Jaworowicz, Swiatek, Rogowski, Zydel, Markel, Kaznowski



11. RESOLUTION 2011-527

Appointment of Student Interns (Justice Court/Police Department)

Sponsored By: Councilmember Jaworowicz, Councilmember Swiatek

WHEREAS, Shannon Chase of Cheektowaga, New York, whom is a student at Bryant & Stratton College, has requested to participate in the student internship program in the Justice Court; AND

WHEREAS, this individual has been interviewed by the Justice Court and the Justice Court is willing to afford her the opportunity to intern in the Justice Court; NOW, THEREFORE, BE IT

RESOLVED, that Shannon Chase of Cheektowaga, New York, be and hereby is authorized to participate as an unpaid intern in the Justice Court from September 20 through November 22, 2011, subject to her execution of a Waiver of Liability and Agreement of Confidentiality; AND, BE IT FURTHER

RESOLVED, that the Supervisor be and hereby is authorized and directed to execute the Agreement of Confidentiality, and all other documents necessary to effectuate this student internship in the Justice Court; AND, BE IT FURTHER

RESOLVED, that Derek Robinson of Sloan, New York (a student at Bryant & Stratton College), Tabitha Harris of Afton, New York (a student at Hilbert College) and Samantha Tedesco of Orchard Park, New York (a student at Hilbert College) have requested to participate in the student internship program in the Police Department; AND

WHEREAS, these individuals have been interviewed by the Police Department and the Police Department is willing to afford them the opportunity to intern in the Police Department; NOW, THEREFORE, BE IT

RESOLVED, that Derek Robinson of Sloan, New York, Tabitha Harris of Afton, New York, and Samantha Tedesco of Orchard Park, New York be and hereby are authorized to participate as unpaid interns in the Police Department from September 1 through December 31, 2011, subject to their execution of a Waiver of Liability and Agreement of Confidentiality; AND, BE IT FURTHER

RESOLVED, that the Supervisor be and hereby is authorized and directed to execute the Agreement of Confidentiality, and all other documents necessary to effectuate these student internships in the Police Department.

RESULT:	ADOPTED [UNANIMOUS]
MOVER:	Patricia Jaworowicz, Councilmember
SECONDER:	Jeff Swiatek, Councilmember
AYES:	Holtz, Jaworowicz, Swiatek, Rogowski, Zydel, Markel, Kaznowski



12. RESOLUTION 2011-528

Travel Authorization Police Department/Lieutenant Kenneth Rusin

Sponsored By: Councilmember Jaworowicz, Councilmember Swiatek

WHEREAS, the "Bloodstain Pattern Analysis Course" is being held September 26 through September 30, 2011 at the Erie County Fire Training Town in Cheektowaga, New York; AND

WHEREAS, Lieutenant Kenneth Rusin has requested authorization to attend said course; AND

WHEREAS, Police Chief David Zack has submitted a request for travel authorization along with the proper paperwork in a timely manner; AND

WHEREAS, the total cost to the Town shall not exceed \$200; AND

WHEREAS, these expenses have been budgeted by the Police Department; NOW, THEREFORE, BE IT

RESOLVED, that Lieutenant Kenneth Rusin be and hereby is authorized to attend the "Bloodstain Pattern Analysis Course" being held September 26 through September 30, 2011 at the Erie County Fire Training Town in Cheektowaga, New York.

RESULT:	ADOPTED [UNANIMOUS]
MOVER:	Patricia Jaworowicz, Councilmember
SECONDER:	Jeff Swiatek, Councilmember
AYES:	Holtz, Jaworowicz, Swiatek, Rogowski, Zydel, Markel, Kaznowski



13. RESOLUTION 2011-529

Travel Authorization Police Department/Police Chief David Zack

Sponsored By: Councilmember Jaworowicz, Councilmember Swiatek

WHEREAS, the “118th Annual International Association of Chiefs of Police Conference and Law Enforcement Education and Technology Exposition” is being held October 22 through October 26, 2011 in Chicago, Illinois; AND

WHEREAS, Police Chief David Zack has requested authorization to attend said conference and exposition; AND

WHEREAS, Police Chief Zack has submitted a request for travel authorization along with the proper paperwork in a timely manner; AND

WHEREAS, the total cost to the Town shall not exceed \$2,365.40; AND

WHEREAS, these expenses have been budgeted by the Police Department; NOW, THEREFORE, BE IT

RESOLVED, that Police Chief David Zack be and hereby is authorized to attend the “118th Annual International Association of Chiefs of Police Conference and Law Enforcement Education and Technology Exposition” being held October 22 through October 26, 2011 in Chicago, Illinois.

RESULT:	ADOPTED [UNANIMOUS]
MOVER:	Patricia Jaworowicz, Councilmember
SECONDER:	Jeff Swiatek, Councilmember
AYES:	Holtz, Jaworowicz, Swiatek, Rogowski, Zydel, Markel, Kaznowski

V. Communications

A. Departmental Communications

1. Town Environmental Advisory Committee - August 31, 2011
2. Town of Cheektowaga 2012 Tentative Benefit Basis Budget

B. General Communications

1. Summons & Complaint: Anthony Rose Vs. Town of Cheektowaga
2. Notice of Claim: Michelle Bane Vs. Town of Cheektowaga
3. Notice of Claim: Niagara Mohawk Power Corp. Dba National Grid Vs. Town of Cheektowaga

4. Notice of Claim: Lloyd Nolan Vs. Town of Cheektowaga

VI. Comments

A. Supervisor's Comments

B. Councilmember's Comments

C. Public Comments

VII. Adjournment

Motion by Supervisor Holtz; Seconded by Councilmember Swiatek to adjourn the meeting.
Time: 9:07 PM

Alice Magierski, Town Clerk



Town of Cheektowaga

Regular Meeting

~ Minutes ~

3301 Broadway
Cheektowaga, NY 14227

<http://www.town.cheektowaga.ny.us>

Alice Magierski
716-686-3400

Monday, October 3, 2011

6:45 PM

Council Chambers

I. Call to Order

6:45 PM Meeting called to order on October 3, 2011 at Council Chambers, 3301 Broadway St, Cheektowaga, NY.

Attendee Name	Organization	Title	Status	Arrived
Mary Holtz	Town of Cheektowaga	Supervisor	Present	
Patricia Jaworowicz	Town of Cheektowaga	Councilmember	Present	
Jeff Swiatek	Town of Cheektowaga	Councilmember	Absent	
James Rogowski	Town of Cheektowaga	Councilmember	Present	
Richard Zydel	Town of Cheektowaga	Councilmember	Present	
Charles Markel	Town of Cheektowaga	Councilmember	Present	
Stanley Kaznowski	Town of Cheektowaga	Councilmember	Present	

2. Additional Attendees

Thomas Adamczak, Supervising Building and Plumbing Inspector
Brian Krause, Director of Finance and Administration
Stephanie Lewandowski, Justice Court
William Pugh, Town Engineer
Kevin Schenk, Town Attorney

II. Public Hearing

1. Increase and Improvement of Facilities of the Town-Wide Consolidated Drainage District - Southgate, Century and Cedar Rds

This being the time and place advertised for a Public Hearing, the Supervisor directed the Town Clerk to present that such notice has been duly published and posted; upon the order of the Supervisor such proof was duly filed.

The Supervisor announced that the Town Board would hear all persons interested in the subject of the hearing. Comments were heard, after which the Supervisor declared the hearing closed, decision was reserved.

RESULT: CLOSED [UNANIMOUS]
MOVER: Mary Holtz, Supervisor
SECONDER: James Rogowski, Councilmember
AYES: Holtz, Jaworowicz, Rogowski, Zydel, Markel, Kaznowski
ABSENT: Jeff Swiatek

III. Public Comment Period

IV. Resolutions



1. RESOLUTION 2011-530

Transfer of Funds

Sponsored By: Supervisor Holtz, Councilmember Kaznowski

BE IT RESOLVED, that the following transfer is hereby approved and made a part hereof;

SPECIAL DISTRICTS FUND

FROM:	150.8160.4468	Composting Costs	\$	554.00
	255.8135.4142	Chemicals		4,000.00
TO:	150.8160.4431	Equipment Repairs	\$	554.00
	255.8135.4164	Gas, Oil & Grease		4,000.00

RESULT:	ADOPTED [UNANIMOUS]
MOVER:	Mary Holtz, Supervisor
SECONDER:	Stanley Kaznowski, Councilmember
AYES:	Holtz, Jaworowicz, Rogowski, Zydell, Markel, Kaznowski
ABSENT:	Jeff Swiatek



2. RESOLUTION 2011-531

Warrant

Sponsored By: Supervisor Holtz, Councilmember Kaznowski

BE IT RESOLVED, that the following Vouchers & Warrants submitted to the Town of Cheektowaga prior to September 30, 2011 are hereby approved and made a part hereof;

GENERAL FUND	\$	738,482.94
RISK RETENTION FUND		24,570.41
HUD HOUSING REHABILITATION		8,310.00
SPECIAL DISTRICTS FUND		151,901.58
HIGHWAY FUND		401,434.46
CAPITAL FUND		916,342.87
TRUST & AGENCY FUND		20,498.43
HUD CDBG FUND		7,475.83
PART TOWN FUND		31,342.37
NYS AFFORDABLE HOUSING		22,870.00
		<u>2,323,228.89</u>
	\$	2,323,228.89

RESULT:	ADOPTED [UNANIMOUS]
MOVER:	Mary Holtz, Supervisor
SECONDER:	Stanley Kaznowski, Councilmember
AYES:	Holtz, Jaworowicz, Rogowski, Zydel, Markel, Kaznowski
ABSENT:	Jeff Swiatek



3. RESOLUTION 2011-532

Award of Bid - Cold Milling of Various Town Highways

Sponsored By: Councilmember Kaznowski, Councilmember Zydel

WHEREAS, the contract was awarded for cold milling of various Town highways in the Town of Cheektowaga on March 15, 2010, AND

WHEREAS, the contract allows for an annual renewal and cost adjustment based on the Consumer Price Index (CPI) as of July 31, 2011, AND

WHEREAS, the contractor has submitted the required documentation which has been reviewed and approved, NOW, THEREFORE, BE IT

RESOLVED, that the contract for cold milling of various Town highways in the Town of Cheektowaga for the calendar year 2012 be extended for:

Swank Associated Companies, Inc.
200 Hunt Valley Road
New Kensington, PA 15068

for the unit price of \$0.502 per square yard.

RESULT:	ADOPTED [UNANIMOUS]
MOVER:	Stanley Kaznowski, Councilmember
SECONDER:	Richard Zydel, Councilmember
AYES:	Holtz, Jaworowicz, Rogowski, Zydel, Markel, Kaznowski
ABSENT:	Jeff Swiatek



4. RESOLUTION 2011-533

Award of Bid for Asbestos Surveys for Multiple Properties

Sponsored By: Councilmember Markel, Councilmember Kaznowski

WHEREAS, pursuant to the Unsafe Buildings Law of the Town of Cheektowaga, this Town Board can require that unsafe buildings be either repaired or demolished, and

WHEREAS, the buildings on properties located at 3048 William Street, 74 Hoerner Avenue, 15 Atwood Place, 44A Windwood Court, and 29E Glenwood Court (collectively the "Properties") have experienced extensive deterioration and damage, and Nussbaumer & Clarke, Inc. determined that said buildings are unsafe and recommended that such buildings be demolished and removed; and

WHEREAS, by resolutions adopted August 15, 2011 (Numbers 2011-457, 2011-455, 2011-454, 2011-460, and 2011-459) this Town Board ordered that the buildings on the Properties be either repaired or demolished, and directed that the respective owners or others responsible for the buildings on their respective Properties commence said repair or demolition work within 30 days, and

WHEREAS, more than 30 days have expired and no work has been commenced with respect any of the said Properties; and

WHEREAS, pursuant to the Unsafe Buildings Law, this Town Board can provide for the demolition of an unsafe building and assess the cost of same against the property, and

WHEREAS, prior to the demolition of said Properties, the Town needs to retain a firm to perform an asbestos survey and asbestos abatement plan for same; and

WHEREAS, this Town Board issued a Notice to Bidders (Resolution No. 2011-519) to various asbestos abatement firms and, based on proposals submitted, the Town Attorney has recommended that this Town Board retain Buffalo Environmental Consultants, Inc. d/b/a AFI Environmental to perform said asbestos surveys, specifications and project monitoring work with respect to said Properties for the sum of \$13,990.00 and, if required, a further sum of \$1,975.00 for additional air monitoring and sampling at the sites; NOW, THEREFORE, BE IT

RESOLVED, that this Town Board hereby retains Buffalo Environmental Consultants, Inc. d/b/a AFI Environmental, P.O. Box 4049, Niagara Falls, New York, 14304, to perform the necessary asbestos surveys and abatement work (if necessary) for 3048 William Street, 74 Hoerner Avenue, 15 Atwood Place, 44A Windwood Court, and 29E Glenwood Court at a total cost not to exceed the sum of \$16,095.00 without further Town Board approval; and BE IT FURTHER

RESOLVED, that the Supervisor be and hereby is directed to execute an agreement with Buffalo Environmental Consultants, Inc., d/b/a AFI Environmental for said services, and BE IT FURTHER

RESOLVED, that moneys for said services shall be appropriated from budget line item number 0800-800-0440.

RESULT: **ADOPTED [UNANIMOUS]**
MOVER: Charles Markel, Councilmember
SECONDER: Stanley Kaznowski, Councilmember
AYES: Holtz, Jaworowicz, Rogowski, Zydel, Markel, Kaznowski
ABSENT: Jeff Swiatek



5. RESOLUTION 2011-534

Call for Public Hearing - 2012 Preliminary Ad Valorem Budget

Sponsored By: Holtz, Swiatek, Jaworowicz, Rogowski, Zydel, Markel, Kaznowski

RESOLVED, that this Town Board does hereby prepare and approve as the Preliminary Ad Valorem Budget of this Town for the Fiscal Year beginning on the 1st day of January, 2012, the itemized statement of estimated revenues and expenditures, and also an itemized statement of estimated revenues and expenditures of the Lighting Districts and Consolidated Garbage District, AND, BE IT FURTHER

RESOLVED, that such Preliminary Ad Valorem Budget and the Lighting Districts and Consolidated Garbage District Budgets shall be filed in the Office of the Town Clerk where it shall be available for inspection by any interested person at all reasonable hours, effective October 4, 2011, AND, BE IT FURTHER

RESOLVED, that this Town Board shall meet at 6:00 P.M. on the 18th day of October, 2011, for the purpose of holding a Public Hearing upon such Preliminary Ad Valorem Budget and the Lighting Districts and Consolidated Garbage District budgets, AND, BE IT FURTHER

RESOLVED, that the Town Clerk give Notice of such Public Hearing in the manner provided in Section 108 of the Town Law and that such Notice be published in the CHEEKTOWAGA BEE, the official Town newspaper on October 6, 2011, and post same on the signboard maintained by the Town Clerk.

LEGAL NOTICE

of

PUBLIC HEARING

on

PRELIMINARY AD VALOREM BUDGET

and

LIGHTING DISTRICTS and CONSOLIDATED GARBAGE DISTRICT BUDGETS

NOTICE IS HEREBY GIVEN that the Preliminary Ad Valorem Budget of the Town of Cheektowaga and the Lighting Districts and Consolidated Garbage District Budgets for the Fiscal Year beginning January 1, 2012, has been completed and filed in the Office of the Town Clerk at the Town Hall, corner of Broadway and Union Roads, Cheektowaga, New York where it is available for inspection by any interested person at all reasonable hours, effective October 4, 2011.

FURTHER NOTICE IS HEREBY GIVEN that the Town Board of the Town of

Cheektowaga will meet and review said Preliminary Ad Valorem Budget and the Lighting Districts and Consolidated Garbage District Budgets and hold a Public Hearing thereon at the Town Hall, corner of Broadway and Union Roads, Cheektowaga, New York at 6:00 P.M. on the 18th day of October, 2011 and that at such hearing any person may be heard in favor or against the Preliminary Ad Valorem Budget and the Lighting Districts and Consolidated Garbage District Budget as compiled for or against any item therein contained.

Pursuant to Section 108 of the Town Law, the proposed salaries of the Town Officers are hereby specified as follows:

SUPERVISOR	\$79,140
TOWN CLERK	\$80,960
HIGHWAY SUPERINTENDENT	\$82,150
COUNCILMEMBER(6)	\$20,680
TOWN JUSTICE(2)	\$74,960

BY ORDER OF THE TOWN BOARD OF THE TOWN OF CHEEKTOWAGA, ERIE
COUNTY, NEW YORK

ALICE MAGIERSKI,
TOWN CLERK

Dated: October 3, 2011
Published: October 6, 2011

RESULT:	ADOPTED [UNANIMOUS]
MOVER:	Mary Holtz, Supervisor
SECONDER:	Patricia Jaworowicz, Councilmember
AYES:	Holtz, Jaworowicz, Rogowski, Zydel, Markel, Kaznowski
ABSENT:	Jeff Swiatek



6. RESOLUTION 2011-535

Call for Public Hearing - Benefit Basis Budget

Sponsored By: Holtz, Swiatek, Jaworowicz, Rogowski, Zydel, Markel, Kaznowski

WHEREAS, this Town Board has prepared detailed estimates of the anticipated 2012 revenues and expenditures for every district in which the expenses of the improvement are to be assessed on a benefit basis, AND

WHEREAS, this Town Board has assessed the Special District costs on a benefit basis against the lots or parcels of land against which the improvement was chargeable, AND

WHEREAS, this Town Board had prepared an assessment roll for each district describing each lot of land in the district, the owner thereof, and the assessment levied against it, AND

WHEREAS, this Town Board has filed such estimates and assessment rolls with the Town Clerk, NOW, THEREFORE, BE IT

RESOLVED, that this Town Board shall meet at 6:00 P.M. on the 18th day of October, 2011 for the purpose of holding a Public Hearing upon such estimates and assessment rolls, AND, BE IT FURTHER

RESOLVED, that the Town Clerk give notice of such Public Hearing in the manner provided in Section 239 of the Town Law, and that such notice be published in substantially the following form in the CHEEKTOWAGA BEE, the official Town newspaper on October 6, 2011.

PUBLIC NOTICE

NOTICE IS HEREBY GIVEN that the Town Board of the Town of Cheektowaga, New York has completed its Estimates and Assessment Rolls relating to Special Districts spreading costs on a Benefit Basis and has filed same with the Town Clerk.

NOTICE IS ALSO GIVEN that a public hearing on such Estimates and Assessment Rolls will be held on Tuesday, October 18, 2011 at 6:00 P.M. at the Town Hall, corner of Broadway and Union Roads, at which time the Town Board will meet to hear and consider any objections which shall be made to such Estimates and Assessment Rolls.

BY ORDER OF THE TOWN BOARD OF THE TOWN OF CHEEKTOWAGA,ERIE COUNTY,
NEW YORK

Alice Magierski
Town Clerk

Dated: October 3, 2011
Published: October 6, 2011

RESULT: ADOPTED [UNANIMOUS]

MOVER: Mary Holtz, Supervisor
SECONDER: Patricia Jaworowicz, Councilmember
AYES: Holtz, Jaworowicz, Rogowski, Zydel, Markel, Kaznowski
ABSENT: Jeff Swiatek



7. RESOLUTION 2011-536

Resolution & Order After Public Hearing - Drainage

Sponsored By: Councilmember Kaznowski, Councilmember Zydel

In the Matter

of the

Increase and Improvement of Facilities of the
Town-wide Consolidated Drainage District, in the Town
of Cheektowaga, in the County of Erie, New York, pursuant to
Section 202-b of the Town Law

RESOLUTION AND ORDER AFTER PUBLIC HEARING

WHEREAS, the Town Board of the Town of Cheektowaga (herein called the "Town"), in the County of Erie, New York, on behalf of the Town-wide Consolidated Drainage District (herein called the "District"), has requested the Town Engineer, an engineer duly licensed by the State of New York (herein called the "Engineer"), to prepare a map, plan and report for the increase and improvement of facilities of the District, consisting of storm sewer trunkline improvements to be constructed on Southgate Road, South Century Road, a portion of Cedar Road, and through permanent easement areas acquired from Ken-Vil Associates Limited Partnerships and other related drainage improvements, and any ancillary work in connection therewith, as described in the report prepared by the Engineer, dated September 2011, at the estimated maximum cost of \$900,000; and

WHEREAS, the Town Board adopted an order describing in general terms the proposed increase and improvement of facilities, specifying the estimated cost thereof, and stating the Town Board would meet to hear all persons interested in said increase and improvement of facilities on October 3, 2011 at 6:45 P.M. (Prevailing Time) at the Town Hall, 3301 Broadway, Cheektowaga, New York; and

WHEREAS, a Notice of such public hearing was duly published and posted

pursuant to the provisions of Article 12 of the Town Law; and

WHEREAS, such public hearing was duly held by the Town Board on the 3rd day of October, 2011 at 6:45 P.M. (Prevailing Time) at the Town Hall, 3301 Broadway, Cheektowaga, New York, with considerable discussion on the matter having been had and all persons desiring to be heard having been heard, including those in favor of and those in opposition to said increase and improvement of such facilities; and

WHEREAS, pursuant to the State Environmental Quality Review Act (SEQRA), constituting Article 8 of the Environmental Conservation Law, and 6 N.Y.C.R.R., Regulations Part 617; the Town Board, as lead agency, has given due consideration to the impact that such increase and improvement of facilities may have on the environment and, having reviewed a Short Environmental Assessment Form, the Town Board has determined that such project shall not have any significant effect on the environment and has issued a Negative Declaration for purposes of SEQRA;

Now, therefore, it is hereby

DETERMINED, that it is in the public interest to increase and improve the facilities of the District as hereinabove described, at the estimated maximum cost of \$900,000; and it is hereby

ORDERED, that the facilities of the District shall be so increased and improved and that the Engineer heretofore retained by the Town Board shall prepare plans and specifications and make a careful estimate of the expense for said increase and improvement of such facilities and, with the assistance of the Town Attorney, shall prepare a proposed contract for such increase and improvement of facilities of the District, which plans and specifications, estimate and proposed contract shall be presented to the Town Board as soon as possible; and it is hereby

FURTHER ORDERED, that the expense of said increase and improvement of facilities shall be financed by the issuance of \$900,000 bonds of the Town, and the costs of said increase and improvement of facilities, including payment of principal of and interest on said

bonds, shall be paid by the assessment, levy and collection of assessments upon the several lots and parcels of land within the District which the Town Board shall deem especially benefited by said facilities so much upon and from each as shall be in just proportion to the amount of the benefit which the improvement shall confer upon the same; and it is hereby

FURTHER ORDERED, that the Town Clerk record, or cause to be recorded, a certified copy of this Resolution and Order After Public Hearing in the office of the Clerk of Erie County within ten (10) days after adoption thereof.

DATED: October 3, 2011

(SEAL)

TOWN BOARD OF THE TOWN OF CHEEKTOWAGA

RESULT:	ADOPTED [UNANIMOUS]
MOVER:	Stanley Kaznowski, Councilmember
SECONDER:	Richard Zydell, Councilmember
AYES:	Holtz, Jaworowicz, Rogowski, Zydell, Markel, Kaznowski
ABSENT:	Jeff Swiatek



8. RESOLUTION 2011-537

Bond Resolution - Southgate Drainage

Sponsored By: Councilmember Kaznowski, Councilmember Zydel

BOND RESOLUTION OF THE TOWN OF CHEEKTOWAGA, NEW YORK, ADOPTED OCTOBER 3, 2011, APPROPRIATING \$900,000 FOR THE INCREASE AND IMPROVEMENT OF FACILITIES OF THE TOWN-WIDE CONSOLIDATED DRAINAGE DISTRICT, AND AUTHORIZING THE ISSUANCE OF \$900,000 SERIAL BONDS OF SAID TOWN TO FINANCE SAID APPROPRIATION

Recital

WHEREAS, following preparation of a map, plan and report and an estimate of cost for the increase and improvement of facilities of Town-wide Consolidated Drainage District (herein called the "District"), in the Town of Cheektowaga (herein called the "Town"), in the County of Erie, New York, and after a public hearing duly called and held, the Town Board of the Town determined that it is in the public interest to increase and improve the facilities of the District, as described herein, and ordered that such facilities be so increased and improved;

Now, therefore, be it

RESOLVED BY THE TOWN BOARD OF THE TOWN OF CHEEKTOWAGA, IN THE COUNTY OF ERIE, NEW YORK (by the favorable vote of not less than two-thirds of all the members of said Board) AS FOLLOWS:

Section 1. The Town hereby appropriates the amount of \$900,000 for the increase and improvement of facilities of the District, consisting of storm sewer trunkline improvements to be constructed on Southgate Road, South Century Road, a portion of Cedar Road, and through permanent easement areas acquired from Ken-Vil Associates Limited

Partnerships and other related drainage improvements, and any ancillary work in connection therewith, as described in the report prepared by the Town Engineer, dated September 2011. The estimated maximum cost thereof, including preliminary costs and costs incidental thereto and the financing thereof, is \$900,000. The plan of financing includes the issuance of \$900,000 bonds of the Town to finance said appropriation and by the assessment, levy and collection of assessments upon the several lots and parcels of land within the District which the Town Board shall deem especially benefited by said facilities so much upon and from each as shall be in just proportion to the amount of the benefit which the improvement shall confer upon the same.

Section 2. Bonds of the Town are hereby authorized to be issued in the principal amount of \$900,000 pursuant to the provisions of the Local Finance Law, constituting Chapter 33-a of the Consolidated Laws of the State of New York (herein called the "Law"), to finance said appropriation.

Section 3. The following additional matters are hereby determined and stated:

(a) The period of probable usefulness of the object or purpose for which said bonds are authorized to be issued, within the limitations of Section 11.00 a. 4 of the Law, is forty (40) years.

(b) The proceeds of the bonds herein authorized and any bond anticipation notes issued in anticipation of said bonds may be applied to reimburse the Town for expenditures made after the effective date of this resolution, for the purpose for which said bonds are authorized. The foregoing statement of intent with respect to reimbursement is made in conformity with Treasury Regulation Section 1.150-2 of the United States Treasury Department.

(c) The proposed maturity of the serial bonds authorized by this resolution will exceed five (5) years.

Section 4. Each of the bonds authorized by this resolution and any bond anticipation notes issued in anticipation of said bonds shall contain the recital of validity prescribed by Section 52.00 of the Law and said bonds and any notes issued in anticipation

said bonds shall be general obligations of the Town, payable as to both principal and interest by a general tax upon all the taxable real property within the Town. The faith and credit of the Town are hereby irrevocably pledged to the punctual payment of the principal of and interest on said bonds and any notes issued in anticipation of the sale of said bonds, and provision shall be made annually in the budget of the Town by appropriation for (a) the amortization and redemption of the bonds and any notes issued in anticipation thereof to mature in such year and (b) the payment of interest to be due and payable in such year.

Section 5. Subject to the provisions of this resolution and of the Law and pursuant to the provisions of Section 21.00 relative to the authorization of the issuance of bonds with substantially level or declining annual debt service, Section 30.00 relative to the authorization of the issuance of bond anticipation notes and Section 50.00 and Sections 56.00 to 60.00 and 168.00 of the Law, the powers and duties of the Town Board relative to authorizing bond anticipation notes and prescribing the terms, form and contents and as to the sale and issuance of the bonds herein authorized, and the renewals of said bond anticipation notes, and relative to executing contracts for credit enhancements and providing for substantially level or declining annual debt service, are hereby delegated to the Supervisor, the chief fiscal officer of the Town.

Section 6. The validity of the bonds authorized by this resolution, and of any notes issued in anticipation of said bonds, may be contested only if:

- (a) such obligations are authorized for an object or purpose for which the Town is not authorized to expend money, or
- (b) the provisions of law which should be complied with at the date of the publication of such resolution, or a summary thereof, are not substantially complied with, and

an action, suit or proceeding contesting such validity is commenced within twenty days after the date of such publication, or

- (c) such obligations are authorized in violation of the provisions of the constitution.

Section 7. This resolution shall take effect immediately and the Town Clerk is

hereby authorized and directed to publish the foregoing bond resolution, in summary, in the "Cheektowaga Bee," a newspaper having a general circulation in said Town, which newspaper is hereby designated as the official newspaper of the Town for such publication, together with the Town Clerk's statutory notice in the form prescribed by Section 81.00 of the Local Finance Law of the State of New York.

RESULT:	ADOPTED [UNANIMOUS]
MOVER:	Stanley Kaznowski, Councilmember
SECONDER:	Richard Zydell, Councilmember
AYES:	Holtz, Jaworowicz, Rogowski, Zydell, Markel, Kaznowski
ABSENT:	Jeff Swiatek



9. RESOLUTION 2011-538

Notice to Bidders - Grouting Sanitary Sewers

Sponsored By: Councilmember Kaznowski, Councilmember Zydel

WHEREAS, it is in order that bids be advertised for the furnishing of equipment and operators for the grouting, cleaning and televising of various sanitary sewers in the Town of Cheektowaga, NOW, THEREFORE, BE IT

RESOLVED, that this request be granted and that the Town Clerk be directed to publish a Notice to Bidders for the furnishing of equipment and operators for the grouting, cleaning and televising of various sanitary sewers for a one (1) year contract covering October 2011 to October 2012, said notice to be published in the CHEEKTOWAGA BEE, AND, BE IT FURTHER

RESOLVED, that sealed bids will be received on the 12th day of October, 2011 at 11:00 am, at a public bid opening to be held in the Council Chambers at the Cheektowaga Town Hall.

NOTICE TO BIDDERS

Sealed proposals will be received and considered by the Town Board of the Town of Cheektowaga on October 12, 2011 at 11:00 am at the Town Hall, corner of Broadway and Union Roads, for the furnishing of equipment and operators for the grouting, cleaning and televising of various sanitary sewers in the Town of Cheektowaga for a one (1) year contract covering October 2011 to October 2012.

Information for bidders and specifications may be obtained from the Town Clerk at her office in said Town Hall.

Proposals shall be submitted in a sealed envelope plainly marked on the outside "Bid for Furnishing of Equipment and Operators for the Grouting, Cleaning and Televising of Various Sanitary Sewers" and submitted to the Town Clerk prior to bid opening.

No bidder may withdraw his bid within forty-five (45) days after the actual date of the opening thereof.

The Town Board reserves the right to consider informal any bid not prepared and submitted in accordance with the provisions of the specifications and contract documents, and may waive any informalities, make an award to other than the low bidder, should it be in the best interest of the Town, or reject any or all bids.

Each proposal must be accompanied by a certified check for a sum equal to five percent (5%) of the amount of the bid, payable to the Town of Cheektowaga, New York, or bond with sufficient sureties to be approved by the attorney for the Town of Cheektowaga, New York.

The successful bidder will be required to furnish a Performance Bond acceptable to

the Owner in an amount equal to the contract award.

BY ORDER OF THE TOWN BOARD OF THE TOWN OF CHEEKTOWAGA, ERIE COUNTY, NEW YORK.

Alice Magierski, Town Clerk

DATED: October 3, 2011

RESULT:	ADOPTED [UNANIMOUS]
MOVER:	Stanley Kaznowski, Councilmember
SECONDER:	Richard Zydel, Councilmember
AYES:	Holtz, Jaworowicz, Rogowski, Zydel, Markel, Kaznowski
ABSENT:	Jeff Swiatek



10. RESOLUTION 2011-539

Notice to Bidders - Emergency Snow Removal

Sponsored By: Supervisor Holtz, Councilmember Markel

WHEREAS, it is in order that bids be advertised for Equipment and Operators for Emergency Snow Removal for the 2011-2012 winter season, NOW, THEREFORE, BE IT

RESOLVED, that the Town Clerk be directed to publish a Notice to Bidders for Equipment and Operators for Emergency Snow Removal for the 2011-2012 winter season, said notice to be published in the CHEEKTOWAGA BEE, AND, BE IT FURTHER

RESOLVED, that sealed bids will be received and opened on the 19th day of October, 2011 at 11:00 am at a public bid opening to be held in the Council Chambers in the Cheektowaga Town Hall.

NOTICE TO BIDDERS

Sealed proposals will be received and considered by the Town Board of the Town of Cheektowaga on October 19, 2011, at 11:00 am, at the Town Hall, corner of Broadway and Union Roads, Cheektowaga, New York, for the furnishing of equipment and operators for the removal of snow from highways situated in the Town in the event of a snow emergency during the 2011-2012 winter season.

Information for bidders and specifications may be obtained from the Office of the Town Clerk in the Cheektowaga Town Hall, located at Broadway and Union Roads, Cheektowaga, New York 14227 between the hours of 9:00 am and 4:30 pm.

All bids must be filed with the Town Clerk's Office, Town Hall, Broadway & Union Roads, Cheektowaga, New York 14227 prior to the time of the bid opening scheduled for Wednesday, October 19, 2011 at 11:00 am in the Town Hall Council Chambers.

Proposals shall be submitted in a sealed envelope, plainly marked on the outside "Bid for Furnishing of Equipment and Operators for Emergency Snow Removal for the 2011-2012 Winter Season" and submitted to the Town Clerk prior to bid opening.

No bidder may withdraw his bid within forty-five (45) days after the actual date of the opening thereof.

The Town Board reserves the right to consider informal any bid not prepared and submitted in accordance with the provisions of the specifications and contract documents, and may waive any informality, make an award to other than the low bidder, should it be in the best interest of the Town, or reject any and all bids.

Alice Magierski
Town Clerk

DATED: October 3, 2011

RESULT: ADOPTED [UNANIMOUS]

MOVER: Mary Holtz, Supervisor
SECONDER: Charles Markel, Councilmember
AYES: Holtz, Jaworowicz, Rogowski, Zydel, Markel, Kaznowski
ABSENT: Jeff Swiatek



11. RESOLUTION 2011-540

Approve Purchase of Rotary Mower for the Facilities Department

Sponsored By: Councilmember Rogowski, Councilmember Zydel

WHEREAS, the Director of the Facilities Department is in need of a rotary mower for use in maintaining Town Parks, and

WHEREAS, the purchase of such equipment is available through S.V. Moffett Turf Equipment as per New York State Contract #PC64364, and

WHEREAS, moneys have been appropriated in the Facilities Department budget for the purchase said line 100-7110-2304, and

WHEREAS, Section 103-b of the General Municipal Law authorizes the Town to enter into a purchase agreement for machinery, equipment or apparatus, and

WHEREAS, the proposed Purchase Agreement with S.V. Moffett Turf Equipment contains the language required by Section 103-b of the General Municipal Law and otherwise complies with New York State law, NOW, THEREFORE BE IT

RESOLVED, that this Town Board hereby approves the purchase of one (1) Jacobsen Mower HR-9016 Turbo Wide-Area Rotary Mower for use by the Facilities Department as per the terms of it Municipal Agreement at the cost of \$72,721.20, and BE IT FURTHER

RESOLVED, that the Supervisor, on behalf of the Town, be and hereby is authorized and directed to execute the purchase agreement and all other documents necessary for the purchase of the above referenced equipment, subject, however, to approval by the Town Attorney, and BE IT FURTHER

RESOLVED, that funds for payments shall be appropriated from the Facilities Department budget line 100-7110-2304. Reference Purchase Order 11797.

RESULT:	ADOPTED [UNANIMOUS]
MOVER:	James Rogowski, Councilmember
SECONDER:	Richard Zydel, Councilmember
AYES:	Holtz, Jaworowicz, Rogowski, Zydel, Markel, Kaznowski
ABSENT:	Jeff Swiatek



12. RESOLUTION 2011-541

Designation of Halloween Night

Sponsored By: Supervisor Holtz, Councilmember Jaworowicz

WHEREAS, the children of our community are entitled to the fun and excitement associated with "Halloween Night", including going from door-to-door in their immediate neighborhoods with their happy challenges of trick-or-treat; AND

WHEREAS, it would appear that parents generally favor the early evening hours, since it tends to limit participation to the younger children, for whom the observance was originally intended and thereby discourages interference and disruption by the very small percentage of older children, who under cover of darkness and with their identities concealed and costumes, might otherwise spoil the fun for the smaller children, NOW, THEREFORE, BE IT

RESOLVED, that Monday, October 31, 2011 shall be known as "Halloween Night" in the Town of Cheektowaga, and that the Town Board ask both children and their parents to cooperate in limiting the time of "trick-or-treating" activities to the period between 6:00 P.M. and 8:00 P.M. We further ask that, whenever possible, parents of the very young insure that they or other responsible adults accompany them, and to cooperate in making this a happy occasion for all youngsters by keeping their porch or exterior lights on.

"DESIGNATION OF HALLOWEEN NIGHT"

BE IT RESOLVED, that Monday, October 31, 2011 be designated as "HALLOWEEN NIGHT" in the Town of Cheektowaga.

The time of "trick-or-treating" activities will be between 6:00 P.M. and 8:00 P.M.

We encourage all householders to cooperate in making this a happy occasion for all youngsters by keeping their porch or exterior lights on.

HAPPY HALLOWEEN TO ALL!

BY ORDER OF THE TOWN BOARD
OF THE TOWN OF CHEEKTOWAGA,
ERIE COUNTY, NEW YORK

Alice Magierski, Town Clerk

RESULT:	ADOPTED [UNANIMOUS]
MOVER:	Mary Holtz, Supervisor
SECONDER:	Patricia Jaworowicz, Councilmember
AYES:	Holtz, Jaworowicz, Rogowski, Zydel, Markel, Kaznowski
ABSENT:	Jeff Swiatek



13. RESOLUTION 2011-542

Bonfire-Cleveland Hill/105 Mapleview Road

Sponsored By: Councilmember Markel, Councilmember Zydel

WHEREAS, pursuant to the Open Burning Law of the Town of Cheektowaga, the Fire Inspector reviews various applications for open fires and open burning and renders his recommendation concerning the fire safety and impact to the general public of such application, AND

WHEREAS, the Town Board, pursuant to the Open Burning Law of the Town of Cheektowaga, is designated the Approval Agency, AND

WHEREAS, since the Town Board is the Approval Agency, it must affirm, modify or reject any recommendations or permits submitted to it by the Town Fire Inspector, AND

WHEREAS, an application for a permit was submitted by the Cleveland Hill Union Free School District to conduct a open fire on October 14, 2011 on the property located at 105 Mapleview Road, Cheektowaga, New York AND

WHEREAS, the applicant intends to maintain a small bonfire with the assistance of the Cleveland Hill Fire Department in conjunction with summer youth activities, AND

WHEREAS, the Fire Inspector has received this application and finds that all requirements have been met, and that this application is in compliance with conditions and requirement of the Town of Cheektowaga Fire Prevention Code and the Open Burning Law. He requests the Town Board approve issuance of a permit, AND

WHEREAS, this Town Board has reviewed the application submitted by the Cleveland Hill Union Free School District and the recommendations of the Fire Inspector, NOW, THEREFORE, BE IT

RESOLVED, that this Town Board, authorizes the Fire Inspector to issue such permit.

RESULT:	ADOPTED [UNANIMOUS]
MOVER:	Charles Markel, Councilmember
SECONDER:	Richard Zydel, Councilmember
AYES:	Holtz, Jaworowicz, Rogowski, Zydel, Markel, Kaznowski
ABSENT:	Jeff Swiatek



14. RESOLUTION 2011-543

Bonfire-Maryvale High School/1050 Maryvale Drive

Sponsored By: Councilmember Markel, Councilmember Zydel

WHEREAS, pursuant to the Open Burning Law of the Town of Cheektowaga, the Fire Inspector reviews various applications for open fires and open burning and renders his recommendation concerning the fire safety and impact to the general public of such application, AND

WHEREAS, the Town Board, pursuant to the Open Burning Law of the Town of Cheektowaga, is designated the Approval Agency, AND

WHEREAS, since the Town Board is the Approval Agency, it must affirm, modify or reject any recommendations or permits submitted to it by the Town Fire Inspector, AND

WHEREAS, an application for a permit was submitted by the Maryvale School to conduct a open fire on October 12, 2011 on the property located at 1050 Maryvale Drive, Cheektowaga, New York AND

WHEREAS, the applicant intends to maintain a small bonfire with the assistance of the U-Crest Fire Department in conjunction with summer youth activities, AND

WHEREAS, the Fire Inspector has received this application and finds that all requirements have been met. And that this application is in compliance with conditions and requirement of the Town of Cheektowaga Fire Prevention Code and the Open Burning Law. He requests the Town Board approve issuance of a permit, AND

WHEREAS, this Town Board has reviewed the application submitted by the Maryvale School and the recommendations of the Fire Inspector, NOW, THEREFORE, BE IT

RESOLVED, that this Town Board, authorizes the Fire Inspector to issue such permit.

RESULT:	ADOPTED [UNANIMOUS]
MOVER:	Charles Markel, Councilmember
SECONDER:	Richard Zydel, Councilmember
AYES:	Holtz, Jaworowicz, Rogowski, Zydel, Markel, Kaznowski
ABSENT:	Jeff Swiatek



15. RESOLUTION 2011-544

Demolition of Accessory Structure/20 Mafalda Drive

Sponsored By: Councilmember Markel, Councilmember Kaznowski

WHEREAS, Town of Cheektowaga Law for the Administration and Enforcement of the Codes of New York State; and the Property Maintenance Code of New York State require that all vacant structures and premises shall be maintained in clean, safe, secure and sanitary conditions so as not to cause a blighting problem or adversely affect the public health or safety and all nuisances abated, AND

WHEREAS, the Town of Cheektowaga has received notification of an unsafe structure and premises located at 20 Mafalda Drive, Cheektowaga, New York SBL# 91.05-1-46 that is a danger to the safety of others, and records kept by the Assessors Office identify Mary L. Packer Living Trust, Attn: Mary L. Packer Trustee, 20 Mafalda Drive, Cheektowaga, New York 14215, as the owner AND

WHEREAS, an inspection of such premises was conducted at 20 Mafalda Drive, by the Housing and Neighborhood Preservation Office, AND

WHEREAS, such inspection found the premises to be deteriorated, vacant, a hazard, and a danger to the safety and well being of others, AND

WHEREAS, the Town of Cheektowaga Housing and Neighborhood Preservation Office properly notified the property owner in accordance with the Town of Cheektowaga Law for the Administration and Enforcement of the Codes of New York State, and the owner failed to take actions to safeguard the premises, AND

WHEREAS, these conditions require the Town of Cheektowaga Housing and Neighborhood Preservation Office to take immediate steps to safeguard the premises to protect the health and safety of others and abate all nuisances, NOW, THEREFORE BE IT

RESOLVED, that pursuant to Section 70-7A.(5) and Section 70-8 of the Town of Cheektowaga Law for the Administration and Enforcement of the Codes of New York State that the vacant structure premises be safeguarded and all nuisances abated; and all costs incurred be assessed against the property hereinbefore described.

RESULT:	ADOPTED [UNANIMOUS]
MOVER:	Charles Markel, Councilmember
SECONDER:	Stanley Kaznowski, Councilmember
AYES:	Holtz, Jaworowicz, Rogowski, Zydel, Markel, Kaznowski
ABSENT:	Jeff Swiatek



16. RESOLUTION 2011-545

Unsafe-Unsecured / 257 Chapel Avenue

Sponsored By: Councilmember Markel, Councilmember Kaznowski

WHEREAS, Town of Cheektowaga Law for the Administration and Enforcement of the Codes of New York State; and the Property Maintenance Code of New York State require that all vacant structures and premises shall be maintained in clean, safe, secure and sanitary conditions so as not to cause a blighting problem or adversely affect the public health or safety and all nuisances abated, AND

WHEREAS, the Town of Cheektowaga has received notification of an unsafe structure and premises located at 257 Chapel Avenue, Cheektowaga, New York SBL# 92.17-2-17 that is a danger to the safety of others, and records kept by the Assessors Office identify James J. Gauthier, 143 Claudette Court, Cheektowaga, New York 14225 and Gail K. James, 257 Chapel Avenue, Cheektowaga, New York 14225, as the owner AND

WHEREAS, an inspection of such premises was conducted at 257 Chapel Avenue, by the Housing and Neighborhood Preservation Office, AND

WHEREAS, such inspection found the premises to be deteriorated, vacant, a hazard, and a danger to the safety and well being of others, AND

WHEREAS, the Town of Cheektowaga Housing and Neighborhood Preservation Office properly notified the property owner in accordance with the Town of Cheektowaga Law for the Administration and Enforcement of the Codes of New York State, and the owner failed to take actions to safeguard the premises, AND

WHEREAS, these conditions require the Town of Cheektowaga Housing and Neighborhood Preservation Office to take immediate steps to safeguard the premises to protect the health and safety of others and abate all nuisances, NOW, THEREFORE BE IT

RESOLVED, that pursuant to Section 70-7A.(5) and Section 70-8 of the Town of Cheektowaga Law for the Administration and Enforcement of the Codes of New York State that the vacant structure premises be safeguarded and all nuisances abated; and all costs incurred be assessed against the property hereinbefore described.

RESULT:	ADOPTED [UNANIMOUS]
MOVER:	Charles Markel, Councilmember
SECONDER:	Stanley Kaznowski, Councilmember
AYES:	Holtz, Jaworowicz, Rogowski, Zydel, Markel, Kaznowski
ABSENT:	Jeff Swiatek



17. RESOLUTION 2011-546

Unsafe-Unsecured/37 Ivanhoe Road

Sponsored By: Councilmember Markel, Councilmember Kaznowski

WHEREAS, Town of Cheektowaga Law for the Administration and Enforcement of the Codes of New York State; and the Property Maintenance Code of New York State require that all vacant structures and premises shall be maintained in clean, safe, secure and sanitary conditions so as not to cause a blighting problem or adversely affect the public health or safety and all nuisances abated, AND

WHEREAS, the Town of Cheektowaga has received notification of an unsafe structure and premises located at 37 Ivanhoe Road, Cheektowaga, New York SBL# 90.76-3-39 that is a danger to the safety of others, and records kept by the Assessors Office identify Margaret M. Hilgers, 114 Noel Drive, Buffalo, New York 14221, as the owner AND

WHEREAS, an inspection of such premises was conducted at 37 Ivanhoe Road, by the Housing and Neighborhood Preservation Office, AND

WHEREAS, such inspection found the premises to be deteriorated, vacant, a hazard, and a danger to the safety and well being of others, AND

WHEREAS, the Town of Cheektowaga Housing and Neighborhood Preservation Office properly notified the property owner in accordance with the Town of Cheektowaga Law for the Administration and Enforcement of the Codes of New York State, and the owner failed to take actions to safeguard the premises, AND

WHEREAS, these conditions require the Town of Cheektowaga Housing and Neighborhood Preservation Office to take immediate steps to safeguard the premises to protect the health and safety of others and abate all nuisances, NOW, THEREFORE BE IT

RESOLVED, that pursuant to Section 70-7A.(5) and Section 70-8 of the Town of Cheektowaga Law for the Administration and Enforcement of the Codes of New York State that the vacant structure premises be safeguarded and all nuisances abated; and all costs incurred be assessed against the property hereinbefore described.

RESULT:	ADOPTED [UNANIMOUS]
MOVER:	Charles Markel, Councilmember
SECONDER:	Stanley Kaznowski, Councilmember
AYES:	Holtz, Jaworowicz, Rogowski, Zydell, Markel, Kaznowski
ABSENT:	Jeff Swiatek



18. RESOLUTION 2011-547

Youth & Recreation Terminations

Sponsored By: Councilmember Zydel, Councilmember Rogowski

BE IT RESOLVED that the individuals listed below be and herby are terminated in the Department of Youth & Recreational Services, effective as indicated:

Jillian Adamczak	8/26/2011	14211
Brad Agen	8/31/2011	14227
Alexis Blachowski	8/26/2011	14225
Lauren Boehm	8/26/2011	14225
Lauren Bujnicki	8/26/2011	14227
Charlie Jane Clark	8/26/2011	14215
Meghan Eckle	8/26/2011	14225
Meggan Empric	8/26/2011	14215
Mark Hannon	8/26/2011	14225
Valerie Herman	8/26/2011	14225
Shannon Kelly	8/26/2011	14227
Stephen Kelly	8/26/2011	14211
Julie Laffrado	8/26/2011	14225
Lori Majewski	8/26/2011	14227
Joseph Malicki	8/26/2011	14043
Tracey Marlinski	8/26/2011	14227
Brandon Rappold	8/26/2011	14225
Carolyn Reczek	8/26/2011	14227
Kristen Schugardt	8/26/2011	14043
Robyn Stanley	8/26/2011	14225
Robert Strauss	8/26/2011	14043
Andrew Swiat	9/15/2011	14227
Lauren Szydlowski	8/26/2011	14227
Joshua Tedesco	8/26/2011	14227
Theresa Tripi	8/26/2011	14227
Barbara Walters	5/18/2011	14227
Daniel Zogaria	8/24/2011	14206

Motion by Councilmember Rogowski; Seconded by Supervisor Holtz; to waive the reading of names for the following three (3) resolutions: 2011-547; 2011-548 and 2011-549. Motion Carried.

RESULT: ADOPTED [UNANIMOUS]
MOVER: Richard Zydel, Councilmember
SECONDER: James Rogowski, Councilmember
AYES: Holtz, Jaworowicz, Rogowski, Zydel, Markel, Kaznowski
ABSENT: Jeff Swiatek



19. RESOLUTION 2011-548

Youth & Recreation Hiring/Transfers

Sponsored By: Councilmember Zydel, Councilmember Rogowski

BE IT RESOLVED that the individuals listed below be and hereby are hired and/or transferred, as indicated, in the Department of Youth & Recreational Services, effective immediately:

Recreation Instructor - 7140.1630 - \$9.25 - Regular Part-time
Susan Mayle 14215

Recreation Attendant - 7140.1664 - \$9.75 - Regular Part-time
Kathy Carnall 14225
Mary Beth Lunghino 14206

Recreation Attendant - 7140.1664 - \$10.80 - Regular Part-time
Sandra Suwalski 14206

Recreation Attendant - 7140.1664 - \$11.05 - Regular Part-time
Ann Sheldon 14227
Michele Radlich 14225

Recreation Attendant - 7140.1664 - \$11.55 - Regular Part-time
Nancy Fumerelle 14227

Recreation Attendant - 7140.1664 - \$13.30 - Regular Part-time
Laila Desjardins 14227

Recreation Instructor - 7140.1664 - \$9.00 - Regular Part-time
Joelle Gretch 14043

Recreation Aide - 7310.1803 - \$7.25 - Part-time
Nicholas Hawley 14227

From Camp Flamingo - 7310.1810 to Adapted Recreation Program - 7310.1803
Regular Part-time - Effective immediately

Martin Acevedo
Denise Atkisson
Nicole Habermehl
Jennifer Laffrado
Amanda Langa
Kelly Mayer
Amy McMahon
Kristen Stadelmeyer

From Camp Flamingo - 7310.1810 to Adapted Recreation Program - 7310.1803
Part-time - Effective immediately

Ashley Carney
Rebecca Langa

Anthony Pachetti
Nicole Putland

From Camp Crabapple - 7310.1802 to Adapted Recreation Program - 7310.1803
Regular Part-time - Effective immediately

Bryan Haxton
DeYonca Porter
Amy Wroblewski

From Camp JI-IK-DO-WAH-GAH - 7310.1801 to Adapted Recreation Program - 7310.1803
Regular Part-time - Effective immediately

Alex Ladowski
Melissa Rogers
Maribeth Stadelmeyer
Jessica Szyka

From Camp JI-IK-DO-WAH-GAH - 7310.1801 to Adapted Recreation Program - 7310.1803
Part-time - Effective immediately

Jenna Soldaczewski

From Camp Crabapple- 7310.1802 to Adapted Recreation Program - 7310.1803
Part-time - Effective immediately

Cerene Usinski

From Teen Club - 7310.1814 to Adapted Recreation Program - 7310.1803
Regular Part-time - Effective immediately

Casey Hawley
Jennifer Zelasko

FROM SEASONAL TO REGULAR PART-TIME

From Camp Crabapple - 7310.1802 to Adapted Recreation Program - 7310.1803
Regular Part-time - Effective immediately

Merissa Ciesielski
Holly Sobkowiak

From Camp JI-IK-DO-WAH-GAH - 7310.1801 to Adapted Recreation Program - 7310.1803
Regular Part-time - Effective immediately

Emalee Danner
Allison Herman

From Camp Flamingo - 7310.1810 to Adapted Recreation Program - 7310.1803
Regular Part-time - Effective immediately

Joshua Fruchtel
Ann Marie Heide
Alysia Kent
Rebecca Szyjka
Nicole Wyzkowski

From Camp Dartwood - 7140.1632 to Adapted Recreation Program - 7310.1803
Regular Part-time - Effective immediately

Jacquelyn Rieck
Tabitha Slachciak

RESULT: **ADOPTED [UNANIMOUS]**
MOVER: Richard Zydell, Councilmember
SECONDER: James Rogowski, Councilmember
AYES: Holtz, Jaworowicz, Rogowski, Zydell, Markel, Kaznowski
ABSENT: Jeff Swiatek



20. RESOLUTION 2011-549

Hiring/Termination of Part-Time/Seasonal Employees

Sponsored By: Supervisor Holtz, Councilmember Jaworowicz

BE IT RESOLVED, that the following individual be and hereby is hired as a **SEASONAL EMPLOYEE**, not to exceed five (5) months in a calendar year, in the departments listed and in compliance with Civil Service Laws and Regulations as well as the provisions of the Town's collective bargaining agreement between the Town of Cheektowaga and the Town of Cheektowaga Employees Association:

FACILITIES DEPARTMENT (Buildings & Grounds Division) Laborer \$8.00/hour effective 10/4/11
Aaron Gorski, Cheektowaga, New York

BE IT RESOLVED, that the following individuals be and hereby are hired as **PART-TIME EMPLOYEES** in the departments listed, not to exceed nineteen (19) hours on a weekly basis, in compliance with Civil Service Laws and Regulations as well as the provisions of the Town's collective bargaining agreement between the Town of Cheektowaga and the Town of Cheektowaga Employees Association:

SANITATION DEPARTMENT Laborer \$8.00/hour effective 9/20/11
Norman D. Nuessle, Cheektowaga, New York

POLICE DEPARTMENT Detention Officer \$14.00/hour effective 10/3/11
Janie L. Ross, Cheektowaga, New York

BE IT RESOLVED, that the following seasonal and/or part-time employees be and hereby are terminated as listed:

SANITATION DEPARTMENT
Robert F. Vesona effective 9/17/11
Walter W. Szafraniec effective 9/17/11
Tyler Schaf effective 9/17/11
Joshua R. Loucks effective 9/17/11

POLICE DEPARTMENT
Lindsay R. Kowalewski effective 9/4/11

FACILITIES DEPARTMENT
Michael Lawicki effective 9/21/11
David Cunningham effective 9/18/11
Joseph Boccio effective 9/26/11
Adam Paradowski effective 10/1/11

RESULT: ADOPTED [UNANIMOUS]

MOVER: Mary Holtz, Supervisor
SECONDER: Patricia Jaworowicz, Councilmember
AYES: Holtz, Jaworowicz, Rogowski, Zydel, Markel, Kaznowski
ABSENT: Jeff Swiatek



21. RESOLUTION 2011-550

Appointment of Laborer (Labor/Permanent) Highway Department/Vincent A. Cename

Sponsored By: Supervisor Holtz, Councilmember Markel

WHEREAS, a vacancy exists in the title of Laborer in the Highway Department; AND

WHEREAS, notice of such vacancy has been posted in accordance with the provisions of the Town's collective bargaining agreement with the Town of Cheektowaga Employees Association; AND

WHEREAS, no full-time bargaining unit member bid on said vacancy; AND

WHEREAS, Vincent A. Cename, applied for said vacancy and meets the qualifications for appointment; NOW, THEREFORE, BE IT

RESOLVED, that Vincent A. Cename of Cheektowaga, New York, be and hereby is appointed to the position of Laborer in the Highway Department in accordance with the terms and conditions of the Town's collective bargaining agreement with the Town of Cheektowaga Employees Association effective October 4, 2011.

RESULT:	ADOPTED [UNANIMOUS]
MOVER:	Mary Holtz, Supervisor
SECONDER:	Charles Markel, Councilmember
AYES:	Holtz, Jaworowicz, Rogowski, Zydell, Markel, Kaznowski
ABSENT:	Jeff Swiatek



22. RESOLUTION 2011-551

Travel Authorization Youth and Recreation/Program Coordinator Jillian Gorman-King

Sponsored By: Supervisor Holtz, Councilmember Rogowski

WHEREAS, the Association of New York State Youth Bureaus and Boards Directors Training and Annual Conference is being held October 26 through October 28, 2011 in Albany, New York; AND

WHEREAS, Program Coordinator Jillian Gorman-King has requested authorization to attend said training and annual conference; AND

WHEREAS, Executive Director (Youth Board) Ellen Fischer has submitted a request for travel authorization along with the proper paperwork in a timely manner; AND

WHEREAS, the total cost to the Town shall not exceed \$550; AND

WHEREAS, these expenses have been budgeted by the Youth and Recreational Services Department; NOW, THEREFORE, BE IT

RESOLVED, that Program Coordinator Jillian Gorman-King be and hereby is authorized to attend the Association of New York State Youth Bureaus and Boards Directors Training and Annual Conference being held October 26 through October 28, 2011 in Albany, New York.

RESULT:	ADOPTED [UNANIMOUS]
MOVER:	Mary Holtz, Supervisor
SECONDER:	James Rogowski, Councilmember
AYES:	Holtz, Jaworowicz, Rogowski, Zydell, Markel, Kaznowski
ABSENT:	Jeff Swiatek



23. RESOLUTION 2011-552

Travel Authorization Police Department/Police Officers Christopher Geelan, David Vogel and David Filipski

Sponsored By: Councilmember Jaworowicz, Councilmember Rogowski

WHEREAS, the Proactive Drug Interdiction and Vehicle Concealment course is being held October 17 through October 18, 2011 at the Erie County Fire Training Tower; AND

WHEREAS, Police Officers Christopher Geelan, David Vogel and David Filipski have requested authorization to attend said course; AND

WHEREAS, Police Chief David Zack has submitted a request for travel authorization along with the proper paperwork in a timely manner; AND

WHEREAS, the total cost to the Town shall not exceed \$837; AND

WHEREAS, these expenses have been budgeted by the Police Department; NOW, THEREFORE, BE IT

RESOLVED, that Police Officers Christopher Geelan, David Vogel and David Filipski be and hereby are authorized to attend the Proactive Drug Interdiction and Vehicle Concealment course being held October 17 through October 18, 2011 at the Erie County Fire Training Tower.

RESULT:	ADOPTED [UNANIMOUS]
MOVER:	Patricia Jaworowicz, Councilmember
SECONDER:	James Rogowski, Councilmember
AYES:	Holtz, Jaworowicz, Rogowski, Zydell, Markel, Kaznowski
ABSENT:	Jeff Swiatek

V. Communications

A. Departmental Communications

1. Town of Cheektowaga 2012 Tentative Budget
2. Building Permits - September 2011
3. Minutes: Cheektowaga Conservation Advisory Council - September 1, 2011
4. Minutes: Cheektowaga Planning Board - September 8Th, 2011
5. Minutes: Cheektowaga Public Library - Board of Trustees - September 21, 2011

B. General Communications

1. Summons & Complaint: Nadiyah Whitaken, Individually and as Parent and NG of Takio Loman, Infant Vs. Town of Cheektowaga
2. Notice of Claim: Maurice Dark Vs. Town of Cheektowaga
3. Notice of Claim: Helen A. Derenda Vs. Town of Cheektowaga
4. Notice of Claim: Megan Kane Vs. Town of Cheektowaga
5. Notice of Claim: Karl Malkowski Vs. Town of Cheektowaga
6. Notice of Claim: Brian/Nicole Quigley Vs. Town of Cheektowaga
7. Notice of Claim: Debra Sklener Vs. Town of Cheektowaga
8. Notice of Claim: Kristin Warden Vs. Town of Cheektowaga
9. Notice of Claim: Michael Zyblewski Vs. Town of Cheektowaga

VI. Comments**A. Supervisor's Comments****B. Councilmember's Comments****C. Public Comments****VII. Adjournment**

Motion by Supervisor Holtz; Seconded by Councilmember Rogowski to adjourn the meeting at 7:05 PM.

Alice Magierski, Town Clerk



Town of Cheektowaga

Work Session

~ Minutes ~

3301 Broadway
Cheektowaga, NY 14227

<http://www.town.cheektowaga.ny.us>

Alice Magierski
716-686-3400

Tuesday, October, 11, 2011

6:00 PM

Council Office

I. Call to Order

6:00 PM Meeting called to order on October 11, 2011 at Council Office, Conference Room, Cheektowaga, NY.

Attendee Name	Organization	Title	Status	Arrived
Mary Holtz	Town of Cheektowaga	Supervisor	Present	
Patricia Jaworowicz	Town of Cheektowaga	Councilmember	Absent	
Jeff Swiatek	Town of Cheektowaga	Councilmember	Absent	
James Rogowski	Town of Cheektowaga	Councilmember	Present	
Richard Zydel	Town of Cheektowaga	Councilmember	Present	
Charles Markel	Town of Cheektowaga	Councilmember	Absent	
Stanley Kaznowski	Town of Cheektowaga	Councilmember	Present	

II. Resolutions



1. RESOLUTION 2011-553

Amended Notice to Bidders - Grouting Sanitary Sewers

Sponsored By: Councilmember Kaznowski, Councilmember Zydel

WHEREAS, by resolution dated October 3, 2011 (Resolution 2011-538), a Notice to Bidders was issued for the furnishing of equipment and operators for the grouting, cleaning and televising of various sanitary sewers in the Town of Cheektowaga, and

WHEREAS, bid proposals were scheduled to be opened on October 12, 2011 at 11:00 a.m., and

WHEREAS, said Notice to Bidders was inadvertently not published in the CHEEKTOWAGA BEE; as such, the date for opening of bid proposals needs to be extended so that the Notice to Bidders can be published in the CHEEKTOWAGA BEE, NOW, THEREFORE, BE IT

RESOLVED, that sealed bids for the furnishing of equipment and operators for the grouting, cleaning and televising of various sanitary sewers in the Town of Cheektowaga will be received on the 19th day of October, 2011 at 11:00 a.m. at a public bid opening to be held in the Council Chambers at the Cheektowaga Town Hall, and BE IT FURTHER

RESOLVED, that the Town Clerk be directed to publish a Notice to Bidders for the furnishing of equipment and operators for the grouting, cleaning and televising of various sanitary sewers in the Town of Cheektowaga in the CHEEKTOWAGA BEE

NOTICE TO BIDDERS

Sealed proposals will be received and considered by the Town Board of the Town of Cheektowaga on October 19, 2011 at 11:00 am at the Town Hall, corner of Broadway and Union Roads, for the furnishing of equipment and operators for the grouting, cleaning and televising of various sanitary sewers in the Town of Cheektowaga for a one (1) year contract covering October 2011 to October 2012.

Information for bidders and specifications may be obtained from the Town Clerk at her office in said Town Hall.

Proposals shall be submitted in a sealed envelope plainly marked on the outside "Bid for Furnishing of Equipment and Operators for the Grouting, Cleaning and Televising of Various Sanitary Sewers" and submitted to the Town Clerk prior to bid opening.

No bidder may withdraw his bid within forty-five (45) days after the actual date of the opening thereof.

The Town Board reserves the right to consider informal any bid not prepared and submitted in accordance with the provisions of the specifications and contract documents, and may waive any informalities, make an award to other than the low bidder, should it be in the best interest of the Town, or reject any or all bids.

Each proposal must be accompanied by a certified check for a sum equal to five percent (5%) of the amount of the bid, payable to the Town of Cheektowaga, New York, or bond with sufficient sureties to be approved by the attorney for the Town of Cheektowaga, New York.

The successful bidder will be required to furnish a Performance Bond acceptable to the Owner in an amount equal to the contract award.

BY ORDER OF THE TOWN BOARD OF THE TOWN OF CHEEKTOWAGA, ERIE COUNTY, NEW YORK.

Alice Magierski, Town Clerk

DATED: October 11, 2011

RESULT:	ADOPTED [UNANIMOUS]
MOVER:	Stanley Kaznowski, Councilmember
SECONDER:	Richard Zydel, Councilmember
AYES:	Mary Holtz, James Rogowski, Richard Zydel, Stanley Kaznowski
ABSENT:	Patricia Jaworowicz, Jeff Swiatek, Charles Markel



2. RESOLUTION 2011-554

Authorize Supervisor to Execute Lease with Board of Elections

Sponsored By: Supervisor Holtz, Councilmember Kaznowski

WHEREAS, the Town of Cheektowaga is the owner of the following buildings:

- 222 Autumnwood Drive (Dartwood Community Center)
- 3459 Broadway (Cheektowaga Senior Citizens Center)

and

WHEREAS, the Erie County Board of Elections has requested the use of these buildings on Primary Day, September 13, 2011 and Election Day, November 8, 2011 for polling locations, and

WHEREAS, the Director of Department of Parks Department and the Director of the Senior Services Department have no objection to the use of such buildings, NOW, THEREFORE, BE IT

RESOLVED, that the Supervisor be and hereby is authorized and directed to execute lease(s) with the Board of Elections for use of the above referenced Town buildings.

RESULT:	ADOPTED [UNANIMOUS]
MOVER:	Mary Holtz, Supervisor
SECONDER:	Stanley Kaznowski, Councilmember
AYES:	Mary Holtz, James Rogowski, Richard Zydell, Stanley Kaznowski
ABSENT:	Patricia Jaworowicz, Jeff Swiatek, Charles Markel



Town of Cheektowaga

Regular Meeting

~ Minutes ~

3301 Broadway
Cheektowaga, NY 14227

<http://www.town.cheektowaga.ny.us>

Alice Magierski
716-686-3400

Monday, October, 17, 2011

6:45 PM

Council Chambers

I. Call to Order

6:45 PM Meeting called to order on October 17, 2011 at Council Chambers, 3301 Broadway St, Cheektowaga, NY.

Attendee Name	Organization	Title	Status	Arrived
Mary Holtz	Town of Cheektowaga	Supervisor	Present	
Patricia Jaworowicz	Town of Cheektowaga	Councilmember	Present	
Jeff Swiatek	Town of Cheektowaga	Councilmember	Present	
James Rogowski	Town of Cheektowaga	Councilmember	Present	
Richard Zydel	Town of Cheektowaga	Councilmember	Present	
Charles Markel	Town of Cheektowaga	Councilmember	Present	
Stanley Kaznowski	Town of Cheektowaga	Councilmember	Absent	

2. Additional Attendees

Thomas Adamczak, Supervising Building and Plumbing Inspector
Jerry Gabryszak, Director of Community Development
Captain John Glascott, Police Department
Brian Krause, Director of Finance and Administration
William Pugh, Town Engineer
Anthony Romano, Coordinator of Employee Relations
Kevin Schenk, Town Attorney

II. Public Comment Period

III. Resolutions



1. RESOLUTION 2011-555

Transfer of Funds

Sponsored By: Supervisor Holtz, Councilmember Swiatek

BE IT RESOLVED, that the following transfer is hereby approved and made a part hereof;

GENERAL FUND

FROM:	100.7140.1971.1612	Part Time Regular	\$ 1,500.00
	100.7140.1971.1630	Part Time Regular	2,000.00
	100.7140.1971.1642	Part Time Regular	2,000.00
	100.7140.1971.1615	Part Time Regular	1,000.00
	100.7140.1971.1645	Part Time Regular	2,000.00
	100.7140.1971.1815	Part Time Regular	300.00
	100.7140.1971.1815	Part Time Regular	1,500.00
	100.7310.1902	Overtime Payroll	600.00
TO:	100.7140.1971.1613	Part Time Regular	\$ 1,500.00
	100.7140.1971.1633	Part Time Regular	2,000.00
	100.7140.1971.1633	Part Time Regular	2,000.00
	100.7140.1971.1633	Part Time Regular	1,000.00
	100.7140.1971.1636	Part Time Regular	2,000.00
	100.7140.1971.1646	Part Time Regular	300.00
	100.7310.1971.1814	Part Time Regular	1,500.00
	100.7140.1902	Overtime Payroll	600.00

SPECIAL DISTRICTS FUND

FROM:	255.8125.4021	Maintenance Supplies	\$ 33.00
	400.8140.4476	Pest Control	2,841.20
TO:	255.8125.4087	Training & Conferences	\$ 33.00
	400.8140.4543	Maintenance	2,841.20

HIGHWAY FUND

FROM:	300.1910.2665	Sale of Equipment	\$ 7,600.00
TO:	300.5140.4191	Misc. Expenses	\$ 7,600.00

RESULT:	ADOPTED [UNANIMOUS]
MOVER:	Mary Holtz, Supervisor
SECONDER:	Jeff Swiatek, Councilmember
AYES:	Holtz, Jaworowicz, Swiatek, Rogowski, Zydel, Markel
ABSENT:	Stanley Kaznowski



2. RESOLUTION 2011-556

Warrant

Sponsored By: Supervisor Holtz, Councilmember Swiatek

BE IT RESOLVED, that the following Vouchers & Warrants submitted to the Town of Cheektowaga prior to October 14, 2011 are hereby approved and made a part hereof;

General Fund	\$3,029,953.96
Risk Retention Fund	105,685.40
HUD Housing Rehabilitation	13,694.00
Special Districts Fund	1,087,198.42
Highway Fund	492,066.35
Capital Fund	1,319,534.26
Trust & Agency	8,190.01
HUD CDBG Fund	3,013.80
Part Town Fund	121,968.77
NYS Affordable Housing	<u>6,568.69</u>
	\$6,187,873.66

RESULT:	ADOPTED [UNANIMOUS]
MOVER:	Mary Holtz, Supervisor
SECONDER:	Jeff Swiatek, Councilmember
AYES:	Holtz, Jaworowicz, Swiatek, Rogowski, Zydel, Markel
ABSENT:	Stanley Kaznowski



3. RESOLUTION 2011-557

Nullify Change Order No. 2 (General Construction) Police & Court Building Renovations & Addition

Sponsored By: Supervisor Holtz, Councilmember Rogowski

WHEREAS, by Town Board Resolution dated May 16, 2011 this Town Board approved Change Order No. 2 (General Construction Work) which amended the contract with Burgio & Campofelice, Inc., General Contractor for the Police & Court Building Renovations and Addition Project, providing for the addition of \$66,271.00 for work associated with the purchase, installation and coordination of furniture and fixtures in the new Dispatch Room, AND

WHEREAS, the acquisition and installation of the Dispatch furniture and equipment is a critical time sensitive aspect of this Project, and inability to timely complete this portion of the Project would seriously imperil the completion of the Project, AND

WHEREAS, the unforeseen urgent situation requires immediate action to acquire and install the Dispatch Room furniture and equipment directly through the equipment vendor, AND

WHEREAS, it has been determined that the equipment acquisition and installation can best be expedited in the most economical fashion through the Town's direct purchase from the equipment vendor, AND

WHEREAS, it is, therefore, the intention of the Town of Cheektowaga to nullify Change Order No. 2 (General Construction Work) through the approval and acceptance of Change Order No. 5 (General Construction Work) representing a credit in the amount of \$66,271.00 to the General Construction Contract with Burgio & Campofelice, Inc., NOW, THEREFORE, BE IT

RESOLVED, that Change Order No. 5 (General Construction Work) in the amount of \$66,271.00 be approved as a CREDIT to the contract for General Construction Work with Burgio & Campofelice, Inc., AND, BE IT FURTHER

RESOLVED, that the Supervisor is hereby authorized and directed to execute said Change Order document on behalf of this Town Board.

RESULT:	ADOPTED [UNANIMOUS]
MOVER:	Mary Holtz, Supervisor
SECONDER:	James Rogowski, Councilmember
AYES:	Holtz, Jaworowicz, Swiatek, Rogowski, Zydel, Markel
ABSENT:	Stanley Kaznowski



4. RESOLUTION 2011-558

Change Order No. 4 (General Construction) Police & Court Building Renovations and Addition

Sponsored By: Supervisor Holtz, Councilmember Rogowski

WHEREAS, the contract for General Construction Work for the Police & Court Building Renovations and Addition was awarded by Town Board Resolution dated September 7, 2010 to Burgio & Campofelice, Inc., 2570 Walden Avenue, Cheektowaga, New York 14225 in the amount of \$9,033,643.00, AND

WHEREAS, the project architect, Trautman Associates, and the Town Engineer have recommended the approval of Change Order No. 4 (General Construction Work) which provides for an addition and a credit to the original contract amount as further outlined in the change order documents, NOW, THEREFORE, BE IT

RESOLVED, that Change Order No. 4 (General Construction Work) for the Police & Court Building Addition and Renovations Project, as an addition to the contract for General Construction Work in the amount of \$7,463.00 to be offset by the contract contingency allowance, be and hereby is approved, AND, BE IT FURTHER

RESOLVED, that the Supervisor is hereby authorized and directed to execute said Change Order No. 4 document on behalf of this Town Board.

RESULT:	ADOPTED [UNANIMOUS]
MOVER:	Mary Holtz, Supervisor
SECONDER:	James Rogowski, Councilmember
AYES:	Holtz, Jaworowicz, Swiatek, Rogowski, Zydel, Markel
ABSENT:	Stanley Kaznowski



5. RESOLUTION 2011-559

Call for Public Hearing for Community Development Funds

Sponsored By: Councilmember Markel, Supervisor Holtz

WHEREAS, the Town of Cheektowaga is eligible to receive funding from the Department of Housing and Urban Development under the Community Development Block Grant and HOME Investment Partnerships Programs for the 2012 Program Year, and

WHEREAS, the Town of Cheektowaga is required to prepare and submit to the Department of Housing and Urban Development an Annual Plan which identifies the activities that the Town will carry-out during the next program year, and

WHEREAS, the Town is required to hold public hearings to obtain the views of Town residents, public agencies and other interested parties on housing and community development needs and to review program performance during the previous program year, NOW, THEREFORE, BE IT

RESOLVED, that a public hearing be held on November 7, 2011 at 6:45 P.M. at Cheektowaga Town Hall, 3301 Broadway at Union Road, Cheektowaga, NY 14227 for the above stated purpose, and BE IT

FURTHER RESOLVED, that a public notice of such public hearing be published in the Cheektowaga Bee.

Notice of Public Hearing
Town of Cheektowaga FY 2012 Annual Plan
Community Development Block Grant/HOME Programs

A Public Hearing will be held on Monday, November 7, 2011 at 6:45 P.M. at Cheektowaga Town Hall, 3301 Broadway, Cheektowaga, New York, regarding the Town of Cheektowaga's Year 2012 Annual Plan for the Community Development Block Grant (CDBG) and HOME Investment Partnership (HOME) Programs.

The amount of CDBG and HOME funding for which the Town will be eligible next year has not yet been determined by the Department of Housing and Urban Development (HUD). In 2010, the Town received \$ 971,310 in CDBG funds and \$335,727 in HOME funds. The purpose of the hearing is to solicit the views of citizens, public agencies and other interested parties on housing and community development needs throughout the Town and to review program performance of the Town's Community Development Program. A complete listing of eligible activities can be obtained from the Town Community Development Office at the address listed below.

Residents of low income neighborhoods and all citizens of the Town and Villages are encouraged to participate and express their views on the use of funds and activities that may be carried out with program funds. Although not likely, CDBG or HOME funded activities may result in displacement. In the event displacement due to CDBG or HOME funded activities occurs, relocation assistance will be provided in conformity with the

requirements of the Uniform Relocation Act of 1970, implementing regulations in 24 CFR Part 42, and regulations governing the CDBG program at 24 CFR 570.606.

Upon prior request, an interpreter will be made available at the hearing to sign for the hearing impaired. Please contact the Cheektowaga Community Development Office (716-897-7200) seven days prior to the hearing if you need such special arrangements. The hearing location is accessible to the physically disabled. Written comments may be submitted to the Town of Cheektowaga Office of Community Development, 275 Alexander Avenue, Cheektowaga, New York, 14211.

RESULT:	ADOPTED [UNANIMOUS]
MOVER:	Charles Markel, Councilmember
SECONDER:	Mary Holtz, Supervisor
AYES:	Holtz, Jaworowicz, Swiatek, Rogowski, Zydel, Markel
ABSENT:	Stanley Kaznowski



6. RESOLUTION 2011-560

Negative SEQR Declaration - Key Bank ATM Kiosk -3825 Union Road

Sponsored By: Councilmember Markel, Councilmember Rogowski

WHEREAS, pursuant to the Environmental Impact Review Ordinance of the Town of Cheektowaga, the Environmental Advisory Committee ("EAC") reviews various applications for site plans, rezonings, special permits, etc. and renders its recommendation concerning the environmental significance of such application, AND

WHEREAS, the Town Board, pursuant to the Environmental Impact Review Ordinance of the Town of Cheektowaga, is designated the Lead Agency in most instances, AND

WHEREAS, since the Town Board is the Lead Agency, it must affirm, modify or reject any recommendations submitted to it by the Advisory Committee, AND

WHEREAS, an application was submitted by Zaxis Architectural, P.C. on behalf of Key Bank and DDR, LLC for a special use permit to construct a drive up Automated Teller Machine (ATM) within the retail plaza parking area at 3825 Union Road, AND

WHEREAS, the Environmental Advisory Committee recommended a determination of non-significance, AND

WHEREAS, the Town of Cheektowaga Planning Board recommended approval of the site plan and special use permit at their meeting of May 12, 2011, AND

WHEREAS, the Town of Cheektowaga Traffic Safety Commission has reviewed the subject project and is recommending its approval, AND

WHEREAS, this Town Board has reviewed the application submitted and the recommendations made by the Environmental Advisory Committee, the Planning Board and the Traffic Safety Commission NOW, THEREFORE, BE IT

RESOLVED, that this Town Board determines that the project will not have a significant effect on the environment and therefore issues a Negative Declaration for purposes of SEQRA, AND BE IT

FURTHER RESOLVED, the proposed site plan is found to be acceptable

Attachments:

key bank atm kiosk site plan (PDF)

Traffic Safety Commission Recommendation (PDF)

RESULT: ADOPTED [UNANIMOUS]

MOVER: Charles Markel, Councilmember

SECONDER: James Rogowski, Councilmember
AYES: Holtz, Jaworowicz, Swiatek, Rogowski, Zydel, Markel
ABSENT: Stanley Kaznowski



7. RESOLUTION 2011-561

Approve Special Use Permit for 3825 Union Road

Sponsored By: Councilmember Markel, Supervisor Holtz

WHEREAS, Zaxis Architectural. P.C. has applied for a Special Use Permit to establish a stand alone drive through Automatic Teller Machine (ATM) on property owned by Developers Diversified Realty and located at 3825 Union Road, Cheektowaga, New York, pursuant to Sections 260-47 and 260-48.2 of the Code of the Town of Cheektowaga ("Zoning Law"); and

WHEREAS, a public hearing was held before the Cheektowaga Town Board on the 6th day of September, 2011 at 6:45 P.M. of said day for the purpose of considering said application for a Special Use Permit, after publication and service of the notices required by the provisions of the Zoning Law and the Town Law; and all interested parties were given an opportunity to be heard at such hearing; and

WHEREAS, the Cheektowaga Planning Board has recommended approval of this Special Permit; and

WHEREAS, this Town Board previously issued a Negative Declaration under SEQRA for this project; NOW, THEREFORE BE IT

RESOLVED, that the proposed drive through is consistent with the requirements of Sections 260-48.2 and 260-47 of the Zoning Law, and BE IT FURTHER

RESOLVED, that the aforesaid Special Use Permit for a stand alone drive through Automatic Teller Machine be and hereby is granted.

LEGAL DESCRIPTION FOR SPECIAL USE PERMIT

ALL THAT TRACT OR PARCEL OF LAND, situated in the Town of Cheektowaga, County of Erie and State of New York, being part of Lot No. 12, Township 11, Range 7 of the Holland Land Company's Survey described as follows:

BEGINNING at the point of intersection of the southeasterly line of lands of the West Shore Railroad Company with the easterly line of Union Road as now laid out and shown on a map recorded in the Erie County Clerk's Office in Liber 3838 of Deeds at page 56; running thence southerly along said easterly line of Union Road, 350.14 feet; thence southeasterly along a line drawn as shown on said map, 63.64 feet to the northerly line of George Urban Boulevard as actually paved and used 80 feet wide; thence easterly along the northerly line of George Urban Boulevard, 894.94 feet; thence northerly at right angles to George Urban Boulevard, 593.96 feet to the northerly line of lands conveyed to Groveland Land Corporation by deed recorded in Liber 1951 of Deeds at page 26; thence westerly along said northerly line of Groveland Land Corporation, 608.30 feet to the southeasterly line of lands of the West Shore Railroad Company; thence southwesterly along the southeasterly line of lands of the West Shore Railroad Company, 384.66 feet to the easterly line of Union Road at the point or place of beginning.

RESULT: ADOPTED [UNANIMOUS]
MOVER: Charles Markel, Councilmember
SECONDER: Mary Holtz, Supervisor
AYES: Holtz, Jaworowicz, Swiatek, Rogowski, Zydel, Markel
ABSENT: Stanley Kaznowski



8. RESOLUTION 2011-562

Authorize Town Clerk to Issue New/Renewal Ambulance Drivers/Attendants Licenses

Sponsored By: Councilmember Zydel, Councilmember Jaworowicz

WHEREAS, on the 7th day of May, 1984, this Town Board adopted an Ambulance Ordinance. The EMS Board, which was created at that time, has completed a review and evaluation of new/renewal license applications for driver(s)/attendant(s), and has recommended that the Town Board issue such licenses, NOW, THEREFORE BE IT

RESOLVED, that the recommendations of the EMS Board concerning the licensing of new/renewal driver(s)/attendant(s) shown on the list below be and hereby are accepted and approved, for a period to expire upon the expiration of such ambulance driver(s)/attendant(s) Emergency Medical Technician ('EMT') card and, BE IT FURTHER

RESOLVED, that the Town Clerk be and hereby is authorized, empowered and directed to issue new/renewal licenses to the driver(s)/attendant(s) set forth on the annexed schedule, pursuant to the terms of this resolution.

TOWN OF CHEEKTOWAGA DRIVER/ATTENDANT LICENSE LIST

<u>Name</u>	<u>Expiration Date</u>
Akromas, Nicholas P , ,	1/20/2012
Anderson, Charles P , ,	1/31/2012
Ast, Paul R , ,	6/30/2014
Baj, Michael J , ,	9/30/2014
Barberio, Ashley M , ,	1/31/2014
Barkey, Eric N , ,	2/28/2013
Bluhm, Garry F , ,	6/30/2014
Brady, Maureen R , ,	1/31/2014
Burrows, Timothy R , ,	9/30/2013
Collins, Amy L , ,	5/31/2014
Collins, Jordan E , ,	6/30/2014
Cuillo, Robert J , ,	5/31/2014
Cutter, Michael D , ,	5/31/2014
Duffett, Justin D , ,	12/31/2013

Evans, Lillian I. , ,	7/31/2014
Fox, Keri M , ,	1/31/2014
Guercio, James S , ,	7/31/2012
Hardy, Jeremy C , ,	8/31/2014
Harris, Tiffany E. , ,	4/30/2014
<u>Name</u>	<u>Expiration Date</u>
Heary, Jeremy J , ,	7/31/2014
Ignatowski, Kimberly A , ,	9/30/2014
Kruger, Wayne M , ,	7/31/2014
Kullerkupp, Peace , ,	5/31/2014
Lew, Sarah M , ,	1/31/2014
Maroney, Heather L , ,	6/30/2013
Mazurowski, Thomas E , ,	11/30/2014
McCartin, Robert W , ,	1/31/2014
Mock, Dale A , ,	6/30/2012
Moleski, Richard M , ,	5/31/2014
Monroe, David M , ,	1/31/2014
Murray, Nathan T.	01/20/12
Newton, Rebecca S , ,	9/30/2013
Noworyta, Mark F , ,	7/31/2014
Purcell, Connor J , ,	1/31/2013
Ross, Bruce L , ,	4/30/2012
Rutecki, Jason D , ,	10/31/2014
Slusser, David H Jr , ,	7/31/2014
Sullivan, Neil C , ,	5/31/2014
Then, Scott D , ,	11/30/2012
Wood, James A , ,	6/30/2014

RESULT:	ADOPTED [UNANIMOUS]
MOVER:	Richard Zydel, Councilmember
SECONDER:	Patricia Jaworowicz, Councilmember
AYES:	Holtz, Jaworowicz, Swiatek, Rogowski, Zydel, Markel
ABSENT:	Stanley Kaznowski



9. RESOLUTION 2011-563

Authorize Purchase of Furniture and Equipment for the New Dispatch Room

Sponsored By: Supervisor Holtz, Councilmember Rogowski

WHEREAS, Trautman Associates, the Town's Project Architect for the Police and Court Building Renovations and Addition Project ("Project"), and the Town Engineer have advised this Town Board of the unforeseen urgent need to expedite the purchase and installation of furniture and equipment for the Dispatch Room, AND

WHEREAS, immediate action, which cannot await competitive bidding, is required to purchase and install the Dispatch Room furniture and equipment directly from the equipment vendor; a delay in the purchase and installation of this furniture and equipment will imperil timely completion of the Project, AND

WHEREAS, Xybix Systems, Inc. has the furniture and equipment required and can supply and install same to ensure the timely completion of the Project, NOW, THEREFORE, BE IT

RESOLVED, that the contract for work associated with the furnishing and installation of furniture and fixtures and related equipment for the new Dispatch Room be awarded to Xybix Systems, Inc., 8207 South Park Circle, Littleton, Colorado 80120 for the purchase price of \$63,503.22, AND, BE IT FURTHER

RESOLVED, that said furniture purchase and installation shall be chargeable to Account #500-1440-2528-5025.

RESULT:	ADOPTED [UNANIMOUS]
MOVER:	Mary Holtz, Supervisor
SECONDER:	James Rogowski, Councilmember
AYES:	Holtz, Jaworowicz, Swiatek, Rogowski, Zydel, Markel
ABSENT:	Stanley Kaznowski



10. RESOLUTION 2011-564

Acceptance of Buffer Zone Protection Program Grant

Sponsored By: Councilmember Zydel, Councilmember Markel

WHEREAS, grant monies were available through the Buffer Zone Protection Program via the U.S. Department of Homeland Security, administered through the New York State Division of Homeland Security and Emergency Services, Office of Counter Terrorism, and

WHEREAS, the Town submitted a grant application as lead agency, in conjunction with Walden District Fire Company #2, for funding through the FY2009 call for applications, and

WHEREAS, the Town recently received notification of award for a FY 2009 Buffer Zone Protection Program grant in the amount of \$97,582.405, NOW, THEREFORE, BE IT

RESOLVED, that Grantmakers Advantage, Inc. the Town's grants consultant, be and hereby is authorized and directed to complete the necessary forms and reports for the purpose of maintaining this grant, and BE IT FURTHER

RESOLVED, that the grant acceptance is subject to the Town entering into a Memorandum of Understanding with Walden District Fire Company #2 regarding this project, subject to approval by the Town Attorney, and BE IT FURTHER

RESOLVED, that the Supervisor is hereby authorized and directed to execute any and all documents pertaining to the application for and acquisition of said funding.

RESULT:	ADOPTED [UNANIMOUS]
MOVER:	Richard Zydel, Councilmember
SECONDER:	Charles Markel, Councilmember
AYES:	Holtz, Jaworowicz, Swiatek, Rogowski, Zydel, Markel
ABSENT:	Stanley Kaznowski



11. RESOLUTION 2011-565

Unsafe-Unsecured / 376 Pine Ridge Road

Sponsored By: Councilmember Markel, Councilmember Zydel

WHEREAS, Town of Cheektowaga Law for the Administration and Enforcement of the Codes of New York State; and the Property Maintenance Code of New York State require that all vacant structures and premises shall be maintained in clean, safe, secure and sanitary conditions so as not to cause a blighting problem or adversely affect the public health or safety and all nuisances abated, AND

WHEREAS, the Town of Cheektowaga has received notification of an unsafe structure and premises located at 376 Pine Ridge Road, Cheektowaga, New York SBL# 101.28-7-12 that is a danger to the safety of others, and records kept by the Assessors Office identify David Swain & Jerry Swain, 376 Pine Ridge Road, Cheektowaga, New York 14225, as the owner AND

WHEREAS, an inspection of such premises was conducted at 376 Pine Ridge Road, by the Housing and Neighborhood Preservation Office, AND

WHEREAS, such inspection found the premises to be deteriorated, vacant, a hazard, and a danger to the safety and well being of others, AND

WHEREAS, the Town of Cheektowaga Housing and Neighborhood Preservation Office properly notified the property owner in accordance with the Town of Cheektowaga Law for the Administration and Enforcement of the Codes of New York State, and the owner failed to take actions to safeguard the premises, AND

WHEREAS, these conditions require the Town of Cheektowaga Housing and Neighborhood Preservation Office to take immediate steps to safeguard the premises to protect the health and safety of others and abate all nuisances, NOW, THEREFORE BE IT

RESOLVED, that pursuant to Section 70-7A.(5) and Section 70-8 of the Town of Cheektowaga Law for the Administration and Enforcement of the Codes of New York State that the vacant structure premises be safeguarded and all nuisances abated; and all costs incurred be assessed against the property hereinbefore described.

RESULT:	ADOPTED [UNANIMOUS]
MOVER:	Charles Markel, Councilmember
SECONDER:	Richard Zydel, Councilmember
AYES:	Holtz, Jaworowicz, Swiatek, Rogowski, Zydel, Markel
ABSENT:	Stanley Kaznowski



12. RESOLUTION 2011-566

Public Improvement Permit - 40 Leo Place (Uncle Bob's Self Storage)

Sponsored By: Councilmember Zydel, Supervisor Holtz

WHEREAS, the Public Improvement Permit Ordinance of the Town of Cheektowaga requires that all public improvements which are to be dedicated to and be maintained by the Town, be installed under a Public Improvement Permit, AND

WHEREAS, Sovran Acquisition L.P., dba Uncle Bob's Self Storage, in conjunction with the construction of a climate controlled storage building and related site drainage improvements has submitted plans and specifications and a Public Improvement Permit Application and permit fee for the replacement of 350 lineal feet of Town owned storm sewer and two (2) catch basins on the west side of Louis Street, AND

WHEREAS, the Town Engineer has reviewed the plans and specifications for the subject improvements and finds said design acceptable, NOW, THEREFORE, BE IT

RESOLVED, that the Public Improvement Permit be and hereby is approved for the proposed storm sewer improvements and modifications, AND, BE IT FURTHER

RESOLVED, that the permit fee in the amount of \$400.00 be deposited in the Public Improvement Permit Account which has been established for receipt and disbursement of such fees.

RESULT:	ADOPTED [UNANIMOUS]
MOVER:	Richard Zydel, Councilmember
SECONDER:	Mary Holtz, Supervisor
AYES:	Holtz, Jaworowicz, Swiatek, Rogowski, Zydel, Markel
ABSENT:	Stanley Kaznowski



13. RESOLUTION 2011-567

Special Event Halloween Parade Southline Fire Co.

Sponsored By: Councilmember Rogowski, Councilmember Zydel

WHEREAS, South Line Volunteer Fire Company has made application to hold their Annual Halloween Parade on Saturday, October 29, 2011 at 7:00 p.m., beginning from their firehall to Violet Senior Housing, around the building, and then returning to firehall; and

WHEREAS, this Board has reviewed the aforementioned application, which application has been approved by the Department of Parks, Recreation & Youth Services and the Police Department, and has no objection to same, and

WHEREAS, due to the nature of the event, this Town Board hereby waives the following requirements:

1. Submittal of plan for sanitary facilities;
2. Submittal of site plan;
3. Submittal of Security Plan;
4. Submittal of Fire Prevention/Emergency Services Plan;

NOW, THEREFORE, BE IT

RESOLVED, that this Town Board hereby approves the aforementioned application of the South Line Volunteer Fire Company for the aforementioned Halloween Parade to be held on Saturday, October 29, 2011 at 7:00 P.M., and BE IT FURTHER

RESOLVED, that the Chief of Police be and hereby is directed to provide traffic safety and escort services for such parade and to ensure compliance with Section 1660(a)(6) of the Vehicle and Traffic Law.

1. Submittal of Security Plan;
2. Submittal of Fire Prevention/Emergency Services Plan;

NOW, THEREFORE, BE IT

RESOLVED, that this Town Board hereby approves the aforementioned application of the South Line Volunteer Fire Company for the aforementioned Halloween Parade to be held on Saturday, October 29, 2011 at 7:00 P.M., and BE IT FURTHER

RESOLVED, that the Chief of Police be and hereby is directed to provide traffic safety and escort services for such parade and to ensure compliance with Section 1660(a)(6) of the Vehicle and Traffic Law.

RESULT:	ADOPTED [UNANIMOUS]
MOVER:	James Rogowski, Councilmember
SECONDER:	Richard Zydel, Councilmember
AYES:	Holtz, Jaworowicz, Swiatek, Rogowski, Zydel, Markel
ABSENT:	Stanley Kaznowski



14. RESOLUTION 2011-568

Hiring of Part-Time Employees

Sponsored By: Councilmember Swiatek, Supervisor Holtz

BE IT RESOLVED, that the following individuals be and hereby are hired as **PART-TIME EMPLOYEES** in the department listed, not to exceed nineteen (19) hours on a weekly basis, in compliance with Civil Service Laws and Regulations as well as the provisions of the Town's collective bargaining agreement between the Town of Cheektowaga and the Town of Cheektowaga Employees Association:

SENIOR SERVICES Van Driver (Substitute) \$8.75/hour effective 10/17/11
Leonard T. Nowak, Cheektowaga, New York
William D. Thompson, Depew, New York

Motion by Councilmember Rogowski; Seconded by Supervisor Holtz to waive the reading of names for this resolution. Motion Carried.

RESULT: ADOPTED [UNANIMOUS]
MOVER: Jeff Swiatek, Councilmember
SECONDER: Mary Holtz, Supervisor
AYES: Holtz, Jaworowicz, Swiatek, Rogowski, Zydel, Markel
ABSENT: Stanley Kaznowski



15. RESOLUTION 2011-569

Travel Authorization Police Department/Police Officers Jeffrey Schmidt, John Skonecki and Troy Blackchief

Sponsored By: Councilmember Jaworowicz, Councilmember Swiatek

WHEREAS, the New York Tactical Operators Association Team Leader Class is being held October 11 through October 13, 2011 at the Erie County Fire Training Tower; AND

WHEREAS, Police Officers Jeffrey Schmidt, John Skonecki and Troy Blackchief have requested authorization to attend said conference; AND

WHEREAS, Police Chief David Zack has submitted a request for travel authorization along with the proper paperwork in a timely manner; AND

WHEREAS, the total cost to the Town shall not exceed \$747; AND

WHEREAS, these expenses have been budgeted by the Police Department; NOW, THEREFORE, BE IT

RESOLVED, that Police Officers Jeffrey Schmidt, John Skonecki and Troy Blackchief be and hereby are authorized to attend the New York Tactical Operators Association Team Leader Class being held October 11 through October 13, 2011 at the Erie County Fire Training Tower.

RESULT:	ADOPTED [UNANIMOUS]
MOVER:	Patricia Jaworowicz, Councilmember
SECONDER:	Jeff Swiatek, Councilmember
AYES:	Holtz, Jaworowicz, Swiatek, Rogowski, Zydel, Markel
ABSENT:	Stanley Kaznowski



16. RESOLUTION 2011-570

Travel Authorization Building Inspection Department/Community Development and Engineering Department

Sponsored By: Councilmember Swiatek, Supervisor Holtz

WHEREAS, the Niagara Frontier Building Officials Association Annual Conference, is being held January 23 through January 25, 2012 at the Millennium Hotel in Cheektowaga, New York; AND

WHEREAS, the following employees have requested authorization to attend said conference in their respective departments:

Building Inspection Department

Supervising Code Enforcement Officer Thomas Adamczak

Assistant Code Enforcement Officer Lawrence Kensy

Code Enforcement Officer Gary Parks

Fire Inspector Gerald Sprada

Assistant Code Enforcement Officer Mark Radecki

Housing Inspector Donald Wartinger

Assistant Code Enforcement Officer Mark Bielefeld

Assistant Plumbing Inspector Donald O'Neill

Housing Inspector Richard Coburn

Housing Inspector (Park Time) Gerald Gill

Housing Inspector (Part Time) Lawrence Rokitka

Assistant Plumbing Inspector Gregory Magnuszewski

Assistant Code Enforcement Officer Donald Bielefeld

Assistant Code Enforcement Officer Daniel Lolito

Assistant Code Enforcement Officer (Temporary) Peter Maurer

Community Development

Assistant Code Enforcement Officer Dale Parks

Assistant Code Enforcement Officer Richard Willis

Engineering Department

Senior Engineering Assistant Gail Milburth; AND

WHEREAS, Supervising Code Enforcement Officer Thomas Adamczak has submitted a request for travel authorization along with the proper paperwork in a timely manner; AND

WHEREAS, the total cost to the Town shall not exceed \$6,778; AND

WHEREAS, these expenses have been budgeted by the Building Inspection, Community Development and Engineering Departments; NOW, THEREFORE, BE IT

RESOLVED, that the aforementioned employees be and hereby are authorized to attend the Niagara Frontier Building Officials Association Annual Conference being held January 23 through January 25, 2012 at the Millennium Hotel in Cheektowaga, New York.

RESULT: ADOPTED [UNANIMOUS]

MOVER: Jeff Swiatek, Councilmember
SECONDER: Mary Holtz, Supervisor
AYES: Holtz, Jaworowicz, Swiatek, Rogowski, Zydel, Markel
ABSENT: Stanley Kaznowski

IV. Suspension of Rules

Motion by Councilmember Markel; Seconded by Supervisor Holtz to waive the Rules to Include the following resolution. Motion Carried.



1. RESOLUTION 2011-571

Open Burning Permit for Dale Rd. St Mary's Cemetery

Sponsored By: Councilmember Markel, Councilmember Zydel

WHEREAS, pursuant to the Open Burning Law of the Town of Cheektowaga, the Fire Inspector reviews various applications for open fires and open burning and renders his recommendation concerning the fire safety and impact to the general public of such application, AND

WHEREAS, the Town Board, pursuant to the Open Burning Law of the Town of Cheektowaga, is designated the Approval Agency, AND

WHEREAS, since the Town Board is the Approval Agency, it must affirm, modify or reject any recommendations or permits submitted to it by the Town Fire Inspector, AND

WHEREAS, an application for a permit was submitted by the Walden Fire District (Rescue Fire Company) to conduct an open fire on October 29 & 30, 2011, rain date of November 5 & 6, 2011 at the property located on Dale Road, Saint Mary's Cemetery, Holy Mother of the Rosary, (Former custodians home) Cheektowaga, New York AND

WHEREAS, the applicant intends to burn small fires within this structure for training purposes. The owner of the property, St. Mary's Cemetery, Holy Mother of the Rosary has provided a letter of permission and has obtained a building permit to remove the structure following the training evolutions., AND

WHEREAS, the Fire Inspector has received this application and finds the application to be in compliance with conditions and requirements of the Town of Cheektowaga Fire Prevention Code and the Open Burning Law requests the Town Board approve issuance of a permit, AND

WHEREAS, this Town Board has reviewed the application submitted by the Walden Fire District (Rescue Fire Company) and the recommendations of the Fire Inspector, NOW, THEREFORE, BE IT

RESOLVED, that this Town Board, authorizes the Fire Inspector to issue such permit.

RESULT:	ADOPTED [UNANIMOUS]
MOVER:	Charles Markel, Councilmember
SECONDER:	Richard Zydel, Councilmember
AYES:	Holtz, Jaworowicz, Swiatek, Rogowski, Zydel, Markel
ABSENT:	Stanley Kaznowski

V. Communications

A. Departmental Communications

1. Supervisor's Statement of Funds - August 2011
2. Town of Cheektowaga Emergency Services - Quarterly Report for July to September 2011
3. Minutes: Town Environmental Advisory Committee - October 5, 2011

B. General Communications

1. Notice of Claim: Gloria Kilianski Vs. Town of Cheektowaga
2. Notice of Claim: Verizon Vs. Town of Cheektowaga

VI. Comments

A. Supervisor's Comments

B. Councilmember's Comments

C. Public Comments

VII. Adjournment

Motion by Supervisor Holtz; Seconded by Councilmember Zydel to adjourn the meeting at 7:02 PM

Alice Magierski, Town Clerk

TOWN OF CHEEKTOWAGA TRAFFIC SAFETY COMMISSION

PROJECT DESCRIPTION ATM KIOSK
 PROJECT LOCATION 4245 Union Tops
 PROJECT SPONSOR Key Bank
 INVESTIGATED BY PRZEPIORA
 DATE 14 July 11

COMMENTS Project was discussed at June Traffic Safety meeting with presentation. Several concerns were pointed out and a new plan was developed. Although the new plan keeps the original location design modifications make the new plan acceptable. The new plan allows for easier access and better control.

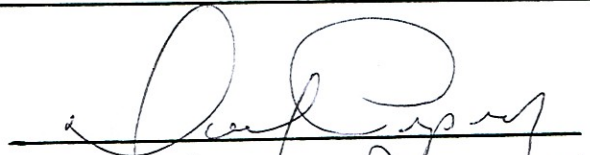
 DAVID PRZEPIORA

TOWN OF CHEEKTOWAGA

RECEIVED
 AUG 01 2011
 BUILDING & PLUMBING DEPARTMENT



Town of Cheektowaga

Special Meeting

~ Minutes ~

3301 Broadway
Cheektowaga, NY 14227
<http://www.town.cheektowaga.ny.us>

Alice Magierski
716-686-3400

Tuesday, October, 18, 2011

6:00 PM

Council Chambers

I. Call to Order

6:00 PM Meeting called to order on October 18, 2011 at Council Chambers, 3301 Broadway St, Cheektowaga, NY.

Attendee Name	Organization	Title	Status	Arrived
Mary Holtz	Town of Cheektowaga	Supervisor	Present	
Patricia Jaworowicz	Town of Cheektowaga	Councilmember	Absent	
Jeff Swiatek	Town of Cheektowaga	Councilmember	Present	
James Rogowski	Town of Cheektowaga	Councilmember	Present	
Richard Zydel	Town of Cheektowaga	Councilmember	Present	
Charles Markel	Town of Cheektowaga	Councilmember	Present	
Stanley Kaznowski	Town of Cheektowaga	Councilmember	Absent	

2. Additional Attendees

Thomas Adamczak, Supervising Building and Plumbing Inspector
Ellen Fischer, Executive Director - Youth Board
Brian Krause, Director of Finance and Administration
Jon Nichey, Superintendent of Wastewater Pump Station
William Pugh, Town Engineer
Anthony Romano, Coordinator of Employee Relations
Kevin Schenk, Town Attorney
Kerry Switalski, Senior Services Director

II. Public Portion

III. Public Hearings

1. 2012 Preliminary Ad Valorem Budget

This being the time and place advertised for a Public Hearing, the Supervisor directed the Town Clerk to present that such notice has been duly published and posted; upon the order of the Supervisor such proof was duly filed.

The Supervisor announced that the Town Board would hear all persons interested in the subject of the hearing. Comments were heard, after which the Supervisor declared the hearing closed, decision was reserved.

RESULT: CLOSED [UNANIMOUS]
MOVER: Mary Holtz, Supervisor
SECONDER: Jeff Swiatek, Councilmember

AYES: Holtz, Swiatek, Rogowski, Zydel, Markel
ABSENT: Patricia Jaworowicz, Stanley Kaznowski

2. Benefit Basis Budget

This being the time and place advertised for a Public Hearing, the Supervisor directed the Town Clerk to present that such notice has been duly published and posted; upon the order of the Supervisor such proof was duly filed.

The Supervisor announced that the Town Board would hear all persons interested in the subject of the hearing. Comments were heard, after which the Supervisor declared the hearing closed, decision was reserved.

RESULT: CLOSED [UNANIMOUS]
MOVER: Mary Holtz, Supervisor
SECONDER: Jeff Swiatek, Councilmember
AYES: Holtz, Swiatek, Rogowski, Zydel, Markel
ABSENT: Patricia Jaworowicz, Stanley Kaznowski

IV. Adjournment

Motion by Supervisor Holtz; Seconded by Councilmember Swiatek to adjourn the meeting.
Meeting closed at 6:18 PM

Alice Magierski, Town Clerk



Town of Cheektowaga

Work Session

~ Minutes ~

3301 Broadway
Cheektowaga, NY 14227

<http://www.town.cheektowaga.ny.us>

Alice Magierski
716-686-3400

Tuesday, November, 1, 2011

6:00 PM

Council Office

I. Call to Order

6:00 PM Meeting called to order on November 1, 2011 at Council Office, Conference Room, Cheektowaga, NY.

Attendee Name	Organization	Title	Status	Arrived
Mary Holtz	Town of Cheektowaga	Supervisor	Present	
Patricia Jaworowicz	Town of Cheektowaga	Councilmember	Absent	
Jeff Swiatek	Town of Cheektowaga	Councilmember	Present	
James Rogowski	Town of Cheektowaga	Councilmember	Present	
Richard Zydel	Town of Cheektowaga	Councilmember	Present	
Charles Markel	Town of Cheektowaga	Councilmember	Present	
Stanley Kaznowski	Town of Cheektowaga	Councilmember	Present	

II. Resolutions



1. RESOLUTION 2011-572

Award of Bid - Grouting & Cleaning of Sanitary Sewers

Sponsored By: Councilmember Kaznowski, Councilmember Zydel

WHEREAS, as a result of advertisement, bids were received on October 19, 2011 for the furnishing of equipment & operators for the grouting, cleaning and televising of various sanitary sewers in the Town of Cheektowaga, AND

WHEREAS, said bids were referred to the Town Engineer for analysis, tabulation and report, NOW, THEREFORE, BE IT

RESOLVED, that the contract for the furnishing of equipment & operators for the grouting, cleaning and televising of various sanitary sewers be awarded to:

Sewer Specialty Services Company, Inc.
2462 New Road
Leicester, New York 14481

for submission of the lowest bid meeting the requirements of the specifications in the amount of \$2,700/day for equipment & operators and \$10.00/gallon for grouting agent, AND, BE IT FURTHER

RESOLVED, that funds have been budgeted in Account No. 255-8125-4543 for this work.

RESULT:	ADOPTED [UNANIMOUS]
MOVER:	Stanley Kaznowski, Councilmember
SECONDER:	Richard Zydel, Councilmember
AYES:	Holtz, Swiatek, Rogowski, Zydel, Markel, Kaznowski
ABSENT:	Patricia Jaworowicz

III. Close and Enter In to Executive Session.

Motion by Supervisor Holtz; Seconded by Councilmember Rogowski. Motion Carried



Town of Cheektowaga

Regular Meeting

~ Minutes ~

3301 Broadway
Cheektowaga, NY 14227
<http://www.town.cheektowaga.ny.us>

Alice Magierski
716-686-3400

Monday, November, 7, 2011

6:45 PM

Council Chambers

I. Call to Order

6:45 PM Meeting called to order on November 7, 2011 at Council Chambers, 3301 Broadway St, Cheektowaga, NY.

Attendee Name	Organization	Title	Status	Arrived
Mary Holtz	Town of Cheektowaga	Supervisor	Present	
Patricia Jaworowicz	Town of Cheektowaga	Councilmember	Present	
Jeff Swiatek	Town of Cheektowaga	Councilmember	Present	
James Rogowski	Town of Cheektowaga	Councilmember	Present	
Richard Zydel	Town of Cheektowaga	Councilmember	Present	
Charles Markel	Town of Cheektowaga	Councilmember	Present	
Stanley Kaznowski	Town of Cheektowaga	Councilmember	Present	

II. Public Comment Period

III. Public Hearings

1. Community Development Block Grant Funds

This being the time and place advertised for a Public Hearing, the Supervisor directed the Town Clerk to present that such notice has been duly published and posted; upon the order of the Supervisor such proof was duly filed.

The Supervisor announced that the Town Board would hear all persons interested in the subject of the hearing. Comments were heard, after which the Supervisor declared the hearing closed, decision was reserved.

RESULT: CLOSED [UNANIMOUS]
MOVER: James Rogowski, Councilmember
SECONDER: Jeff Swiatek, Councilmember
AYES: Holtz, Jaworowicz, Swiatek, Rogowski, Zydel, Markel, Kaznowski

IV. Resolutions



1. RESOLUTION 2011-573

Transfer of Funds

Sponsored By: Supervisor Holtz, Councilmember Swiatek

BE IT RESOLVED, that the following transfer is hereby approved and made a part hereof;

GENERAL FUND

FROM:	100.7140.4464	Pre-K Expense	\$ 2,000.00
	100.7140.4519	After School Programs	2,000.00
	100.7140.4601	Aid to Youth	1,750.00
	100.7310.2501	Equipment	8,000.00
	100.7310.4689	Youth Conservation Corps	3,500.00
	100.1410.4188	Equipment Rental	1,000.00
TO:	100.1640.2509	Vans	\$ 17,250.00
	100.1410.4431	Equipment Maintenance	1,000.00

HIGHWAY FUND

FROM:	300.1910.2665	Sale of Equipment	\$ 3,039.30
TO:	300.5130.4462	Parts & Supplies	\$ 3,039.30

SPECIAL DISTRICTS FUND

FROM:	990.1910.2681	Light Standard Damages	\$ 1,060.00
	400.8140.4476	Ditch & Creek Pest Control	2,841.20
TO:	990.5182.4432	Repairs & Maintenance	\$ 1,060.00
	400.8140.4543	Ditch & Creek Maintenance	2,841.20

RESULT:	ADOPTED [UNANIMOUS]
MOVER:	Mary Holtz, Supervisor
SECONDER:	Jeff Swiatek, Councilmember
AYES:	Holtz, Jaworowicz, Swiatek, Rogowski, Zydel, Markel, Kaznowski



2. RESOLUTION 2011-574

Warrant

Sponsored By: Supervisor Holtz, Councilmember Swiatek

BE IT RESOLVED, that the following Vouchers & Warrants submitted to the Town of Cheektowaga prior to November 4, 2011 are hereby approved and made a part hereof;

GENERAL FUND	\$ 2,830,271.08
RISK RETENTION FUND	95,074.92
HUD HOUSING REHABILITATION FUND	39,027.00
SPECIAL DISTRICTS FUND	842,907.36
HIGHWAY FUND	648,824.41
CAPITAL FUND	1,870,628.07
TRUST & AGENCY FUND	51,454.19
HUD CDBG FUND	3,064.81
PART TOWN FUND	148,617.19
NYS AFFORDABLE HOUSING	47,139.00
	<u>\$ 6,577,008.03</u>

RESULT: **ADOPTED [UNANIMOUS]**

MOVER: Mary Holtz, Supervisor

SECONDER: Jeff Swiatek, Councilmember

AYES: Holtz, Jaworowicz, Swiatek, Rogowski, Zydel, Markel, Kaznowski



3. RESOLUTION 2011-575

Adopt Benefit Basis Budget for 2012

Sponsored By: Holtz, Jaworowicz, Swiatek, Rogowski, Markel, Zydel, Kaznowski

WHEREAS, Mary F. Holtz, Supervisor of the Town of Cheektowaga, New York, presented a Budget and Assessment Roll showing the various sums of money that were and will be required to defray the expenses of the Special Districts respectively and does determine same to be necessary and required as set forth, namely:

Town of Cheektowaga Final Benefit Basis Budget, AND

WHEREAS, a Public Hearing was duly held on the 18th day of October, 2011 at 6:00 P.M. in relation to the Preliminary Benefit Basis Budget, as provided by law, with amendments made to same, NOW, THEREFORE, BE IT

RESOLVED, that the Budget and Assessment Roll for Special Districts in the Town of Cheektowaga, be and the same is hereby adopted, AND, BE IT FURTHER

RESOLVED, that the Supervisor be and hereby is directed to cause same to be spread on the Tax Roll for the Year 2012.

RESULT:	ADOPTED [UNANIMOUS]
MOVER:	Mary Holtz, Supervisor
SECONDER:	Patricia Jaworowicz, Councilmember
AYES:	Holtz, Jaworowicz, Swiatek, Rogowski, Zydel, Markel, Kaznowski



4. RESOLUTION 2011-576

Adopt Ad Valorem Budget for 2012

Sponsored By: Holtz, Jaworowicz, Rogowski, Zydel, Markel, Kaznowski, Swiatek

WHEREAS, officers and employees in charge of the various administrative units of the government of the Town of Cheektowaga have submitted estimate of revenues and expenditures for the 2012 fiscal year, AND

WHEREAS, the Supervisor, as the Town's Budget Officer, has caused a tentative budget to be prepared, and the Town Clerk has presented such budget to this Town Board, AND

WHEREAS, this Town Board has met and considered the preliminary budget for the fiscal year beginning January 1, 2012, and a public hearing was conducted there on October 18, 2011 as required by Section 108 of the Town Law, NOW, THEREFORE, BE IT

RESOLVED, that the preliminary budget as changed, altered and revised and as hereinafter set forth, is hereby adopted as the annual budget of the Town of Cheektowaga for the fiscal year beginning on January 1, 2012.

RESULT:	ADOPTED [UNANIMOUS]
MOVER:	Mary Holtz, Supervisor
SECONDER:	Patricia Jaworowicz, Councilmember
AYES:	Holtz, Jaworowicz, Swiatek, Rogowski, Zydel, Markel, Kaznowski



5. RESOLUTION 2011-577

Amend Award of Bid for Asbestos Surveys

Sponsored By: Councilmember Markel, Councilmember Kaznowski

WHEREAS, by resolution dated October 3, 2011 (Resolution 2011-533) this Town Board awarded a bid for asbestos surveys, specifications and air monitoring services for the following properties located in the Town of Cheektowaga: 3048 William Street, 74 Hoerner Avenue, 15 Atwood Place, 44A Windwood Court, and 29E Glenwood Court, all of which have been deemed unsafe and recommended for demolition and removal;

WHEREAS, based on proposals submitted, Buffalo Environmental Consultants, Inc., d/b/a AFI Environmental, was the lowest responsible bidder and was retained to perform said surveys; and

WHEREAS, the cost of air monitoring services during asbestos removal (if required) and air sampling were incorrectly stated in said resolution; the bid proposal provided for said costs to be as follows:

Project/Air Sampler	\$395/day/building
PCM Samples	\$13/sample/building

NOW, THEREFORE, BE IT

RESOLVED, that the first "RESOLVED" paragraph of the aforementioned resolution be and hereby is amended to read as follows:

"RESOLVED, that this Town Board hereby retains Buffalo Environmental Consultants, Inc. d/b/a AFI Environmental, P.O. Box 4049, Niagara Falls, New York, 14304, to perform the necessary asbestos surveys, specifications and air monitoring services and sampling (if necessary) for 3048 William Street, 74 Hoerner Avenue, 15 Atwood Place, 44A Windwood Court, and 29E Glenwood Court at a total cost not to exceed the sum of \$25,660.00 (assuming 5 days of air monitoring and 59 air samples) without further Town Board approval."

RESULT:	ADOPTED [UNANIMOUS]
MOVER:	Charles Markel, Councilmember
SECONDER:	Stanley Kaznowski, Councilmember
AYES:	Holtz, Jaworowicz, Swiatek, Rogowski, Zydel, Markel, Kaznowski



6. RESOLUTION 2011-578

Award of Bid - Sidewalks

Sponsored By: Councilmember Swiatek, Supervisor Holtz

WHEREAS, the contract for the replacement of sidewalks at various locations within the Town of Cheektowaga was awarded on December 20, 2010, AND

WHEREAS, the contract allows for an annual renewal and cost adjustment based on the Consumer Price Index (CPI) as of December 31, 2011, AND

WHEREAS, the contractor has submitted the required documentation which has been reviewed and approved, NOW, THEREFORE, BE IT

RESOLVED, that the contract for the replacement of sidewalks at various locations within the Town of Cheektowaga for the period of January 1, 2012 to December 31, 2012 be extended for Valeri Concrete Construction, Inc., 6297 Wendt Drive, Niagara Falls, New York 14304 for the unit prices of:

Item 1	Replacement of Concrete Sidewalk 4" 6" with 6 X 6 X #10 reinforcing mesh	\$5.18 \$0.10
Item 2	Installation of Concrete Sidewalk 4" 6" with 6 X 6 X #10 reinforcing mesh	\$4.66 \$0.10
Item 3	Replacement of Concrete Driveway Apron	\$6.22
Item 4	Install ADA Handicap Ramps	\$362.60
Item 5	Restoration	\$0.01
Item 6	Installation of Underdrain 4" PVC 6" PVC	\$0.10 \$0.10

RESULT:	ADOPTED [UNANIMOUS]
MOVER:	Jeff Swiatek, Councilmember
SECONDER:	Mary Holtz, Supervisor
AYES:	Holtz, Jaworowicz, Swiatek, Rogowski, Zydel, Markel, Kaznowski



7. RESOLUTION 2011-579

Award of Bid - Emergency Snow Removal

Sponsored By: Councilmember Swiatek, Supervisor Holtz

WHEREAS, as a result of advertisement, bids were received and publicly opened on October 19, 2011 for emergency snow removal in the Town of Cheektowaga, NOW, THEREFORE, BE IT

RESOLVED, that the contract for emergency snow removal in the Town of Cheektowaga for the 2011-2012 winter season be awarded to Nichols, Long & Moore Construction Corporation, 149 Gunville Road, Lancaster, New York 14086 for submission of the lowest bid meeting the specifications as per the unit prices of:

		<u>Base Hourly Rate</u>
Item 1	Tandem Dump Truck	\$115.00
Item 2	Hydraulic Backhoe	125.00
Item 3	Front End Loader, 3 C.Y.	180.00
Item 4	Front End Loader, 4 C.Y.	195.00
Item 5	Front End Loader, 5 C.Y.	225.00
Item 6	Dozer, Crawler D-3	100.00
Item 7	Dozer, Crawler D-6	155.00
Item 8	Hydraulic Backhoe Crawler, 7/8 yard	117.00
Item 9	Hydraulic Backhoe Crawler, 2-1/3 yard	130.00
Item 10	Skid Steer Loader with Operator	125.00

AND, BE IT FURTHER

RESOLVED, that the line item to be used is emergency account #300-5142-4029.

RESULT:	ADOPTED [UNANIMOUS]
MOVER:	Jeff Swiatek, Councilmember
SECONDER:	Mary Holtz, Supervisor
AYES:	Holtz, Jaworowicz, Swiatek, Rogowski, Zydel, Markel, Kaznowski



8. RESOLUTION 2011-580

Notice to Bidders - Two (2) New and Unused 2012 Model or Newer, Tandem Drive Axle Cab and Chassis Heavy Duty Dump/Plow Trucks

Sponsored By: Councilmember Swiatek, Supervisor Holtz

NOTICE IS HEREBY GIVEN, that the Town of Cheektowaga Highway Department will receive bids for the purchase of TWO (2) New and Unused 2012 Model or Newer, Tandem Drive Axle Cab and Chassis Heavy Duty/Dump Trucks for use by the Highway Department in the Town of Cheektowaga at a public bid opening to be held in the Council Chambers at the Cheektowaga Town Hall on November 23, 2011 at 11:00 A.M.

Information for bidders specifications may be obtained from the office of the Town Clerk, Cheektowaga Town Hall, Broadway and Union Roads, Cheektowaga, New York, between the hour of 9:00 AM and 4:30 PM, Monday through Friday, NOW THEREFORE BE IT

RESOLVED, that the Town Clerk is hereby designated as the Officer to open bids on the aforesaid items at a public bid opening on Wednesday, November 23, 2011, at 11:00 AM, in the Council Chambers of the Cheektowaga Town Hall.

TOWN OF CHEEKTOWAGA HIGHWAY DEPARTMENT LEGAL NOTICE TO BIDDERS

NOTICE IS HEREBY GIVEN, that the Town of Cheektowaga Highway Department will receive bids for the purchase of Two (2) New and Unused 2012 Model or Newer, Tandem Drive Axle Cab and Chassis Heavy Duty Dump/Plow Trucks for use by the Highway Department in the Town of Cheektowaga at a public bid opening to be held in the Council Chambers at the Cheektowaga Town Hall on November 23, 2011 at 11:00 A.M.

Information for bidders and specifications may be obtained from the office of Alice Magierski, Town Clerk at her office located at Town Hall, Cheektowaga NY. Bids must be enclosed in an opaque envelope plainly marked "BID FOR TWO (2) NEW AND UNUSED 2012 MODEL OR NEWER, TANDEM DRIVE AXLE CAB AND CHASSIS HEAVY DUTY DUMP/PLOW TRUCKS." Non-Collusion forms must be signed and submitted with each bid. The Superintendent of Highways may reject any or all bids submitted.

Alice Magierski, TOWN CLERK

DATE: November 7, 2011
PUBLISHED: November 10, 2011

RESULT:	ADOPTED [UNANIMOUS]
MOVER:	Jeff Swiatek, Councilmember
SECONDER:	Mary Holtz, Supervisor

AYES: Holtz, Jaworowicz, Swiatek, Rogowski, Zydel, Markel, Kaznowski



9. RESOLUTION 2011-581

Notice to Bidders - Firing Range

Sponsored By: Supervisor Holtz, Councilmember Rogowski

WHEREAS, it is in order that bids be advertised for the furnishing and delivery of a Modular Bullet Trap/Containment System and Fixed Air Turning Target System Firing Range, NOW, THEREFORE, BE IT

RESOLVED, that the Town Clerk be directed to publish a Notice to Bidders for the furnishing and delivery of a Modular Bullet Trap/Containment System and Fixed Air Turning Target System Firing Range, said notice to be published in THE CHEEKTOWAGA BEE, AND, BE IT FURTHER

RESOLVED, that sealed bids will be received on the 23rd day of November, 2011 at 11:00 am, at a public bid opening to be held in the Council Chambers at the Cheektowaga Town Hall.

NOTICE TO BIDDERS

Sealed proposals will be received and considered by the Town Board of the Town of Cheektowaga on November 23, 2011 at 11:00 am, at the Town Hall, corner of Broadway and Union Roads, Cheektowaga, New York, for the furnishing and delivery of a Modular Bullet Trap/Containment System and Fixed Air Turning Target System Firing Range.

Information for bidders and specifications may be obtained from the Town Clerk at her office in said town.

Proposals shall be submitted to the Town Clerk, Broadway and Union Road, Cheektowaga, New York 14227 in a sealed envelope, plainly marked on the outside "Bid for Modular Bullet Trap/Containment System and Fixed Air Turning Target System Firing Range".

No bidder may withdraw his bid within forty-five (45) days after the actual date of the opening thereof.

The Town Board reserves the right to consider informal any bid not prepared and submitted in accordance with the provisions of the specifications and contract documents, and may waive any informalities, make an award to other than the low bidder, should it be in the best interest of the Town, or reject any and all bids.

By order of the Town Board of the Town of Cheektowaga, New York.

Alice Magierski
Town Clerk

DATED: November 7, 2011

RESULT: **ADOPTED [UNANIMOUS]**
MOVER: Mary Holtz, Supervisor
SECONDER: James Rogowski, Councilmember
AYES: Holtz, Jaworowicz, Swiatek, Rogowski, Zydel, Markel, Kaznowski



10. RESOLUTION 2011-582

Notice to Bidders - Street Light Standards

Sponsored By: Councilmember Kaznowski, Councilmember Zydel

WHEREAS, it is in order that bids be advertised for the purchase of round tapered aluminum street light standards with tapered elliptical arms, NOW, THEREFORE, BE IT

RESOLVED, that the Town Clerk be directed to publish a Notice to Bidders for the furnishing of round tapered aluminum street light standards with tapered elliptical arms, said Notice to be published in THE CHEEKTOWAGA BEE, AND, BE IT FURTHER

RESOLVED, that sealed bids will be received on the 23rd day of November, 2011 at 11:00 am, Local Time, at a public bid opening to be held in the Council Chambers at the Cheektowaga Town Hall.

NOTICE TO BIDDERS

Sealed proposals will be received and considered by the Town Board of the Town of Cheektowaga on November 23, 2011 at 11:00 am, Local Time, at the Town Hall, corner of Broadway and Union Roads, for the furnishing of round tapered aluminum street light standards and tapered elliptical arms for the Town Sign Maintenance Department.

Information for bidders and specifications may be obtained from the Office of the Town Clerk in Town Hall.

The Town Board reserves the right to consider informal any bid not prepared and submitted in accordance with the provisions of the specifications and contract documents, and may waive any informalities, make an award to other than the low bidder, should it be in the best interest of the Town, or reject any and all bids.

By order of the Town Board of the Town of Cheektowaga, Erie County, New York.

Alice Magierski
Town Clerk

DATED: November 7, 2011

RESULT:	ADOPTED [UNANIMOUS]
MOVER:	Stanley Kaznowski, Councilmember
SECONDER:	Richard Zydel, Councilmember
AYES:	Holtz, Jaworowicz, Swiatek, Rogowski, Zydel, Markel, Kaznowski



11. RESOLUTION 2011-583

Call for Hearing to Amend Vehicle & Traffic Ordinance

Sponsored By: Councilmember Zydel, Councilmember Markel

BE IT RESOLVED, that a public hearing on proposed amendments to Chapter 235 (formerly Chapter 76) of the Code of the Town of Cheektowaga (Vehicle and Traffic) be held on November 21, 2011 at 6:45 P.M. at the Town Hall, 3301 Broadway, Cheektowaga, New York for the purpose of considering the advisability of adopting said amendments, and the Town Clerk is hereby directed to publish the following Notice of Hearing in the CHEEKTOWAGA BEE on the 10th day of November, 2011, said amendments being set forth in the Notice of Hearing.

NOTICE OF PUBLIC HEARING

TAKE NOTICE that the Town Board of the Town of Cheektowaga, Erie County, New York will hold a public hearing at the Town Hall, 3301 Broadway in said Town of Cheektowaga on November 21, 2011 at 6:45 P.M. to consider the advisability of adopting amendments to Chapter 235 of the Code of the Town of Cheektowaga (Vehicle and Traffic); said proposed amendments being as follows:

ARTICLE V. Schedules, Section 235-46, Schedule VII: Stop Intersections, shall be amended by adding thereto the following:

In accordance with the provisions of §235-18, the following described intersections and locations are designated stop intersections:

<u>Stop Sign on</u>	<u>Direction Traffic Stops</u>	<u>At Intersection of</u>
NORM BEALER WAY	South	Losson Road
MELCOURT DR WEST	North	Dawn Road

ARTICLE V. Schedules, Section 235-49, Schedule X: Parking Prohibited in Designated Locations, shall be amended by adding thereto the following:

In accordance with the provisions of §235-34, no person shall park a vehicle at any time upon any of the following described streets or parts of streets:

COLBY STREET - West side: from south curb line of William Street to north curb line of Parker Street

SOUTH COLBY STREET - West side: from south curb line of Parker Street to north curb line of Dingens Street

ARTICLE V. Schedules, Section 235-49, Schedule X: Parking Prohibited in Designated Locations, shall be amended by deleting therefrom the following:

In accordance with the provisions of §235-34, no person shall park a vehicle at any time upon any of the following described streets or parts of streets:

COLBY STREET - East side: from south curb line of William Street to north curb line of Parker

Street

SOUTH COLBY STREET - East side: from south curb line of Parker Street to north curb line of Dingens Street

SOUTH COLBY STREET - West side: 50 feet north of north curb line of Dingens Street

BY ORDER OF THE TOWN BOARD OF THE TOWN OF CHEEKTOWAGA, ERIE COUNTY, NEW YORK.

Dated: November 7, 2011

Alice Magierski
Town Clerk

RESULT:	ADOPTED [UNANIMOUS]
MOVER:	Richard Zydel, Councilmember
SECONDER:	Charles Markel, Councilmember
AYES:	Holtz, Jaworowicz, Swiatek, Rogowski, Zydel, Markel, Kaznowski



12. RESOLUTION 2011-584

Call for Public Hearing - Rezoning Request 5100 Genesee Street

Sponsored By: Councilmember Markel, Councilmember Rogowski

WHEREAS, Christopher J. D'Angelo on behalf of Genesee Transit Holdings VII, LLC has made application and requested the rezoning of a vacant parcel at 5100 Genesee Street from MS- Motor Service to CM- General Commercial for the construction of a 7,515 square foot retail plaza, NOW, THEREFORE BE IT

RESOLVED, that a Public Hearing be held regarding said request under the provisions of the Zoning Law on November 21, 2011 at 6:45 P.M., at the Cheektowaga Town Hall, 3301 Broadway at the corner of Union Road.

Notice of Public Hearing

NOTICE IS HEREBY GIVEN that a Public Hearing will be held by the Town Board of the Town of Cheektowaga, Erie County, New York at the Town Hall in the said Town of Cheektowaga, 3301 Broadway corner of Union Road on the 21st day of November, 2011 at 6:45 o'clock P.M., of said day for the purpose of considering the application of:

Christopher J. D'Angelo / Genesee Transit Holdings VII, LLC
for the rezoning of a vacant parcel at 5100 Genesee Street from MS- Motor Service to CM- General Commercial for the construction of a 7,515 square foot retail plaza.

All parties in interest and citizens will be given an opportunity to be heard in regard to such proposed application.

BY ORDER OF THE TOWN BOARD
Town of Cheektowaga, NY

Alice Magierski, TOWN CLERK

LEGAL DESCRIPTION

ALL THAT TRACT OR PARCEL OF LAND situate in the Town of Cheektowaga, County of Erie, State of New York, being part of lot ALL THAT TRACT OR PARCEL OF LAND, SITUATE IN THE TOWN OF CHEEKTOWAGA, COUNTY OF ERIE AND STATE OF NEW YORK, AND BEING KNOWN AS PART OF LOT NUMBER 75, TOWNSHIP 11, RANGE 7 OF THE HOLLAND LAND COMPANY'S SURVEY, AND DESCRIBED AS FOLLOWS: COMMENCING AT THE CENTERLINE INTERSECTION OF TRANSIT ROAD (S.H. NO. 1334 A-I, PART 4) WITH GENESEE STREET (S.H. NO. 1212, PART 1); THENCE S-70-21'-08-W ALONG THE CENTERLINE OF GENESEE STREET, A DISTANCE OF 243.11 FEET TO A POINT; THENCE N-00-02'-26-E AND PARALLEL WITH THE CENTERLINE OF TRANSIT ROAD A

DISTANCE OF 53.10 FEET TO THE PRINCIPAL POINT OF BEGINNING, BEING THE INTERSECTION OF THE EAST LINE OF LIBER 9548, PAGE 241 WITH THE NORTH LINE OF MAP 77, PARCEL 78, S.H. NO. 1212;
 FROM THE PRINCIPAL POINT OF BEGINNING:
 COURSE 1: THENCE N-00-02'-26-E, A DISTANCE OF 202.09 FEET TO THE POINT AT THE SOUTH LINE OF PERMANENT EASEMENT TO THE NEW YORK STATE DEPARTMENT OF PUBLIC WORKS AS SHOWN ON A MAP 141, PARCEL 153, TRANSIT ROAD, PART 4, S.H. 1334 A-I AND RECORDED IN LIBER 6320, PAGE 38;
 COURSE 2: THENCE S-84-34'-22-E, ALONG THE SOUTH LINE OF PERMANENT EASEMENT TO THE NEW YORK STATE DEPARTMENT OF PUBLIC WORKS AS SHOWN ON A MAP 141, PARCEL 153, TRANSIT ROAD, PART 4, S.H. 1334 A-I AND RECORDED IN LIBER 6320, PAGE 38, A DISTANCE OF 31.41 FEET TO A POINT ;
 COURSE 3: THENCE N-00-02'-26-E, A DISTANCE OF 35.71 FEET TO A POINT;
 COURSE 4: THENCE S-89-57'-34-E, A DISTANCE OF 112.62 FEET TO A POINT;
 COURSE 5: THENCE S-00-02'-26-W, 46.33 FEET TO A POINT;
 COURSE 6: THENCE S-84-34'-22-E, 15.07 FEET TO THE POINT AT WESTERLY LINE OF TRANSIT ROAD (WIDTH VARIES);
 COURSE 7: THENCE S-00-02'-26-W, ALONG A WESTERLY RIGHT OF WAY OF TRANSIT ROAD 100.28 FEET TO A POINT;
 COURSE 8: THENCE WESTERLY S-20-18'-28-W, 36.82 FEET TO THE POINT AT THE NORTHERLY LINE OF GENESEE STREET (WIDTH VARIES);
 COURSE 9: THENCE S-70-21'-08-W, ALONG THE NORTHELY LINE OF GENESEE STREET (WIDTH VARIES) 212.92 FEET TO THE PRINCIPAL POINT OF BEGINNING.
 CONTAINING 31041.65 SQ.FT. OR 0.71 MORE OR LESS ACRES.

Attachments:

Legal Description 5100 Genesee Street_MS to CM (DOC)

RESULT: ADOPTED [UNANIMOUS]
MOVER: Charles Markel, Councilmember
SECONDER: James Rogowski, Councilmember
AYES: Holtz, Jaworowicz, Swiatek, Rogowski, Zydel, Markel, Kaznowski



13. RESOLUTION 2011-585

Accept Site Plan - 2720 Union Road- Dr. Legarreta

Sponsored By: Councilmember Markel, Councilmember Rogowski

WHEREAS, pursuant to the Zoning Law of the Town of Cheektowaga, the Planning Board reviews various development review applications for site plans, rezonings, special permits and realty subdivisions and renders its recommendation concerning the compatibility of such application with the zoning regulations, Town Master Plan and neighborhood character, AND

WHEREAS, the Town Board, pursuant to the Zoning Law of the Town of Cheektowaga, is required to affirm, modify or reject any recommendation submitted to it by the Planning Board, AND

WHEREAS, a development review application and site plan was submitted by Dean Sutton Architects for the construction of a 2,500 square foot building addition to an existing opticians office at 2720 Union Road, AND

WHEREAS, the Town of Cheektowaga Planning Board at its meeting of September 8, 2011 is recommending the approval of the site plan, AND

WHEREAS, this Town Board has reviewed the development review application and recommendations made by the Planning Board, NOW THEREFORE, BE IT

RESOLVED, that this Town Board determines that the project site plan is acceptable subject to :

1. The Town Engineer reviewing and approving the grading/drainage plan.

Attachments:

Site Plan (PDF)

PLANNING BOARD MINUTES SEPTEMBER2011 (PDF)

RESULT: ADOPTED [UNANIMOUS]

MOVER: Charles Markel, Councilmember

SECONDER: James Rogowski, Councilmember

AYES: Holtz, Jaworowicz, Swiatek, Rogowski, Zydel, Markel, Kaznowski



14. RESOLUTION 2011-586

Accept Site Plan - 125 Gardenville Pkwy. - U.S. Foodservice

Sponsored By: Councilmember Markel, Councilmember Rogowski

WHEREAS, pursuant to the Zoning Law of the Town of Cheektowaga, the Planning Board reviews various development review applications for site plans, rezonings, special permits and realty subdivisions and renders its recommendation concerning the compatibility of such application with the zoning regulations, Town Master Plan and neighborhood character, AND

WHEREAS, the Town Board, pursuant to the Zoning Law of the Town of Cheektowaga, is required to affirm, modify or reject any recommendation submitted to it by the Planning Board, AND

WHEREAS, a development review application and site plan was submitted by Michael Heburn/U.S. Foodservice for the construction of a parking area expansion for (24) twenty four employee vehicles at 125 Gardenville Parkway, AND

WHEREAS, the Town of Cheektowaga Planning Board at its meeting of October 13, 2011 is recommending the approval of the site plan, AND

WHEREAS, this Town Board has reviewed the development review application and recommendations made by the Planning Board, NOW THEREFORE, BE IT

RESOLVED, that this Town Board determines that the project site plan is acceptable subject to :

1. The addition of concrete curbing to the interior islands of the new parking area.
2. The Town Engineer reviewing and approving the drainage/grading plan.

Attachments:

OCTOBER 13TH2011PLANNING BOARDMINUTES (PDF)

RESULT: ADOPTED [UNANIMOUS]

MOVER: Charles Markel, Councilmember

SECONDER: James Rogowski, Councilmember

AYES: Holtz, Jaworowicz, Swiatek, Rogowski, Zydel, Markel, Kaznowski



15. RESOLUTION 2011-587

Authorize Supervisor to Sign Contracts for Concerts and Special Events for 2012

Sponsored By: Supervisor Holtz, Councilmember Rogowski

BE IT RESOLVED that subject to approval by the Town Attorney, Supervisor Mary F. Holtz be and hereby is authorized to sign contracts between the Town of Cheektowaga, performers, sponsors and recurring vendors for concerts and special events to be held during the year 2012.

FUNDING SOURCE:

0100-7140-4503

0100-7140-4491

0100-7620-4491

0100-7620-4685

0100-7550-4374

RESULT:	ADOPTED [UNANIMOUS]
MOVER:	Mary Holtz, Supervisor
SECONDER:	James Rogowski, Councilmember
AYES:	Holtz, Jaworowicz, Swiatek, Rogowski, Zydel, Markel, Kaznowski



16. RESOLUTION 2011-588

Authorize Supervisor to Execute Memorandum with Erie County Health Department

Sponsored By: Supervisor Holtz, Councilmember Jaworowicz

WHEREAS, the Town of Cheektowaga is the owner of the Cheektowaga Recreation Center building located at 2600 Harlem Road in the Town of Cheektowaga, and

WHEREAS, the County of Erie Health Department has requested that it be allowed to use the Cheektowaga Recreation Center to serve as a Point of Dispensing in the event that mass prophylaxis/immunization is necessary to address public health situations, and

WHEREAS, the Erie County Health Department has prepared and submitted to the Town of Cheektowaga for our approval a Memorandum of Agreement which spells out the terms of use and liability responsibility, and

WHEREAS, this Board is willing to cooperate with the County of Erie Health Department for the safety of the public, NOW, THEREFORE, BE IT

RESOLVED, that the Supervisor be and hereby is authorized and directed to execute the aforementioned Memorandum of Agreement with the Erie County Health Department on behalf of the Town.

RESULT:	ADOPTED [UNANIMOUS]
MOVER:	Mary Holtz, Supervisor
SECONDER:	Patricia Jaworowicz, Councilmember
AYES:	Holtz, Jaworowicz, Swiatek, Rogowski, Zydel, Markel, Kaznowski



17. RESOLUTION 2011-589

Youth & Recreation 2012 Program Fees

Sponsored By: Councilmember Zydel, Councilmember Rogowski

BE IT RESOLVED that the following program fees be and hereby are established in the Department of Youth & Recreational Services:

FEEES IN (\$0.00) DENOTE 2011 FEEES

RESIDENT DISCOUNT CARDS

CHILDREN	(7 - 15 YEARS OF AGE)	\$5.00	(\$5)
ADULT	(16 - 59 YEARS OF AGE)	\$7.00	(\$7)
SENIORS	(60 YEARS OF AGE AND OLDER)	FREE	(FREE)

CAMP DARTWOOD

SUMMER	RESIDENT	NON-RESIDENT
PER CHILD ALL 6 WEEKS	\$ 625 (\$607)	\$ 749 (\$728)
PER CHILD WEEKLY \$ 112	(\$106)	\$ 138 (\$134)
SECOND CHILD ALL 6 WEEKS	\$ 607 (\$590)	\$ 729 (\$708)
SECOND CHILD WEEKLY	\$ 107 (\$104)	\$ 132 (\$129)
THREE (3) DAYS PER WEEK	\$ 100 (\$ 98)	\$109 (\$118)

CAMP FLAMINGO/TEEN CLUB

SUMMER	RESIDENT	NON-RESIDENT
PER CHILD ALL 6 WEEKS	\$ 625 (\$607)	\$749 (\$728)
PER CHILD WEEKLY \$ 112	(\$109)	\$ 138 (\$134)
SECOND CHILD ALL 6 WEEKS	\$ 607 (\$590)	\$ 729 (\$708)
SECOND CHILD WEEKLY	\$ 107 (\$104)	\$ 132 (\$129)
THREE (3) DAYS PER WEEK	\$ 100 (\$98)	\$122 (\$118)

YOUTH IN TRAINING

RESIDENT	NON-RESIDENT
\$180 (\$175)	\$212 (\$207)

CAMP JI-IK-DO-WAH-GAH/CAMP CRABAPPLE

SUMMER	RESIDENT	NON-RESIDENT
PER CHILD ALL 6 WEEKS	\$ 607 (\$590)	\$ 749 (\$728)
PER CHILD WEEKLY \$ 112	(\$109)	\$ 138 (\$134)
SECOND CHILD ALL 6 WEEKS	\$ 584 (\$567)	\$ 729 (\$708)
SECOND CHILD WEEKLY	\$ 107 (\$104)	\$ 132 (\$129)
THREE (3) DAYS PER WEEK	\$ 100 (\$ 98)	\$109 (\$118)

ADAPTED RECREATION PROGRAM

	RESIDENT	NON-RESIDENT
OCTOBER - APRIL	\$ 217 (\$211)	\$ 251 (\$244)

SPECIAL OLYMPICS

	\$ 30 (\$30)	\$30 (\$30)
--	--------------	-------------

TINY TOTS

SUMMER	RESIDENT	NON-RESIDENT
PER CHILD	\$57 (\$56)	\$64 (\$63)
SECOND CHILD	\$52 (\$51)	\$59 (\$58)

THREE TO GET READY**(Summer Fun for 3's & 4's)**

SUMMER	RESIDENT	NON-RESIDENT
PER CHILD	\$52 (\$51)	\$59 (\$58)
SECOND CHILD	\$47 (\$46)	\$54 (\$53)

BREAK CLUBS

	RESIDENT	NON-RESIDENT
4 DAYS	\$108 (\$108)	\$120 (\$120)
5 DAYS	\$135 (\$135)	\$150 (\$150)
SINGLE DAY	\$27 (\$27)	\$30 (\$30)

**HOME WORK HELPERS
PER HOUR**

	RESIDENT	NON-RESIDENT
	\$7 (\$7)	\$7 (\$7)

GIRL POWER

	RESIDENT	NON-RESIDENT
	\$40 (\$40)	\$50 (\$50)

GYMNASTICS (Beginners) Fall/Winter/Spring/Summer

2 DAY	RESIDENT	NON-RESIDENT
PER CHILD	\$65 (\$65)	\$75 (\$75)
SECOND CHILD	\$60 (\$59)	\$70 (\$69)

SUMMER (1 DAY)		
PER CHILD	\$28 (\$39)	\$38 (\$49)
SECOND CHILD	\$23 (\$35)	\$33 (\$33)

TINY TUMBLERS

SUMMER 3&4YR OLD	RESIDENT	NON-RESIDENT
PER CHILD	\$45 (\$39)	\$55 (\$49)
SECOND CHILD	\$40 (\$35)	\$55 (\$45)

TINY TUMBLERS

FALL/WINTER/SPRING	RESIDENT	NON-RESIDENT
SECOND CHILD	\$45 (\$45)	\$55 (\$55)
	\$40 (\$40)	\$50 (\$50)

ADVANCED I & II GYMNASTICS

SUMMER	RESIDENT	NON-RESIDENT
PER CHILD	\$70 (\$70)	\$80 (\$80)
SECOND CHILD	\$65 (\$65)	\$75 (\$75)

INTRO TO ADVANCED GYMNASTICS

PER CHILD	\$65 (\$65)	\$75 (\$75)
-----------	-------------	-------------

SECOND CHILD	\$60	(\$59)	\$70	(\$69)
ADVANCED GYMNASTICS				
PRACTICES (per class):				
OPEN TUMBLING	\$ 5	(\$ 5)	\$ 5	(\$ 5)
OPEN WORKOUT (1 ½ HOURS)	\$ 8		\$ 8	
JUST A BACK HANDSPRING & FUN WITH FLOOR EXERCISE				
	RESIDENT		NON-RESIDENT	
PER CHILD	\$60	(\$45)	\$70	(\$55)
2 ND CHILD	\$55	(\$39)	\$65	(\$49)
PILATES & FLEXIBILITY				
	RESIDENT		NON-RESIDENT	
	\$20	--	\$30	--
	\$2 PER CLASS		\$3 PER CLASS	
ADULT EXERCISE (CLEVELAND HILL)				
2 Sessions Fall/Winter (each session)				
	RESIDENT		NON - RESIDENT	
	FALL	\$60	FALL	\$70
	WINTER	\$70	WINTER	\$80
	(\$125 \$100 EARLY BIRD FEE - \$3 PER DAY)			
SWIMMING				
	RESIDENT		NON-RESIDENT	
SUMMER				
YOUTH	\$38	(\$37)	\$48	(\$47)
SECOND CHILD	\$35	(\$34)	\$45	(\$44)
PARENT/INFANT	\$28	(\$27)	\$38	(\$37)
SECOND CHILD	\$25	(\$24)	\$35	(\$34)
PRE-SCHOOL	\$28	(\$27)	\$38	(\$37)
SECOND CHILD	\$25	(\$24)	\$35	(\$34)
WATER AEROBICS	\$35	(\$34)	\$45	(\$44)
ADULT		\$35 (\$34)	\$45	(\$44)
GUARD START	\$38	(\$37)	\$48	(\$47)
WATER SLIDE	\$ 1	(\$1)	\$ 1	(\$1)
DAILY USER FEE (Maryvale/Dingens)	\$ 7	(\$7)	\$ 7	(\$7)
DAILY USER FEE (Town Pool)	\$ 7	(\$7)	\$ 7	(\$7)
EVENING SWIM LESSONS	\$38		\$48	
FALL 2011/ WINTER 2012				
YOUTH	\$37	(\$36)	\$47	(\$46)
SECOND CHILD	\$34	(\$33)	\$43	(\$43)
OPEN/ FAMILY (LESS DAYS)	\$36	(\$35)	\$46	(\$45)
LIFEGUARD TRAINING				
	\$144	(\$143)	\$184	(\$183)
Pool utilization for instructional groups will be charged \$30 per hour for 10 or less patrons. Five dollars more will be charged for every person above 10 in number. Rental availability subject to approval by the Pool Director.				
INSTRUCTIONAL TENNIS				
	RESIDENT		NON-RESIDENT	
SUMMER				
YOUTH	\$33	(\$32)	\$43	(\$42)
ADULT BEGINNERS	\$25	(\$36)	\$30	(\$46)

ADULT INT/ADV	\$0	(\$20)	\$35	(\$25)
---------------	-----	--------	------	--------

WEE THREE-TWICE THE FUN 2012-13**RUNS - 2ND WEEK OF SEPT TILL END OF MAY BEFORE MEMORIAL DAY**

FALL/ WINTER/SPRING	RESIDENT	NON-RESIDENT
PER CHILD	\$455 (\$435)	\$495 (\$460)
SECOND CHILD	\$425 (\$410)	\$465 (\$435)

TEA TIME FOR TWO 2011

FALL/ WINTER	RESIDENT	NON-RESIDENT
PER CHILD	\$78 (\$71)	\$88 (\$81)
SECOND CHILD	\$68 (\$66)	\$78 (\$76)

ART CAMP

RESIDENT	NON-RESIDENT
\$77 (\$77)	\$87 (\$87)

CHEER CAMP

RESIDENT	NON-RESIDENT
\$57 (\$57)	\$62 (\$62)

PUBLIC SKATE

FALL/WINTER		
GENERAL ADMISSION	\$5	(\$4)
	W/ RESIDENT DISCOUNT CARD	
CHILDREN 3 AND UNDER	FREE	(FREE)
CHILDREN 4 TO 15	\$2	(\$2)
ADULTS 16 AND UP	\$3	(\$3)
BIRTHDAY PARTIES	\$8.00 PER PERSON	(\$7.50)
SCHOOL TIME SKATES	\$4.00 PER PERSON	(\$3)
SENIOR CITIZENS	\$2	(\$2)

LEARN TO SKATE

FALL/ WINTER		
	RESIDENT	NON-RESIDENT
PER INDIVIDUAL	\$50 (\$48)	\$70 (\$68)

ICE HOCKEY

FALL/ WINTER	RESIDENT		NON-RESIDENT
	HOUSE	TRAVEL	HOUSE TRAVEL
NOVICE	\$410 (\$390)	N/A	\$610(\$570) N/A
MITE	\$410 (\$430)	\$575 (\$550)	\$610(\$550) \$755 (\$755)
SQUIRT	\$505 (\$490)	\$635 (\$610)	\$705(\$685) \$835(\$815)
PEE WEE	\$555 (\$540)	\$685 (\$685)	\$755(\$735) \$885 (\$865)
BANTAM	\$605 (\$590)	\$735 (\$770)	\$805(\$735) \$935 (\$915)
MIDGET	\$675 (\$660)	\$545 (\$520)	\$875(\$855) \$745 (\$725)

--\$100 DISCOUNT FOR BALANCE(S) PAID IN FULL BY OCTOBER 15, 2012
 --ALL COACHES WILL RECEIVE A \$100.00 REDUCTION FOR ONE CHILD
 --SECOND CHILD ENROLLED FROM A FAMILY \$50.00 REDUCTION
 --THIRD CHILD ENROLLED FROM A FAMILY \$100.00 REDUCTION
 --FOURTH CHILD ENROLLED FROM A FAMILY \$150.00
 -THERE WILL BE A \$100.00 LATE FEE FOR ANYONE NOT PAID IN FULL BY

NOVEMBER 30TH OF EACH SEASON
-A \$200 NON-REFUNDABLE DEPOSIT IS REQUIRED TO REGISTER

ICE RENTALS

FALL/ WINTER

PER HOUR

PRIME TIME \$180 (\$175) 5:00pm-11:00pm
M-F

All day Sat and Sun and Holidays

NON-PRIME \$155 (\$150) 8:00am- 5:00pm
M-F - Except holidays**SPORT COURT RENTALS**

PER HOUR

\$75 (\$75)

PER HOUR AND HALF

\$95 (\$95)

PER 2 HOURS

\$130 (\$120)

INLINE HOCKEY

SUMMER

RESIDENT

NON-RESIDENT

YOUTH PARTICIPANT

\$75 (\$75)

\$105 (\$105)

NOVICE

\$20 (\$20)

\$30 (\$30)

ADULT TEAM

\$835 (\$815)

\$895 (\$875)

JUNIOR A

\$25

\$55

** ADULT INLINE TEAMS ARE RESPONSIBLE FOR PAYMENT OF REFEREES
PRIOR TO THE START OF EACH GAME**

**\$150 for Jerseys (Optional)

HIGH SCHOOL IN LINE \$615 (\$815) \$675 (\$875)

FLOOR HOCKEY

YOUTH PARTICIPANT

RESIDENT
\$ 55NON-RESIDENT
\$ 70

ADULT/ MIDGET TEAM

\$ 550

\$595

** ADULT/MIDGET FLOOR HOCKEY TEAMS ARE RESPONSIBLE FOR PAYMENT
OF REFEREES PRIOR TO THE START OF EACH GAME**

YOUTH SOCCER

SUMMER

RESIDENT

NON-RESIDENT

CHILD

\$61 (\$58)

\$77 (\$74)

ADULT INDOOR SOCCER 2011

ADULT, JUNIORS, MIDGET

\$560 (\$450)

\$625 -

***\$50 DISCOUNT FOR TEAMS NOT IN NEED OF JERSEYS
(ADULT, JUNIORS AND MIDGET TEAMS PAY THE REFREE FEES PRIOR TO THE
START OF THE GAME)

ALL STAR-ALL SPORTS

\$65 (\$65)

\$75 (\$75)

START SMART SOCCER

\$48 (\$45)

\$63 (\$60)

START SMART BASEBALL

\$55 (\$55)

\$65 (\$65)

START SMART BASKETBALL

\$55 (\$55)

\$65 (\$65)

YOUTH BASKETBALL

FALL/ WINTER	RESIDENT	NON-RESIDENT
PER PARTICIPANT	\$45 (\$40)	\$55 (\$50)

ADULT BASKETBALL

PER TEAM	\$125 (\$100)	\$150 (\$125)
----------	---------------	---------------

**ALL RESIDENT TEAMS MUST SUPPLY ID'S FOR EVERY PLAYER

**TEAMS ARE RESPONSIBLE FOR PAYING REFEREE FEES EACH WEEK

VOLLEYBALL (teams pay referee fees each week)

INDOOR FALL/ WINTER SESSIONS I & II (Monday, Thursday & Friday)

\$200 per team (resident rate) \$250 per team (non resident rate)

SATURDAY League \$250 per team (resident rate) \$280 per team (non resident rate)

SUMMER

OUTDOOR LEAGUE \$125 per team (resident rate) \$150 per team (non-resident rate)

**ALL RESIDENT TEAMS MUST SUPPLY ID'S FOR EVERY PLAYER

**TEAMS ARE RESPONSIBLE FOR PAYING REFEREE FEES EACH WEEK

DIAMOND PERMITS

SUMMER (per 2 hour time block)	RESIDENT	NON-RESIDENT
NO LIGHTS	\$50 (\$50)	\$70 (\$70)
LIGHTS	\$80 (\$80)	\$95 (\$95)

13 WEEK SERIES

NO LIGHTS	\$450 (\$450)	\$675 (\$675)
LIGHTS	\$750 (\$750)	\$925 (\$925)

Additional games added to 13-week series are charged at the regular 2-hour block rate

SOCCER / FOOTBALL FIELD RENTAL

	RESIDENT	NON-RESIDENT
PER TWO HOUR TIME BLOCK	\$70 (\$60)	\$85 (\$75)

VOLLEYBALL COURT RENTAL

	RESIDENT	NON-RESIDENT
1 COURT PER TWO HOUR BLOCK	\$50 (\$50)	\$70 (\$70)

GYM RENTAL

	RESIDENT	NON-RESIDENT
2 HOUR BLOCK	\$30 (\$30)	\$50 (\$50)

TENNIS COURT RENTAL

	RESIDENT	NON-RESIDENT
1 HOUR BLOCK	\$15 (\$15)	\$30 (\$30)

ADULT SOFTBALL LEAGUES

SUMMER		LEAGUE RESIDENT	LEAGUE NON-RESIDENT	
CO-ED		\$345 (\$345)	\$425 (\$425)	
WOMEN'S		\$345 (\$345)	\$425 (\$425)	
MEN'S LEISURE		\$345 (\$345)	\$425 (\$425)	MEN'S
OVER 40	\$345 (\$345)	\$425 (\$425)		
OPEN MEN'S		\$345 (\$345)	\$425 (\$425)	
FALL - ALL LEAGUES - RESIDENT-		\$190 (\$180)	\$190 (\$180)	

**ALL TEAMS ARE RESPONSIBLE FOR PAYING THE UMPIRE FEES EACH WEEK

**THE \$20 ASA FEE WILL BE INCLUDED WITH THE REGISTRATION FEE

**ALL RESIDENT TEAMS MUST SUPPLY ID'S FOR EVERY PLAYER

KICKBALL LEAGUES

SUMMER	LEAGUE RESIDENT	LEAGUE NON-RESIDENT
(CO-ED TUES)	\$250.00	\$250.00

SUMMER TEEN PROGRAM

WEEKLY	RESIDENTS	NON-RESIDENTS
ONE CHILD	\$101 (\$95)	\$120 (\$109)
SECOND CHILD	\$96 (\$90)	\$116 (\$100)

6 WEEKS	RESIDENTS	NON-RESIDENTS
ONE CHILD	\$601 (\$570)	\$715 (\$630)
SECOND CHILD	\$571 (\$540)	\$691 (\$600)

*FIRST WEEK ONLY - one child	\$94	\$113
	89	109

*3 day week

CULTURAL CENTER (BAND SHELL) LOCATED IN TOWN PARK

THE RENTAL FEE IS FOR FOUR HOURS ANY TIME PRIOR TO OR AFTER THE SPECIFIED RENTAL TIME THE RENTER IS RESPONSIBLE FOR THE COSTS OF KEEPING STAFF ON.

RESIDENTS

\$400 for a four hour period Additional hours before or after the specified rental time will be billed at \$125 per hour.

NON-RESIDENTS

\$800 for a four hour period Additional hours before or after the specified rental time will be billed at \$195 per hour.

RESULT:	ADOPTED [UNANIMOUS]
MOVER:	Richard Zydell, Councilmember
SECONDER:	James Rogowski, Councilmember

AYES: Holtz, Jaworowicz, Swiatek, Rogowski, Zydel, Markel, Kaznowski



18. RESOLUTION 2011-590

Purchase of Surveillance Cameras

Sponsored By: Holtz, Jaworowicz, Swiatek, Rogowski, Zydel, Markel, Kaznowski

WHEREAS, the Cheektowaga Town Board and Cheektowaga Police Department, are working together to do all that is possible to make its neighborhoods and parks safer for its residents and visitors, AND

WHEREAS, in an effort to monitor activities in and out of Cheektowaga Town Park, the Police Department wishes to purchase video surveillance cameras, AND

WHEREAS, SimplexGrinnell, LP has the New York State Contract (Contract PT63104, Award 20191, Group 77201) for the video surveillance equipment, and

WHEREAS, SimplexGrinnell, LP has submitted a proposal to the Town for said equipment at a total cost of \$64,225.00, and

WHEREAS, funds for these video surveillance cameras are available in the Police Department Asset Forfeiture budget (line item 600-0600-0881) and the Facilities Department budget (line item 100-7100-4451), NOW, THEREFORE, BE IT

RESOLVED, that the Town Board hereby authorizes the purchase of six (6) cameras for in Town Park and one (1) surveillance van video system, together with ancillary equipment, installation and licensing fees as per the SimplexGrinnell Quotations dated 11/01/2011 for the total cost of \$64,225.00 from:

SimplexGrinnell, LP
6850 Main Street, Suite 3
Amherst, NY 14221

, and BE IT FURTHER

RESOLVED, that funding for said cameras, installation and ancillary equipment shall be appropriated as follows from the following budget line items

\$43,575.00	line item #600-0600-0881
\$6,500.00	line item #100-7110-4451
\$14,150.00	line item #600-0600-0881

, and BE IT FURTHER

RESOLVED, that the Supervisor be and hereby is authorized and directed to execute agreements with SimplexGrinnell, LP and any and all other documents necessary to effectuate the purchase and installation of the aforementioned video surveillance cameras.

RESULT:	ADOPTED [UNANIMOUS]
MOVER:	Mary Holtz, Supervisor

SECONDER: Patricia Jaworowicz, Councilmember

AYES: Holtz, Jaworowicz, Swiatek, Rogowski, Zydel, Markel, Kaznowski



19. RESOLUTION 2011-591

Unsafe-Unsecured/2523 Genesee Street

Sponsored By: Councilmember Markel, Councilmember Kaznowski

WHEREAS, Town of Cheektowaga Law for the Administration and Enforcement of the Codes of New York State; and the Property Maintenance Code of New York State require that all vacant structures and premises shall be maintained in clean, safe, secure and sanitary conditions so as not to cause a blighting problem or adversely affect the public health or safety and all nuisances abated, AND

WHEREAS, the Town of Cheektowaga has received notification of an unsafe structure and premises located at 2523 Genesee Street, Cheektowaga, New York SBL# 91.77-2-2 that is a danger to the safety of others, and records kept by the Assessors Office identify Richard H. Filipowicz, 86 Harlem Road, Buffalo, New York 14224, as the owner AND

WHEREAS, an inspection of such premises was conducted at 2523 Genesee Street, by the Housing and Neighborhood Preservation Office, AND

WHEREAS, such inspection found the premises to be deteriorated, vacant, a hazard, and a danger to the safety and well being of others, AND

WHEREAS, the Town of Cheektowaga Housing and Neighborhood Preservation Office properly notified the property owner in accordance with the Town of Cheektowaga Law for the Administration and Enforcement of the Codes of New York State, and the owner failed to take actions to safeguard the premises, AND

WHEREAS, these conditions require the Town of Cheektowaga Housing and Neighborhood Preservation Office to take immediate steps to safeguard the premises to protect the health and safety of others and abate all nuisances, NOW, THEREFORE BE IT

RESOLVED, that pursuant to Section 70-7A.(5) and Section 70-8 of the Town of Cheektowaga Law for the Administration and Enforcement of the Codes of New York State that the vacant structure premises be safeguarded and all nuisances abated; and all costs incurred be assessed against the property hereinbefore described.

RESULT:	ADOPTED [UNANIMOUS]
MOVER:	Charles Markel, Councilmember
SECONDER:	Stanley Kaznowski, Councilmember
AYES:	Holtz, Jaworowicz, Swiatek, Rogowski, Zydel, Markel, Kaznowski



20. RESOLUTION 2011-592

Demolition of Accessory Structure/1616 E Delavan

Sponsored By: Councilmember Markel, Councilmember Kaznowski

WHEREAS, Town of Cheektowaga Law for the Administration and Enforcement of the Codes of New York State; and the Property Maintenance Code of New York State require that all vacant structures and premises shall be maintained in clean, safe, secure and sanitary conditions so as not to cause a blighting problem or adversely affect the public health or safety and all nuisances abated, AND

WHEREAS, the Town of Cheektowaga has received notification of an unsafe structure and premises located at 1616 E Delavan Avenue, Cheektowaga, New York SBL# 90.76-4-29 that is a danger to the safety of others, and records kept by the Assessors Office identify alan Pilarski, 22 Starcrest Drive, Cheektowaga, New York 14225, as the owner AND

WHEREAS, an inspection of such premises was conducted at 1616 E Delavan Avenue, by the Housing and Neighborhood Preservation Office, AND

WHEREAS, such inspection found the premises to be deteriorated, vacant, a hazard, and a danger to the safety and well being of others, AND

WHEREAS, the Town of Cheektowaga Housing and Neighborhood Preservation Office properly notified the property owner in accordance with the Town of Cheektowaga Law for the Administration and Enforcement of the Codes of New York State, and the owner failed to take actions to safeguard the premises, AND

WHEREAS, these conditions require the Town of Cheektowaga Housing and Neighborhood Preservation Office to take immediate steps to safeguard the premises to protect the health and safety of others and abate all nuisances, NOW, THEREFORE BE IT

RESOLVED, that pursuant to Section 70-7A.(5) and Section 70-8 of the Town of Cheektowaga Law for the Administration and Enforcement of the Codes of New York State that the vacant structure premises be safeguarded and all nuisances abated; and all costs incurred be assessed against the property hereinbefore described.

RESULT:	ADOPTED [UNANIMOUS]
MOVER:	Charles Markel, Councilmember
SECONDER:	Stanley Kaznowski, Councilmember
AYES:	Holtz, Jaworowicz, Swiatek, Rogowski, Zydel, Markel, Kaznowski



21. RESOLUTION 2011-593

Hire/Termination of Part-Time/Seasonal Employees

Sponsored By: Councilmember Swiatek, Supervisor Holtz

BE IT RESOLVED, that the following individual be and hereby is hired as a **SEASONAL EMPLOYEE**, not to exceed five (5) months in a calendar year, in the department listed and in compliance with Civil Service Laws and Regulations as well as the provisions of the Town's collective bargaining agreement between the Town of Cheektowaga and the Town of Cheektowaga Employees Association:

ASSESSOR'S OFFICE Clerk \$8.50/hour effective 12/1/11
Kristen M. Murphy, Sloan, New York

BE IT RESOLVED, that the following individuals be and hereby are hired as **PART-TIME EMPLOYEES** in the departments listed, not to exceed nineteen (19) hours on a weekly basis, in compliance with Civil Service Laws and Regulations as well as the provisions of the Town's collective bargaining agreement between the Town of Cheektowaga and the Town of Cheektowaga Employees Association:

POLICE DEPARTMENT School Crossing Guard \$8.50/hour effective 10/18/11
Brenda L. Benkleman, Cheektowaga, New York

POLICE DEPARTMENT Dog Control Officer \$10.00/hour effective 10/31/11
Adam T. Paradowski, Cheektowaga, New York

BE IT RESOLVED, that the following seasonal and/or part-time employees be and hereby are terminated as listed:

RECORDS MANAGEMENT
Ian Trapper effective 10/5/11

FACILITIES DEPARTMENT
Justin Borowski effective 4/3/11

EMPLOYEE RELATIONS
Megan Latshaw effective 10/6/11

POLICE DEPARTMENT
John F. Drennen effective 9/8/11
Sandie Kobee effective 11/1/11
Roberta Paul effective 10/23/11

SANITATION DEPARTMENT
Dean Mertowski effective 10/15/11
Steven Krystyniak effective 10/15/11
Thomas Buil effective 10/15/11
Kevin Adamczyk effective 10/15/11
Justin Adamczyk effective 10/15/11

SEWER MAINTENANCE

Jacob Latshaw effective 10/23/11

Motion by Councilmember Kaznowski; Seconded by Councilmember Rogowski to waive the reading of names for the following resolutions: 2011-593; 2011-594 and 2011-595. Motion Carried.

RESULT: ADOPTED [UNANIMOUS]
MOVER: Jeff Swiatek, Councilmember
SECONDER: Mary Holtz, Supervisor
AYES: Holtz, Jaworowicz, Swiatek, Rogowski, Zydel, Markel, Kaznowski



22. RESOLUTION 2011-594

Youth & Recreation Transfers

Sponsored By: Councilmember Zydel, Councilmember Rogowski

BE IT RESOLVED that the individuals listed below be and hereby are hired and/or transferred, as indicated, in the Department of Youth & Recreational Services, effective immediately:

Recreation Instructor - 7310.1804 - \$11.50 - Regular Part-time

Sherry Maran

Recreation Attendant - 7140.1639 & 7140.1611 - \$7.50 - Regular Part-time

Eric Farinacci	14225
Joseph Swierczynski	14206

RESULT:	ADOPTED [UNANIMOUS]
MOVER:	Richard Zydel, Councilmember
SECONDER:	James Rogowski, Councilmember
AYES:	Holtz, Jaworowicz, Swiatek, Rogowski, Zydel, Markel, Kaznowski



23. RESOLUTION 2011-595

Youth & Recreation Terminations

Sponsored By: Councilmember Zydel, Councilmember Rogowski

BE IT RESOLVED that the individuals listed below be and herby are terminated in the Department of Youth & Recreational Services, effective as indicated:

Ben Dunning	10/1/11	14225
Spencer Calos	8/12/11	14227
Andrew Chruscicki	8/24/11	14225
Becky Gworek	8/24/11	14227
Danielle Malicki	9/2/11	14227
Mark Marek	8/31/11	14227
Caitlin Rieck	8/25/11	14225
Naomi Snyder	8/28/11	14225
Tiffany Wheeler	3/23/11	14225

RESULT:	ADOPTED [UNANIMOUS]
MOVER:	Richard Zydel, Councilmember
SECONDER:	James Rogowski, Councilmember
AYES:	Holtz, Jaworowicz, Swiatek, Rogowski, Zydel, Markel, Kaznowski

V. Communications

A. Departmental Communications

1. 2012 Town of Cheektowaga Adopted Budget
2. Supervisor's Statement of Funds - September 2011
3. Building Permits - October 2011
4. Minutes: Cheektowaga Traffic Safety Commission - September 20, 2011
5. Minutes: Cheektowaga Conservation Advisory Council - October 6, 2011
6. Minutes: Cheektowaga Planning Board - October 13, 2011
7. Minutes: Cheektowaga Public Library Board of Trustees - October 19, 2011
8. Minutes: Town Environmental Advisory Committee - November 2, 2011

B. General Communications

1. Notice of Claim: Justin Barends Vs. Town of Cheektowaga
2. Notice of Claim: Denis Ducotey Vs. Town of Cheektowaga
3. Notice of Claim: GEICOas Subrogee for Michelle Bane Vs. Town of Cheektowaga
4. Notice of Claim: Jeffrey Place Vs. Town of Cheektowaga
5. Notice of Claim: Jacqueline Robles Vs. Town of Cheektowaga
6. Notice of Claim: Pauline Scordato Vs. Town of Cheektowaga
7. Notice of Claim: Heather Shelten Vs. Town of Cheektowaga
8. Notice of Claim: Daniel Swiatek Vs. Town of Cheektowaga

VI. Comments

A. Supervisor's Comments

B. Councilmember's Comments

C. Public Comments

VII. Adjournment

Motion by Supervisor Holtz; Seconded by Councilmember Swiatek to adjourn the Meeting in Memory of John Marriott's wife, Kathleen Marriott.

Alice Magierski, Town Clerk

CERTIFICATION

"WE GENESEE ENGINEERING PLANNING SURVEYING P.C., THE UNDERSIGNED, DO HEREBY CERTIFY TO STARBUCKS CORPORATION, A WASHINGTON CORPORATION, AND ITS AFFILIATES AND STEWART TITLE GUARANTY COMPANY, THAT THIS PLAT REPRESENTS A SURVEY MADE BY ME OR UNDER MY SUPERVISION ON THE DAY OF FEBRUARY 28, 2008, OF THE REAL PROPERTY DESCRIBED AS FOLLOWS:

ALL THAT TRACT OR PARCEL OF LAND, SITUATE IN THE TOWN OF CHEEKTOWAGA, COUNTY OF ERIE AND STATE OF NEW YORK, AND BEING KNOWN AS PART OF LOT NUMBER 75,

TOWNSHIP 11, RANGE 7 OF THE HOLLAND LAND COMPANY'S SURVEY, AND DESCRIBED AS FOLLOWS:

COMMENCING AT THE CENTERLINE INTERSECTION OF TRANSIT ROAD (S.H. NO. 1334 A-I, PART

4) WITH GENESEE STREET (S.H. NO. 1212, PART 1);

THENCE S-70°-21'-08"-W ALONG THE CENTERLINE OF GENESEE STREET, A DISTANCE OF 243.11 FEET TO A POINT;

THENCE N-00°-02'-26"-E AND PARALLEL WITH THE CENTERLINE OF TRANSIT ROAD A DISTANCE OF 53.10 FEET TO THE **PRINCIPAL POINT OF BEGINNING**, BEING THE INTERSECTION OF THE EAST LINE OF LIBER 9548, PAGE 241 WITH THE NORTH LINE OF MAP 77, PARCEL 78, S.H. NO. 1212;

FROM THE **PRINCIPAL POINT OF BEGINNING**:

COURSE 1: THENCE N-00°-02'-26"-E, A DISTANCE OF 202.09 FEET TO THE POINT AT THE SOUTH LINE OF PERMANENT EASEMENT TO THE NEW YORK STATE DEPARTMENT OF PUBLIC WORKS AS SHOWN ON A MAP 141, PARCEL 153, TRANSIT ROAD, PART 4, S.H. 1334 A-I AND RECORDED IN LIBER 6320, PAGE 38;

COURSE 2: THENCE S-84°-34'-22"-E, ALONG THE SOUTH LINE OF PERMANENT EASEMENT TO THE NEW YORK STATE DEPARTMENT OF PUBLIC WORKS AS SHOWN ON A MAP 141, PARCEL 153, TRANSIT ROAD, PART 4, S.H. 1334 A-I AND RECORDED IN LIBER 6320, PAGE 38, A DISTANCE OF 31.41 FEET TO A POINT ;

COURSE 3: THENCE N-00°-02'-26"-E, A DISTANCE OF 35.71 FEET TO A POINT;

COURSE 4: THENCE S-89°-57'-34"-E, A DISTANCE OF 112.62 FEET TO A POINT;

COURSE 5: THENCE S-00°-02'-26"-W, 46.33 FEET TO A POINT;

COURSE 6: THENCE S-84°-34'-22"-E, 15.07 FEET TO THE POINT AT WESTERLY LINE OF TRANSIT ROAD (WIDTH VARIES);

COURSE 7: THENCE S-00°-02'-26"-W, ALONG A WESTERLY RIGHT OF WAY OF TRANSIT ROAD 100.28 FEET TO A POINT;

COURSE 8: THENCE WESTERLY S-20°-18'-28"-W, 36.82 FEET TO THE POINT AT THE NORTHERLY LINE OF GENESEE STREET (WIDTH VARIES);

COURSE 9: THENCE S-70°-21'-08"-W, ALONG THE NORTHERLY LINE OF GENESEE STREET (WIDTH VARIES) 212.92 FEET TO THE **PRINCIPAL POINT OF BEGINNING**.

CONTAINING 31041.65 SQ.FT. OR 0.71 MORE OR LESS ACRES.

LEGAL DESCRIPTION FOR PARCEL "B"

ALL THAT TRACT OR PARCEL OF LAND, SITUATE IN THE TOWN OF CHEEKTOWAGA, COUNTY OF ERIE AND STATE OF NEW YORK, AND BEING KNOWN AS PART OF LOT NUMBER 75, TOWNSHIP 11, RANGE 7 OF THE HOLLAND LAND COMPANY'S SURVEY, AND DESCRIBED AS FOLLOWS:

COMMENCING AT THE CENTERLINE INTERSECTION OF TRANSIT ROAD (S.H. NO. 1334 A-1, PART 4) WITH GENESEE STREET (S.H. NO. 1212, PART 1);

THENCE S-70°-21'-08"-W ALONG THE CENTERLINE OF GENESEE STREET, A DISTANCE OF 300.81 FEET TO A POINT;

THENCE N-00°-02'-26"-E AND PARALLEL WITH THE CENTERLINE OF TRANSIT ROAD A DISTANCE OF 53.10 FEET TO THE **PRINCIPAL POINT OF BEGINNING**, BEING THE INTERSECTION OF THE EAST LINE OF LIBER 9548, PAGE 241 WITH THE NORTH LINE OF MAP 77, PARCEL 78, S.H. NO. 1212;

FROM THE **PRINCIPAL POINT OF BEGINNING**:

COURSE 1: THENCE N-00°-02'-26"-E, ALONG THE AGREED PROPERTY LINE BETWEEN PHILOS PARTNERS INC. AND 81 & 3 OF FLORIDA, INC., A DISTANCE OF 226.66 FEET TO THE SOUTH LINE OF A PERMANENT EASEMENT TO THE NEW YORK STATE DEPARTMENT OF PUBLIC WORKS AS SHOWN ON A MAP 141, PARCEL 153, TRANSIT ROAD, PART 4, S.H. NO. 1334 A-1 AND RECORDED IN LIBER 6320 PAGE 38;

COURSE 2: THENCE S-84°-34'-22"-E, A DISTANCE OF 85.98 FEET TO A POINT;

COURSE 3: THENCE N-00°-02'-26"-E, 35.71 FEET TO A POINT;

COURSE 4: THENCE S-89°-57'-34"-E, A DISTANCE OF 112.62 FEET TO A POINT ON THE WEST LINE OF TRANSIT ROAD (WIDTH VARIES);

COURSE 5: THENCE S-00°-02'-26"-W, ALONG THE WEST LINE OF TRANSIT ROAD, A DISTANCE OF 46.33 FEET TO THE POINT ;

COURSE 6: THENCE S-84°-34'-22"-E, 15.07 FEET TO A POINT;

COURSE 7: THENCE S-00°-02'-26"-W, 100.28 FEET TO A POINT;

COURSE 8: THENCE S-20°-18'-28"-W, 36.82 FEET TO A POINT;

COURSE 9: THENCE S-70°-21'-08"-W, 212.92 FEET TO THE **PRINCIPAL POINT OF BEGINNING**;

CONTAINING 42688.8 SQ.F. OR 0.98 MORE OR LESS ACRES.

LAND TO BE CONVEYED TO STARBUCKS (PARCEL B-1)

ALL THAT TRACT OR PARCEL OF LAND, SITUATE IN THE TOWN OF CHEEKTOWAGA, COUNTY OF ERIE AND STATE OF NEW YORK, AND BEING KNOWN AS PART OF LOT NUMBER 75, TOWNSHIP 11, RANGE 7 OF THE HOLLAND LAND COMPANY'S SURVEY, AND DESCRIBED AS FOLLOWS:

COMMENCING AT THE CENTERLINE INTERSECTION OF TRANSIT ROAD (S.H. NO. 1334 A-I, PART

4) WITH GENESEE STREET (S.H. NO. 1212, PART 1);

THENCE S-70°-21'-08"-W ALONG THE CENTERLINE OF GENESEE STREET, A DISTANCE OF

243.11 FEET TO A POINT;
 THENCE N-00°-02'-26"-E AND PARALLEL WITH THE CENTERLINE OF TRANSIT ROAD A
 DISTANCE OF 53.10 FEET TO THE **PRINCIPAL POINT OF BEGINNING**, BEING THE
 INTERSECTION OF THE EAST LINE OF LIBER 9548, PAGE 241 WITH THE NORTH LINE OF
 MAP 77, PARCEL 78, S.H. NO. 1212;
 FROM THE **PRINCIPAL POINT OF BEGINNING**:

COURSE 1: THENCE N-00°-02'-26"-E, A DISTANCE OF 202.09 FEET TO THE POINT AT THE
 SOUTH LINE OF PERMANENT EASEMENT TO THE NEW YORK STATE DEPARTMENT OF
 PUBLIC WORKS AS SHOWN ON A MAP 141, PARCEL 153, TRANSIT ROAD, PART 4, S.H.
 1334 A-I AND RECORDED IN LIBER 6320, PAGE 38;

COURSE 2: THENCE S-84°-34'-22"-E, ALONG THE SOUTH LINE OF PERMANENT
 EASEMENT TO THE NEW YORK STATE DEPARTMENT OF PUBLIC WORKS AS SHOWN ON A
 MAP 141, PARCEL 153, TRANSIT ROAD, PART 4, S.H. 1334 A-I AND RECORDED IN LIBER
 6320, PAGE 38, A DISTANCE OF 31.41 FEET TO A POINT ;

COURSE 3: THENCE N-00°-02'-26"-E, A DISTANCE OF 35.71 FEET TO A POINT;

COURSE 4: THENCE S-89°-57'-34"-E, A DISTANCE OF 112.62 FEET TO A POINT;

COURSE 5: THENCE S-00°-02'-26"-W, 46.33 FEET TO A POINT;

COURSE 6: THENCE S-84°-34'-22"-E, 15.07 FEET TO THE POINT AT WESTERLY LINE OF
 TRANSIT ROAD (WIDTH VARIES);

COURSE 7: THENCE S-00°-02'-26"-W, ALONG A WESTERLY RIGHT OF WAY OF TRANSIT
 ROAD 100.28 FEET TO A POINT;

COURSE 8: THENCE WESTERLY S-20°-18'-28"-W, 36.82 FEET TO THE POINT AT THE
 NORTHERLY LINE OF GENESEE STREET (WIDTH VARIES);

COURSE 9: THENCE S-70°-21'-08"-W, ALONG THE NORTHERLY LINE OF GENESEE STREET
 (WIDTH VARIES) 212.92 FEET TO THE **PRINCIPAL POINT OF BEGINNING**.

CONTAINING 31041.65 SQ.FT. OR 0.71 MORE OR LESS ACRES.

PARCEL B-2

ALL THAT TRACT OR PARCEL OF LAND, SITUATE IN THE TOWN OF CHEEKTOWAGA,
 COUNTY OF ERIE AND STATE OF NEW YORK, AND BEING KNOWN AS PART OF LOT
 NUMBER 75,

TOWNSHIP 11, RANGE 7 OF THE HOLLAND LAND COMPANY'S SURVEY, AND DESCRIBED
 AS FOLLOWS:

COMMENCING AT THE CENTERLINE INTERSECTION OF TRANSIT ROAD (S.H. NO. 1334 A-I,
 PART

4) WITH GENESEE STREET (S.H. NO. 1212, PART 1);

THENCE S-70°-21'-08"-W ALONG THE CENTERLINE OF GENESEE STREET, A DISTANCE OF
 300.81 FEET TO A POINT;

THENCE N-00°-02'-26"-E AND PARALLEL WITH THE CENTERLINE OF TRANSIT ROAD A
 DISTANCE OF 53.10 FEET TO THE **PRINCIPAL POINT OF BEGINNING**, BEING THE
 INTERSECTION OF THE EAST LINE OF LIBER 9548, PAGE 241 WITH THE NORTH LINE OF
 MAP 77, PARCEL 78, S.H. NO. 1212;

FROM THE **PRINCIPAL POINT OF BEGINNING**:

COURSE 1: THENCE N-00°-02'-26"-E, ALONG THE AGREED PROPERTY LINE BETWEEN PHILOS PARTNERS, INC. AND 81 & 3 OF FLORIDA, INC., A DISTANCE OF 226.66 FEET TO THE POINT AT THE SOUTH LINE OF PERMANENT EASEMENT TO THE NEW YORK STATE DEPARTMENT OF PUBLIC WORKS AS SHOWN ON A MAP 141, PARCEL 153, TRANSIT ROAD, PART 4, S.H. 1334 A-I AND RECORDED IN LIBER 6320, PAGE 38;

COURSE 2: THENCE S-84°-34'-22"-W, ALONG THE SOUTH LINE OF PERMANENT EASEMENT TO THE NEW YORK STATE DEPARTMENT OF PUBLIC WORKS AS SHOWN ON A MAP 141, PARCEL 153, TRANSIT ROAD, PART 4, S.H. 1334 A-I AND RECORDED IN LIBER 6320, PAGE 38, A DISTANCE OF 54.57 FEET ;

COURSE 3: THENCE S-00°-02'-26"-W, A DISTANCE OF 202.09 FEET TO THE POINT ON THE NORTH LINE OF GENESEE STREET;

COURSE 4: THENCE S-70°-21'-08"-W, ALONG THE NORTH LINE OF GENESEE STREET, A DISTANCE OF 57.70 FEET TO THE **PRINCIPAL POINT OF BEGINNING**;

CONTAINING 11647.15 SQ.FT. OR 0.27 MORE OR LESS ACRES.

DRAINAGE AND INGRESS/EGRESS EASEMENT (PARCEL B-2)

ALL THAT TRACT OR PARCEL OF LAND, SITUATE IN THE TOWN OF CHEEKTOWAGA, COUNTY OF ERIE AND STATE OF NEW YORK, AND BEING KNOWN AS PART OF LOT NUMBER 75,

TOWNSHIP 11, RANGE 7 OF THE HOLLAND LAND COMPANY'S SURVEY, AND DESCRIBED AS FOLLOWS:

COMMENCING AT THE CENTERLINE INTERSECTION OF TRANSIT ROAD (S.H. NO. 1334 A-I, PART

4) WITH GENESEE STREET (S.H. NO. 1212, PART 1);

THENCE S-70°-21'-08"-W ALONG THE CENTERLINE OF GENESEE STREET, A DISTANCE OF 300.81 FEET TO A POINT;

THENCE N-00°-02'-26"-E AND PARALLEL WITH THE CENTERLINE OF TRANSIT ROAD A DISTANCE OF 53.10 FEET TO ATHE POINT AT NORTHERLY LINE OF GENESEE STREET;

THENCE S-00°-02'-26"-W, NORTHERLY, ALONG THE AGREED PROPERTY LINE BETWEEN PHILOS PARTNERS, INC. AND 81 & 3 OF FLORIDA, INC., A DISTANCE OF 199.83 FEET TO TO THE **PRINCIPAL POINT OF BEGINNING**;

FROM THE **PRINCIPAL POINT OF BEGINNING**:

COURSE 1: THENCE N-00°-02'-26"-E, ALONG THE AGREED PROPERTY LINE BETWEEN PHILOS PARTNERS, INC. AND 81 & 3 OF FLORIDA, INC., A DISTANCE OF 26.83 FEET TO THE POINT AT THE SOUTH LINE OF PERMANENT EASEMENT TO THE NEW YORK STATE DEPARTMENT OF PUBLIC WORKS AS SHOWN ON A MAP 141, PARCEL 153, TRANSIT ROAD, PART 4, S.H. 1334 A-I AND RECORDED IN LIBER 6320, PAGE 38;

COURSE 2: THENCE S-84°-34'-22"-E, ALONG THE SOUTH LINE OF PERMANENT EASEMENT TO THE NEW YORK STATE DEPARTMENT OF PUBLIC WORKS AS SHOWN ON A MAP 141, PARCEL 153, TRANSIT ROAD, PART 4, S.H. 1334 A-I AND RECORDED IN LIBER 6320, PAGE 38, A DISTANCE OF 54.57 FEET ;

COURSE 3: THENCE S-00°-02'-26"-W, A DISTANCE OF 21.56 FEET TO A POINT;

COURSE 4: THENCE N-89°-54 '-53"-W, A DISTANCE OF 54.33 FEET TO THE **PRINCIPAL POINT OF BEGINNING**;

Attachment: Legal Description 5100 Genesee Street_MS to CM (RES-2011-584 : Call for Public Hearing - 5100 Genesee Street)

CONTAINING 11647.15 SQ.FT. OR 0.03 MORE OR LESS ACRES.

DRAINAGE EASEMENT (PARCEL B-1)

ALL THAT TRACT OR PARCEL OF LAND, SITUATE IN THE TOWN OF CHEEKTOWAGA, COUNTY OF ERIE AND STATE OF NEW YORK, AND BEING KNOWN AS PART OF LOT NUMBER 75,

TOWNSHIP 11, RANGE 7 OF THE HOLLAND LAND COMPANY'S SURVEY, AND DESCRIBED AS FOLLOWS:

COMMENCING AT THE CENTERLINE OF TRANSIT ROAD (S.H. NO. 1334 A-I, PART 4) WITH GENESEE STREET (S.H. NO. 1212, PART 1);

THENCE S 70°-21'-08" W ALONG THE CENTERLINE OF GENESEE STREET, A DISTANCE OF 243.11 FEET TO A POINT;

THENCE N-00°-02'-26"-E AND PARALLEL WITH THE CENTERLINE OF TRANSIT ROAD A DISTANCE OF 53.10 FEET TO A POINT;

THENCE CONTINUING N-00°-02'-26"-E A DISTANCE OF 180.51 FEET TO THE **PRINCIPAL POINT OF BEGINNING**; FROM **PRINCIPAL POINT OF BEGINNING**:

COURSE 1: THENCE N-00°-02'-26"-E, A DISTANCE OF 21.56 FEET TO A POINT;

COURSE 2: THENCE S-84°-34'-22"-E, A DISTANCE OF 31.41 FEET TO A POINT;

COURSE 3: THENCE N-00°-02'-26"-E, A DISTANCE OF 35.71 FEET TO A POINT;

COURSE 4: THENCE S-89°-57'-34"-E, A DISTANCE OF 112.62 FEET TO THE POINT ON THE WEST LINE OF TRANSIT ROAD AS DESCRIBED IN LIBER 9378, PAGE 444 AND SHOWN ON MAP NO. 174, PARCEL NO'S 193 & 194 O.F.S.H. NO. 1334 A-L, PART 4; ;

COURSE 5: THENCE S-00°-02'-26"-W, ALONG THE SAID WEST LINE OF TRANSIT ROAD, A DISTANCE OF 46.33 FEET TO A POINT;

COURSE 6: THENCE S-84°-34'-22"-E, A DISTANCE OF 15.07 FEET TO A POINT;

COURSE 7: THENCE S-00°-02'-26"-W, ALONG SAID WEST LINE OF TRANSIT ROAD, A DISTANCE OF 19.28 FEET TO A POINT;

COURSE 8: THENCE N-84°-12'-45"-W, A DISTANCE OF 127.27 FEET TO A POINT;

COURSE 9: THENCE N-89°-54'-33"-W, A DISTANCE OF 32.26 FEET TO THE **PRINCIPAL POINT OF BEGINNING**.

CONTAINING 0.176 MORE OR LESS ACRES.

INGRESS/EGRESS EASEMENT (PARCEL B-1)

ALL THAT TRACT OR PARCEL OF LAND, SITUATE IN THE TOWN OF CHEEKTOWAGA, COUNTY OF ERIE AND STATE OF NEW YORK, AND BEING KNOWN AS PART OF LOT NUMBER 75,

TOWNSHIP 11, RANGE 7 OF THE HOLLAND LAND COMPANY'S SURVEY, AND DESCRIBED AS FOLLOWS:

COMMENCING AT THE CENTERLINE OF TRANSIT ROAD (S.H. NO. 1334 A-I, PART 4) WITH GENESEE STREET (S.H. NO. 1212, PART 1);

THENCE S 70°-21'-08" W ALONG THE CENTERLINE OF GENESEE STREET, A DISTANCE OF 243.11 FEET TO A POINT;

THENCE N-00°-02'-26"-E AND PARALLEL WITH THE CENTERLINE OF TRANSIT ROAD A DISTANCE OF 53.10 FEET TO A POINT ;

THENCE CONTINUING N-00°-02'-26"-E A DISTANCE OF 180.51 FEET TO THE **PRINCIPAL POINT OF BEGINNING**;

FROM THE **PRINCIPAL POINT OF BEGINNING**:

COURSE 1: THENCE N-00°-02'-26"-E, A DISTANCE OF 21.56 FEET TO A POINT;

COURSE 2: THENCE S-84°-34'-22"-E, A DISTANCE OF 31.41 FEET TO A POINT;

COURSE 3: THENCE N-00°-02'-26"-E, A DISTANCE OF 5.94 FEET TO A POINT;

COURSE 4: THENCE S-84°-12'-45"-E, A DISTANCE OF 108.90 FEET TO THE POINT ON THE WEST LINE OF TRANSIT ROAD AS DESCRIBED IN LIBER 9378, PAGE 444 AND SHOWN ON MAP NO. 174, PARCEL NO'S 193 & 194 O.F.S.H. NO. 1334 A-L, PART 4; ;

COURSE 5: THENCE S-00°-02'-26"-W, ALONG THE SAID WEST LINE OF TRANSIT ROAD, A DISTANCE OF 13.73 FEET TO A POINT;

COURSE 6: THENCE S-84°-34'-22"-E, A DISTANCE OF 15.07 FEET TO A POINT;

COURSE 7: THENCE S-00°-02'-26"-W, ALONG SAID WEST LINE OF TRANSIT ROAD, A DISTANCE OF 19.28 FEET TO A POINT;

COURSE 8: THENCE N-84°-12'-45"-W, A DISTANCE OF 127.27 FEET TO A POINT

COURSE 9: THENCE N-89°-54'-33"-W, A DISTANCE OF 32.26 FEET TO THE **PRINCIPAL POINT OF BEGINNING**.

CONTAINING 0.095 MORE OR LESS ACRES.

REFERENCES:

- 1 L. 6320, P. 38 MAP 141, PARCEL 153 PERM. EASEMENT (1957) REPUTED OWNER - BEHRINGER ESTATE
- 2 L. 6290, P. 563 MAP 140, PARCEL 152 PERM. EASEMENT (1957) REPUTED OWNER - S. SCIANDRA
- 3 L. 6195, P. 211 MAP 67, PARCEL 74 FEE-NYSDPW (1956)
REPUTED OWNER - DI BELLO & SCRUGGS
- 4 L. 8189, P. 7 MAP 78, PARCEL 79 FEE-NYSDOT (1991)
REPUTED OWNER - NATIONAL FUEL GAS
- 5 L. 9992, P. 416 MAP 77, PARCEL 78 FEE-NYSDOT (1991)
REPUTED OWNER - QUAL-ECON LEASE CO., INC.
- 6 L. 6320, P. 45,46 MAP 138, PARCEL 150 FEE-NYSDPW (1957)
REPUTED OWNER - BEHRINGER ESTATE
- 7 L. 9378, P. 444 MAP 174, PARCEL 193 & 194 FEE-NYSDOT (1992) REPUTED OWNER - MDM
PETROLEUM
- 8 L. 8891, P. 582 - CONVEYS TO JOHN W. HENNESSEY (1980)
L. 10969, P. 2148 - CONVEYS TO H. LORN ANDERSON (2000)
L. 6438, P. 423 - CONVEYS TO KERMIT E. SCRUGGS (1959)
- 9 L. 11002, P. 9881 - CONVEYS TO 81&3 OF FLORIDA INC. (2002)
- 10 L. 7258, P. 447 - CONVEYS TO THE DAVEY TREE EXPERT COMPANY INC. (1966) SBL# 093.01-1-5
- 11 SURVEYS : GRAF LAND SURVEYORS JOB # 52121 (4-18-88)
SODERHOLM ENGINEERING JOB# 86929 (4-24-86)
ROBERT B. BAIRD DWG# 922187-01 (12-18-92)
- 12 D.O.T. CONSTRUCTION DRAWINGS - F.A.PROJECT NH-24(114)
CONTRACT# D254088
13. SITE IMPROVEMENT PLAN (C1.1) & EXISTING SITE CONDITION (C1.0) DATED 02-02/2006 PREPARED BY
GENESEE ENGINEERING, PLANNING, SURVEING, P.C.
14. ABSTRACT OF TITLE No:T132256 PREPARED BY STEWART TITLE INSURANCE COMPANY

Site Notes

- The Contractor shall coordinate with utility companies prior to beginning work.
- Underground utilities are shown according to the best information made available to us and in approximate location only. Location is subject to verification prior to construction.
- CAUTION:** Underground utilities including, but not limited to electric, telephone, gas water sanitary sewer and storm sewer are reportedly in the vicinity of this project. Every precaution should be taken during excavation. New York state law requires notification of each utility company two full working days prior to commencement of work.
- Coordinate the location of all utilities with foundations, subsurface utilities locations, locations of existing utility valves and authorities having jurisdiction over each utility.
- Contractor shall use extreme caution to protect all existing trees and vegetation, and all areas outside the project limits.
- Any damage to the existing utilities, buildings, paving, curb, walls and vegetation (not so designated for removal on these plans) shall be repaired to the previous condition or replaced in kind by the contractor at his own expense.
- Blend all new grades to existing grades. Slope finished grade for positive drainage away from the building.
- Notify and obtain all required permits from each utility service required. Coordinate required inspections, testing and certifications by authority having jurisdiction over each utility service. The contractor is responsible for all filing, testing, inspections and associated fees with each utility.
- The Contractor shall comply with the Town Of Elma standard drawings and specifications.
- The Contractor shall immediately notify the project engineer and the Town Of Elma Engineering Department of any hazardous substance encountered during the construction of the work. He shall, at his expense, conform to all laws, rules, regulations and directions, as promulgated by the United States Department of Labor, Occupational Safety and Health Administration, the New York State Department of Health and any such local rules, ordinances and laws when encountering or working with any such hazards.
- Notify the Erie County Water Authority at least 48 hours in advance of the start of construction. All existing valves are to be operated by the Erie County Water Authority.
- The contractor shall expose existing utilities ahead of the pipe-laying operation, so that, if minor adjustments must be made in elevation and/or alignment due to the interference from these utilities, said changes can be made in advance of the work.
- Unsuitable materials such as frozen organic and/or vegetable material, debris, trees, lumber, large stones or clogs (6.0' or larger), muck, peat, organic silt will not be acceptable fill and certain man-made deposits of industrial waste, sludge or landfill are also to be determined as unsuitable hazardous material.
- The compaction of all materials will occur at 6' increments, unless otherwise noted.
- Should a fluid condition be encountered at the trench bottom, the Contractor is to install additional stone cradle as ordered by the Engineer.
- All pipe crossing under paved areas are to be backfilled to subgrade with compacted select material to five (5) feet outside the pavement edges.
- The Contractor shall retain the services of a qualified tree expert to remove where necessary, branches which interfere with the construction operation, or repair trees having suffered damage by construction activities. The cost involved in the above is to be included in the various items of the contract.
- Cast in place concrete shall conform to the requirements of NYS.D.O.T. standard specification section 501 for portland cement concrete.
- All pipe storm sewer piping to be high density polyethylene pipe (HDPE) with annular corrugations smooth bore N= 0.012 (Or Less) storm sewer or equal.
- Receivers shall be constructed in accordance with NYS.D.O.T. standard specification 604.
- Construction is in accordance with Town Of Elma Construction Specifications where applicable and/or subject to the latest decisions by the Town Of Elma.

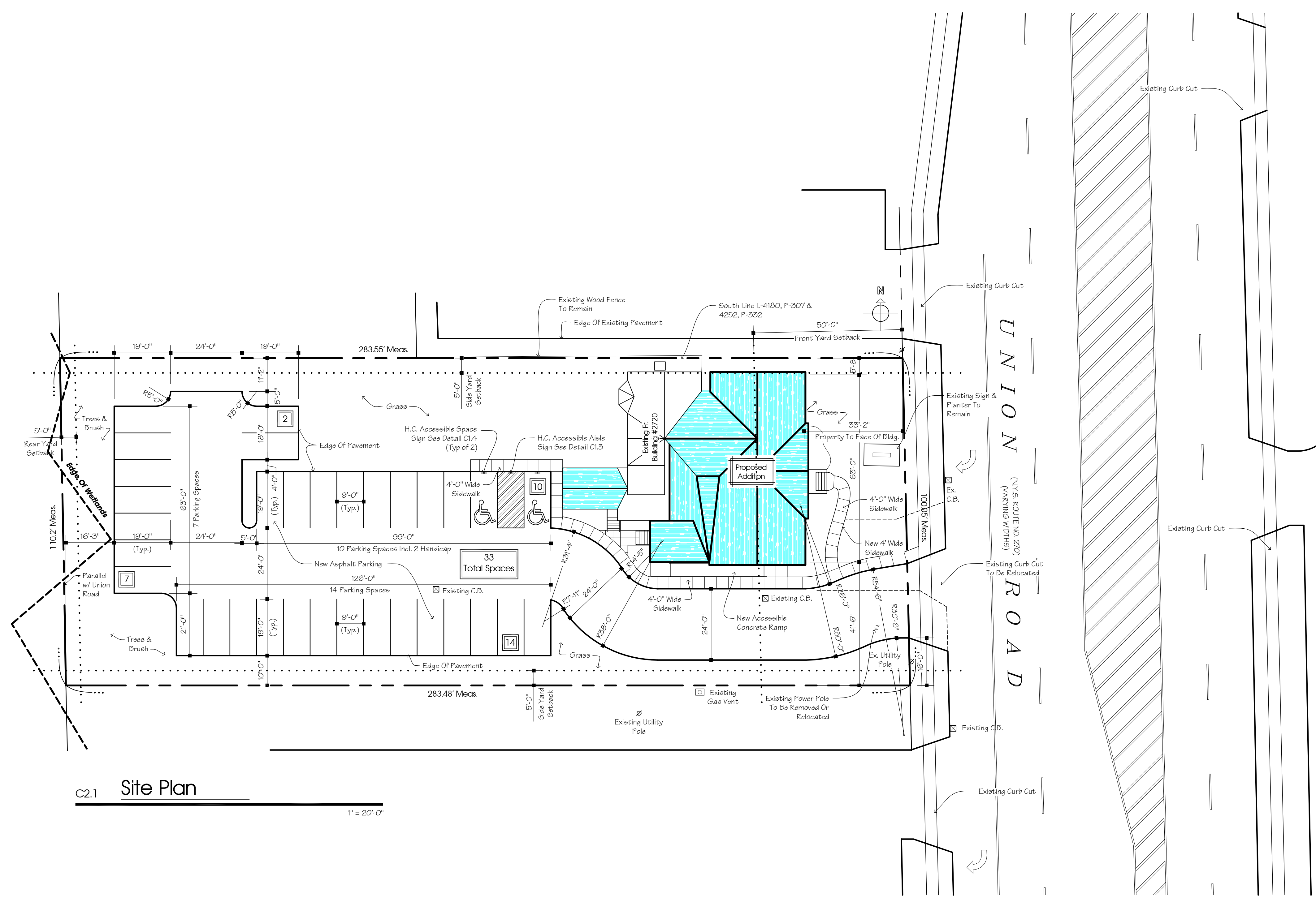

Yard	Parking		Structure	
	Allowable	Actual	Allowable	Actual
Front	10'-0"	113'-0"	5'-0"	31'-2"
Side	10'-0"	10'-0"/11'-2"	5'-0"	5'-8"/41'-6"
Rear	10'-0"	16'-3"	5'-0"	168'-0"

Parking Areas (1) Spaces Per 200 Sqft. Gross = 19 Spaces Req.
Spaces Provided = 33 Spaces

Required Accessible Parking Spaces Total Spaces 33, requires 2 HC spaces

Pedestrian walks have been provided from parking areas to the building to ensure pedestrian safety

48.04% of the total ground area is or will be landscaped with deciduous and conifer trees, deciduous and conifer shrubs, ground cover and grass.

Land Use		
Total Area	31,275 s.f.	100.0%
Buildings	3,718 s.f.	11.89%
Sidewalk	1,052 s.f.	3.36%
Paved Areas	13,086 s.f.	41.84%
Green Space	13,419 s.f.	42.91%

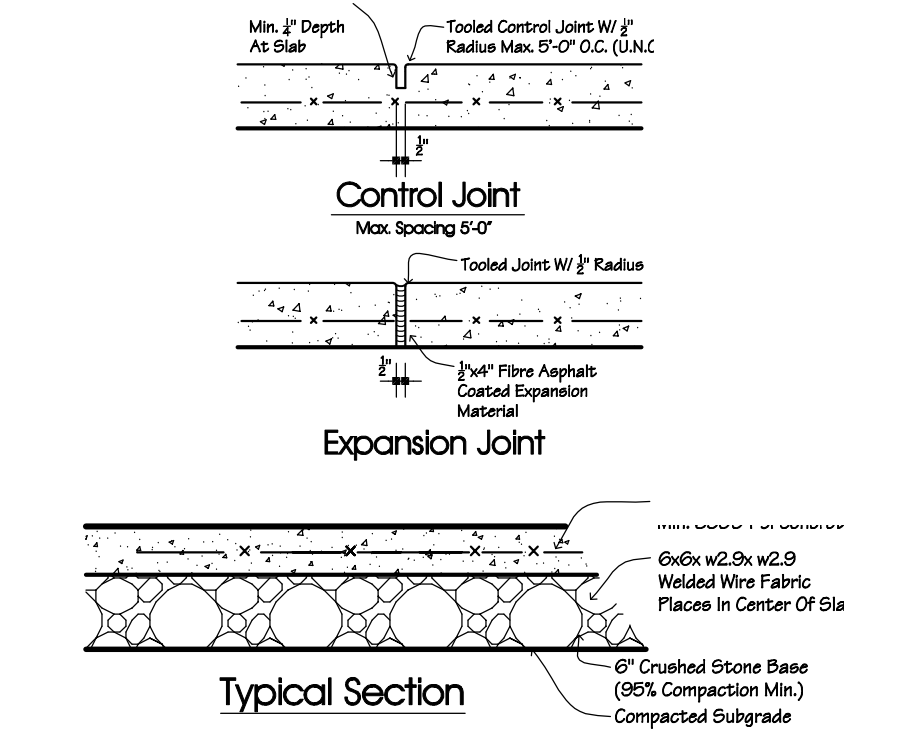
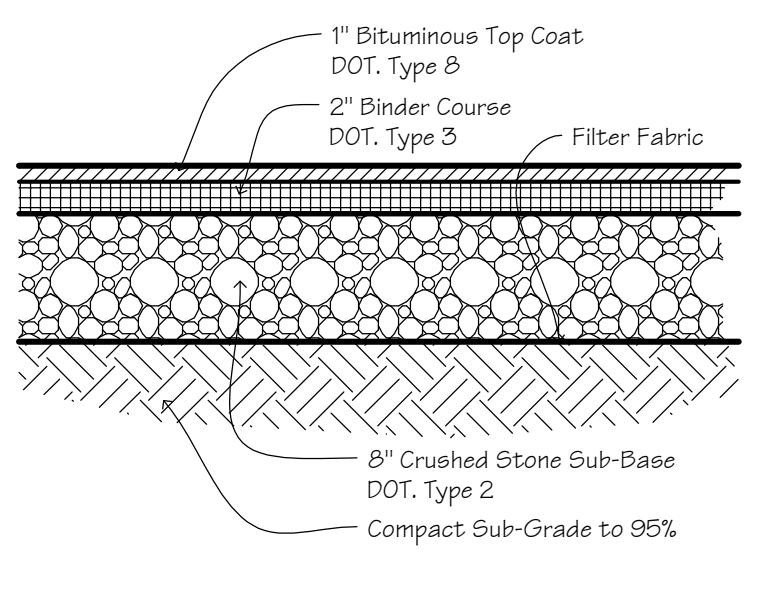
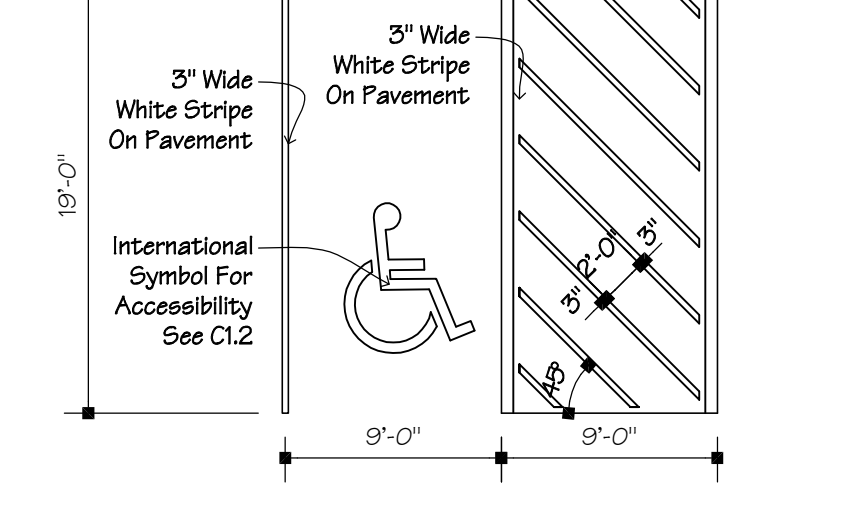
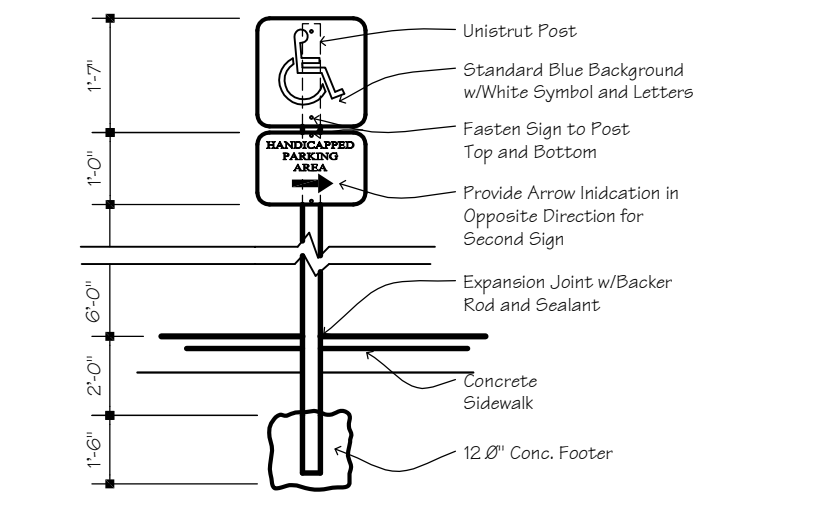
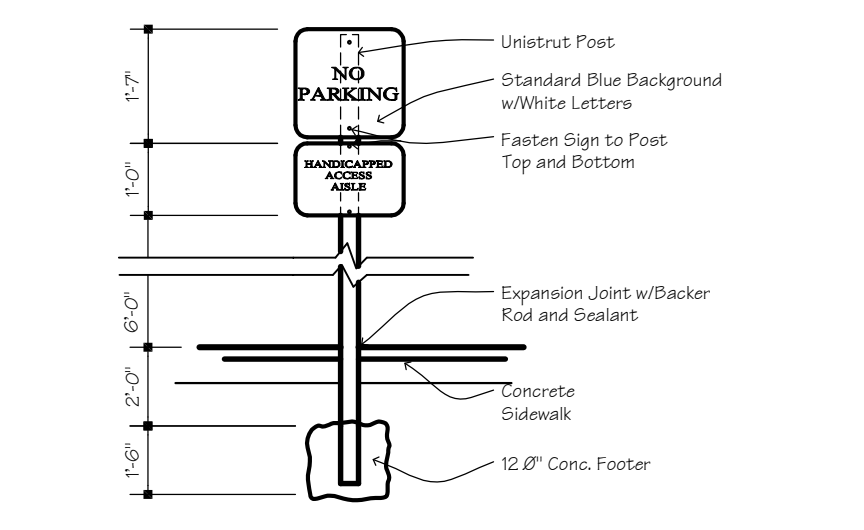
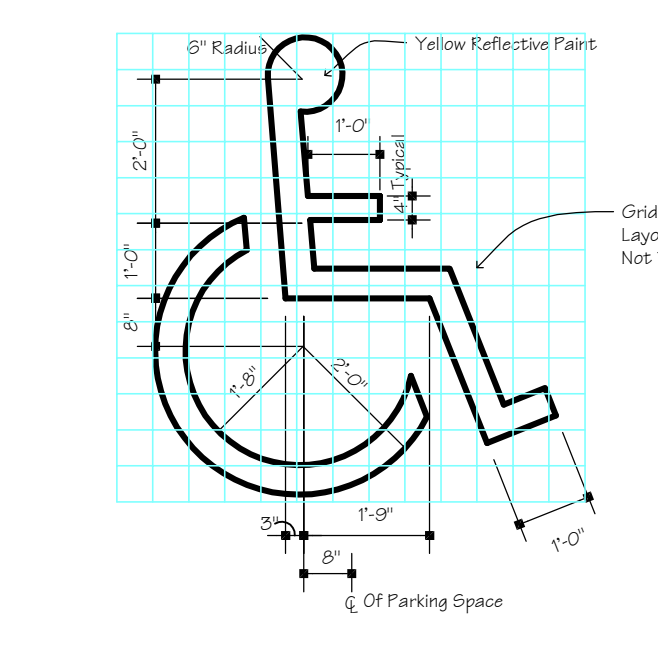

3284 Walden Avenue
 Depew, New York 14043
 (716) 651-0381 Fax 651-0382

Job Number:
11-202

Proposed Addition For:



2720 Union Rd.
 Cheektowaga, NY

Copyright Deansutton Architects © 2011

No.	Description	Date	By

WARNING:
 It is a violation of Article 147, Section 7303 of the New York State Education Law for any person to alter an item, in any way, on this document, unless under the direction of a licensed Architect.

Title:
Site Plan

Drawn By:
 A. Brose
 Date:
 9/16/11
 Checked:
 M. Dean
 Scale:
 1"=20'-0"

Sheet No.:
C-2

CHEEKTOWAGA PLANNING BOARD

MINUTES FROM MEETING OF SEPTEMBER 8TH, 2011

REGULAR MEETING WAS CALLED TO ORDER OF THE PLANNING BOARD OF THE TOWN OF CHEEKTOWAGA, ERIE COUNTY, NEW YORK AT THE TOWN HALL COUNCIL CHAMBERS IN SAID TOWN OF CHEEKTOWAGA SEPTEMBER 8TH, 2011 AT 7:00 PM

PLEDGE LED BY MRS. J. ADAMS

ATTENDANCE: S. KUCEWICZ ABSENT

MOTION MADE BY MRS. ADAMS AND SECONDED BY MRS. CASACCI TO DISPENSE WITH THE READING OF THE AUGUST MINUTES. ALL IN FAVOR

OLD BUSINESS:

**ITEM 1 5100 GENESEE ST.
 SITE PLAN & REZONING REQUEST**

THIS PROPOSAL IS FOR SITE PLAN APPROVAL AND A REZONING FROM MS TO C RETAIL. THE PLANNING BOARD VOTED UNANIMOUSLY TO RECOMMEND APPROVAL OF THE RE ZONING SO THAT A PUBLIC HEARING CAN BE SCHEDULED. PLANNING BOARD RESERVED DECISION ON THE SITE PLAN AS THE APPLICANT HAS TO RETURN FOR ARCHITECTURAL AND LANDSCAPE APPROVAL.

**ITEM 2 2720 UNION ROAD
 DR. LEGARRETTA/DEAN SUTTON ARCHITECTS
 SITE PLAN**

THIS PROPOSED PROJECT IS A 2500 SF ADDITION TO THE EXISTING OPTICIANS OFFICE. PARKING HAS BEEN MOVED TO REAR AND THE AMOUNT OF SPACES HAS INCREASED. SIDING WILL BE REPLACED AND APPLICANT HAS MET ALL SET BACK REQUIREMENTS.

A MOTION WAS MADE BY MS. MEYERS AND SECONDED BY MRS. CASACCI TO RECOMMEND APPROVAL OF SITE PLAN AND TO APPROVE THE LANDSCAPING AND ARCHITECTURAL PLAN. ALL IN FAVOR.

A MOTION WAS MADE AND SECONDED TO ADJOURN. ALL IN FAVOR.

RESPECTFULLY SUBMITTED,

JOAN C. MEYERS, SECRETARY
CHEEKTOWAGA PLANNING BOARD

CHEEKTOWAGA PLANNING BOARD

MINUTES FROM MEETING OF OCTOBER 13TH, 2011

REGULAR MEETING WAS CALLED TO ORDER OF THE PLANNING BOARD OF THE TOWN OF CHEEKTOWAGA, ERIE COUNTY, NEW YORK AT THE TOWN HALL COUNCIL CHAMBERS IN SAID TOWN OF CHEEKTOWAGA OCTOBER 13TH, 2011 AT 7:00 PM

PLEDGE LED BY MR. KUCEWICZ

ATTENDANCE: ALL PRESENT

MOTION MADE BY Mr. KUCEWICZ AND SECONDED BY MRS. CASACCI TO DISPENSE WITH THE READING OF THE SEPTEMBER MINUTES. ALL IN FAVOR

OLD BUSINESS:

**ITEM 1 5100 GENESEE ST.
 SITE PLAN & REZONING REQUEST**

NO ONE IN ATTENDANCE / ITEM TABLED

NEW BUSINESS

**ITEM 1 4243 GENESEE ST.
 SITE PLAN**

APPLICANT IN ATTENDANCE REQUESTING SITE PLAN APPROVAL. THIS IS THE LAST OF THE HOTELS PROPOSED FOR GENESEE ST. WHICH WILL BE LOCATED ON THE SO. END OF THE PARCEL. THE AREA IS A PARKING LOT WHICH WILL BE REDEVELOPED FOR A 4 STORY, 119 ROOM HOTEL. THIS WILL INCLUDE NEW DRAINAGE, NEW SITE LIGHTING AND MORE LANDSCAPING.

A MOTION WAS MADE BY MR. KUCEWICZ AND SECONDED BY MRS. ADAMS TO RECOMMEND APPROVAL OF THE SITE PLAN, ARCHITECTURAL DESIGN AND LANDSCAPING CONTINGENT ON DOT, NFTA AND THE ZBA. ALL IN FAVOR.

**ITEM 2 866 AERO DRIVE
 THE KROG CORP.**

THIS PROPOSAL IS FOR A 28,631 WAREHOUSE / OFFICE.
THIS ITEM WAS TABLED FOR FURTHER REVIEW.

**ITEM 3 105 AFFINITY LANE
 SITE PLAN**

THIS PROJECT IS THE DEVELOPMENT AND CONSTRUCTION OF A 4500 SF CONCESSION BLDG. ADJACENT TO THE EXISTING COMMUNITY BUILDING. THE PROJECT INCLUDES A PATIO FOR INSIDE AND OUTSIDE DINING. DRAINAGE IS IN PLACE AND PARKING WILL NOT CHANGE. A MOTION WAS MADE AND SECONDED TO RECOMMEND APPROVAL OF THE SITE PLAN AND TO APPROVE THE LANDSCAPING AND ARCHITECTURAL DESIGN. ALL IN FAVOR.

**ITEM 4 51 ANDERSON ROAD
 REZONING REQUEST**

APPLICANT IS REQUESTING A REZONING FROM M2 TO MS FOR THE CONVERSION OF A WAREHOUSE TO PROPOSED TRUCK AND AUTOMOTIVE REPAIR FACILITY WITH TOWING SERVICES.

THE PLANNING BOARD VOTED UNANIMOUSLY TO RECOMMEND APPROVAL OF THE REZONING.

**ITEM 5 125 GARDENVILLE PKWY.
 SITE PLAN**

THIS PROPOSED PROJECT IS FOR THE EXPANSION OF EXISTING OFFICE PARKING LOT ON THE EXISTING PROPERTY TO HAVE MORE PARKING SPACES AND MORE HANDICAP PARKING. A MOTION WAS MADE BY MRS. CASACCI AND SECONDED BY MRS. ADAMS TO RECOMMEND APPROVAL OF THE SITE PLAN. ALL IN FAVOR.

**ITEM 6 2501 BROADWAY
 ALLIED FROZEN STORAGE, INC.**

APPLICANT IS REQUESTING APPROVAL FOR A REVISION TO A PREVIOUSLY APPROVED SITE PLAN. PLANNING BOARD DOES NOT AGREE WITH THE DEVELOPERS PROPOSED CHANGES TO REDUCE THE NUMBER OF TREES FROM THE ORIGINAL PLAN.

A MOTION WAS MADE BY MS. MEYERS AND SECONDED BY MRS. CASACCI TO RECOMMEND DENIAL. ALL IN FAVOR.

MEETING ADJOURNED.

RESPECTFULLY SUBMITTED,

**JOAN C. MEYERS, SECRETARY
CHEEKTOWAGA PLANNING BOARD**



Town of Cheektowaga

Regular Meeting

~ Minutes ~

3301 Broadway
Cheektowaga, NY 14227
<http://www.town.cheektowaga.ny.us>

Alice Magierski
716-686-3400

Monday, November, 21, 2011

6:45 PM

Council Chambers

I. Call to Order

6:45 PM Meeting called to order on November 21, 2011 at Council Chambers, 3301 Broadway St, Cheektowaga, NY.

Attendee Name	Organization	Title	Status	Arrived
Mary Holtz	Town of Cheektowaga	Supervisor	Present	
Patricia Jaworowicz	Town of Cheektowaga	Councilmember	Present	
Jeff Swiatek	Town of Cheektowaga	Councilmember	Present	
James Rogowski	Town of Cheektowaga	Councilmember	Present	
Richard Zydel	Town of Cheektowaga	Councilmember	Present	
Charles Markel	Town of Cheektowaga	Councilmember	Present	
Stanley Kaznowski	Town of Cheektowaga	Councilmember	Present	

2. Additional Attendees

Thomas Adamczak, Supervising Building and Plumbing Inspector
Brian Krause, Director of Finance and Administration
John Marriott, Planning Board Chairman
William Pugh, Town Engineer
Anthony Romano, Coordinator of Employee Relations
Kevin Schenk, Town Attorney

II. Public Comment Period

III. Public Hearings at 6:45 pm

1. Rezoning Request 5100 Genesee Street

This being the time and place advertised for a Public Hearing, the Supervisor directed the Town Clerk to present that such notice has been duly published and posted; upon the order of the Supervisor such proof was duly filed.

The Supervisor announced that the Town Board would hear all persons interested in the subject of the hearing. Comments were heard, after which the Supervisor declared the hearing closed, decision was reserved.

RESULT: CLOSED [UNANIMOUS]
MOVER: James Rogowski, Councilmember
SECONDER: Charles Markel, Councilmember
AYES: Holtz, Jaworowicz, Swiatek, Rogowski, Zydel, Markel, Kaznowski

2. Amend Vehicle & Traffic Ordinance

This being the time and place advertised for a Public Hearing, the Supervisor directed the Town Clerk to present that such notice has been duly published and posted; upon the order of the Supervisor such proof was duly filed.

The Supervisor announced that the Town Board would hear all persons interested in the subject of the hearing. Comments were heard, after which the Supervisor declared the hearing closed, decision was reserved.

RESULT: CLOSED [UNANIMOUS]
MOVER: James Rogowski, Councilmember
SECONDER: Charles Markel, Councilmember
AYES: Holtz, Jaworowicz, Swiatek, Rogowski, Zydel, Markel, Kaznowski

IV. Resolutions



1. RESOLUTION 2011-596

Transfer of Funds

Sponsored By: Supervisor Holtz, Councilmember Swiatek

BE IT RESOLVED, that the following transfer is hereby approved and made a part hereof;

GENERAL FUND

FROM:	100.5132.4431	Radio Repair	\$ 2,000.00
TO:	100.5132.4432	Building & Maintenance	\$ 2,000.00

SPECIAL DISTRICTS FUND

FROM:	255.8125.4217	Utilities	\$ 2,110.56
	990.1910.2681	Light Standard Damages	2,755.13
TO:	255.8125.4163	Gas, Oil & Grease	\$ 2,110.56
	990.5182.4432	Repairs & Maintenance	2,755.13

HIGHWAY FUND

FROM:	300.1910.2665	Sale of Equipment	\$ 3,167.20
	300.5110.4185	Barricades & Blocks	8,000.00
	300.5130.4087	Conferences & Seminars	2,000.00
	300.5110.4186	Topsoil	15,000.00
	300.5130.2407	Highway Equipment	30,000.00
	300.5140.4297	Tree Maintenance	3,000.00
	300.5148.4029	Services Other Gov't	3,500.00
TO:	300.5130.4462	Parts & Supplies	\$ 3,167.20
	300.5130.4462	Parts & Supplies	10,000.00
	300.5150.4162	Gasoline & Oil	15,000.00
	300.5140.4191	Misc. Expense	36,500.00

HUD NYS AHC FUNDING

FROM:	900.8600.4910	NYS AHC Revenues	\$100,000.00
TO:	900.8668.4008	Loans from Program	\$100,000.00

RESULT:	ADOPTED [UNANIMOUS]
MOVER:	Mary Holtz, Supervisor
SECONDER:	Jeff Swiatek, Councilmember
AYES:	Holtz, Jaworowicz, Swiatek, Rogowski, Zydel, Markel, Kaznowski



2. RESOLUTION 2011-597

Warrant

Sponsored By: Supervisor Holtz, Councilmember Swiatek

BE IT RESOLVED, that the following Vouchers & Warrants submitted to the Town of Cheektowaga prior to November 18, 2011 are hereby approved and made a part hereof;

GENERAL FUND	\$ 127,560.72
RISK RETENTION FUND	22,517.62
HUD HOUSING REHABILITATION FUND	9,826.00
SPECIAL DISTRICTS FUND	197,759.57
HIGHWAY FUND	15,112.08
CAPITAL FUND	411,468.35
TRUST & AGENCY FUND	17,359.62
HUD CDBG FUND	5,725.00
PART TOWN FUND	113.30
NYS AFFORDABLE HOUSING	35,035.00
	<u>\$ 842,477.26</u>

RESULT: **ADOPTED [UNANIMOUS]**

MOVER: Mary Holtz, Supervisor

SECONDER: Jeff Swiatek, Councilmember

AYES: Holtz, Jaworowicz, Swiatek, Rogowski, Zydel, Markel, Kaznowski



3. RESOLUTION 2011-598

Adopt Amendments to Vehicles and Traffic Ordinance

Sponsored By: Councilmember Zydel, Councilmember Markel

WHEREAS, this Town Board held a public hearing on November 21, 2011 to consider the advisability of adopting proposed amendments to Chapter 235 of the Code of the Town of Cheektowaga (Vehicle and Traffic), said hearing being held in accordance with Notice thereof which was duly published as required by law, at which hearing an opportunity to be heard was afforded all persons interested in the subject thereof,

NOW, THEREFORE, BE IT RESOLVED, as follows:

Section 1.

That this Town Board determines it is in the public interest to adopt the following amendments to Chapter 235 of the Code of the Town of Cheektowaga, County of Erie and State of New York, and said amendments are herewith adopted and enacted:

ARTICLE V. Schedules, Section 235-46, Schedule VII: Stop Intersections, shall be amended by adding thereto the following:

In accordance with the provisions of §235-18, the following described intersections and locations are designated stop intersections:

<u>Stop Sign on</u>	<u>Direction Traffic Stops</u>	<u>At Intersection of</u>
NORM BEALER WAY	South	Losson Road
MELCOURT DR WEST	North	Dawn Road

ARTICLE V. Schedules, Section 235-49, Schedule X: Parking Prohibited in Designated Locations, shall be amended by adding thereto the following:

In accordance with the provisions of §235-34, no person shall park a vehicle at any time upon any of the following described streets or parts of streets:

COLBY STREET - West side: from south curb line of William Street to north curb line of Parker Street

SOUTH COLBY STREET - West side: from south curb line of Parker Street to north curb line of Dingens Street

ARTICLE V. Schedules, Section 235-49, Schedule X: Parking Prohibited in Designated Locations, shall be amended by deleting therefrom the following:

In accordance with the provisions of §235-34, no person shall park a vehicle at any time upon any of the following described streets or parts of streets:

COLBY STREET - East side: from south curb line of William Street to north curb line of Parker Street

SOUTH COLBY STREET - East side: from south curb line of Parker Street to north curb line of Dingens Street

SOUTH COLBY STREET - West side: 50 feet north of north curb line of Dingens Street

Section 2. Time to Take Effect

These amendments shall take effect when properly posted within a reasonable time except those parts, if any, which are subject to approval under Section 1684 of the Vehicle and Traffic Law of the State of New York.

Any part or parts of these amendments which are subject to approval under Section 1684 of the Vehicle and Traffic Law of the State of New York shall take effect from and after the day on which approval in writing is received from the New York State Traffic Commission.

Section 3. Territorial Application

These amendments shall apply to all of the Town of Cheektowaga, Erie County, New York outside of the villages of Depew and Sloan.

Section 4. Publication

That these amendments to Chapter 235 (formerly Chapter 76) of the Code of the Town of Cheektowaga shall be entered into the minutes of the Town Board and shall be published in the CHEEKTOWAGA BEE, a newspaper published in this Town, and affidavits of such publication shall be filed with the Town Clerk and the Town Clerk shall likewise enter in the Ordinance Book a copy of said amendments specifying the date of adoption thereof.

RESULT:	ADOPTED [UNANIMOUS]
MOVER:	Richard Zydel, Councilmember
SECONDER:	Charles Markel, Councilmember
AYES:	Holtz, Jaworowicz, Swiatek, Rogowski, Zydel, Markel, Kaznowski



4. RESOLUTION 2011-599

Change Order No. 1 - O'Connell Electric Company

Sponsored By: Supervisor Holtz, Councilmember Swiatek

WHEREAS, by Town Board Resolution dated May 2, 2011 this Town Board awarded the contract for the Installation of Solar Power Systems on the Roofs of Various Town Buildings to O'Connell Electric Company, Inc., 830 Phillips Road, Victor, New York 14564 in the amount of \$937,496.00, AND

WHEREAS, in addition to the federal grant funding the Town received from the Department of Energy under the Energy Efficiency and Conservation Block Grant Program, the subject project is also deemed eligible for financial incentives for new grid-connected photovoltaic systems under the New York State Energy Research and Development Authority (NYSERDA) Solar PV Program Opportunity Notice (PON) 2112, and in accordance with the project contract documents, the NYSERDA incentive award paid directly to the eligible installer shall be deducted in its entirety from the Town's contract with O'Connell Electric, AND

WHEREAS, the Town Engineer and Nussbaumer & Clarke, Inc. have recommended approval of Change Order No. 1 for the Installation of Solar Power Systems on Various Town Buildings Project, which provides for the deduction of the NYSERDA incentive award amount for each of the four (4) respective buildings and also provides for Town Hall roof repair and roof decking replacement, fascia, gutter and electrical system modifications at the Highway Garage as detailed in the Change Order Document dated November 16, 2011, NOW, THEREFORE, BE IT

RESOLVED, that Change Order No. 1 for the aforementioned project in the amount of \$159,203.41 as a deduction to the contract of O'Connell Electric be and hereby is approved, AND, BE IT FURTHER

RESOLVED, that the Supervisor is hereby authorized and directed to execute Change Order No. 1 on behalf of this Town Board.

RESULT:	ADOPTED [UNANIMOUS]
MOVER:	Mary Holtz, Supervisor
SECONDER:	Jeff Swiatek, Councilmember
AYES:	Holtz, Jaworowicz, Swiatek, Rogowski, Zydel, Markel, Kaznowski



5. RESOLUTION 2011-600

Change Order No. 1 - Boring of a 21" Sanitary Sewer Under Dick Road/North Creek Drive

Sponsored By: Councilmember Kaznowski, Councilmember Zydel

WHEREAS, the contract for the Boring of a 21" Sanitary Sewer under Dick Road/North Creek Drive was awarded by Town Board Resolution dated July 18, 2011 to Kandey Company, Inc., 19 Ransier Drive, West Seneca, New York 14224 in the amount of \$109,427.00, AND

WHEREAS, the Project Engineer, Allan Blachowski, and the Town Engineer have recommended the approval of Change Order No. 1 which provides for modifications to the location of the bore pit into the roadway at the southeast intersection of North Creek Drive and Dick Road, concrete road barriers/flashers, extension of the 21" sanitary sewer beyond the 4" phone line and underground electric due to an elevation conflict with the Verizon concrete 8 ductbank, as further detailed in the change order document, NOW, THEREFORE, BE IT

RESOLVED, that Change Order No. 1 for the Boring of a 21" Sanitary Sewer under Dick Road/North Creek Drive, as an addition to the contract in the amount of \$11,315.11, be and hereby is approved, AND, BE IT FURTHER

RESOLVED, that the Supervisor is hereby authorized and directed to execute said Change Order No. 1 document on behalf of this Town Board.

RESULT:	ADOPTED [UNANIMOUS]
MOVER:	Stanley Kaznowski, Councilmember
SECONDER:	Richard Zydel, Councilmember
AYES:	Holtz, Jaworowicz, Swiatek, Rogowski, Zydel, Markel, Kaznowski



6. RESOLUTION 2011-601

Change Order - Asbestos Survey of 24E Glenwood Court

Sponsored By: Councilmember Markel, Councilmember Kaznowski

WHEREAS, the contract for a pre-demolition asbestos survey, specifications, and air monitoring services for the demolition for 24E Glenwood Court was awarded to 56 Services, Inc., by Resolution 2011-160, for the sum of \$1,400.00; and

WHEREAS, through inadvertence, technician time and air monitoring services during said demolition was not reflected therein, and will cost an additional \$2,925.00; and

WHEREAS, the Town's consultants, Nussbaumer & Clarke, recommend approval of a Change Order for such services; NOW, THEREFORE, BE IT

RESOLVED, that this Town Board hereby approves a Change Order for technician time and air monitoring services regarding the demolition of 24E Glenwood Court in the amount of \$2,295.00, and directs the supervisor to execute said Change Order; and be it further

RESOLVED, that moneys for said Change Order shall be appropriated from budget line item number 0800-800-0440.

RESULT:	ADOPTED [UNANIMOUS]
MOVER:	Charles Markel, Councilmember
SECONDER:	Stanley Kaznowski, Councilmember
AYES:	Holtz, Jaworowicz, Swiatek, Rogowski, Zydel, Markel, Kaznowski



7. RESOLUTION 2011-602

Change Order - Asbestos Survey of 27 Alpine Place

Sponsored By: Councilmember Markel, Councilmember Kaznowski

WHEREAS, the contract for a pre-demolition asbestos survey, specifications, and air monitoring services for the demolition for 27 Alpine Place was awarded to 56 Services, Inc., by Resolution 2011-161, for the sum of \$1,400.00; and

WHEREAS, through inadvertence, technician time and air monitoring services during said demolition was not reflected therein, and will cost an additional \$2,925.00; and

WHEREAS, the Town's consultants, Nussbaumer & Clarke, recommend approval of a Change Order for such services; NOW, THEREFORE, BE IT

RESOLVED, that this Town Board hereby approves a Change Order for technician time and air monitoring services regarding the demolition of 27 Alpine Place in the amount of \$2,295.00, and directs the supervisor to execute said Change Order; and be it further

RESOLVED, that moneys for said Change Order shall be appropriated from budget line item number 0800-800-0440.

RESULT:	ADOPTED [UNANIMOUS]
MOVER:	Charles Markel, Councilmember
SECONDER:	Stanley Kaznowski, Councilmember
AYES:	Holtz, Jaworowicz, Swiatek, Rogowski, Zydel, Markel, Kaznowski



8. RESOLUTION 2011-603

Notice to Bidders - One (1) New and Unused 2012 Model, Wheel Type, Asphalt Paver with a Variable Width, Power Extending Screed

Sponsored By: Councilmember Swiatek, Supervisor Holtz

NOTICE IS HEREBY GIVEN, that the Town of Cheektowaga Highway Department will receive bids for the purchase of One (1) New and Unused 2012 Model, Wheel Type, Asphalt Paver with a Variable Width, Power Extending Screed for use by the Highway Department in the Town of Cheektowaga at a public bid opening to be held in the Council Chambers at the Cheektowaga Town Hall on December 7, 2011 at 11:00 A.M.

Information for bidders specifications may be obtained from the office of the Town Clerk, Cheektowaga Town Hall, Broadway and Union Roads, Cheektowaga, New York, between the hour of 9:00 AM and 4:30 PM, Monday thru Friday, NOW THEREFORE BE IT

RESOLVED, that the Town Clerk is hereby designated as the Office to open bids on the aforesaid items at a public bid opening on Wednesday December 7, 2011, at 11:00 AM, in the Council Chambers of the Cheektowaga Town Hall.

TOWN OF CHEEKTOWAGA HIGHWAY DEPARTMENT
LEGAL NOTICE TO BIDDERS

NOTICE IS HEREBY GIVEN, that the Town of Cheektowaga Highway Department will receive bids for the purchase of One (1) New and Unused 2012 Model, Wheel Type, Asphalt Paver with a Variable Width, Power Extending Screed for use by the Highway Department in the Town of Cheektowaga at a public bid opening to be held in the Council Chambers at the Cheektowaga Town Hall on December 7, 2011 at 11:00 A.M.

Information for bidders and specifications may be obtained from the office of Alice Magierski, Town Clerk at her office located at Town Hall, Cheektowaga NY. Bids must be enclosed in an opaque envelope plainly marked "BID FOR ONE (1) NEW AND UNUSED 2012 MODEL, WHEEL TYPE ASPHALT PAVER WITH A VARIABLE WIDTH, POWER EXTENDING SCREED." Non-Collusion forms must be signed and submitted with each bid. The Superintendent of Highways may reject any or all bids submitted.

ALICE MAGIERSKI, TOWN CLERK

DATE: November 21, 2011

PUBLISHED: November 23, 2011

Table with 2 columns: Label (RESULT, MOVER, SECONDER, AYES) and Content (ADOPTED [UNANIMOUS], Jeff Swiatek, Councilmember, Mary Holtz, Supervisor, Holtz, Jaworowicz, Swiatek, Rogowski, Zydel, Markel, Kaznowski)



9. RESOLUTION 2011-604

Notice to Bidders - 2012 Ford F-550 Truck with 12' Stake Body

Sponsored By: Councilmember Rogowski, Councilmember Kaznowski

WHEREAS, the Town of Cheektowaga desires to purchase one (1) new and unused 2012 Ford F-550 Truck with 12' Stake Body, or equal, for use by the Facilities Department, NOW, THEREFORE, BE IT

RESOLVED, that this request be granted and that the Town Clerk be directed to publish a Notice to Bidders in connection with said purchase of one (1) new and unused 2012 Ford F-550 Truck with 12' Stake Body, or equal, said notice to be published in the CHEEKTOWAGA BEE, AND, BE IT FURTHER

RESOLVED, that sealed bids will be received and opened by the Town Clerk on the 7th day of December, 2011 at 11:00 am, at a public bid opening to be held in the Council Chambers at the Cheektowaga Town Hall.

NOTICE TO BIDDERS

Sealed proposals will be received by the Town of Cheektowaga on December 7, 2011 at 11:00 am, at the Town Hall, corner of Broadway and Union Roads, for the purchase of one (1) new and unused 2012 Ford F-550 Truck with 12' Stake Body, or equal.

Information for bidders and specifications may be obtained from the Town Clerk at her office in said Town.

The Town Board reserves the right to consider informal any bid not prepared and submitted in accordance with the provisions of the specifications and contract documents, and may waive any informalities, make an award to other than the low bidder, should it be in the best interest of the Town, or reject any or all bids.

By order of the Town Board of the Town of Cheektowaga, Erie County, New York.

Alice Magierski
Town Clerk

DATED: November 21, 2011

Table with 2 columns: Field (RESULT, MOVER, SECONDER, AYES) and Value (ADOPTED [UNANIMOUS], James Rogowski, Stanley Kaznowski, Holtz, Jaworowicz, Swiatek, Rogowski, Zydel, Markel, Kaznowski)



10. RESOLUTION 2011-605

Notice to Bidders - One (1) New and Unused 2011 20' Scissor Lift

Sponsored By: Councilmember Rogowski, Councilmember Kaznowski

WHEREAS, the Town of Cheektowaga desires to purchase one (1) new and unused 2011 20' Scissor Lift for use by the Buildings & Grounds Division, NOW, THEREFORE, BE IT

RESOLVED, that this request be granted and that the Town Clerk be directed to publish a Notice to Bidders in connection with said purchase of one (1) new and unused 2011 20' Scissor Lift, said notice to be published in the CHEEKTOWAGA BEE, AND, BE IT FURTHER

RESOLVED, that sealed bids will be received and opened by the Town Clerk on the 7th day of December, 2011 at 11:00 am, at a public bid opening to be held in the Council Chambers at the Cheektowaga Town Hall.

NOTICE TO BIDDERS

Sealed proposals will be received by the Town of Cheektowaga on December 7, 2011 at 11:00 at the Town Hall, corner of Broadway and Union Road, for the purchase of one (1) new and unused 2011 20' Scissor Lift.

Information for bidders and specifications may be obtained from the Town Clerk at her office in said Town.

The Town Board reserves the right to consider informal any bid not prepared and submitted in accordance with the provisions of the specifications and contract documents, and may waive any informalities, make an award to other than the low bidder, should it be in the best interest of the Town, or reject any or all bids.

By order of the Town Board of the Town of Cheektowaga, Erie County, New York.

Alice Magierski
Town Clerk

DATED: November 21, 2011

Table with 2 columns: Field (RESULT, MOVER, SECONDER, AYES) and Value (ADOPTED [UNANIMOUS], James Rogowski, Stanley Kaznowski, Holtz, Jaworowicz, Swiatek, Rogowski, Zydel, Markel, Kaznowski)



11. RESOLUTION 2011-606

Negative SEQR Declaration - 4243 Genesee Street- Marriott Town Place Suites

Sponsored By: Councilmember Kaznowski, Councilmember Markel

WHEREAS, pursuant to the Environmental Impact Review Ordinance of the Town of Cheektowaga, the Environmental Advisory Committee ("EAC") reviews various applications for site plans, rezonings, special permits, etc. and renders its recommendation concerning the environmental significance of such application, AND

WHEREAS, the Town Board, pursuant to the Environmental Impact Review Ordinance of the Town of Cheektowaga, is designated the Lead Agency in most instances, AND

WHEREAS, since the Town Board is the Lead Agency, it must affirm, modify or reject any recommendations submitted to it by the Advisory Committee, AND

WHEREAS, an application was submitted by Benderson Development Co., LLC. for the construction of a (4) story 119 room hotel at 4243 Genesee Street, AND

WHEREAS, the Environmental Advisory Committee at its meetings held on November 2, 2011 recommended a determination of non-significance as shown on the attached memorandum dated November 3, 2011, AND

WHEREAS, the Town of Cheektowaga Planning Board recommended approval of the site plan at their meeting of October 13, 2011, AND

WHEREAS, the subject project required an area variance to exceed the maximum height allowed in proximity to the Buffalo Niagara International Airport, AND

WHEREAS, the Cheektowaga Zoning Board of Appeals granted the necessary area variance to permit the proposed hotel height of 56 feet, as shown on the attached resolution dated November 10, 2011, AND

WHEREAS, the Federal Aviation Administration (FAA) has reviewed the proposed building location and height for conflicts with navigable air space, and has permitted a maximum building height of 56 feet as shown on the attached correspondence dated October 31, 2001, AND

WHEREAS, this Town Board has reviewed the application submitted and the recommendations made by the Environmental Advisory Committee, the Planning Board and the the Zoning Board of Appeals and the NOW, THEREFORE, BE IT

RESOLVED, that this Town Board determines that the project will not have a significant effect on the environment and therefore issues a Negative Declaration for purposes of SEQRA, AND BE IT

FURTHER RESOLVED, the proposed site plan is found to be acceptable subject to :

1. The Town Engineer reviewing and approving the grading/drainage plan.

Attachments:

TownePlace Suites - FAA Approval (PDF)

EAC Minutes Dated November 3, 2011 (PDF)

Site Plan (PDF)

4243 genesee street area variance (PDF)

RESULT: **ADOPTED [UNANIMOUS]**

MOVER: Stanley Kaznowski, Councilmember

SECONDER: Charles Markel, Councilmember

AYES: Holtz, Jaworowicz, Swiatek, Rogowski, Zydel, Markel, Kaznowski



12. RESOLUTION 2011-607

Negative SEQR Declaration - 105 Affinity Lane Collegiate Village Concessions Building

Sponsored By: Councilmember Kaznowski, Councilmember Markel

WHEREAS, pursuant to the Environmental Impact Review Ordinance of the Town of Cheektowaga, the Environmental Advisory Committee ("EAC") reviews various applications for site plans, rezonings, special permits, etc. and renders its recommendation concerning the environmental significance of such application, AND

WHEREAS, the Town Board, pursuant to the Environmental Impact Review Ordinance of the Town of Cheektowaga, is designated the Lead Agency in most instances, AND

WHEREAS, since the Town Board is the Lead Agency, it must affirm, modify or reject any recommendations submitted to it by the Advisory Committee, AND

WHEREAS, an application was submitted by Lauer-Manguso & Associates, Architects for the construction of a 4,500 square foot concessions building addition to an existing community building at 105 Affinity Lane, AND

WHEREAS, the Environmental Advisory Committee at its meetings held on November 2, 2011 recommended a determination of non-significance as shown on the attached memorandum dated November 3, 2011, AND

WHEREAS, the Town of Cheektowaga Planning Board recommended approval of the site plan at their meeting of October 13, 2011, AND

WHEREAS, the Town of Cheektowaga Traffic Safety Commission has reviewed the subject project and is recommending its approval, AND

WHEREAS, this Town Board has reviewed the application submitted and the recommendations made by the Environmental Advisory Committee, the Planning Board and the Traffic Safety Commission, NOW, THEREFORE, BE IT

RESOLVED, that this Town Board determines that the project will not have a significant effect on the environment and therefore issues a Negative Declaration for purposes of SEQRA, AND BE IT

FURTHER RESOLVED, the proposed site plan is found to be acceptable subject to :

1. The Town Engineer reviewing and approving the grading/drainage plan.

Attachments:

site plan collegiate village (PDF)

EAC Minutes Dated November 3, 2011 (PDF)

RESULT:	ADOPTED [UNANIMOUS]
MOVER:	Stanley Kaznowski, Councilmember
SECONDER:	Charles Markel, Councilmember
AYES:	Holtz, Jaworowicz, Swiatek, Rogowski, Zydel, Markel, Kaznowski



13. RESOLUTION 2011-608

Authorize Supervisor to Execute an Agreement with Child & Family Services for Domestic Violence Services

Sponsored By: Councilmember Markel, Councilmember Kaznowski

WHEREAS, Community Development Block Grant Funds have been budgeted for a Domestic Violence Prevention Program, AND

WHEREAS, the Town entered an agreement with Child and Family Services of Erie County in 2010 for the provision of domestic violence victim advocate program services for Town residents, AND

WHEREAS, the Director of Community Development has recommended that the Town extend said agreement for 2011 in an amount not to exceed \$10,000 for said program, NOW THEREFORE BE IT

RESOLVED, that the Supervisor be and hereby is authorized and directed to execute an extension of the 2010 agreement with Child and Family Services of Erie County, 330 Delaware Avenue, Buffalo, New York 14202, to fund Domestic Violence Victim Advocate Program services for Town residents for 2011 in an amount not to exceed \$10,000, AND BE IT

FURTHER RESOLVED, that said program be funded with Community Development Block Grant funds.

RESULT:	ADOPTED [UNANIMOUS]
MOVER:	Charles Markel, Councilmember
SECONDER:	Stanley Kaznowski, Councilmember
AYES:	Holtz, Jaworowicz, Swiatek, Rogowski, Zydel, Markel, Kaznowski



14. RESOLUTION 2011-609

Authorize Supervisor to Execute Letter of Agreement with VA WNY Health Care System

Sponsored By: Councilmember Jaworowicz, Councilmember Rogowski

WHEREAS, the Veterans Affairs Western New York Healthcare System (hereinafter "VA WNY Health Care System") requires that it maintain written support agreements with local law enforcement agencies, and

WHEREAS, the VA WNY Health Care System has requested that the Town of Cheektowaga execute an agreement with it to permit the Town of Cheektowaga Police Department to assist it if necessary, and

WHEREAS, this Town Board wishes to cooperate with the United States government and the VA WNY Health Care System to provide assistance when so requested, NOW, THEREFORE, BE IT

RESOLVED, that the Supervisor be and hereby is authorized and directed to execute a letter of agreement with the VA WNY Health Care System for law enforcement assistance.

RESULT:	ADOPTED [UNANIMOUS]
MOVER:	Patricia Jaworowicz, Councilmember
SECONDER:	James Rogowski, Councilmember
AYES:	Holtz, Jaworowicz, Swiatek, Rogowski, Zydel, Markel, Kaznowski



15. RESOLUTION 2011-610

Authorize Supervisor to Execute Memorandum of Understanding with U.S. Secret Service

Sponsored By: Councilmember Jaworowicz, Councilmember Rogowski

WHEREAS, the Town of Cheektowaga Police Department has worked with the United States Secret Service on occasion on criminal matters under Federal jurisdiction, and

WHEREAS, the United States Secret Service has prepared a Memorandum of Understanding wherein it commits to reimburse the Town of Cheektowaga Police Department for the payment of overtime costs and other expenses directly related to work performed by Town police officers assigned to assist the United States Secret Service's Buffalo Field Office, NOW, THEREFORE, BE IT

RESOLVED, that the Supervisor be and hereby is authorized and directed to execute the aforementioned Memorandum of Understanding with the United States Secret Service.

RESULT:	ADOPTED [UNANIMOUS]
MOVER:	Patricia Jaworowicz, Councilmember
SECONDER:	James Rogowski, Councilmember
AYES:	Holtz, Jaworowicz, Swiatek, Rogowski, Zydel, Markel, Kaznowski



16. RESOLUTION 2011-611

Authorize Supervisor to Execute Agreement with National Grid To Attach Holiday Decorations to Electrical Poles

Sponsored By: Councilmember Zydel, Councilmember Rogowski

WHEREAS, during the holiday season, the Town of Cheektowaga usually attaches decorations to electrical poles throughout the town; and

WHEREAS, National Grid is the owner of electrical poles in a portion of the Town of Cheektowaga; and

WHEREAS, National Grid has notified the Town of Cheektowaga that, if we decide to attach decorations to National Grid's poles, the Town needs to execute an agreement with National Grid; and

WHEREAS, the Youth & Recreational Services Department is interested in attaching holiday decorations to National Grid's electrical poles; NOW, THEREFORE, BE IT

RESOLVED, that the Supervisor be and hereby is authorized and directed to execute an agreement with National Grid and any other documents necessary to permit the Town to attach holiday decorations to the electrical poles of National Grid.

RESULT:	ADOPTED [UNANIMOUS]
MOVER:	Richard Zydel, Councilmember
SECONDER:	James Rogowski, Councilmember
AYES:	Holtz, Jaworowicz, Swiatek, Rogowski, Zydel, Markel, Kaznowski



17. RESOLUTION 2011-612

Unsafe-Unsecured / 121 Pleasant Parkway

Sponsored By: Councilmember Markel, Councilmember Kaznowski

WHEREAS, Town of Cheektowaga Law for the Administration and Enforcement of the Codes of New York State; and the Property Maintenance Code of New York State require that all vacant structures and premises shall be maintained in clean, safe, secure and sanitary conditions so as not to cause a blighting problem or adversely affect the public health or safety and all nuisances abated, AND

WHEREAS, the Town of Cheektowaga has received notification of an unsafe structure and premises located at 121 Pleasant Parkway, Cheektowaga, New York SBL# 123.28-1-13 that is a danger to the safety of others, and records kept by the Assessors Office identify Karyn Sajdak, 121 Pleasant Parkway, Cheektowaga, New York 14206-3345, as the owner AND

WHEREAS, an inspection of such premises was conducted at 121 Pleasant Parkway, by the Housing and Neighborhood Preservation Office, AND

WHEREAS, such inspection found the premises to be deteriorated, vacant, a hazard, and a danger to the safety and well being of others, AND

WHEREAS, the Town of Cheektowaga Housing and Neighborhood Preservation Office properly notified the property owner in accordance with the Town of Cheektowaga Law for the Administration and Enforcement of the Codes of New York State, and the owner failed to take actions to safeguard the premises, AND

WHEREAS, these conditions require the Town of Cheektowaga Housing and Neighborhood Preservation Office to take immediate steps to safeguard the premises to protect the health and safety of others and abate all nuisances, NOW, THEREFORE BE IT

RESOLVED, that pursuant to Section 70-7A.(5) and Section 70-8 of the Town of Cheektowaga Law for the Administration and Enforcement of the Codes of New York State that the vacant structure premises be safeguarded and all nuisances abated; and all costs incurred be assessed against the property hereinbefore described.

RESULT:	ADOPTED [UNANIMOUS]
MOVER:	Charles Markel, Councilmember
SECONDER:	Stanley Kaznowski, Councilmember
AYES:	Holtz, Jaworowicz, Swiatek, Rogowski, Zydel, Markel, Kaznowski



18. RESOLUTION 2011-613

Unsafe-Unsecured / 257 Chapel Avenue

Sponsored By: Councilmember Markel, Councilmember Kaznowski

WHEREAS, Town of Cheektowaga Law for the Administration and Enforcement of the Codes of New York State; and the Property Maintenance Code of New York State require that all vacant structures and premises shall be maintained in clean, safe, secure and sanitary conditions so as not to cause a blighting problem or adversely affect the public health or safety and all nuisances abated, AND

WHEREAS, the Town of Cheektowaga has received notification of an unsafe structure and premises located at 257 Chapel Avenue, Cheektowaga, New York SBL# 92.17-2-17 that is a danger to the safety of others, and records kept by the Assessors Office identify James J. Gauthier, 143 Claudette Court, Cheektowaga, New York 14225 and Gail K. James, 257 Chapel Avenue, Cheektowaga, New York 14225, as the owner AND

WHEREAS, an inspection of such premises was conducted at 257 Chapel Avenue, by the Housing and Neighborhood Preservation Office, AND

WHEREAS, such inspection found the premises to be deteriorated, vacant, a hazard, and a danger to the safety and well being of others, AND

WHEREAS, the Town of Cheektowaga Housing and Neighborhood Preservation Office properly notified the property owner in accordance with the Town of Cheektowaga Law for the Administration and Enforcement of the Codes of New York State, and the owner failed to take actions to safeguard the premises, AND

WHEREAS, these conditions require the Town of Cheektowaga Housing and Neighborhood Preservation Office to take immediate steps to safeguard the premises to protect the health and safety of others and abate all nuisances, NOW, THEREFORE BE IT

RESOLVED, that pursuant to Section 70-7A.(5) and Section 70-8 of the Town of Cheektowaga Law for the Administration and Enforcement of the Codes of New York State that the vacant structure premises be safeguarded and all nuisances abated; and all costs incurred be assessed against the property hereinbefore described.

RESULT:	ADOPTED [UNANIMOUS]
MOVER:	Charles Markel, Councilmember
SECONDER:	Stanley Kaznowski, Councilmember
AYES:	Holtz, Jaworowicz, Swiatek, Rogowski, Zydel, Markel, Kaznowski



19. RESOLUTION 2011-614

Unsafe-Unsecured / 1272 Walden Avenue

Sponsored By: Councilmember Markel, Councilmember Kaznowski

WHEREAS, Town of Cheektowaga Law for the Administration and Enforcement of the Codes of New York State; and the Property Maintenance Code of New York State require that all vacant structures and premises shall be maintained in clean, safe, secure and sanitary conditions so as not to cause a blighting problem or adversely affect the public health or safety and all nuisances abated, AND

WHEREAS, the Town of Cheektowaga has received notification of an unsafe structure and premises located at 1272 Walden Avenue, Cheektowaga, New York SBL# 102.53-4-15.1 that is a danger to the safety of others, and records kept by the Assessors Office identify JB Ventures LLC, 18685 Main Street, Suite 101, Huntington Beach, California 92648-1719, as the owner AND

WHEREAS, an inspection of such premises was conducted at 1272 Walden Avenue, by the Housing and Neighborhood Preservation Office, AND

WHEREAS, such inspection found the premises to be deteriorated, vacant, a hazard, and a danger to the safety and well being of others, AND

WHEREAS, the Town of Cheektowaga Housing and Neighborhood Preservation Office properly notified the property owner in accordance with the Town of Cheektowaga Law for the Administration and Enforcement of the Codes of New York State, and the owner failed to take actions to safeguard the premises, AND

WHEREAS, these conditions require the Town of Cheektowaga Housing and Neighborhood Preservation Office to take immediate steps to safeguard the premises to protect the health and safety of others and abate all nuisances, NOW, THEREFORE BE IT

RESOLVED, that pursuant to Section 70-7A.(5) and Section 70-8 of the Town of Cheektowaga Law for the Administration and Enforcement of the Codes of New York State that the vacant structure premises be safeguarded and all nuisances abated; and all costs incurred be assessed against the property hereinbefore described.

RESULT:	ADOPTED [UNANIMOUS]
MOVER:	Charles Markel, Councilmember
SECONDER:	Stanley Kaznowski, Councilmember
AYES:	Holtz, Jaworowicz, Swiatek, Rogowski, Zydel, Markel, Kaznowski



20. RESOLUTION 2011-615

Unsafe-Unsecured / 166 Straley Avenue

Sponsored By: Councilmember Markel, Councilmember Kaznowski

WHEREAS, Town of Cheektowaga Law for the Administration and Enforcement of the Codes of New York State; and the Property Maintenance Code of New York State require that all vacant structures and premises shall be maintained in clean, safe, secure and sanitary conditions so as not to cause a blighting problem or adversely affect the public health or safety and all nuisances abated, AND

WHEREAS, the Town of Cheektowaga has received notification of an unsafe structure and premises located at 166 Straley Avenue, Cheektowaga, New York SBL# 102.37-2-13 that is a danger to the safety of others, and records kept by the Assessors Office identify Kathryn Barajas, 166 Straley Avenue, Cheektowaga, New York 14211, as the owner AND

WHEREAS, an inspection of such premises was conducted at 166 Straley Avenue, by the Housing and Neighborhood Preservation Office, AND

WHEREAS, such inspection found the premises to be deteriorated, vacant, a hazard, and a danger to the safety and well being of others, AND

WHEREAS, the Town of Cheektowaga Housing and Neighborhood Preservation Office properly notified the property owner in accordance with the Town of Cheektowaga Law for the Administration and Enforcement of the Codes of New York State, and the owner failed to take actions to safeguard the premises, AND

WHEREAS, these conditions require the Town of Cheektowaga Housing and Neighborhood Preservation Office to take immediate steps to safeguard the premises to protect the health and safety of others and abate all nuisances, NOW, THEREFORE BE IT

RESOLVED, that pursuant to Section 70-7A.(5) and Section 70-8 of the Town of Cheektowaga Law for the Administration and Enforcement of the Codes of New York State that the vacant structure premises be safeguarded and all nuisances abated; and all costs incurred be assessed against the property hereinbefore described.

RESULT:	ADOPTED [UNANIMOUS]
MOVER:	Charles Markel, Councilmember
SECONDER:	Stanley Kaznowski, Councilmember
AYES:	Holtz, Jaworowicz, Swiatek, Rogowski, Zydel, Markel, Kaznowski



21. RESOLUTION 2011-616

Unsafe-Unsecured / 70 Shanley Street

Sponsored By: Councilmember Markel, Councilmember Kaznowski

WHEREAS, Town of Cheektowaga Law for the Administration and Enforcement of the Codes of New York State; and the Property Maintenance Code of New York State require that all vacant structures and premises shall be maintained in clean, safe, secure and sanitary conditions so as not to cause a blighting problem or adversely affect the public health or safety and all nuisances abated, AND

WHEREAS, the Town of Cheektowaga has received notification of an unsafe structure and premises located at 70 Shanley Street, Cheektowaga, New York SBL# 123.27-10-8 that is a danger to the safety of others, and records kept by the Assessors Office identify Christine Wisniewski, 50 North Avenue, Apartment 237, West Seneca, New York 14224, as the owner AND

WHEREAS, an inspection of such premises was conducted at 70 Shanley Street, by the Housing and Neighborhood Preservation Office, AND

WHEREAS, such inspection found the premises to be deteriorated, vacant, a hazard, and a danger to the safety and well being of others, AND

WHEREAS, the Town of Cheektowaga Housing and Neighborhood Preservation Office properly notified the property owner in accordance with the Town of Cheektowaga Law for the Administration and Enforcement of the Codes of New York State, and the owner failed to take actions to safeguard the premises, AND

WHEREAS, these conditions require the Town of Cheektowaga Housing and Neighborhood Preservation Office to take immediate steps to safeguard the premises to protect the health and safety of others and abate all nuisances, NOW, THEREFORE BE IT

RESOLVED, that pursuant to Section 70-7A.(5) and Section 70-8 of the Town of Cheektowaga Law for the Administration and Enforcement of the Codes of New York State that the vacant structure premises be safeguarded and all nuisances abated; and all costs incurred be assessed against the property hereinbefore described.

RESULT:	ADOPTED [UNANIMOUS]
MOVER:	Charles Markel, Councilmember
SECONDER:	Stanley Kaznowski, Councilmember
AYES:	Holtz, Jaworowicz, Swiatek, Rogowski, Zydel, Markel, Kaznowski



22. RESOLUTION 2011-617

Unsafe Premises / 95 Wellworth Place

Sponsored By: Councilmember Markel, Councilmember Kaznowski

WHEREAS, Town of Cheektowaga Law for the Administration and Enforcement of the Codes of New York State; and the Property Maintenance Code of New York State require that all vacant structures and premises shall be maintained in clean, safe, secure and sanitary conditions so as not to cause a blighting problem or adversely affect the public health or safety and all nuisances abated, AND

WHEREAS, the Town of Cheektowaga has received notification of an unsafe structure and premises located at 95 Wellworth Place, Cheektowaga, New York SBL# 91.20-11-17 that is a danger to the safety of others, and records kept by the Assessors Office identify Acorn Management Services LLC, 69 Delaware Avenue Suite 1003, Buffalo, New York 14202, as the owner AND

WHEREAS, an inspection of such premises was conducted at 95 Wellworth Place, by the Housing and Neighborhood Preservation Office, AND

WHEREAS, such inspection found the premises to be deteriorated, vacant, a hazard, and a danger to the safety and well being of others, AND

WHEREAS, the Town of Cheektowaga Housing and Neighborhood Preservation Office properly notified the property owner in accordance with the Town of Cheektowaga Law for the Administration and Enforcement of the Codes of New York State, and the owner failed to take actions to safeguard the premises, AND

WHEREAS, these conditions require the Town of Cheektowaga Housing and Neighborhood Preservation Office to take immediate steps to safeguard the premises to protect the health and safety of others and abate all nuisances, NOW, THEREFORE BE IT

RESOLVED, that pursuant to Section 70-7A.(5) and Section 70-8 of the Town of Cheektowaga Law for the Administration and Enforcement of the Codes of New York State that the vacant structure premises be safeguarded and all nuisances abated; and all costs incurred be assessed against the property hereinbefore described.

RESULT:	ADOPTED [UNANIMOUS]
MOVER:	Charles Markel, Councilmember
SECONDER:	Stanley Kaznowski, Councilmember
AYES:	Holtz, Jaworowicz, Swiatek, Rogowski, Zydel, Markel, Kaznowski



23. RESOLUTION 2011-618

Unsafe Accessory Structure(Fence) / 25 Dennis Lane

Sponsored By: Councilmember Markel, Councilmember Kaznowski

WHEREAS, Town of Cheektowaga Law for the Administration and Enforcement of the Codes of New York State; and the Property Maintenance Code of New York State require that all vacant structures and premises shall be maintained in clean, safe, secure and sanitary conditions so as not to cause a blighting problem or adversely affect the public health or safety and all nuisances abated, AND

WHEREAS, the Town of Cheektowaga has received notification of an unsafe structure and premises located at 25 Dennis Lane, Cheektowaga, New York SBL# 113.42-1-32 that is a danger to the safety of others, and records kept by the Assessors Office identify Casimer P. Glowny, 25 Dennis Lane, Cheektowaga, New York 14227-1301, as the owner AND

WHEREAS, an inspection of such premises was conducted at 25 Dennis Lane, by the Housing and Neighborhood Preservation Office, AND

WHEREAS, such inspection found the premises to be deteriorated, vacant, a hazard, and a danger to the safety and well being of others, AND

WHEREAS, the Town of Cheektowaga Housing and Neighborhood Preservation Office properly notified the property owner in accordance with the Town of Cheektowaga Law for the Administration and Enforcement of the Codes of New York State, and the owner failed to take actions to safeguard the premises, AND

WHEREAS, these conditions require the Town of Cheektowaga Housing and Neighborhood Preservation Office to take immediate steps to safeguard the premises to protect the health and safety of others and abate all nuisances, NOW, THEREFORE BE IT

RESOLVED, that pursuant to Section 70-7A.(5) and Section 70-8 of the Town of Cheektowaga Law for the Administration and Enforcement of the Codes of New York State that the vacant structure premises be safeguarded and all nuisances abated; and all costs incurred be assessed against the property hereinbefore described.

RESULT:	ADOPTED [UNANIMOUS]
MOVER:	Charles Markel, Councilmember
SECONDER:	Stanley Kaznowski, Councilmember
AYES:	Holtz, Jaworowicz, Swiatek, Rogowski, Zydel, Markel, Kaznowski



24. RESOLUTION 2011-619

Reinstatement of Public Safety Dispatcher (Police Department/Keith A. Wesolek)

Sponsored By: Councilmember Jaworowicz, Councilmember Swiatek

BE IT RESOLVED, that Keith A. Wesolek of Depew, New York, be and hereby is reinstated to the title of Public Safety Dispatcher in the Police Department in compliance with Civil Service Laws and Regulations effective November 22, 2011.

RESULT:	ADOPTED [UNANIMOUS]
MOVER:	Patricia Jaworowicz, Councilmember
SECONDER:	Jeff Swiatek, Councilmember
AYES:	Holtz, Jaworowicz, Swiatek, Rogowski, Zydel, Markel, Kaznowski



25. RESOLUTION 2011-620

Transfer Court Officers Under Police Department Supervision

Sponsored By: Holtz, Swiatek, Jaworowicz, Rogowski, Zydel, Markel, Kaznowski

WHEREAS, the Town of Cheektowaga currently employs part-time Court Officers to ensure the security of the Justice Court; AND

WHEREAS, said Court Officers are currently supervised by the Justice Court; AND

WHEREAS, the Town also currently employs part-time Detention Officers who are responsible for the detention of prisoners; AND

WHEREAS, said Detention Officers are currently supervised by the Police Department; AND

WHEREAS, the construction of the new court facility has presented the Town Board an opportunity to review the security operation of the Justice Court in relation to the public, staff and prisoners; AND

WHEREAS, it is the opinion of this Town Board that both court security and prisoner detention be supervised by one department to ensure both the efficiency and effectiveness of these functions; NOW, THEREFORE, BE IT

RESOLVED, that the supervision of Court Officers be and hereby is transferred from the Justice Court to the Police Department, effective January 1, 2012.

RESULT:	ADOPTED [UNANIMOUS]
MOVER:	Mary Holtz, Supervisor
SECONDER:	Jeff Swiatek, Councilmember
AYES:	Holtz, Jaworowicz, Swiatek, Rogowski, Zydel, Markel, Kaznowski



26. RESOLUTION 2011-621

Transfer Sign Maintenance Division Under Supervision of Highway Department

Sponsored By: Holtz, Swiatek, Jaworowicz, Rogowski, Zydel, Markel, Kaznowski

WHEREAS, the Traffic Sign Maintenance Division of the Town of Cheektowaga is currently supervised by the Police Department; AND

WHEREAS, this Town Board has reviewed both the efficiency and effectiveness of the function and staff of said division of the Police Department; AND

WHEREAS, it is the opinion of this Town Board that the function and staff of the Traffic Sign Maintenance Division will be enhanced by transferring supervision from the Police Department to the Highway Department; NOW, THEREFORE, BE IT

RESOLVED, that the supervision of the Traffic Sign Maintenance Division be and hereby is transferred from the Police Department to the Highway Department, effective January 1, 2012.

RESULT:	ADOPTED [UNANIMOUS]
MOVER:	Mary Holtz, Supervisor
SECONDER:	Jeff Swiatek, Councilmember
AYES:	Holtz, Jaworowicz, Swiatek, Rogowski, Zydel, Markel, Kaznowski

**27. RESOLUTION 2011-622****Transfer Clerk Typist (Part Time) to Clerk (Part Time) (Jill M. Baszczyński/Justice Court)**

Sponsored By: Councilmember Jaworowicz, Councilmember Swiatek

WHEREAS, the appointment of a Clerk Typist (Part Time) was approved by this Town Board due to a short-term leave of absence in the Justice Court; AND

WHEREAS, Jill M. Baszczyński was appointed to said position effective September 6, 2011; AND

WHEREAS, the permanent employee on the short-term leave of absence has returned to full duty; NOW, THEREFORE, BE IT

RESOLVED, that Jill M. Baszczyński of Cheektowaga, New York, be transferred from the title of Clerk Typist (Part Time) to the position of Clerk (Part Time) in the Justice Court not to exceed nineteen (19) hours on a weekly basis, in compliance with Civil Service Laws and Regulations as well as the provisions of the Town's collective bargaining agreement between the Town of Cheektowaga and the Town of Cheektowaga Employees Association at the rate of \$8.00 an hour effective November 7, 2011.

RESULT:	ADOPTED [UNANIMOUS]
MOVER:	Patricia Jaworowicz, Councilmember
SECONDER:	Jeff Swiatek, Councilmember
AYES:	Holtz, Jaworowicz, Swiatek, Rogowski, Zydel, Markel, Kaznowski



28. RESOLUTION 2011-623

Youth & Recreation Hiring

Sponsored By: Councilmember Zydell, Councilmember Rogowski

BE IT RESOLVED that the individuals listed below be and hereby are hired and/or transferred, as indicated, in the Department of Youth & Recreational Services, effective immediately:

Recreation Aide - 7140.1614 - \$7.25 - Part-time

Elizabeth Meyerhofer	14225
Samantha Pinkowski	14206

Motion by Councilmember Rogowski; Seconded by Councilmember Kaznowski to waive the Reading of Names for the following two resolutions: 2011-623 and 2011-624. Motion Carried

RESULT:	ADOPTED [UNANIMOUS]
MOVER:	Richard Zydell, Councilmember
SECONDER:	James Rogowski, Councilmember
AYES:	Holtz, Jaworowicz, Swiatek, Rogowski, Zydell, Markel, Kaznowski



29. RESOLUTION 2011-624

Hiring/Termination of Part-Time/Seasonal Employees

Sponsored By: Councilmember Swiatek, Supervisor Holtz

BE IT RESOLVED, that the following individuals be and hereby are hired as **PART-TIME EMPLOYEES** in the departments listed, not to exceed nineteen (19) hours on a weekly basis, in compliance with Civil Service Laws and Regulations as well as the provisions of the Town's collective bargaining agreement between the Town of Cheektowaga and the Town of Cheektowaga Employees Association:

POLICE DEPARTMENT Supervising School Crossing Guard \$10.75/hour effective 11/7/11
Arthur F. Page, Cheektowaga, New York

POLICE DEPARTMENT Dog Control Officer \$10.25/hour effective 11/21/11
Christine Ellis-Prusiecki, Cheektowaga, New York

BE IT RESOLVED, that the following seasonal and/or part-time employees be and hereby are terminated as listed:

RECORDS MANAGEMENT
Lindsay Kaznowski effective 6/25/11
Christopher Hannel effective 10/28/11

FACILITIES DEPARTMENT (Parks Division & Building Maintenance Division)
Alex Kluck effective 10/26/11
Kyle Lackie effective 10/25/11
Drew Pijacki effective 10/18/11

RESULT:	ADOPTED [UNANIMOUS]
MOVER:	Jeff Swiatek, Councilmember
SECONDER:	Mary Holtz, Supervisor
AYES:	Holtz, Jaworowicz, Swiatek, Rogowski, Zydel, Markel, Kaznowski



30. RESOLUTION 2011-625

Travel Authorization Justice Court (Paul S. Piotrowski, Esq.)

Sponsored By: Councilmember Jaworowicz, Councilmember Swiatek

WHEREAS, a training entitled "Taking the Bench" is being held December 1 through December 3, 2011 (Session One) and December 8 through December 10, 2011 (Session Two) in East Syracuse, New York; AND

WHEREAS, Paul Piotrowski has requested authorization to attend said training sessions; AND

WHEREAS, Town Justice Thomas Kolbert has submitted a request for travel authorization along with the proper paperwork in a timely manner; AND

WHEREAS, the total cost to the Town shall not exceed \$1,000.20; AND

WHEREAS, these expenses have been budgeted by the Justice Court; NOW, THEREFORE, BE IT

RESOLVED, that Paul Piotrowski be and hereby is authorized to attend the training sessions entitled "Taking the Bench" being held December 1 through December 3, 2011 (Session One) and December 8 through December 10, 2011 (Session Two) in East Syracuse, New York.

RESULT:	ADOPTED [UNANIMOUS]
MOVER:	Patricia Jaworowicz, Councilmember
SECONDER:	Jeff Swiatek, Councilmember
AYES:	Holtz, Jaworowicz, Swiatek, Rogowski, Zydel, Markel, Kaznowski

V. Communications

A. Departmental Communications

1. Minutes: Cheektowaga Traffic Safety Commission - October 18, 2011
2. Minutes: Cheektowaga Conservation Advisory Council - November 3, 2011

B. General Communications

1. Notice of Claim: Shelley Matthews Vs. Town of Cheektowaga
2. Notice of Claim: Scott & Juliane Polino Vs Town of Cheektowaga
3. Notice of Claim: Henry Primm Vs. Town of Cheektowaga
4. Notice of Claim: Robert Szydowski Vs. Town of Cheektowaga

VI. Comments

A. Supervisor's Comments

B. Councilmember's Comments

C. Public Comments

VII. Adjournment

Motion by Supervisor Holtz; Seconded by Councilmember Swiatek to adjourn the meeting.
Time 7:24 PM

Alice Magierski, Town Clerk



Mail Processing Center
 Federal Aviation Administration
 Southwest Regional Office
 Obstruction Evaluation Group
 2601 Meacham Boulevard
 Fort Worth, TX 76137

Aeronautical Study No
 2011-AEA-3957-OE

4.11.a

Issued Date: 10/31/2011

William C. Rae
 Benderson Development Co., LLC
 570 Delaware Ave
 Buffalo, NY 14202

**** DETERMINATION OF NO HAZARD TO AIR NAVIGATION ****

The Federal Aviation Administration has conducted an aeronautical study under the provisions of 49 U.S.C., Section 44718 and if applicable Title 14 of the Code of Federal Regulations, part 77, concerning:

Structure: Building Townplace Suites
 Location: Cheektowaga, NY, NY
 Latitude: 42-55-48.84N NAD 83
 Longitude: 78-43-41.00W
 Heights: 682 feet site elevation (SE)
 56 feet above ground level (AGL)
 738 feet above mean sea level (AMSL)

This aeronautical study revealed that the structure does not exceed obstruction standards and would not be a hazard to air navigation provided the following condition(s), if any, is(are) met:

It is required that FAA Form 7460-2, Notice of Actual Construction or Alteration, be completed and returned to this office any time the project is abandoned or:

- At least 10 days prior to start of construction (7460-2, Part I)
- Within 5 days after the construction reaches its greatest height (7460-2, Part II)

Based on this evaluation, marking and lighting are not necessary for aviation safety. However, if marking/lighting are accomplished on a voluntary basis, we recommend it be installed and maintained in accordance with FAA Advisory circular 70/7460-1 K Change 2.

The structure considered under this study lies in proximity to an airport and occupants may be subjected to noise from aircraft operating to and from the airport.

This determination expires on 05/01/2013 unless:

- (a) extended, revised or terminated by the issuing office.
- (b) the construction is subject to the licensing authority of the Federal Communications Commission (FCC) and an application for a construction permit has been filed, as required by the FCC, within 6 months of the date of this determination. In such case, the determination expires on the date prescribed by the FCC for completion of construction, or the date the FCC denies the application.

NOTE: REQUEST FOR EXTENSION OF THE EFFECTIVE PERIOD OF THIS DETERMINATION MUST BE E-FILED AT LEAST 15 DAYS PRIOR TO THE EXPIRATION DATE. AFTER RE-EVALUATION OF CURRENT OPERATIONS IN THE AREA OF THE STRUCTURE TO DETERMINE THAT NO SIGNIFICANT AERONAUTICAL CHANGES HAVE OCCURRED, YOUR DETERMINATION MAY BE ELIGIBLE FOR ONE EXTENSION OF THE EFFECTIVE PERIOD.

This determination is based, in part, on the foregoing description which includes specific coordinates, heights, frequency(ies) and power. Any changes in coordinates, heights, and frequencies or use of greater power will void this determination. Any future construction or alteration, including increase to heights, power, or the addition of other transmitters, requires separate notice to the FAA.

This determination does include temporary construction equipment such as cranes, derricks, etc., which may be used during actual construction of the structure. However, this equipment shall not exceed the overall heights as indicated above. Equipment which has a height greater than the studied structure requires separate notice to the FAA.

This determination concerns the effect of this structure on the safe and efficient use of navigable airspace by aircraft and does not relieve the sponsor of compliance responsibilities relating to any law, ordinance, or regulation of any Federal, State, or local government body.

Any failure or malfunction that lasts more than thirty (30) minutes and affects a top light or flashing obstruction light, regardless of its position, should be reported immediately to (877) 487-6867 so a Notice to Airmen (NOTAM) can be issued. As soon as the normal operation is restored, notify the same number.

If we can be of further assistance, please contact our office at (718) 553-4542. On any future correspondence concerning this matter, please refer to Aeronautical Study Number 2011-AEA-3957-OE.

Signature Control No: 151570362-152835207

Katie Venticinque
Specialist

(DNE)

The Town of Cheektowaga



Office of Building and Plumbing Inspections
3301 Broadway
Cheektowaga, NY 14227
(716) 686-3490

To: Supervisor Mary F. Holtz
Honorable Town Board Members
Alice Magierski, Town Clerk
Kevin Schenk, Town Attorney

From: Thomas Adamczak
Supervising Code Enforcement Officer
Date: November 3, 2011

The following is a summary of the proposals that have been reviewed by the Town Environmental Advisory Committee at a meeting on November 2, 2011 in the Town Hall Council Office Conference Room. Conservation Advisory Council absent.

ITEM I 100 Affinity Lane – Proposed 4,874 sf concession building

Applicant: Collegiate Village

The proposal is to construct a concession building next to and connected to the existing student center. The services offered are food oriented.

The applicant has included suggestions of the Town Engineer including better pedestrian access and drainage system improvements. Final drainage and sanitary systems have yet to be finalized by the Town Engineer.

The committee would recommend that a negative declaration be issued for this project.

ITEM II 866 Aero Drive – Proposed 28,631 sf warehouse/office

Applicant: Krog Corp.

The site was previously reviewed for a 200,000 sf warehouse and at that time the US Army Corps of Engineers (USACE) had issued a letter of non jurisdiction which was later rescinded. As a result there was approximately 3 acres to be developed with the balance wetlands. The new project is intended to be within the 3 acres and therefore the USACE has no objection.

The Planning Board has tabled this action for a lack of information.

The Town Engineer critiqued the revised plan citing a lack of topography information, the locating of a drainage pipe under the building, and placing a sidewalk at the edge of the Aero Drive pavement. The design professional needs to review the plan.

**ITEM III 2480 & 2490 – 2550 Walden Avenue – Rezoning M1 to CM, demolish
3 buildings (184,500 sf) and construct retail (185,000 sf)**

Applicant: Benderson Properties, Inc.

As mentioned in previous minutes, the project will be “segmented” into the concept of rezoning and then the actual site plan presented when a tenant is found for the site. The committee would recommend a negative declaration for the rezoning.

**ITEM IV 5100 Genesee Street – Proposed rezoning from MS to CM and
construction of a 7,515 sf retail building**

Applicant: Optima Design & Engineering, PLLC

The owner has filed to rezone rather than appear before the Zoning Board of Appeals for a use variance. The site plan was revised by moving the building parallel with Genesee Street and by moving the dumpsters.

The Planning Board has recommended approval, the ECDEP and NYSDOT had no concerns.

The committee would recommend a public hearing be scheduled to keep the project moving.

**ITEM V 4243 Genesee Street – Site plan for a 4 story/119 room hotel
(Townplace Suites)**

Applicant: Benderson Development Co.,LLC

The applicant previously had approval for 3 hotels, 2 of which are completed. The final tenant has been signed and therefore the final site plan for the hotel has been submitted. There has been FAA approval for the height and location.

The committee would recommend a negative declaration be issued for the project site plan.

**ITEM VI 51 Anderson Road – Proposed rezoning from M@ to MS to convert an
existing warehouse to an auto/truck repair facility with towing services**

Applicant: Lapaglia Truck & Auto Repair

This is an incomplete submission. The application lacks a site plan showing parking for customer and employee vehicles.

Committee members noted that the present facility on Broadway and Ludwig was never improved as promised by the applicant many years ago.

Tabled for submission of all necessary documents.

**THE NEXT MEETING OF THE EAC WILL BE HELD
WEDNESDAY NOVEMBER 30th AT 10:00 A. M. IN THE COUNCIL
CONFERENCE ROOM**

All rights reserved. Reuse of these documents without the expressed written permission of Carmina Wood Morris PC is prohibited. WARNING: It is violation of article 145 sections 7209N and 7301 of the New York State education law for any person, unless acting under the direction of a registered architect, licensed engineer or land surveyor to alter this drawing. If altered such R.A., P.E. or L.L.S. shall affix his or her seal, signature, the date, the notation "altered by" and a specific description of the alteration.

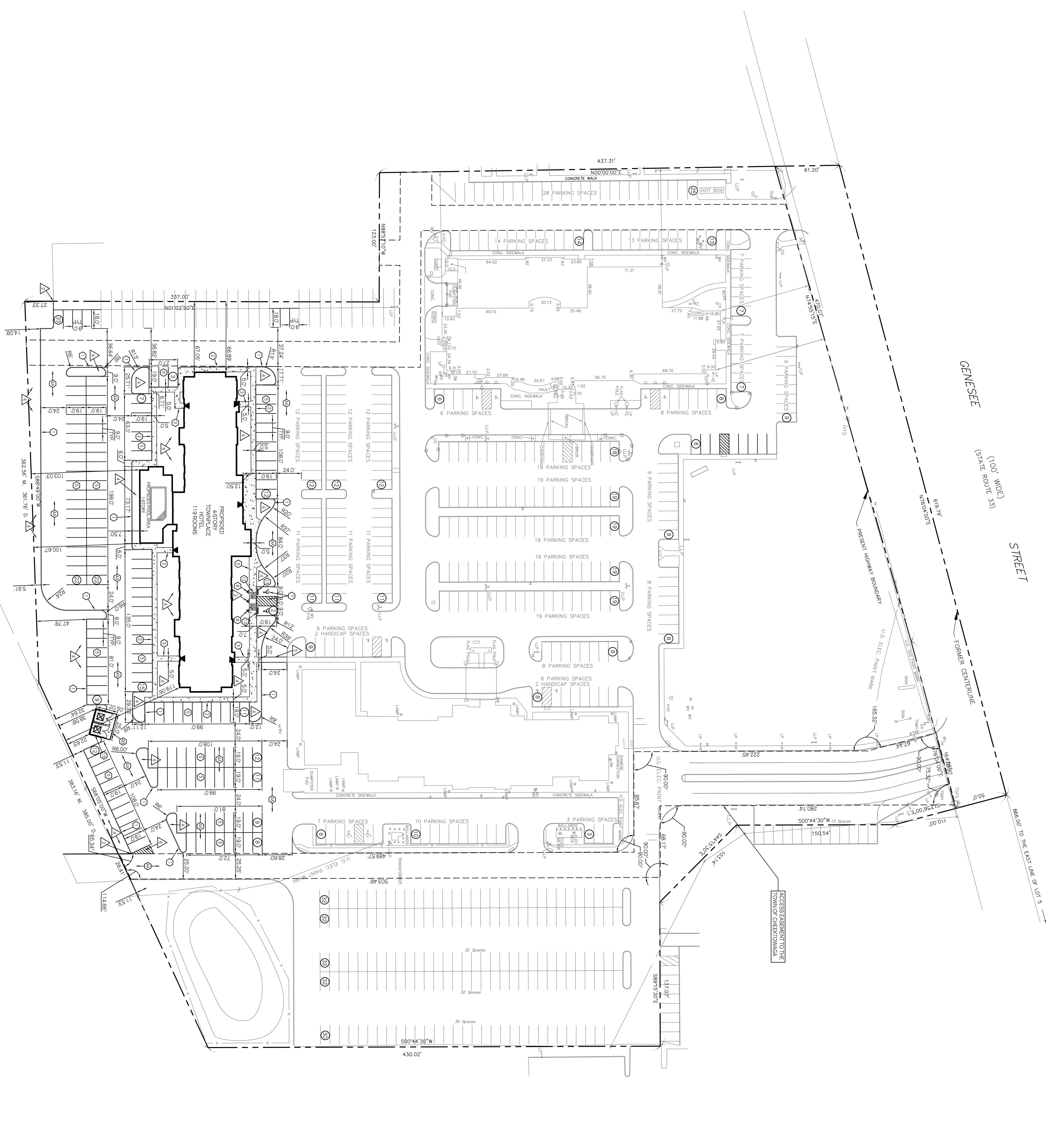

SITE PLAN
SCALE: 1"=40'

SITE DATA	
SITE AREA = 12.899 ACRES	
ZONED (GENERAL COMMERCIAL DISTRICT)	
BUILDING AREA EXISTING 139 ROOM 5 STORY HOTEL, 140 ROOM 5 STORY HOTEL	
PROPOSED 119 ROOM 4 STORY HOTEL	
STRIPBACK BUILDING	REQUIRED 87.25 FT MIN. (EX)
STRIPBACK BUILDING NON-RESIDENTIAL	50 FT
REAR BUILDING NON-RESIDENTIAL	68.89 FT MIN.
REAR BUILDING NON-RESIDENTIAL	10 FT
REAR BUILDING NON-RESIDENTIAL	100.07 FT MIN.
STRIPBACKS PARKING	25 FT
FRONT	25 FT
SIDE ABUTTING NON-RESIDENTIAL	10 FT
REAR ABUTTING NON-RESIDENTIAL	10 FT
GENESEEE	25 FT
TOTAL SITE IS PERCENT:	1.90 AC
INTERIOR OF PARKING AREAS PERCENT:	0.80 AC
PARKING	496
SEE CALCULATION BELOW	686

PARKING CALCULATIONS	
MARROTT COURTYARD HOTEL:	
139 ROOMS, 1 SPACE PER ROOM	139
MEETING ROOMS, 15 SPACES PER PERSON	27
MEETING ROOM, 15 SPACES PER PERSON	27
2 SPACES PER 5 SEATS	
FARMFIELD MARROTT:	
140 ROOMS, 1 SPACE PER ROOM	140
MEETING ROOMS, 15 SPACES PER PERSON	N/A
BREAKFAST AREA (HOTEL ONLY)	N/A
PROPOSED TOWNPLACE	119
BREAKFAST AREA (HOTEL ONLY)	N/A
TOTAL SPACES REQUIRED	496
TOTAL SPACES PROVIDED	499

- NOTES**
1. ALL ROAD SHALL BE 3'0" UNLESS OTHERWISE NOTED.
 2. ALL DISTRIBUTION AREAS SHALL HAVE 4" MIN. OF TOPSOIL AND SEED.
 3. ALL DIMENSIONS FROM PROPERTY LINES SHALL BE MEASURED PERPENDICULAR TO THE PROPERTY LINE.
 4. CENTER ENTRANCE SIDEWALKS ON DOOR OPENINGS.
 5. BUILDING DIMENSIONS ARE APPROXIMATE REFER TO ARCHITECTURAL DRAWINGS FOR EXACT DIMENSIONS.

- GENERAL NOTES**
1. INSTALL ALL MATERIALS TO MANUFACTURER'S RECOMMENDATIONS AND BEST STANDARDS.
 2. SUBSTITUTIONS SHALL BE MADE ONLY WITH OWNER'S APPROVAL AND BE OF EQUIVALENT QUALITY TO WHAT IS SPECIFIED.
 3. WORK SHALL BE COMPLETED IN STRICT ACCORDANCE WITH ALL LOCAL CODES AND OSHA.
 4. VERIFY ALL EXISTING CONDITIONS AND DIMENSIONS AT THE SITE. NOTIFY OWNER, ENGINEER OR DISCREPANCIES IN CONDITIONS SHOWN ON DRAWINGS PRIOR TO PROCEEDING WITH THE WORK.
 5. CONTRACTOR SHALL BE RESPONSIBLE FOR PROTECTING ALL EXISTING STRUCTURES AND UTILITIES.
 6. CONTRACTOR SHALL KEEP JOB FREE OF DEBRIS AND MAKE FINAL CLEANUP TO OWNER'S SATISFACTION.
 7. CONTRACTOR SHALL MAINTAIN ACCESS TO ALL UTILITIES PRIOR TO CONSTRUCTION.
 8. CONTRACTOR SHALL OBTAIN AND PAY FOR ALL REQUIRED PERMITS NECESSARY TO PERFORM THE WORK.

- DETAIL LEGEND**
- 1. 3" CONCRETE CURB
 - 2. INTERIOR CURB / SIDEWALK
 - 3. CONCRETE SIDEWALK
 - 4. STAMPEDED ASPHALT
 - 5. STRIPBACK CURB
 - 6. STRIPBACK CURB (ON GRADE)
 - 7. STRIPBACK CURB (OFF GRADE)
 - 8. HANDICAPPED PARKING MARKINGS
 - 9. SIDEWALK PARKING MARKINGS
 - 10. SIDEWALK CURB MARKINGS
 - 11. SIDEWALK PARKING MARKINGS
 - 12. SIDEWALK PARKING MARKINGS
 - 13. SIDEWALK PARKING MARKINGS
 - 14. SIDEWALK PARKING MARKINGS
 - 15. SIDEWALK PARKING MARKINGS
 - 16. SIDEWALK PARKING MARKINGS
 - 17. SIDEWALK PARKING MARKINGS
 - 18. SIDEWALK PARKING MARKINGS
 - 19. SIDEWALK PARKING MARKINGS
 - 20. SIDEWALK PARKING MARKINGS
 - 21. SIDEWALK PARKING MARKINGS
 - 22. SIDEWALK PARKING MARKINGS
 - 23. SIDEWALK PARKING MARKINGS
 - 24. SIDEWALK PARKING MARKINGS
 - 25. SIDEWALK PARKING MARKINGS
 - 26. SIDEWALK PARKING MARKINGS
 - 27. SIDEWALK PARKING MARKINGS
 - 28. SIDEWALK PARKING MARKINGS
 - 29. SIDEWALK PARKING MARKINGS
 - 30. SIDEWALK PARKING MARKINGS
 - 31. SIDEWALK PARKING MARKINGS
 - 32. SIDEWALK PARKING MARKINGS
 - 33. SIDEWALK PARKING MARKINGS
 - 34. SIDEWALK PARKING MARKINGS
 - 35. SIDEWALK PARKING MARKINGS
 - 36. SIDEWALK PARKING MARKINGS
 - 37. SIDEWALK PARKING MARKINGS
 - 38. SIDEWALK PARKING MARKINGS
 - 39. SIDEWALK PARKING MARKINGS
 - 40. SIDEWALK PARKING MARKINGS
 - 41. SIDEWALK PARKING MARKINGS
 - 42. SIDEWALK PARKING MARKINGS
 - 43. SIDEWALK PARKING MARKINGS
 - 44. SIDEWALK PARKING MARKINGS
 - 45. SIDEWALK PARKING MARKINGS
 - 46. SIDEWALK PARKING MARKINGS
 - 47. SIDEWALK PARKING MARKINGS
 - 48. SIDEWALK PARKING MARKINGS
 - 49. SIDEWALK PARKING MARKINGS
 - 50. SIDEWALK PARKING MARKINGS
 - 51. SIDEWALK PARKING MARKINGS
 - 52. SIDEWALK PARKING MARKINGS
 - 53. SIDEWALK PARKING MARKINGS
 - 54. SIDEWALK PARKING MARKINGS
 - 55. SIDEWALK PARKING MARKINGS
 - 56. SIDEWALK PARKING MARKINGS
 - 57. SIDEWALK PARKING MARKINGS
 - 58. SIDEWALK PARKING MARKINGS
 - 59. SIDEWALK PARKING MARKINGS
 - 60. SIDEWALK PARKING MARKINGS
 - 61. SIDEWALK PARKING MARKINGS
 - 62. SIDEWALK PARKING MARKINGS
 - 63. SIDEWALK PARKING MARKINGS
 - 64. SIDEWALK PARKING MARKINGS
 - 65. SIDEWALK PARKING MARKINGS
 - 66. SIDEWALK PARKING MARKINGS
 - 67. SIDEWALK PARKING MARKINGS
 - 68. SIDEWALK PARKING MARKINGS
 - 69. SIDEWALK PARKING MARKINGS
 - 70. SIDEWALK PARKING MARKINGS
 - 71. SIDEWALK PARKING MARKINGS
 - 72. SIDEWALK PARKING MARKINGS
 - 73. SIDEWALK PARKING MARKINGS
 - 74. SIDEWALK PARKING MARKINGS
 - 75. SIDEWALK PARKING MARKINGS
 - 76. SIDEWALK PARKING MARKINGS
 - 77. SIDEWALK PARKING MARKINGS
 - 78. SIDEWALK PARKING MARKINGS
 - 79. SIDEWALK PARKING MARKINGS
 - 80. SIDEWALK PARKING MARKINGS
 - 81. SIDEWALK PARKING MARKINGS
 - 82. SIDEWALK PARKING MARKINGS
 - 83. SIDEWALK PARKING MARKINGS
 - 84. SIDEWALK PARKING MARKINGS
 - 85. SIDEWALK PARKING MARKINGS
 - 86. SIDEWALK PARKING MARKINGS
 - 87. SIDEWALK PARKING MARKINGS
 - 88. SIDEWALK PARKING MARKINGS
 - 89. SIDEWALK PARKING MARKINGS
 - 90. SIDEWALK PARKING MARKINGS
 - 91. SIDEWALK PARKING MARKINGS
 - 92. SIDEWALK PARKING MARKINGS
 - 93. SIDEWALK PARKING MARKINGS
 - 94. SIDEWALK PARKING MARKINGS
 - 95. SIDEWALK PARKING MARKINGS
 - 96. SIDEWALK PARKING MARKINGS
 - 97. SIDEWALK PARKING MARKINGS
 - 98. SIDEWALK PARKING MARKINGS
 - 99. SIDEWALK PARKING MARKINGS
 - 100. SIDEWALK PARKING MARKINGS

- NOTE LEGEND**
- 1. 3" CONCRETE CURB
 - 2. INTERIOR CURB / SIDEWALK
 - 3. CONCRETE SIDEWALK
 - 4. STAMPEDED ASPHALT
 - 5. STRIPBACK CURB
 - 6. STRIPBACK CURB (ON GRADE)
 - 7. STRIPBACK CURB (OFF GRADE)
 - 8. HANDICAPPED PARKING MARKINGS
 - 9. SIDEWALK PARKING MARKINGS
 - 10. SIDEWALK CURB MARKINGS
 - 11. SIDEWALK PARKING MARKINGS
 - 12. SIDEWALK PARKING MARKINGS
 - 13. SIDEWALK PARKING MARKINGS
 - 14. SIDEWALK PARKING MARKINGS
 - 15. SIDEWALK PARKING MARKINGS
 - 16. SIDEWALK PARKING MARKINGS
 - 17. SIDEWALK PARKING MARKINGS
 - 18. SIDEWALK PARKING MARKINGS
 - 19. SIDEWALK PARKING MARKINGS
 - 20. SIDEWALK PARKING MARKINGS
 - 21. SIDEWALK PARKING MARKINGS
 - 22. SIDEWALK PARKING MARKINGS
 - 23. SIDEWALK PARKING MARKINGS
 - 24. SIDEWALK PARKING MARKINGS
 - 25. SIDEWALK PARKING MARKINGS
 - 26. SIDEWALK PARKING MARKINGS
 - 27. SIDEWALK PARKING MARKINGS
 - 28. SIDEWALK PARKING MARKINGS
 - 29. SIDEWALK PARKING MARKINGS
 - 30. SIDEWALK PARKING MARKINGS
 - 31. SIDEWALK PARKING MARKINGS
 - 32. SIDEWALK PARKING MARKINGS
 - 33. SIDEWALK PARKING MARKINGS
 - 34. SIDEWALK PARKING MARKINGS
 - 35. SIDEWALK PARKING MARKINGS
 - 36. SIDEWALK PARKING MARKINGS
 - 37. SIDEWALK PARKING MARKINGS
 - 38. SIDEWALK PARKING MARKINGS
 - 39. SIDEWALK PARKING MARKINGS
 - 40. SIDEWALK PARKING MARKINGS
 - 41. SIDEWALK PARKING MARKINGS
 - 42. SIDEWALK PARKING MARKINGS
 - 43. SIDEWALK PARKING MARKINGS
 - 44. SIDEWALK PARKING MARKINGS
 - 45. SIDEWALK PARKING MARKINGS
 - 46. SIDEWALK PARKING MARKINGS
 - 47. SIDEWALK PARKING MARKINGS
 - 48. SIDEWALK PARKING MARKINGS
 - 49. SIDEWALK PARKING MARKINGS
 - 50. SIDEWALK PARKING MARKINGS
 - 51. SIDEWALK PARKING MARKINGS
 - 52. SIDEWALK PARKING MARKINGS
 - 53. SIDEWALK PARKING MARKINGS
 - 54. SIDEWALK PARKING MARKINGS
 - 55. SIDEWALK PARKING MARKINGS
 - 56. SIDEWALK PARKING MARKINGS
 - 57. SIDEWALK PARKING MARKINGS
 - 58. SIDEWALK PARKING MARKINGS
 - 59. SIDEWALK PARKING MARKINGS
 - 60. SIDEWALK PARKING MARKINGS
 - 61. SIDEWALK PARKING MARKINGS
 - 62. SIDEWALK PARKING MARKINGS
 - 63. SIDEWALK PARKING MARKINGS
 - 64. SIDEWALK PARKING MARKINGS
 - 65. SIDEWALK PARKING MARKINGS
 - 66. SIDEWALK PARKING MARKINGS
 - 67. SIDEWALK PARKING MARKINGS
 - 68. SIDEWALK PARKING MARKINGS
 - 69. SIDEWALK PARKING MARKINGS
 - 70. SIDEWALK PARKING MARKINGS
 - 71. SIDEWALK PARKING MARKINGS
 - 72. SIDEWALK PARKING MARKINGS
 - 73. SIDEWALK PARKING MARKINGS
 - 74. SIDEWALK PARKING MARKINGS
 - 75. SIDEWALK PARKING MARKINGS
 - 76. SIDEWALK PARKING MARKINGS
 - 77. SIDEWALK PARKING MARKINGS
 - 78. SIDEWALK PARKING MARKINGS
 - 79. SIDEWALK PARKING MARKINGS
 - 80. SIDEWALK PARKING MARKINGS
 - 81. SIDEWALK PARKING MARKINGS
 - 82. SIDEWALK PARKING MARKINGS
 - 83. SIDEWALK PARKING MARKINGS
 - 84. SIDEWALK PARKING MARKINGS
 - 85. SIDEWALK PARKING MARKINGS
 - 86. SIDEWALK PARKING MARKINGS
 - 87. SIDEWALK PARKING MARKINGS
 - 88. SIDEWALK PARKING MARKINGS
 - 89. SIDEWALK PARKING MARKINGS
 - 90. SIDEWALK PARKING MARKINGS
 - 91. SIDEWALK PARKING MARKINGS
 - 92. SIDEWALK PARKING MARKINGS
 - 93. SIDEWALK PARKING MARKINGS
 - 94. SIDEWALK PARKING MARKINGS
 - 95. SIDEWALK PARKING MARKINGS
 - 96. SIDEWALK PARKING MARKINGS
 - 97. SIDEWALK PARKING MARKINGS
 - 98. SIDEWALK PARKING MARKINGS
 - 99. SIDEWALK PARKING MARKINGS
 - 100. SIDEWALK PARKING MARKINGS

- SITE LEGEND**
- PROPOSED LINE
 - PROPOSED CURB
 - PROPOSED SIDEWALK / CONCRETE PAD
 - NUMBER OF PARKING SPACES
 - PROPOSED SIDEWALK
 - PROPOSED LIGHT POLE W/ DOUBLE FUTURE
 - PROPOSED LIGHT POLE W/ SINGLE FUTURE
 - PROPOSED WALL, RETAINED FUTURE

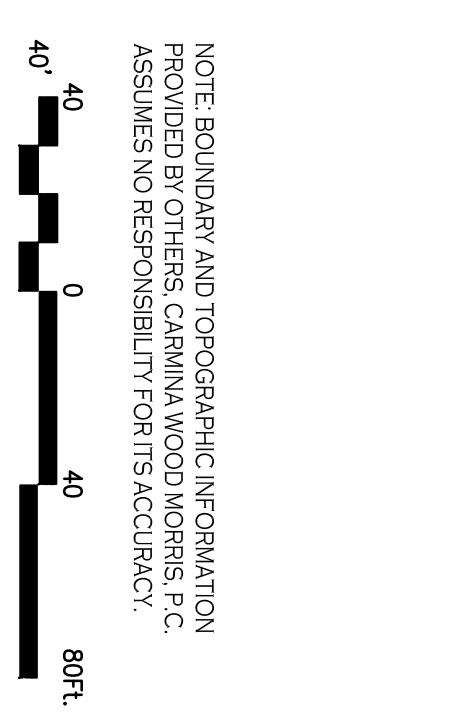

NOTE: SOILS, WATER AND TOPOGRAPHIC INFORMATION PROVIDED BY OTHERS. CARMINA WOOD MORRIS, P.C. ASSUMES NO RESPONSIBILITY FOR ITS ACCURACY.

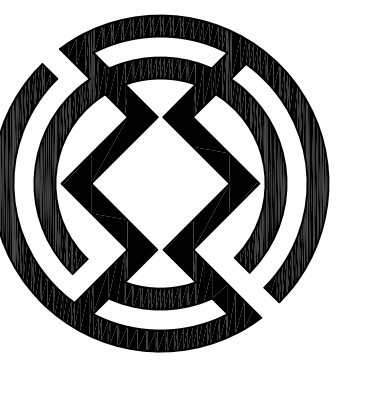

Carmina Wood Morris
467 Main Street, Suite 1000
Cheektowaga, NY 14124
P: 716.424.2185
F: 716.424.2858

REVISONS:		
No.	Description	Date

PROJECT NAME:
New Construction
Proposed Hotel Complex
4243 Genesee Street
Cheektowaga, New York
BDC Property #3829

DRAWING NO.:
C-4

Scale:
As Noted

Project no.: 04.126



TOWN OF CHEEKTOWAGA

ZONING BOARD OF APPEALS DECISION

Whereas, **Benderson Development Co., LLC/James a Boglioli** has made application for a(n) **Area Variance**, under

ARTICLE(S): III **SECTION(S):** 260-32

of the zoning law for property located at:

4243 Genesee Street

The applicant's proposed hotel will be (56) fifty six feet in height, whereas, the Zoning Law limits the heights of buildings within (200) feet of the Buffalo Niagara International Airport (BNIA) to (15) fifteen feet maximum.

Whereas, a public hearing was held on after proper notice,

Whereas, this Board, after reviewing the application, and conducting a public hearing and after due deliberation and vote of the Board,

Be it resolved, by virtue of the power vested in the Zoning Board of Appeals, this **Area Variance** is hereby **{MotionResultName}**.

This area variance is granted as requested on the following conditions:

1. Applicant obtains approval from the Federal Aviation Administration (FAA) for the construction of this hotel as planned; and
2. Applicant meets all conditions of all other town committees and boards, including, but not limited to the Town Planning Board.

In reaching this decision the Board balanced the benefit to the applicant against the detriment to the health, safety and welfare of the neighborhood community. In conducting this balancing test the Board considered the following five factors: (a) whether an undesirable change will be produced in the character of the neighborhood or a detriment to nearby properties will be created by the granting of the area variance; (b) whether the benefit sought by the applicant can be achieved by some method feasible for the applicant to pursue, other than an area variance; (c) whether the requested area variance is substantial; (d) whether the proposed variance will have an adverse effect or impact on the physical or environmental conditions in the neighborhood or district; and (e) whether the alleged difficulty was self-created, which consideration shall be relevant to the decision of the board of appeals, but shall not preclude the granting of the area variance.

The application and testimony presented indicate the proposed hotel will be four stories tall, not

to exceed 56 feet in height. It is located in area very near the airport that is highly commercial and where many other similar hotels are located. There are two other hotels located on this particular property. This additional height is needed to make the hotel economically feasible. According to Applicant, the Town Planning Board and Traffic Safety Committee approved and recommended this project as planned. No one appeared in opposition to this application.

The granting of this application will not create an undesirable change in the character of the neighborhood, nor are the requested area variances substantial. There has been an adequate showing that strict compliance with the zoning ordinance will result in practical difficulties to the applicant and that granting this variance will not create a substantial detriment to adjoining property owners.

Dated: November 10, 2011

{MotionBlockText}

*Note – Construction cannot begin until a building permit is applied for and approved. This decision will be automatically revoked unless a building permit is obtained within six (6) months of the date hereof and unless construction commences within one (1) year of the date hereof.

NOTES

- FOR REFERENCE INFORMATION SEE TOPOGRAPHIC BOUNDARY SURVEY PREPARED BY MILLARD, MCKAY, & DELLES DATED NOVEMBER 26, 2006 AND IDENTIFIED AS SBL NO. 90.08.7-775.
- ALL CONSTRUCTION SHALL CONFORM TO TOWN OF CHEEKTOWAGA STANDARDS AND NEW YORK STATE CODE REQUIREMENTS, AS WELL AS THE LATEST A.S.C. A.C.I. O.S.H.A., AND A.S.T.M. STANDARDS, WHERE COMES OVERLAP WITH CONSTRUCTION SHALL COMPLY WITH THE MORE TRANSPARENT CODE.
- WHERE A SPECIFIC MANUFACTURER'S PRODUCT IS CALLED OUT ON THIS SHEET OR ANY OTHER PLAN IN THIS SET OF DRAWINGS, THE CONTRACTOR MUST COMPLY WITH THE MANUFACTURER'S LATEST PRINTED INSTRUCTIONS AND RECOMMENDATIONS FOR INSTALLATION.
- DURING CONSTRUCTION THE CONTRACTOR SHALL ERECT AND MAINTAIN AS NECESSARY ALL TEMPORARY BARRICADES, SAFETY FENCING, CAUTION LIGHTS, OR SIGNAGE TO PROTECT THE WORK ACTIVITY AND TO ENSURE PUBLIC SAFETY. LAUER-MANGUSO & ASSOC. IS NOT RESPONSIBLE FOR ANY INJURIES TO WORKERS OR PEDESTRIANS AS RESULT OF EXCAVATION OR CONSTRUCTION ACTIVITIES.
- ALL TRAFFIC CONTROL AND WARNING SIGNS SHALL CONFORM TO N.Y.S.D.O.T. MANUAL OF UNIFORM TRAFFIC CONTROL DEVICES.
- THE CONTRACTOR SHALL MAINTAIN ACCESSIBLE PASSAGEWAYS FOR TRAFFIC AND PEDESTRIANS TO EXISTING BUSINESSES WHICH WILL REMAIN IN OPERATION THROUGHOUT THE DURATION OF THE CONSTRUCTION.
- ANY CAST-IN-PLACE CONCRETE SHALL CONFORM TO N.Y.S.D.O.T. STANDARD SPECIFICATIONS (SECTION 501) USE STRUTTING, FORMWORK, REINFORCING BARS, JOINTS, AND ALL OTHER GENERAL PURPOSE CONCRETE PAVEMENT ON SITE. CEMENT USED TO PRODUCE CONCRETE SHALL CONFORM WITH BOTH ACI 318 AND ASTM C1157.
- ALL CONCRETE CURBS, SIDEWALKS, APRONS, AND PADS SHALL BE CURED BY SPRAYING ON A CURING COMPOUND CONFORMING TO A.S.T.M. C309.
- THE CONTRACTOR SHALL VERIFY EXISTING CONDITIONS IN THE FIELD PRIOR TO THE START OF WORK. ANY DISCREPANCIES BETWEEN REAL LIFE CONDITIONS AND THIS SET OF SITE PLAN DRAWINGS SHALL BE BROUGHT TO THE ATTENTION OF LAUER-MANGUSO & ASSOC. IMMEDIATELY FOR FURTHER INSTRUCTIONS. FAILURE TO NOTIFY LAUER-MANGUSO CONSTITUTES THE CONTRACTOR'S ACCEPTANCE OF ALL THE CONDITIONS SHOWN ON THIS SET OF SITE PLANS.
- ANY DEVIATION FROM ANY PLANS IN THIS DRAWING SET SHALL REQUIRE APPROVAL OF LAUER-MANGUSO & ASSOC. AND THE TOWN OF CHEEKTOWAGA PLANNING AND ENGINEERING DEPARTMENTS, AS WELL AS THE APPROPRIATE UTILITY COMPANIES AND SERVICE PROVIDERS.
- ALL CONSTRUCTION OR EXCAVATION ACTIVITIES AND UTILITY INSTALLATIONS SHALL STRICTLY COMPLY WITH THE LATEST SAFETY STANDARDS AND REGULATIONS SET FORTH BY O.S.H.A., THE NEW YORK STATE HIGH VOLTAGE PROXIMITY ACT, AND NEW YORK STATE INDUSTRIAL CODE RULE 53.
- THE CONTRACTOR SHALL MAINTAIN INSURANCE THAT SHALL PROTECT HIM/HIMSELF FROM ANY LIABILITY UNDER WORKERS COMPENSATION ACTS AND OTHER EMPLOYEE BENEFIT ACTS IN COMPLIANCE WITH THE LAWS OF NEW YORK STATE, AND FROM LIABILITY FOR PROPERTY DAMAGES, BODILY INJURY, OR DEATH.
- THE CONTRACTOR SHALL BE RESPONSIBLE FOR PAYING ALL NECESSARY FEES AND OBTAINING ALL NECESSARY PERMITS PRIOR TO THE START OF CONSTRUCTION. CONTACT TOWN OF CHEEKTOWAGA ENGINEERING DEPARTMENT (897-7289) AND BUILDING DEPARTMENT (888-3567) FOR INSTRUCTIONS, PERMIT APPLICATIONS, AND FEES.

LEGEND

- EXISTING SIGN
- NEW SIGN
- EXISTING FENCE
- NEW FENCE
- EXISTING EDGE OF PAVEMENT
- NEW EDGE OF PAVEMENT
- EXISTING CURB
- NEW CURB (6")
- EXISTING LIGHT FIXTURE

SITE LAYOUT PLAN

SCALE: 1" = 30'-0"

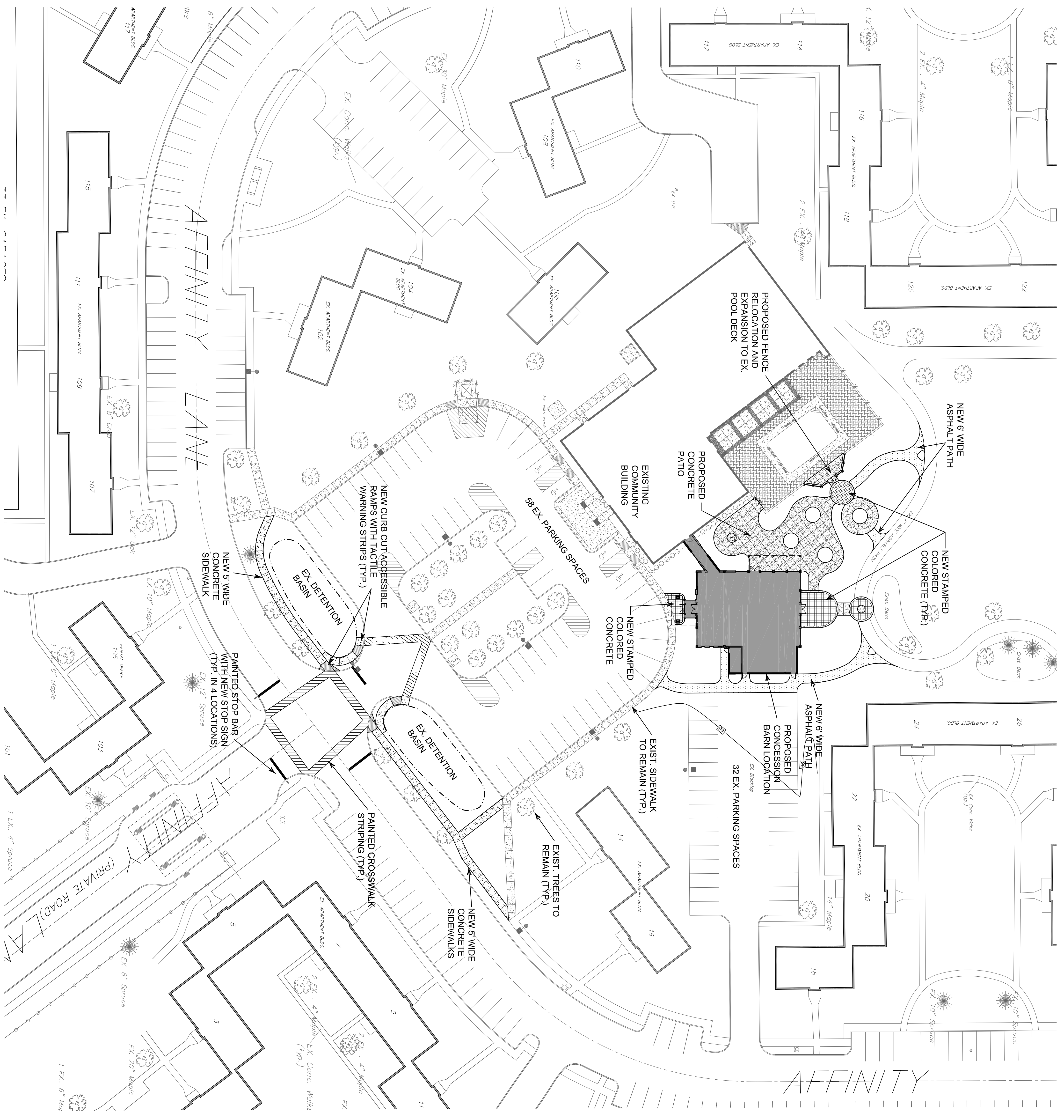
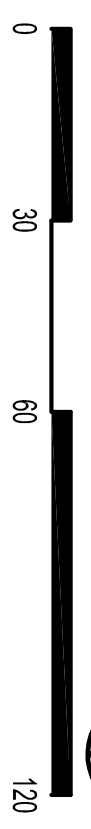

Attachment: site plan collegiate village (RES-2011-607 - Negative SEQR Declaration - 105 Affinity Lane)

CODE & SITE DATA

LIMIT OF WORK AREA = 34,000 SF (0.78 AC.)
 ZONED: RA (APARTMENT DISTRICT)

BUILDING SETBACK	REQUIRED	PROVIDED
FRONT	25'-0"	56'0"
SIDE	N.A.	N.A.
REAR	N.A.	N.A.

PAVEMENT SETBACK	REQUIRED	PROVIDED
FRONT	N.A.	N.A.
SIDE	N.A.	N.A.
REAR	N.A.	N.A.

LANDSCAPE	REQUIRED	PROVIDED
TOTAL PARCEL	15%	75% +/-
SITE	15%	88%

PARKING	REQUIRED	PROVIDED
EXISTING	64 SPACES	90 SPACES
PROPOSED	0 SPACES ***	0 SPACES ***
HANDICAP	3 SPACES	4 SPACES

*** (WITHIN LIMIT OF WORK AREA ONLY)

THE CONTRACTOR SHALL CONTACT LAUER-MANGUSO & ASSOC. BEFORE EXCAVATION & CONSTRUCTION TO ENSURE HE/SHE HAS THE FINAL SET OF DESIGN DOCUMENTS AS ISSUED FOR IT HAS BEEN ISSUED. SUBSEQUENT UPDATES OF THE PLAN BY LAUER-MANGUSO & ASSOC. DOES NOT AFFORD ANY TRANSFER OF THE RIGHT TO RECEIVE SAID UPDATES, BUT PLACES THE RESPONSIBILITY TO THE CONTRACTOR AS THESE MAY DIFFER FROM PREVIOUS PLANS ISSUED FOR PERMIT OR BID.

No.	Description	Date
1	ISSUED FOR DEVELOPMENT REVIEW	10-3-11

REVISIONS

COLLEGIATE VILLAGE CONCESSION BARN
 AFFINITY LANE, CHEEKTOWAGA, NY
 AFFINITY PARTNERS
 105 AFFINITY LANE, BUFFALO, NEW YORK 14215

SITE LAYOUT PLAN

LAUER-MANGUSO & ASSOCIATES ARCHITECTS
 4080 Ridge Lea Road
 Buffalo, N.Y., 14228
 (716) 837-0893

9/21/11 Drawing No. **C-1.0**
 Drawn By: RUB
 Checked By: MCT
 Job Number: 105049804

DRAWING IS A MODERN OF SECTION 2209, SUBSECTION 2, OF THE NEW YORK STATE LAW FOR ANY PERSON, UNLESS INDICATED OTHERWISE, TO OBTAIN A COPY, PLEASE SPECIFICATIONS, OR REPORTS TO WHICH THE SEAL OF A LICENSED ARCHITECT OR PROFESSIONAL ENGINEER HAS BEEN APPLIED.

The Town of Cheektowaga

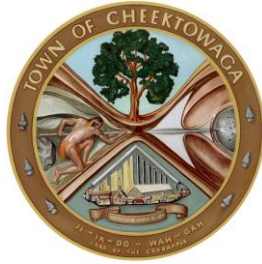

Office of Building and Plumbing Inspections
3301 Broadway
Cheektowaga, NY 14227
(716) 686-3490

To: Supervisor Mary F. Holtz
Honorable Town Board Members
Alice Magierski, Town Clerk
Kevin Schenk, Town Attorney

From: Thomas Adamczak
Supervising Code Enforcement Officer
Date: November 3, 2011

The following is a summary of the proposals that have been reviewed by the Town Environmental Advisory Committee at a meeting on November 2, 2011 in the Town Hall Council Office Conference Room. Conservation Advisory Council absent.

ITEM I 100 Affinity Lane – Proposed 4,874 sf concession building

Applicant: Collegiate Village

The proposal is to construct a concession building next to and connected to the existing student center. The services offered are food oriented.

The applicant has included suggestions of the Town Engineer including better pedestrian access and drainage system improvements. Final drainage and sanitary systems have yet to be finalized by the Town Engineer.

The committee would recommend that a negative declaration be issued for this project.

ITEM II 866 Aero Drive – Proposed 28,631 sf warehouse/office

Applicant: Krog Corp.

The site was previously reviewed for a 200,000 sf warehouse and at that time the US Army Corps of Engineers (USACE) had issued a letter of non jurisdiction which was later rescinded. As a result there was approximately 3 acres to be developed with the balance wetlands. The new project is intended to be within the 3 acres and therefore the USACE has no objection.

The Planning Board has tabled this action for a lack of information.

The Town Engineer critiqued the revised plan citing a lack of topography information, the locating of a drainage pipe under the building, and placing a sidewalk at the edge of the Aero Drive pavement. The design professional needs to review the plan.

**ITEM III 2480 & 2490 – 2550 Walden Avenue – Rezoning M1 to CM, demolish
3 buildings (184,500 sf) and construct retail (185,000 sf)**

Applicant: Benderson Properties, Inc.

As mentioned in previous minutes, the project will be “segmented” into the concept of rezoning and then the actual site plan presented when a tenant is found for the site. The committee would recommend a negative declaration for the rezoning.

**ITEM IV 5100 Genesee Street – Proposed rezoning from MS to CM and
construction of a 7,515 sf retail building**

Applicant: Optima Design & Engineering, PLLC

The owner has filed to rezone rather than appear before the Zoning Board of Appeals for a use variance. The site plan was revised by moving the building parallel with Genesee Street and by moving the dumpsters.

The Planning Board has recommended approval, the ECDEP and NYSDOT had no concerns.

The committee would recommend a public hearing be scheduled to keep the project moving.

**ITEM V 4243 Genesee Street – Site plan for a 4 story/119 room hotel
(Townplace Suites)**

Applicant: Benderson Development Co.,LLC

The applicant previously had approval for 3 hotels, 2 of which are completed. The final tenant has been signed and therefore the final site plan for the hotel has been submitted. There has been FAA approval for the height and location.

The committee would recommend a negative declaration be issued for the project site plan.

**ITEM VI 51 Anderson Road – Proposed rezoning from M@ to MS to convert an
existing warehouse to an auto/truck repair facility with towing services**

Applicant: Lapaglia Truck & Auto Repair

This is an incomplete submission. The application lacks a site plan showing parking for customer and employee vehicles.

Committee members noted that the present facility on Broadway and Ludwig was never improved as promised by the applicant many years ago.

Tabled for submission of all necessary documents.



Town of Cheektowaga

Regular Meeting

~ Minutes ~

3301 Broadway
Cheektowaga, NY 14227
<http://www.town.cheektowaga.ny.us>

Alice Magierski
716-686-3400

Monday, December 5, 2011

6:45 PM

Council Chambers

I. Call to Order

6:45 PM Meeting called to order on December 5, 2011 at Council Chambers, 3301 Broadway St, Cheektowaga, NY.

Attendee Name	Organization	Title	Status	Arrived
Mary Holtz	Town of Cheektowaga	Supervisor	Present	
Patricia Jaworowicz	Town of Cheektowaga	Councilmember	Present	
Jeff Swiatek	Town of Cheektowaga	Councilmember	Present	
James Rogowski	Town of Cheektowaga	Councilmember	Present	
Richard Zydel	Town of Cheektowaga	Councilmember	Present	
Charles Markel	Town of Cheektowaga	Councilmember	Present	
Stanley Kaznowski	Town of Cheektowaga	Councilmember	Present	

2. Additional Attendees

Thomas Adamczak, Supervising Building and Plumbing Inspector
Jerry Gabryszak, Director of Community Development
Brian Krause, Director of Finance and Administration
William Pugh, Town Engineer
Kevin Schenk, Town Attorney
Kerry Switalski, Senior Services Director

II. Public Comment Period

III. Resolutions



1. RESOLUTION 2011-626

Transfer of Funds

Sponsored By: Supervisor Holtz, Councilmember Swiatek

BE IT RESOLVED, that the following transfer is hereby approved and made a part hereof;

General Fund

From:	100.7110.2201	Office Equipment	\$ 4,400.00
	100.7110.2304	Park Equipment	6,800.00
	100.7140.1654	PT Regular Basketball Salaries	100.00
	100.7140.1654	PT Regular Basketball Salaries	200.00
	100.7140.1654	PT Regular Basketball Salaries	2,000.00
	100.1640.2509	Cargo Van	17,250.00
To:	100.7110.4451	Maintenance Repair	\$11,200.00
	100.7140.1815	PT Regular Outdoor Basketball Salaries	100.00
	100.7310.1801	Camp Ji-ik-do-wah-gah Salaries	200.00
	100.7140.1639	PT Regular Hockey Salaries	2,000.00
	100.7140.4464	Pre-K Expense	2,000.00
	100.7140.4519	After School Programs	2,000.00
	100.7140.4601	Aid To Youth	1,750.00
	100.7310.2501	Equipment	8,000.00
	100.7310.4689	Youth Conservation Corps.	3,500.00

RESULT:	ADOPTED [UNANIMOUS]
MOVER:	Mary Holtz, Supervisor
SECONDER:	Jeff Swiatek, Councilmember
AYES:	Holtz, Jaworowicz, Swiatek, Rogowski, Zydel, Markel, Kaznowski



2. RESOLUTION 2011-627

Warrant

Sponsored By: Supervisor Holtz, Councilmember Swiatek

BE IT RESOLVED, that the following Vouchers & Warrants submitted to the Town of Cheektowaga prior to November 25, 2011 are hereby approved and made a part hereof;

General Fund	\$ 8,142,794.54
Risk Retention Fund	92,576.08
NYS Home Program	10,750.00
HUD Housing Rehabilitation Fund	18,145.77
Special Districts Fund	1,605,446.20
Highway Fund	1,292,225.66
Capital Fund	502,018.59
Trust & Agency	42,947.90
HUD CDBG Fund	56,987.50
Part Town Fund	326,640.44
NYS Affordable Housing	61,641.00
	<hr/>
	\$12,152,173.68

RESULT:	ADOPTED [UNANIMOUS]
MOVER:	Mary Holtz, Supervisor
SECONDER:	Jeff Swiatek, Councilmember
AYES:	Holtz, Jaworowicz, Swiatek, Rogowski, Zydel, Markel, Kaznowski



3. RESOLUTION 2011-628

Amend Change Order for Asbestos Survey for 24E Glenwood Court

Sponsored By: Councilmember Markel, Councilmember Kaznowski

WHEREAS, by resolution dated November 21, 2011 (Resolution 2011-601), this Town Board approved a change order for a bid awarded to 56 Services, Inc. for a pre-demolition asbestos survey, specifications and air monitoring services for the demolition of 24E Glenwood Court, and

WHEREAS, the amount of the change order specified in said resolution (\$2,925.00) was in error, NOW, THEREFORE, BE IT

RESOLVED, that the amount of the change order for the aforesaid project be and hereby is corrected to read \$975.00 rather than \$2,925.00.

RESULT:	ADOPTED [UNANIMOUS]
MOVER:	Charles Markel, Councilmember
SECONDER:	Stanley Kaznowski, Councilmember
AYES:	Holtz, Jaworowicz, Swiatek, Rogowski, Zydel, Markel, Kaznowski



4. RESOLUTION 2011-629

Correction in Change Order for Asbestos Survey for 27 Alpine Place

Sponsored By: Councilmember Markel, Councilmember Kaznowski

WHEREAS, by resolution dated November 21, 2011 (Resolution 2011-602), this Town Board approved a change order for a bid awarded to 56 Services, Inc. for a pre-demolition asbestos survey, specifications and air monitoring services for the demolition of 27 Alpine Place, and

WHEREAS, the amount of the change order specified in the first "RESOLVED" paragraph of said resolution (\$2,295.00) should have read \$2,925.00, NOW, THEREFORE, BE IT

RESOLVED, that the amount of the change order for the aforesaid project be and hereby is corrected to read \$2,925.00 rather than \$2,295.00.

RESULT:	ADOPTED [UNANIMOUS]
MOVER:	Charles Markel, Councilmember
SECONDER:	Stanley Kaznowski, Councilmember
AYES:	Holtz, Jaworowicz, Swiatek, Rogowski, Zydel, Markel, Kaznowski



5. RESOLUTION 2011-630

Negative SEQR Declaration- 5100 Genesee Street

Sponsored By: Councilmember Kaznowski, Councilmember Markel

WHEREAS, pursuant to the Environmental Impact Review Ordinance of the Town of Cheektowaga, the Environmental Advisory Committee ("EAC") reviews various applications for site plans, rezonings, special permits, etc. and renders its recommendation concerning the environmental significance of such application, AND

WHEREAS, the Town Board, pursuant to the Environmental Impact Review Ordinance of the Town of Cheektowaga, is designated the Lead Agency in most instances, AND

WHEREAS, since the Town Board is the Lead Agency, it must affirm, modify or reject any recommendations submitted to it by the Advisory Committee, AND

WHEREAS, an application was submitted by Optima Design & Engineering, PPLC for the rezoning of 5100 Genesee Street from MS- Motor Service to CM- General Commercial for the construction of a 7,515 square foot retail plaza, AND

WHEREAS, the Environmental Advisory Committee at its meetings held on November 30, 2011 recommended a determination of non-significance as shown on the attached memorandum dated November 30, 2011, AND

WHEREAS, the Town of Cheektowaga Planning Board recommended approval of the rezoning request and the site plan at their meetings of September 8, 2011 and November 10, 2011, respectively, AND

WHEREAS, this Town Board has reviewed the application submitted and the recommendations made by the Environmental Advisory Committee and the Planning Board NOW, THEREFORE, BE IT

RESOLVED, that this Town Board determines that the project will not have a significant effect on the environment and therefore issues a Negative Declaration for purposes of SEQRA, AND BE IT

FURTHER RESOLVED, the proposed site plan is found to be acceptable subject to :

1. The Town Engineer reviewing/approving the grading/drainage plan;
2. The curb line near the north east building corner be extended further west to protect the building exit;
3. The applicant obtain an area variance from the Cheektowaga Zoning Board of Appeals for the building setback near the north west building corner.

Attachments:

revised site plan (PDF)

RESULT:	ADOPTED [UNANIMOUS]
MOVER:	Stanley Kaznowski, Councilmember
SECONDER:	Charles Markel, Councilmember
AYES:	Holtz, Jaworowicz, Swiatek, Rogowski, Zydel, Markel, Kaznowski



6. RESOLUTION 2011-631

Negative SEQR Determination - 2480 and Part of 2490-2550 Walden

Sponsored By: Holtz, Markel, Kaznowski, Rogowski, Swiatek, Jaworowicz, Zydel

WHEREAS, the Town Board, pursuant to the Environmental Impact Review Ordinance of the Town of Cheektowaga and the NYS Environmental Quality Review Act (SEQRA) is designated the Lead Agency, AND

WHEREAS, an application was submitted by Benderson Development Co., LLC for the rezoning of 2480 and part of 2490-2550 Walden Avenue from M1- Light Manufacturing to CM-General Commercial, AND

WHEREAS, the Environmental Advisory Committee at its meetings held on November 2, 2011 recommended a determination of non-significance for the rezoning action , AND

WHEREAS, the Town of Cheektowaga Planning Board recommended approval of rezoning request at their meeting of January 13, 2011, AND

WHEREAS, the Town of Cheektowaga Traffic Safety Commission has reviewed the rezoning request and recommended its approval at their meeting of January 18, 2011, AND

WHEREAS, pursuant to the Environmental Impact Review Ordinance of the Town of Cheektowaga, the Environmental Advisory Committee ("EAC") reviews various applications for site plans, rezonings, special permits, etc. and renders its recommendation concerning the environmental significance of such application, AND

WHEREAS, this Town Board has reviewed the application submitted and the recommendations made by the Environmental Advisory Committee, the Planning Board and the Traffic Safety Commission NOW, THEREFORE, BE IT

RESOLVED, that this Town Board determines that the project will not have a significant effect on the environment and therefore issues a Negative Declaration for purposes of SEQRA, AND BE IT

FURTHER RESOLVED, this Board affirms its right to segment this SEQR determination from any future site plan approval action as stipulated in the attached notice of Determination of Non Significance; and reserves its right to establish a new SEQR review once a building user and/or tenant is identified by the applicant.

Attachments:

notice of determination (PDF)

RESULT: ADOPTED [UNANIMOUS]
MOVER: Mary Holtz, Supervisor
SECONDER: Charles Markel, Councilmember

AYES: Holtz, Jaworowicz, Swiatek, Rogowski, Zydel, Markel, Kaznowski



7. RESOLUTION 2011-632

Approval of Rezoning - 2480 & 2490-2550 Walden Avenue

Sponsored By: Markel, Kaznowski, Holtz, Swiatek, Jaworowicz, Rogowski, Zydel

WHEREAS, Benderson Development Company, LLC petitioned for a rezoning from M1-Light Manufacturing District to CM-General Commercial District for property owned by it and located at 2480 Walden Avenue and 2490-2550 Walden Avenue, Cheektowaga, New York, which property is described in the attached legal description, for commercial/retail/restaurant use, and

WHEREAS, a public hearing on such petition was held before this Town Board on the 20th day of June, 2011 at 6:30 P.M., after publication and service of the notices required by the provisions of the Code of the Town of Cheektowaga ("Zoning Law"), and the Town Law; and all interested parties were given an opportunity to be heard at such hearing, and

WHEREAS, the Cheektowaga Planning Board has reviewed such application and has recommended approval thereof, and

WHEREAS, this Town Board previously issued a Negative Declaration under SEQRA and the Town Environmental Impact Review Ordinance for this rezoning, NOW, THEREFORE, BE IT

RESOLVED, that the application of Benderson Development Company, LLC for the rezoning from M1-Light Manufacturing District to CM-General Commercial District of the property described in the attached legal description be and the same is hereby approved, subject to the following conditions:

- 1. The actual development or site plan must be submitted to this Town Board for approvals.

and BE IT FURTHER

RESOLVED, that the Zoning Map and Law of the Town Of Cheektowaga be amended in accordance with the above.

LEGAL DESCRIPTION

LEGAL DESCRIPTION OF LANDS TO BE REZONED

ALL THAT TRACT OR PARCEL OF LAND, situate in the Town of Cheektowaga, County of Erie and State of New York, being part of Lot No. 11, Township 11 and Range 7 of the Holland Land Company's Survey and being further bounded and described as follows:

BEGINNING at a point in the east line of Lot No. 11 distant 140 feet south of its intersection with the south line of Zoerb Avenue as laid out on a map filed in the Erie County Clerk's office under Map Cover No. 2146; Thence westerly, parallel with the south line of Zoerb Avenue, a distance of 757.89 feet to the True Point and Place of Beginning;

Thence southerly at an interior angle of 89°52'43", a distance of 580.99 feet to a point on the northerly line of said Walden Avenue;

Thence westerly along the northerly line of said Walden Avenue, a distance of 837.63 feet to a point in the west line of lands conveyed to Nathan Rovner by deed recorded in the Erie County Clerk's Office in Liber 5897 of Deeds at page 528;

Thence northerly along the west line of land so conveyed to Nathan Rovner, 986.51 feet to a point 140.0 feet southerly from the intersection of the said west line of Rovner's land with the south line of Zoerb Avenue as laid out on a map filed in the Erie County Clerk's office under Map Cover No. 2146;

Thence easterly, and parallel with the south line of said Zoerb Avenue 827.02 feet to the True point and place of beginning.

This parcel containing 759,351 Sq.Ft. or 17.432 Acres more or less.

RESULT:	ADOPTED [UNANIMOUS]
MOVER:	Charles Markel, Councilmember
SECONDER:	Stanley Kaznowski, Councilmember
AYES:	Holtz, Jaworowicz, Swiatek, Rogowski, Zydel, Markel, Kaznowski



8. RESOLUTION 2011-633

Approval of Rezoning - 5100 Genesee Street

Sponsored By: Councilmember Markel, Councilmember Kaznowski

WHEREAS, Christopher J. D'Angelo petitioned for a rezoning from MS-Motor Services District to CM-General Commercial District for property owned by Genesee Transit Holdings VII, LLC and located at 5100 Genesee Street, Cheektowaga, New York, which property is described in the attached legal description, for the construction of a 7,515 square foot retail plaza, and

WHEREAS, a public hearing on such petition was held before this Town Board on the 21st day of November, 2011 at 6:30 P.M., after publication and service of the notices required by the provisions of the Code of the Town of Cheektowaga ("Zoning Law"), and the Town Law; and all interested parties were given an opportunity to be heard at such hearing, and

WHEREAS, the Cheektowaga Planning Board has reviewed such application and has recommended approval thereof, and

WHEREAS, this Town Board previously issued a Negative Declaration under SEQRA and the Town Environmental Impact Review Ordinance for this rezoning, NOW, THEREFORE, BE IT

RESOLVED, that the application of Christopher J. D'Angelo for the rezoning from MS-Motor Services District to CM-General Commercial District of the property described in the attached legal description be and the same is hereby approved, and BE IT FURTHER

RESOLVED, that the Zoning Map and Law of the Town Of Cheektowaga be amended in accordance with the above.

LEGAL DESCRIPTION

ALL THAT TRACT OR PARCEL OF LAND situate in the Town of Cheektowaga, County of Erie, State of New York, being part of lot ALL THAT TRACT OR PARCEL OF LAND, SITUATE IN THE TOWN OF CHEEKTOWAGA, COUNTY OF ERIE AND STATE OF NEW YORK, AND BEING KNOWN AS PART OF LOT NUMBER 75, TOWNSHIP 11, RANGE 7 OF THE HOLLAND LAND COMPANY'S SURVEY, AND DESCRIBED AS FOLLOWS: COMMENCING AT THE CENTERLINE INTERSECTION OF TRANSIT ROAD (S.H. NO. 1334 A-I, PART 4) WITH GENESEE STREET (S.H. NO. 1212, PART 1); THENCE S-70-21'-08-W ALONG THE CENTERLINE OF GENESEE STREET, A DISTANCE OF 243.11 FEET TO A POINT; THENCE N-00-02'-26-E AND PARALLEL WITH THE CENTERLINE OF TRANSIT ROAD A DISTANCE OF 53.10 FEET TO THE PRINCIPAL POINT OF BEGINNING, BEING THE INTERSECTION OF THE EAST LINE OF LIBER 9548, PAGE 241 WITH THE NORTH LINE OF MAP 77, PARCEL 78, S.H. NO. 1212; FROM THE PRINCIPAL POINT OF BEGINNING: COURSE 1: THENCE N-00-02'-26-E, A DISTANCE OF 202.09 FEET TO THE POINT AT THE SOUTH LINE OF PERMANENT EASEMENT TO THE NEW YORK STATE DEPARTMENT OF PUBLIC WORKS AS SHOWN ON A MAP 141, PARCEL 153, TRANSIT ROAD, PART 4, S.H. 1334 A-I AND RECORDED IN LIBER 6320, PAGE 38;

COURSE 2: THENCE S-84-34'-22-E, ALONG THE SOUTH LINE OF PERMANENT EASEMENT TO THE NEW YORK STATE DEPARTMENT OF PUBLIC WORKS AS SHOWN ON A MAP 141, PARCEL 153, TRANSIT ROAD, PART 4, S.H. 1334 A-I AND RECORDED IN LIBER 6320, PAGE 38, A DISTANCE OF 31.41 FEET TO A POINT ;
COURSE 3: THENCE N-00-02'-26-E, A DISTANCE OF 35.71 FEET TO A POINT;
COURSE 4: THENCE S-89-57'-34-E, A DISTANCE OF 112.62 FEET TO A POINT;
COURSE 5: THENCE S-00-02'-26-W, 46.33 FEET TO A POINT;
COURSE 6: THENCE S-84-34'-22-E, 15.07 FEET TO THE POINT AT WESTERLY LINE OF TRANSIT ROAD (WIDTH VARIES);
COURSE 7: THENCE S-00-02'-26-W, ALONG A WESTERLY RIGHT OF WAY OF TRANSIT ROAD 100.28 FEET TO A POINT;
COURSE 8: THENCE WESTERLY S-20-18'-28-W, 36.82 FEET TO THE POINT AT THE NORTHERLY LINE OF GENESEE STREET (WIDTH VARIES);
COURSE 9: THENCE S-70-21'-08-W, ALONG THE NORTHERLY LINE OF GENESEE STREET (WIDTH VARIES) 212.92 FEET TO THE PRINCIPAL POINT OF BEGINNING. CONTAINING 31041.65 SQ.FT. OR 0.71 MORE OR LESS ACRES.

RESULT:	ADOPTED [UNANIMOUS]
MOVER:	Charles Markel, Councilmember
SECONDER:	Stanley Kaznowski, Councilmember
AYES:	Holtz, Jaworowicz, Swiatek, Rogowski, Zydel, Markel, Kaznowski



9. RESOLUTION 2011-634

Notice to Bidders Portable Chemical Toilets 2012

Sponsored By: Councilmember Rogowski, Supervisor Holtz

WHEREAS, The Town of Cheektowaga, Facilities Department, Parks Division, utilizes Portable Chemical Toilets at various locations to service their recreational activities and Special Events, NOW BE IT

RESOLVED, that the Town Clerk be directed to publish a Notice To Bidders for the Leasing and Servicing of Portable Chemical Toilets, AND BE IT FURTHER

RESOLVED, that specifications for said Leasing and Servicing of Portable Chemical Toilets be obtained from the Town Clerk's Office in Cheektowaga Town Hall, AND BE IT FURTHER

RESOLVED, that sealed bids will be received on the 14th day of December, 2011 at 11:00 AM Eastern Standard Time at a Public bid opening to be held in the Council Chambers at Cheektowaga Town Hall.

-- Notice to Bidders

Sealed proposals will be received by the Town Clerk on December 14, 2011 at 11:00 AM Eastern Standard Time at the Town Hall, 3301 Broadway, for Leasing and Servicing of Portable Chemical Toilets for the year 2012.

Information for bidders and specifications may be obtained from the Town Clerk at her office in Town Hall.

The Town Board reserves the right to consider informal any bid not prepared and submitted in accordance with the provisions of the specifications and contract documents and may waive any informalities, make an award to other than the low bidder should it be in the best interest of the Town, or reject any or all bids.

By Order of the Town Board of the Town of Cheektowaga, Erie County, New York.

Alice Magierski
Town Clerk

Date: December 5, 2011

RESULT:	ADOPTED [UNANIMOUS]
MOVER:	James Rogowski, Councilmember
SECONDER:	Mary Holtz, Supervisor
AYES:	Holtz, Jaworowicz, Swiatek, Rogowski, Zydel, Markel, Kaznowski



10. RESOLUTION 2011-635

Change Order - Asbestos Removal for 89 Gardenvale

Sponsored By: Councilmember Markel, Councilmember Kaznowski

WHEREAS, by resolution dated May 2, 2011 (Resolution 2011-241), this Town Board awarded a contract with AFI for the asbestos survey, monitoring and abatement for 89 Gardenvale Drive, and

WHEREAS, during demolition, additional asbestos was detected in the roofing materials on the building, and

WHEREAS, as per the Town's engineering consultant, the abatement of said additional asbestos material required additional expense for the project, NOW, THEREFORE, BE IT

RESOLVED, that this Town Board hereby approves a Change Order in the amount of \$1,250.00 for the additional work involved, in the project, and BE IT FURTHER

RESOLVED, that said additional moneys in the amount of \$1,250.00 shall be appropriated from budget line item number 0800-800-0440.

RESULT:	ADOPTED [UNANIMOUS]
MOVER:	Charles Markel, Councilmember
SECONDER:	Stanley Kaznowski, Councilmember
AYES:	Holtz, Jaworowicz, Swiatek, Rogowski, Zydel, Markel, Kaznowski



11. RESOLUTION 2011-636

Award of Bid - Two (2) New and Unused, 2012 Model or Newer, Tandem Drive Axle Cab and Chassis Heavy Duty Dump/Plow Trucks

Sponsored By: Councilmember Swiatek, Supervisor Holtz

WHEREAS, bids were received and opened by the Town Clerk at a public bid opening held on November 23, 2011, for Two (2), New and Unused, 2012 Model or Newer, Tandem Drive Axle Cab and Chassis Heavy Duty Dump/Plow Trucks for use by the Town of Cheektowaga Highway Department as a result of advertisement thereof, and such bid was referred to the Superintendent of Highway for Analysis, tabulation and reports, AND

WHEREAS, bids were analyzed and completed, NOW THEREFORE BE IT

RESOLVED, the responsible bidder meeting specs for Two (2) New and Unused, 2012 Model or Newer, Tandem Drive Axle Cab and Chassis Heavy Duty Dump/Plow Trucks be awarded to Fleet Maintenance, Inc., 67 Ransier Drive, West Seneca, NY 14224 at a total bid price of \$221,848.00 said bidder meeting specifications of bid. AND, BE IT FURTHER

RESOLVED, that monies be charged to line item 300-5130-2407.

TABULATION FOR TWO (2), NEW AND UNUSED, 2012 MODEL OR NEWER, TANDEM AXLE CAB AND CHASSIS HEAVY DUTY BUMP/PLOW TRUCKS

Fleet Maintenance, Inc.
67 Ransier Drive
West Seneca, NY 14224
(716) 675-9220

	\$219,922.00
options	<u>1,926.00</u>
Total	\$221,848.00

Kenworth of Buffalo NY, Inc.
100 Commerce Drive
Buffalo, NY 14218
(716) 852-2800

	\$237,262.00
options	<u>2,250.00</u>
Total	\$239,512.00

RESULT:	ADOPTED [UNANIMOUS]
MOVER:	Jeff Swiatek, Councilmember

SECONDER: Mary Holtz, Supervisor

AYES: Holtz, Jaworowicz, Swiatek, Rogowski, Zydel, Markel, Kaznowski



12. RESOLUTION 2011-637

Approve Extension of Pre-Hospital Emergency Services Agreement with Rural/Metro Medical Services

Sponsored By: Councilmember Zydel, Councilmember Markel

WHEREAS, by resolution dated December 21, 2009, the Town Board of the Town of Cheektowaga awarded an Agreement for Pre-Hospital Emergency Services with Rural Metro Medical Services, Inc. for ambulance services for emergencies which are called into the Cheektowaga Dispatch Office for 2010-11, and

WHEREAS, such agreement expired on December 31, 2011, but contained a provision for renewal for two (2) one-year periods upon the recommendation of the Emergency Medical Services Board ("EMS Board") and approval of the Town, and

WHEREAS, the EMS Board has recommended the approval of a renewal of the aforementioned agreement for calendar year 2012, NOW, THEREFORE, BE IT

RESOLVED, that this Town Board hereby approves the renewal of the aforementioned Agreement for Pre-Hospital Emergency Services with Rural Metro Medical Services, Inc. for calendar year 2012 on the same terms and conditions as set forth in said agreement, and BE IT FURTHER

RESOLVED, that the Supervisor be and hereby is authorized and directed to execute a Memorandum of Extension of said Agreement on behalf of the Town of Cheektowaga.

RESULT:	ADOPTED [UNANIMOUS]
MOVER:	Richard Zydel, Councilmember
SECONDER:	Charles Markel, Councilmember
AYES:	Holtz, Jaworowicz, Swiatek, Rogowski, Zydel, Markel, Kaznowski



13. RESOLUTION 2011-638

Renewal of Beverage Agreement with Pepsi Beverages Company

Sponsored By: Councilmember Rogowski, Councilmember Zydel

WHEREAS, the Town of Cheektowaga is the owner of the Recreation Center located at 2600 Harlem Road in Cheektowaga Town Park, and various other buildings in the Town, and

WHEREAS, in 2009, Pepsi Beverages Company was awarded the contract for the exclusive right to sell their beverages within Town facilities (Recreation Center/Ice Rink and other Town buildings), and

WHEREAS, Pepsi Beverages Company has submitted a proposal to the Town whereby it will give the Town of Cheektowaga \$3,000.00 per year for the next three (3) years (2012-2014), to obtain these exclusive rights, and

WHEREAS, Pepsi products are already being sold at the Recreation Center and in vending machines in Town buildings, and

WHEREAS, Pepsi Beverages Company has submitted to the Town for signature a "2012 Beverage Agreement", and

WHEREAS, said agreement has been reviewed by the Town Attorney and the Director of the Facilities Department, and has been found acceptable, NOW, THEREFORE, BE IT

RESOLVED, that the Supervisor be and hereby is authorized and directed to execute the aforementioned agreement on behalf of the Town of Cheektowaga.

RESULT:	ADOPTED [UNANIMOUS]
MOVER:	James Rogowski, Councilmember
SECONDER:	Richard Zydel, Councilmember
AYES:	Holtz, Jaworowicz, Swiatek, Rogowski, Zydel, Markel, Kaznowski



14. RESOLUTION 2011-639

Youth & Recreation Hiring

Sponsored By: Councilmember Zydel, Councilmember Rogowski

BE IT RESOLVED that the individuals listed below be and hereby are hired and/or transferred, as indicated, in the Department of Youth & Recreational Services, effective immediately:

Recreation Aide - 7140.1630 - \$7.25 - Part-time

Karisa Poczciwinski 14225

Recreation Attendant - 7140.1614 - \$9.25 - Regular Part-time

Sandra Rhoat 14206

Motion by Councilmember Rogowski; Seconded by Councilmember Markel to waive the reading of names for the following two (2) resolutions. 2011-639 and 2011-640. Motion Carried.

RESULT: ADOPTED [UNANIMOUS]
MOVER: Richard Zydel, Councilmember
SECONDER: James Rogowski, Councilmember
AYES: Holtz, Jaworowicz, Swiatek, Rogowski, Zydel, Markel, Kaznowski



15. RESOLUTION 2011-640

Hiring/Termination of Part-Time/Seasonal Employees

Sponsored By: Councilmember Swiatek, Supervisor Holtz

BE IT RESOLVED, that the following individual be and hereby is hired as a **PART-TIME EMPLOYEE** in the department listed, not to exceed nineteen (19) hours on a weekly basis, in compliance with Civil Service Laws and Regulations as well as the provisions of the Town's collective bargaining agreement between the Town of Cheektowaga and the Town of Cheektowaga Employees Association:

SENIOR SERVICES Van Driver (Substitute) \$8.75/hour effective 12/5/11
Gene R. Stark, Cheektowaga, New York

BE IT RESOLVED, that the following seasonal and/or part-time employees be and hereby are terminated as listed:

SANITATION DEPARTMENT
Ronnell J. Simmons effective 11/24/11
Craig M. Skierczynski effective 11/24/11
Daniel J. Woods effective 11/26/11
Justin P. Borowski 12/03/11
Norman D. Nuessle effective 11/08/11

RESULT:	ADOPTED [UNANIMOUS]
MOVER:	Jeff Swiatek, Councilmember
SECONDER:	Mary Holtz, Supervisor
AYES:	Holtz, Jaworowicz, Swiatek, Rogowski, Zydel, Markel, Kaznowski



16. RESOLUTION 2011-641

Reappointment of Civil Officers

Sponsored By: Councilmember Jaworowicz, Councilmember Rogowski

WHEREAS, pursuant to Section 20(1)(a) of the Town Law of the State of New York, this Town Board has the authority to appoint civil officers which possess the powers and duties of Constables in civil actions and proceedings, and

WHEREAS, The Town has a police department duly established pursuant to law, and

WHEREAS, there is a need to appoint civil officers to assist landlords with eviction proceedings initiated in the Cheektowaga Justice Court, and

WHEREAS, the Town Board of the Town of Cheektowaga, a duly constituted Town of the First Class, by prior resolutions, appointed Frank Krisnosky, Walter Geising (of Esquire Process Service, LLC) and Monique Geising (of Esquire Process Service, LLC) as civil officers of the Town of Cheektowaga possessing the powers and duties of a constable in civil actions and proceedings only for terms expiring on December 31, 2011, and

WHEREAS, the appointment of civil officers has been well-received by the residents of the Town of Cheektowaga and has proved to be beneficial to the Town; and

WHEREAS, the aforesaid civil officers have requested that their appointments be renewed for a three (3) year term, NOW, THEREFORE, BE IT

RESOLVED, that, pursuant to the authority granted by Town Law Section 20(1)(a), Frank Krisnosky, 2194 Colvin Boulevard, Tonawanda, New York 14150, Walter Geising of Esquire Process Service, LLC, P.O. Box 337, Lackawanna, New York 14218, and Monique Geising of Esquire Process Service, LLC, P.O. Box 337, Lackawanna, New York 14218, be and hereby are re- appointed as civil officers of the Town, possessing all the powers of a constable in civil actions and proceedings only for a term expiring on December 31, 2013; and BE IT FURTHER

RESOLVED, that said Civil Officers shall be paid no salary but shall be entitled to collect the statutory fees allowed by law in such civil actions and proceedings.

RESULT:	ADOPTED [UNANIMOUS]
MOVER:	Patricia Jaworowicz, Councilmember
SECONDER:	James Rogowski, Councilmember
AYES:	Holtz, Jaworowicz, Swiatek, Rogowski, Zydel, Markel, Kaznowski



17. RESOLUTION 2011-642

Appointment of Student Interns/Police Department

Sponsored By: Councilmember Jaworowicz, Councilmember Swiatek

WHEREAS, Grzegorz J. Gasiorczyk, a student at Erie Community College, and Kaitlyn M. Gallagher, a student at Hilbert College, have requested to participate in the student internship program in the Police Department; AND

WHEREAS, these individuals have been interviewed by the Police Department and the Police Department is willing to afford them the opportunity to intern in the Police Department; NOW, THEREFORE, BE IT

RESOLVED, that Grzegorz J. Gasiorczyk of Lancaster, New York, and Kaitlyn M. Gallagher of Cheektowaga, New York, be and hereby are authorized to participate as unpaid interns in the Police Department, subject to their executions of a Waiver of Liability and Agreement of Confidentiality; AND, BE IT FURTHER

RESOLVED, that Mr. Gasiorczyk's internship be and hereby is effective October 1, 2011 through February 29, 2012, and Ms. Gallaghers's internship be and hereby is effective January 1, 2012 through February 29, 2012; AND, BE IT FURTHER

RESOLVED, that the Town Supervisor be and hereby is authorized and directed to execute the Agreement of Confidentiality, and all other documents necessary to effectuate these student internships in the Police Department.

RESULT:	ADOPTED [UNANIMOUS]
MOVER:	Patricia Jaworowicz, Councilmember
SECONDER:	Jeff Swiatek, Councilmember
AYES:	Holtz, Jaworowicz, Swiatek, Rogowski, Zydel, Markel, Kaznowski

**18. RESOLUTION 2011-643****Travel Authorization Police Department/Captain James Speyer**

Sponsored By: Councilmember Jaworowicz, Councilmember Swiatek

WHEREAS, the "Public Safety Officers' Benefits Training" is being held January 10, 2012 in Albany, New York; AND

WHEREAS, Captain James Speyer has requested authorization to attend said training; AND

WHEREAS, Police Chief David Zack has submitted a request for travel authorization along with the proper paperwork in a timely manner; AND

WHEREAS, the total cost to the Town shall not exceed \$187; AND

WHEREAS, these expenses have been budgeted by the Police Department; NOW, THEREFORE, BE IT

RESOLVED, that Captain James Speyer be and hereby is authorized to attend "Public Safety Officers' Benefits Training" being held January 10, 2012 in Albany, New York.

RESULT:	ADOPTED [UNANIMOUS]
MOVER:	Patricia Jaworowicz, Councilmember
SECONDER:	Jeff Swiatek, Councilmember
AYES:	Holtz, Jaworowicz, Swiatek, Rogowski, Zydel, Markel, Kaznowski



19. RESOLUTION 2011-644

Travel Authorization Police Department/Lieutenant Thomas Wentland, Detectives James Genson, Christopher Chojnacki and Joseph Bauman

Sponsored By: Councilmember Jaworowicz, Councilmember Swiatek

WHEREAS, a seminar entitled "The Reid Techniques of Interviewing and Interrogation" is being held January 4 through January 6, 2012 at Hilbert College; AND

WHEREAS, Lieutenant Thomas Wentland, Detective James Genson, Detective Christopher Chojnacki and Detective Joseph Bauman have requested authorization to attend said seminar; AND

WHEREAS, Police Chief David Zack has submitted a request for travel authorization along with the proper paperwork in a timely manner; AND

WHEREAS, the total cost to the Town shall not exceed \$1,776; AND

WHEREAS, these expenses have been budgeted by the Police Department; NOW, THEREFORE, BE IT

RESOLVED, that Lieutenant Thomas Wentland, Detective James Genson, Detective Christopher Chojnacki and Detective Joseph Bauman be and hereby are authorized to attend "The Reid Techniques of Interviewing and Interrogation" being held January 4 through January 6, 2012 at Hilbert College.

RESULT:	ADOPTED [UNANIMOUS]
MOVER:	Patricia Jaworowicz, Councilmember
SECONDER:	Jeff Swiatek, Councilmember
AYES:	Holtz, Jaworowicz, Swiatek, Rogowski, Zydel, Markel, Kaznowski

IV. Communications

A. Departmental Communications

1. Building Permits - November 2011
2. Minutes: Cheektowaga Planning Board - November 10, 2011

B. General Communications

1. Notice of Claim: Aaron D. Bell Vs. Town of Cheektowaga

V. Comments

A. Supervisor's Comments

B. Councilmember's Comments

C. Public Comments

VI. Adjournment

Motion by Supervisor Holtz; Seconded by Councilmember Rogowski to adjourn the meeting at 7:03 PM

Alice Magierski, Town Clerk

NOTES

- FOR REFERENCE INFORMATION SEE ALTA/ACSM SURVEY PREPARED BY GENESSEE ENGINEERING, PLANNING, SURVEYING, P.C. DATED MARCH 17, 2008 AND IDENTIFIED AS JOB NO. 8200-057, INCLUDED WITH THIS SET OF SITE PLANS.
- ALL CONSTRUCTION SHALL CONFORM TO TOWN OF CHEEKTOWAGA STANDARDS AND NEW YORK STATE CODE REQUIREMENTS, AS WELL AS THE LATEST A.I.S.C., A.C.I., O.S.H.A., AND A.S.T.M. STANDARDS WHERE CODES OVERLAP, THE CONTRACTOR SHALL COMPLY WITH THE MORE STRINGENT CODE.
- WHERE A SPECIFIC MANUFACTURER'S PRODUCT IS CALLED OUT ON THIS SHEET OR ANY OTHER PLAN IN THIS SET OF DRAWINGS, THE CONTRACTOR MUST COMPLY WITH THE MANUFACTURER'S LATEST PRINTED INSTRUCTIONS AND RECOMMENDATIONS FOR INSTALLATION.
- DURING CONSTRUCTION THE CONTRACTOR SHALL ERECT AND MAINTAIN AS NECESSARY ALL TEMPORARY BARRICADES, SAFETY FENCING, CAUTION LIGHTS, OR SIGNAGE TO PROTECT THE WORK ACTIVITY AND TO ENSURE PUBLIC SAFETY, OPTIMA DESIGN & ENGINEERING, PLLC SHALL NOT BE RESPONSIBLE FOR ANY INJURIES TO WORKERS OR PEDESTRIANS AS RESULT OF EXCAVATION OR CONSTRUCTION ACTIVITIES.
- ALL TRAFFIC CONTROL AND WARNING SIGNS SHALL CONFORM TO N.Y.S.D.O.T. MANUAL OF UNIFORM TRAFFIC CONTROL DEVICES.
- THE CONTRACTOR SHALL MAINTAIN ACCESSIBLE PASSAGEWAYS FOR TRAFFIC AND PEDESTRIANS TO EXISTING BUSINESSES WHICH WILL REMAIN IN OPERATION THROUGHOUT THE DURATION OF THE CONSTRUCTION.
- ANY CAST-IN-PLACE CONCRETE SHALL CONFORM TO N.Y.S.D.O.T. STANDARD SPECIFICATIONS (SECTION 0505) FOR CONCRETE AND TO THE LATEST A.C.I. CODE OF PRACTICE FOR CONCRETE. ALL CONCRETE SHALL BE CURED WITH WET BURLAP OR OTHER APPROVED CONCRETE CURING METHODS. PORTLAND CEMENT SHALL BE USED TO PRODUCE CONCRETE SHALL CONFORM WITH BOTH ACI 318 AND ASTM C1157.
- CONCRETE SHALL HAVE A SLUMP OF NO MORE THAN 5" AND AN AIR ENTRAINMENT OF 4-6% IN TEMPERATURES LESS THAN 40° F. AND MAINTAIN PROPER CURING PROCEDURES IN ACCORDANCE WITH ALL A.C.I. REQUIREMENTS.
- ALL CONCRETE CURBS, SIDEWALKS, AND PADS SHALL BE CURED BY SPRAYING ON A FLOKEMED CURING COMPOUND CONFORMING TO A.S.T.M. C309.
- THE CONTRACTOR SHALL VERIFY EXISTING CONDITIONS IN THE FIELD PRIOR TO THE START OF WORK. ANY DISCREPANCIES BETWEEN REAL LIFE CONDITIONS AND THIS SET OF SITE PLAN DRAWINGS SHALL BE BROUGHT TO THE ATTENTION OF THE DESIGN ENGINEER IMMEDIATELY FOR FURTHER INSTRUCTIONS. FAILURE TO NOTIFY OPTIMA DESIGN & ENGINEERING, PLLC OF ANY DISCREPANCIES CONSTITUTES THE CONTRACTOR'S ACCEPTANCE OF ALL THE CONDITIONS SHOWN ON THIS SET OF SITE PLANS.
- ANY DEVIATION FROM ANY PLANS IN THIS DRAWING SET SHALL REQUIRE APPROVAL OF OPTIMA DESIGN & ENGINEERING, PLLC AND THE TOWN OF CHEEKTOWAGA PLANNING, SURVEYING, AND ENGINEERING DEPARTMENTS, AS WELL AS THE TOWN APPROPRIATE UTILITY COMPANIES AND SERVICE PROVIDERS.
- ALL CONSTRUCTION OR EXCAVATION ACTIVITIES AND UTILITY INSTALLATIONS SHALL STRICTLY COMPLY WITH THE LATEST SAFETY STANDARDS AND REGULATIONS SET FORTH BY O.S.H.A., THE NEW YORK STATE HIGH VOLTAGE PROXIMITY ACT, AND NEW YORK STATE INDUSTRIAL CODE RULE 53.
- THE CONTRACTOR SHALL MAINTAIN INSURANCE THAT SHALL PROTECT HIM/HER FROM ANY LIABILITY UNDER WORKER'S COMPENSATION ACTS AND OTHER EMPLOYEE BENEFIT ACTS IN DAMAGES, BODILY INJURY, OR DEATH.
- THE CONTRACTOR SHALL PROVIDE A BARRIER & COVERED WALKWAY AS REQUIRED PER 3306.5-3306.7 OF NYS CODE DURING CONSTRUCTION.
- THE CONTRACTOR SHALL BE RESPONSIBLE FOR PAYING ALL NECESSARY FEES AND OBTAINING ALL NECESSARY PERMITS PRIOR TO THE START OF CONSTRUCTION. CONTACT TOWN OF CHEEKTOWAGA BUILDING DEPARTMENT (686-3470) FOR INSTRUCTIONS, PERMIT APPLICATIONS, AND FEES.

LEGEND

- EXISTING SIGN
- NEW SIGN
- EXISTING EDGE OF PAVEMENT
- NEW EDGE OF PAVEMENT
- EXISTING CURB
- NEW CURB (6")
- SITE PARCEL PROPERTY/R.O.W. LINE
- ADJACENT PROPERTY/R.O.W. LINES
- EXISTING UTILITY POLE
- EXISTING FIRE HYDRANT
- EXISTING LIGHT FIXTURE
- NEW LIGHT FIXTURE
- DIRECTIONAL ARROW (NOT PAINTED ON PAVEMENT)
- EXISTING CONCRETE AREAS
- NEW CONCRETE AREAS
- NEW ASPHALT PAVEMENT AREAS

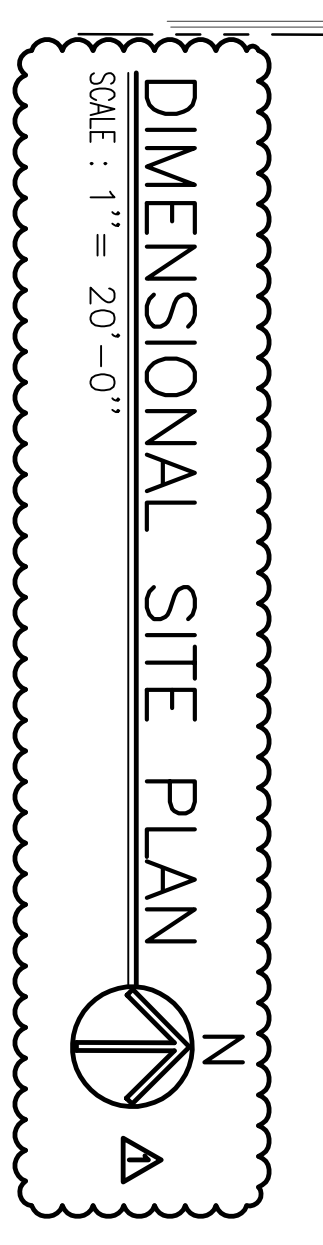
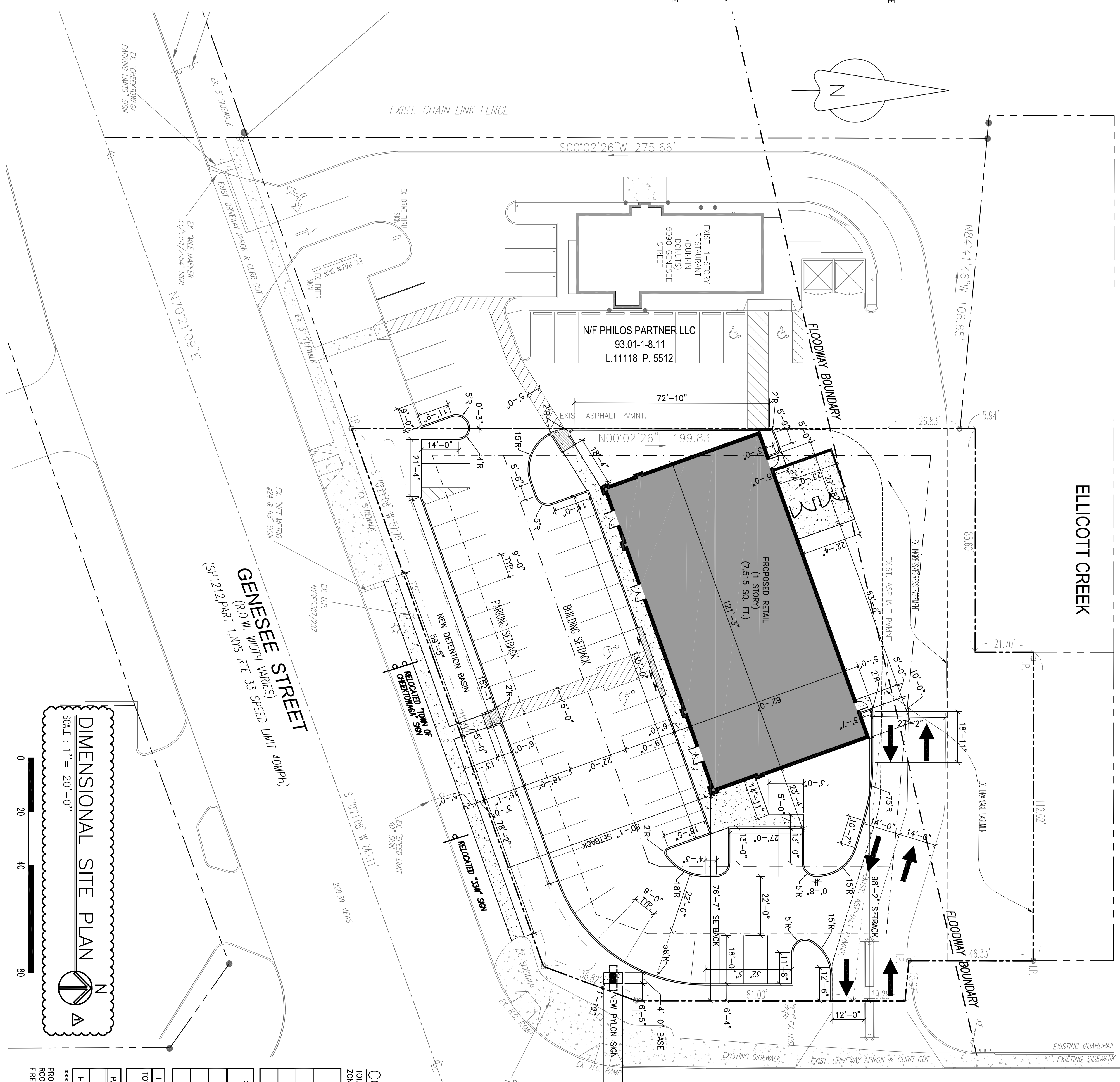

GENESEE STREET
(R.O.W. WIDTH VARIES)
(SH1212 PART 1 NYS RTE 33 SPEED LIMIT 40MPH)

TRANSIT ROAD
(R.O.W. WIDTH VARIES)
(US RT. 20 NYS RT. 78, SH #1334A-1, PART 4 SPEED LIMIT 45MPH)

CODE & SITE DATA

TOTAL PARCEL = 1.00 ACRES (44,340 SQ. FT.)
ZONED: MS (MOTOR SERVICE)

BUILDING SETBACK	REQUIRED	PROVIDED
FRONT	50'-0"	80'-1"
SIDE	10'-0"	1'-1"
REAR	10'-0"	47'-10"
PAVEMENT SETBACK	REQUIRED	PROVIDED
FRONT	25'-0"	6'-5" *****
SIDE	10'-0"	0'-0" *****
REAR	10'-0"	16'-11"
LANDSCAPE	REQUIRED	PROVIDED
TOTAL PARCEL	15%	28%
INTERIOR	5%	7%
PARKING	REQUIRED	PROVIDED
TOTAL	33 SPACES	45 SPACES
HANDICAP	2 SPACES	2 SPACES

***** RECEIVED VARIANCE FROM Z.B.A. JULY, 2011
PROP. BLDG. FOOTPRINT = 47,515 SQ. FT. (GROSS)
ROOF MATERIAL: SINGLE-PLY MEMBRANE
FIRE PROTECTION: SPRINKLER NOT REQ'D BY CODE

THE CONTRACTOR SHALL CONTACT THE DESIGN ENGINEER IMMEDIATELY UPON DISCOVERY OF ANY DISCREPANCIES BETWEEN THE REAL LIFE CONDITIONS AND THIS SET OF SITE PLAN DRAWINGS. FAILURE TO NOTIFY OPTIMA DESIGN & ENGINEERING, PLLC OF ANY DISCREPANCIES CONSTITUTES THE CONTRACTOR'S ACCEPTANCE OF ALL THE CONDITIONS SHOWN ON THIS SET OF SITE PLANS.

TRANSIT / GENESEE RETAIL PLAZA
5100 GENESEE STREET
CHEEKTOWAGA, NEW YORK 14225

DIMENSIONAL SITE PLAN

ISSUED FOR SITE PLAN REVIEW	6/29/11
REVISION PER AGENT REVIEW	8/29/11
STAMP/SEAL	

optima
4245 Union Road, Suite 102
Buffalo, New York 14225
Tel: (716) 814-0404
Fax: (716) 814-0404

DRAWN BY: ANT
CHECKED BY: OST
SHEET C-1.1
JOB # 11-79

SEQR

State Environmental Quality Review
NEGATIVE DECLARATION
 Notice of Determination of Non-Significance

Date: December 5, 2011

This notice is issued pursuant to Part 617 of the implementing regulations pertaining to Article 8 of the Environmental Conservation Law (State Environmental Quality Review Act) and Chapter 107 of the Town of Cheektowaga Code (Environmental Impact Review).

The Town of Cheektowaga Town Board, as lead agency, has determined that the proposed action described below will not have a significant adverse environmental impact and a Draft Environmental Impact Statement (“DEIS”) will not be prepared.

Name of Action: 2480-2550 Walden Avenue – Commercial Rezoning, 185,000 SF Retail (the “Project”)

SEQR Status: Type 1

Conditioned Negative Declaration: No

Location of Action: 2480 and part of 2490-2550 Walden Avenue, Cheektowaga, Cheektowaga County, New York.

Description of Action:

The applicant, Benderson Development Company, LLC (“Benderson” or the “Applicant”), has requested that the Town Board change the zoning classification of 17.43 acres of property located at 2480 and part of 2490-2550 Walden Avenue, in the Town of Cheektowaga, Erie County, New York (the “Site”), from the existing M-1 Light Manufacturing District to the CM General Commercial District (the “Project”).

The 17.43 acre site is rectangular and includes approximately 838 linear feet of frontage along Walden Avenue, a principal arterial highway. The Site is presently in the M-1 Light Manufacturing District and is improved with a 122,500 s.f. retail flea market, a 30,000 s.f. retail/office building, a 32,000 s.f. retail/office building and a 3,500 s.f. retail building with an existing restaurant and vacant retail space. The existing Retail and Restaurant uses are not permitted uses in the current M-1 Light Manufacturing zoning district and thus, became lawful non conforming uses at the time of the Town’s adoption of its current Zoning Law in 1992. As noted above, the Site is completely developed and consists of four buildings containing approximately 188,000 s.f. of building area, as well as other improvements including pavement, drainage and site lighting. The Site presently maintains five curb-cuts onto Walden Avenue. Only a six foot high stockade fence buffers the residents located to the north from the existing commercial uses. In effect, presently there is not a buffer between these residents and the

Attachment: notice of determination (RES-2011-631 : Negative SEQR Determination - 2480,2490-2550 Wald)

existing buildings. In addition, only minimal green space presently exists on the Site.

The Applicant is seeking to have the Site rezoned to reflect its current commercial uses as well as to plan for the redevelopment of the site with a maximum development potential of 185,000 s.f. The Applicant's desires to market the Site for future big box retail uses, and has not identified any potential future uses beyond commercial uses generally. A concept site plan of the proposed development has been provided to facilitate the environmental review of the maximum potential commercial development of the Site.

In addition, the Applicant has proposed the following:

- At the time of development, the removal of existing pavement and the addition of a 50' buffer between the proposed development and the abutting residential properties to the north and the west. The Applicant has proposed buffering that will utilize berms, planted with 6' high Colorado Spruces planted 15' on center along with the addition of a new 6' board-on-board fence. The result will be a 50' planted buffer for the residential neighbors where currently no buffer exists.
- To consolidate the existing driveways and reduce the number of driveways onto Walden Avenue from five (5) to three; and provide for a traffic signal. The result will be a single main driveway with a traffic signal and with two secondary driveways.
- To significantly upgrade green space both along the edges of the property, as well as internal to the property.

As part of the application, the Applicant provided the Town Board with an Expanded Full Environmental Assessment Form ("FEAF") which includes the following information: (1) Traffic Impact Study, prepared by TY Lin International, last revised April 8, 2011 (Appendix A to the FEAF); (2) Noise Impact Assessment, prepared by Angevine Consultants, Inc, dated March 30, 2011, and June 28, 2011 (Appendix B to the FEAF); (3) Preliminary Stormwater Management Report, prepared by TY Lin International, dated March 2011 (Appendix C to the FEAF); (4) FIRM Flood Insurance Rate Map (Appendix D to the FEAF); (5) NYSSHPO Map (Appendix E to the FEAF); (6) Line of sight drawings and visual renderings (Appendix F to the FEAF) and (7) a concept photometric plan prepared by WLS Lighting Systems dated April 28, 2011 (Appendix G to the FEAF).

Affirmative Segmentation:

The Applicant, in its request to rezone the property, has indicated that it has neither a definite plan for the future use of the property nor a specific tenant for the proposed development, and has requested the rezoning to a more restrictive commercial zoning district to enable the property to be marketed more effectively to potential tenants. While the Applicant has submitted a FEAF, which contains expert studies that demonstrate that the rezoning and redevelopment of the property from its current M1- Light Manufacturing zoning district to the

more restrictive CM- General Commercial zoning district will not create significant adverse environmental impacts, comments have been received that the Town Board should analyze the impacts of a tenant-specific site plan.

At this time, such a review is not possible. In fact, the Town Board finds that such a review would be inappropriate and beyond the scope of this particular legislative action. The Town Board finds that the circumstances here clearly warrant and legally justify an affirmative segmentation of the rezoning action from any and all subsequent actions, including the review of a tenant-specific site plan.

Reasons supporting segmenting the change in zone of the property from future actions, including the review of a tenant specific site plan include:

1. Approval of the change of zone request is in no way contingent on future development plans or approvals. Likewise, the Town Board is not obligated or authorized to approve any action, nor is the approval of the change of zone “practically determinative” of a subsequent action. In fact, without the rezoning action, a number of land uses currently permitted as of right within the M1- Light Manufacturing zoning have the potential for creating significant environmental impacts, including noise impacts, traffic impacts, air resource impacts, and potential impacts to community character. A down zoning of the subject site will eliminate currently permitted uses which may have a greater potential for negative environmental impacts ;
2. The potential future development of the property has been analyzed and discussed to the fullest extent practicable in the context of the review of the current project. The Applicant has provided a concept plan as well as a number of expert studies and reviews of the proposed concept plan, so as to enable the Town Board to assess the potential environmental impacts of a commercial use of the site even though no specific tenant or site user has been identified presently; and
3. Future actions to approve a tenant-specific site plan will require separate and independent action by the Town Board, through review and approval of a tenant-specific site plan, as well as agencies, boards and departments which will be involved during the Town Board’s review, including the New York State Department of Transportation, New York State Department of Environmental Conservation, Erie County Planning Department, Town of Cheektowaga Traffic Safety Commission, the Town Planning Board, and others. All of these agencies have been coordinated with as part of this SEQRA review and the Town Board would be re-established as the SEQRA lead agency to ensure compliance with SEQRA before any permit for development are issued should a future project be proposed. Additionally, as set forth above, the Town Board has reviewed a concept plan in connection with the current SEQRA review. As a result, segmenting the Town’ Board’s change-in-zone from the approval of a tenant-specific site plan will be no less protective of the environment nor will it hinder or affect that review. Based on the forgoing, segmenting this SEQRA review is warranted and justified in accordance with the SEQRA regulations of 6 NYCRR 617.3(g)(1).

The Town Board's SEQRA review and significance determination memorialized herein are limited solely to the Town Board's action changing the zoning district from the existing M-1 Light Manufacturing District to the CM General Commercial District. The separate site plan review and approval action required prior to the issuance of any building permit for a tenant-specific project will be subject to an independent review under SEQRA. Therefore, this limited legislative action is not expected, in and of itself, to have any direct or indirect significant adverse impacts on any environmental resources.

Nevertheless, for purposes of this SEQRA determination, the Town Board has analyzed the potential impacts of the rezoning action as well as potential future commercial uses of the Property. The rezoning action and such future uses (analyzed based upon the site's maximum commercial build-out potential) are hereinafter referred to as "the rezoning action and any subsequent Project" or collectively as "the Project."

Reasons Supporting this Determination:

(See 617.7(a)-(c) for requirements of this determination)

After considering the criteria for determining significance as set forth in 6 NYCRR § 617.7(e), the Town Board has determined, for the reasons discussed below, that the proposed Project will not have a significant adverse impact on the environment and the issuance of a negative declaration under SEQRA is warranted.

Zoning and Land Use.

The proposed rezoning is consistent with the zoning in the area and will significantly improve this property and the community. The Site abuts property to the east along Walden Avenue that is in the CM- General Commercial zoning district. Additionally, to the rear of the Site are houses in the R-Residence District. Down zoning the Property to the CM- General Commercial zoning district, a more restrictive zoning classification, is appropriate and consistent with the present use as well as the zoning districts in the area. This change will allow for cohesive future development. In addition, rezoning the Site will reduce the potential for conflict with the surrounding community. While retail uses can be designed to be compatible with residential uses, the uses permitted on the property as-of-right in the M1- Light Manufacturing zoning district have the potential to conflict with the adjacent residential uses. Many of the uses permitted in the M1- Light Manufacturing zoning district have the potential to result in impacts to abutting residential homes, which include increased noise, truck traffic and odors. The impacts of the uses allowed by right in the M1- Light Manufacturing zoning district, which include uses such as (1) manufacturing and assembling, (2) warehousing; (3) processing of metal and metal products; (4) food processing or packaging; (5) bottling of beverages; and (6) public utility storage or service, are significant considering that no buffer exists between the existing buildings and the existing residential uses. Rezoning the Site would reduce this potential for conflict and avoid negative impacts which could result if the Site was operated with the uses permitted under the existing zoning. The rezoning would be in accordance with the Town's

Comprehensive Plan. No significant adverse impacts with respect to zoning and land use are expected as a result of the change of zone from M1- Light Manufacturing to CM General Commercial.

Traffic

The rezoning action will result in a reduction of the total number of curb cuts at the site, minimizing potential operational conflicts, but in itself will not generate traffic or have any traffic related impacts. Nevertheless, for purposes of understanding a hypothetical future commercial use of the property, the Project would still not be expected to result in any significant traffic impacts in the area. In fact, with the reduction in the number of existing driveways from five (5) to three (3), as well as with the proposed addition of a traffic signal there will be a benefit to drivers on Walden Avenue.

To evaluate the Project's proposed traffic impacts, the Applicant's consultant, TY Lin International, conducted a comprehensive Traffic Impact Study, last revised April 8, 2011 (the "TIS"). A copy of this study was submitted to the Town as appendix A to the FEAF. In general, the study concluded that the traffic generated by the Project will not result in any significant adverse impacts on the existing levels of service at nearby intersections. In addition to the Town Board, the TIS was reviewed by both the Town of Cheektowaga Traffic Safety Committee and the New York State Department of Transportation (see May 17, 2011, NYSDOT Correspondence attached).

The traffic study contains the following: (1) an evaluation of existing traffic volumes and patterns; (2) a projection of future traffic volumes generated by the Project and growth in the area; (3) a traffic operations analysis; and (4) a traffic signal warrant analysis

Existing traffic volumes were collected by TY Lin International on Wednesday, November 17, 2010 and Saturday, November 20, 2010 at three (3) external intersections in the site's vicinity and on Saturday, March 26, 2011 at each of the five (5) existing site driveways. The Town was contacted and there are no known background developments to add to the future traffic. The estimated trip generation of the Project was added to the existing traffic volume to project future 2012 (build) traffic volumes.

The proposed, maximum build out of the site would generate a total of 221, 961 and 1278 vehicle trips during the weekday morning, weekday evening and Saturday midday peak hours, respectively. The signalized intersections at Walden Avenue/Union Road and Walden Avenue/Dick Road will operate at an acceptable Level of Service "D" or better with the minor improvements which will be implemented as part of the Project.

Based on the comprehensive analysis contained in the traffic study, the Town Board determines that the Project will not have any significant adverse impacts on traffic using the roadway network around the Site.

Noise

The rezoning action will, in itself, not generate noise. Nevertheless, for purposes of understanding a hypothetical future commercial use of the property, noise has been analyzed further and it is not expected that a future Project would result in any adverse change to noise levels on or around the Site. To evaluate the Project's proposed noise impacts, the Applicant's consultant, Angevine Acoustical Consultants, Inc., conducted a comprehensive Noise Impact Assessment ("NIA"), dated March 30, 2011, and amended on June 28, 2011. A copy of this study was submitted to the Town as appendix B to the FEAF. In general, the study concluded that the noise generated in connection with the Project will not result in any significant adverse impacts. The NIA concluded that received noise levels from building mechanical equipment and site traffic sources will be acceptable and in accordance with the daytime and nighttime noise level limits of the Town of Cheektowaga Noise Law and in comparison to daytime and minimum nighttime background noise levels.

As indicated in the NIA, the Project is not expected to result in any adverse change to noise levels on or around the Site compared to existing background noise levels. The Site is zoned for light industrial use and its environs are primarily commercial in nature. Ambient noise levels were surveyed at the boundaries of the Site and were found to be largely influenced by traffic on Walden Avenue. Other perceptible sources of noise include local traffic on Nagel Drive and Zoerb Avenue, rail traffic on CSX lines south of Walden Avenue, and airport traffic around Buffalo Niagara International Airport. During most of the week there is a continuous operation of a rooftop dust collector at a printing facility on Nagel Drive. During operating hours of the Super Flea Market on Saturdays and Sundays from 8:00 a.m. to 5:00 p.m. there is continual traffic and activities in the parking lot. On other days of the week during daytime hours there is occasional traffic in the parking lot generated by vendors and building support services for the Super Flea Market and from traffic generated by patrons of the adjacent commercial buildings. In addition, other contributing sources include the existing Site operation which includes snowplows and parking lot sweepers.

Consistent with the concept site plan, the NIA analyzed two potential types of retail store uses: a discount retail store with grocery and a home improvement store. Potential noise sources associated with the Project consists of traffic in parking lots and heating and ventilating equipment located on the rooftop. For the discount retail store, the models incorporated rooftop ventilation equipment for in-store tenants and rooftop grocery refrigeration systems. The NIA evaluated additional sources of noise that included merchandise deliveries, trucks and refrigeration trailers idling in docks, waste compactors, waste container delivery services, parking lot sweeping and snow removal.

Typical store design includes a number of site and building design factors that will attenuate noise. Typical with these types of buildings, the building facades along the perimeter of

the building will extend above the actual roof plane and will fully screen rooftop equipment. As proposed, a 50' landscape buffer and fencing will screen delivery truck loading docks and outdoor waste areas. The six foot high fence that will extend along the portion of the residential boundary on the back side of the building and will screen parking lot traffic and the associated noise.

The acceptability of noise from each of the store scenarios was evaluated in comparison with the relevant requirements of Chapter 166 of the Town of Cheektowaga Town Code. The Code provides a table of maximum permissible sound levels by receiving land use category. For properties zoned for business or manufacturing, sounds received at the real property boundaries of residential properties cannot exceed an A-weighted level of 65 dBA in daytime hours (7:00 a.m. to 11:00 a.m.) or 50 dBA in nighttime hours (11:00 p.m. to 7:00 a.m.). At property lines of adjacent businesses the respective limits are 65 dBA both for daytime and nighttime periods. At property lines of manufacturing facilities the respective limits are 75 dBA both for daytime and nighttime periods.

Sound sources associated with a typical discount retail store with grocery comprise of a number of rooftop air handling units of different sizes and a small number of refrigeration units installed over the retail and merchandise and grocery spaces, receiving and stock room spaces, and tenant spaces. Other sources include traffic in parking lots and at site entrances. It was concluded that the maximum noise levels from the combined facility rooftop sources and parking lot sources will not exceed 65 dBA daytime or 50 dBA nighttime sound level limits. In addition, the maximum predicted facility noise levels closely compare to the minimum background noise levels measured at the residential boundaries. No significant noise impacts were identified with a discount retail building.

Sound sources associated with typical home improvement store comprise a number of rooftop air handling units of different sizes excluding gardening center spaces. Other sources include traffic in parking lots and at site entrances. It was concluded that the maximum noise levels from the combined facility rooftop sources and parking lot sources will not exceed 65 dBA daytime or 50 dBA nighttime sound level limits. In addition, the maximum predicted facility noise levels closely compare to the minimum background noise levels measured at the residential boundaries. No significant noise impacts were identified with a home improvement center.

Assessments from various building services in daytime hours have determined that the maximum noise levels received along the adjoining residential boundaries should not exceed the 65 dBA daytime sound level limit and should largely compare to the daytime noise levels. Noise of operations of waste compactors, and from idling of trucks and trailers in docks, are not expected to be significant in comparison to the background noise levels as the result of the shielding of proposed screens. Sounds of idling trucks and refrigeration trailers at high speed are predicted to comply with the 50 dBA nighttime limit and closely compare to the minimum background noise levels along the majority of the boundary. Arrival and pullouts of merchandise delivery trucks and waste containers may generate minor increases above daytime background

noise levels at the boundary locations directly opposite the receiving docks. The duration of these events is brief and therefore no significant impacts will occur. Passbys of parking lot sweepers and snow plows along the edges of the main parking lot are not expected to affect noise levels along the majority of the northern boundary, and may only briefly increase noise levels a limited amount above daytime background noise levels.

Construction noise may result in a temporary increase in noise emissions. However, these noise emissions will be temporary in nature and all construction machinery will be equipped with the appropriate mufflers. The construction activities and finished Project will comply with all applicable State and local noise regulations.

Based on the foregoing discussion, the Project will not have any significant adverse noise impacts on the Site and its environs.

Groundwater

The rezoning and any subsequent Project will not have any significant adverse impact on the quality or quantity of groundwater resources in the area. There are no public water supply wells on the Site or on any of the adjacent lots. The Site is currently serviced by the Erie County Water Authority and the Project will continue to be supplied with all of its water from the Water Authority's existing public water distribution system. Groundwater reserves beneath the Site will not be utilized for potable or sanitary purposes by the Project and ground water reserves will remain at their current level. The Site is also currently connected to the Town's sanitary sewer system and the Project will continue this connection and will not impact the quality of groundwater in the area.

Surface Waters, Stormwater and Drainage

The rezoning and any subsequent Project will not have any significant adverse impact on the quantity or quality of surface water resources in the area. The Site contains no surface water resources and no Federal or State regulated wetlands or any other protected water courses have been identified on the Site.

To assess the potential impacts of a hypothetical future commercial use of the site, a Preliminary Stormwater Management report was prepared by the Applicant's consultant, TY Lin International, dated March 2011 and is attached to the FEAF as appendix C. The report included (1) background conditions, (2) existing site conditions, (3) proposed developed conditions, (4) stormwater management; (5) storm sewer design and analysis (6) pollution prevention measures; and (7) maintenance and inspection. The report identified the design of the stormwater management facilities for the Project and demonstrated compliance with the design requirements of the New York State Stormwater Management Design Manual and the Town of Cheektowaga. The report also outlined general pollution prevention measures and maintenance and inspection measures for the Site.

The most likely scenario for stormwater management is that runoff from the development of the Site would be collected in a closed conduit storm sewer that will direct the stormwater to an underground detention system. The underground detention system would then outlet to a water quality unit before discharging off-site. The total post-development run-off will be attenuated to less than existing conditions. The hydrology of the site will not vary significantly. A Storm Water Pollution Prevention Plan ("SWPPP") will also be prepared for the Project's construction phase as required by and in conformance with NYSDEC's General SPDES Permit for stormwater run-off associated with construction activities. As identified on the Preliminary Stormwater Management report, the SWPPP incorporates preventive measures and best management practices to control run-off. The proposed plans will be followed closely during construction and are expected to reduce, if not eliminate, any potential run-off impacts on or near the Site.

Also pursuant to NYSDEC's Stormwater program, all storm water management facilities will be inspected periodically and after storm events to remove debris, sediment build up and to ensure that the facilities are operating properly. Damaged facilities will be repaired immediately. All facilities will fully comply with all applicable Town of Cheektowaga standards.

Based on the foregoing, the rezoning and any subsequent Project will not have any significant adverse impact on the quantity or quality of surface water resources.

Solid Waste Disposal

The rezoning and any potential future Project will not have any significant adverse impact on the disposal of solid waste in the area. No waste will be disposed of on-site. All solid waste generated by the Project would be placed in permanently enclosed waste dumpsters. The dumpsters would be emptied or removed on a regular basis and transported off-site for recycling and/or disposal by a private waste management company.

Based on the foregoing discussion, the rezoning and any subsequent Project will not have any significant adverse impact on solid waste disposal.

Vegetation

The Site is not environmentally sensitive land or forest; instead, the Site is fully developed with four buildings comprising 188,230 s.f. of leasable space, as well as an associated parking field. There is presently minimal vegetation on Site.

Wildlife

The rezoning and any subsequent Project will not have any significant adverse impact on wildlife. The Site is covered by buildings or parking areas and is not a conducive wildlife habitat. No known endangered or threatened species (or their habitat) have been identified on the Site. The Project will not have any affect on aquatic wildlife as there is no surface body of

water located on or near the Site.

Community Character

The rezoning and any subsequent Project will not have any significant adverse impact on the community character in the area. The Site is located on Walden Avenue, a major commercial corridor in the Town. The area is improved by numerous retail, restaurant, light manufacturing and office uses. The rezoning and any subsequent Project will not contribute to sprawl as the area immediately surrounding the Site is commercial in nature. Walden Avenue is a commercial corridor which runs from the Village of Depew, through Cheektowaga, to the City of Buffalo. It is developed with buildings of similar size, many of which have similar uses, including offices, light manufacturers, wholesale distributors and retailers. A future redevelopment of the project site provides an opportunity to the Town to improve an project site which is currently a blight on the community character. As a result, the rezoning and any subsequent Project is not expected to have any significant adverse impacts on community character.

Historic and Archaeological Issues

The site has been completely disturbed and is improved with the existing buildings and pavement. The New York State Office of Parks, Recreation, and Historic Preservation (NYSSHPO) web site was consulted to determine the preliminary presence or absence of previously identified cultural resources within or adjacent to the Site and it was determined that the Site is not wholly or partially included within an identified archeologically sensitive area or substantially contiguous to a property listed or recommended for listing in the New York State or National Register of Historic Places (see attached map). As a result, the rezoning and any subsequent project is not expected to have any significant adverse impacts on historic or archaeological resources.

Visual Appearance

Overall, the rezoning and any subsequent Project will not have any significant adverse visual impacts on the surrounding community. The Applicant submitted line of site drawings and visual renderings for the area on the Site which abuts the existing residential development to the north and west. As demonstrated by those documents, the addition of a 50' landscaped buffer between the Site and the existing residences, where none presently exists, will result in a significant improvement in the visual appearance of the Site from those receptors.

Water Supply

The rezoning and any subsequent Project will not have any significant adverse impact on the area's water supply. Water will be supplied to the Project by the Erie County Water

Authority. As noted previously, the Erie County Water Authority currently provides water to the property. Sufficient water capacity exists in the existing water distribution system to supply the domestic and fire flow demands for a future commercial Project.

Sanitary Sewer Service

The rezoning and any subsequent Project will not have any significant adverse impact on the sanitary sewer system or its treatment facilities. Any future commercial Project will be serviced by the Town's existing sanitary sewer system currently servicing the property. Sufficient capacity exists in the Town's existing sewage treatment and distribution system to handle the flow from the Project.

Community Services

While a future Project may increase the demand for police services, the Town's Police Department has sufficient manpower and equipment to provide services to the Project. Police protection will be provided mainly by the Town of Cheektowaga Police Department.

Fire protection for the site will continue to be provided by the Town of Cheektowaga, Forks Fire District. The district has adequate equipment and personnel to fight any fires at the Project.

Miscellaneous

In addition to the foregoing, the Town Board has also determined that the Project will not result in:

1. the creation of a material conflict with the Town of Cheektowaga's current community development plans or goals as officially approved or adopted. The Project is consistent with the Town's Comprehensive Plan, the existing retail use of the Site and the commercial character of the area surrounding the Site.
2. the impairment of the character or quality of important historical, archeological, architectural or aesthetic resources.
3. the impairment of the environmental characteristics of a Critical Environmental Area as designated pursuant to 6 NYCRR § 617.14(g). No such area exist on or adjacent to the Site.
4. a major change in the use of either the quantity or type of energy.
5. the creation of a hazard to human health. The Project will actually promote the public health, safety and welfare by reducing driveways on Walden Avenue, and minimizing

traffic conflict points.

- 6. a substantial change in the use, or intensity of use, of land including agricultural, open space or recreational resources, or in its capacity to support existing uses. This is private property, not open to the public for recreational purposes. The property is currently being used as a retail flea market and is zoned for light industrial uses.
- 7. the encouraging or attracting of a large number of people to a place or places for more than a few days, compared to the number of people who would come to such place absent the action. Many of the people that will utilize this facility are already coming to the area to utilize the many commercial, retail and restaurant facilities that exist in the area around the Project Site.
- 8. the creation of a material demand for other actions that would result in one of the above consequences.
- 9. changes in two or more elements of the environment, no one of which has a significant impact on the environment, but when considered together result in a substantial adverse impact on the environment.
- 10. two or more related actions undertaken, funded or approved by an agency, none of which has or would have a significant impact on the environment, but when considered cumulatively would meet one or more of the criteria in 6 NYCRR § 617.7(c).

* * * * *

For all the reasons set forth above, it is clear that the proposed Project will not have any significant adverse impact on the environment and the issuance of a negative declaration under SEQRA is warranted. Moreover, the Town will conduct a separate SEQR review prior to consideration of any future site plan approval as previously stated in the affirmation of segmentation.

Attachment: notice of determination (RES-2011-631 : Negative SEQR Determination - 2480,2490-2550 Wald)

For Further Information:

Contact Person: Daniel J. Ulatowski, AICP, Planner

Address: Town of Cheektowaga
3301 Broadway
Ground Floor, Room 10
Cheektowaga, New York 14227

Telephone Number: (716) 686-3567

Filing: As required by 6 NYCRR § 617.12 a copy of this determination of non-significance shall be filed with the following:

- The Applicant;
- The Town of Cheektowaga Town Board, as the lead agency; and
- The Town of Cheektowaga Town Clerk;
- NYSDOT, Erie County Dept. of Env. & Planning, Forks Fire District;
- The editor of the Environmental Notice Bulletin (“ENB”);
- The Commissioner of the New York State Department of Environmental Conservation (“DEC”) and the DEC Regional Office

maj

SITE PLAN OR ZONING REFERRAL TO COUNTY OF ERIE, NY AND REPLY TO MUNICIPALITY

Note: Please complete in triplicate. Send original and one copy (with attachments) to Erie County Division of Planning, Room 1053, 95 Franklin Street, Buffalo, N.Y. 14202. Retain last copy for your files.

DO NOT WRITE IN THIS SPACE

Case No.: SP-11-73
Received: 1/11/11

The proposed action described herein is referred in accordance with the provisions of the General Municipal Law, which provides that if no reply is received in 30 days after receipt of full information including a SEQR EAF if applicable, the municipal agency may take final action without considering such reply. If, however, reply is received at any time prior to municipal Action, such reply must be considered.

Description of Proposed Action

1. Name of Municipality: Town of Cheektowaga

2. Hearing Schedule: Date TBA Time 7:00PM Location 3301 Broadway

3. Action is before: Legislative Body Board of Appeals Planning Board

4. Action consists of: New Ordinance Rezone/Map Change Ordinance Amendment
 Site Plan Variance Special Use Permit Other

5. Location of Property: Entire Municipality Specific as follows 2480 and Part of 2490-2550 Walden Avenue

6. Referral required as Site is within 500' of: State or County Property/Institution Municipal Boundary Farm Operation located in an Agricultural District
 Expressway County Road State Highway Proposed State or County Road, Property, Building/Institution, Drainageway

7. Proposed change or use: (be specific) Rezoning request M1 to CM for demolition of existing 184,500 sf retail/office space and construction of 185,000 sf retail building.

8. Other remarks: (ID#, SBL#, etc.) 103.13-2-5 and part of 103.13-2-6.1

9. Submitted by: Daniel J. Ulatowski, AICP, Zoning Inspector January 6, 2011
3301 Broadway, Cheektowaga, New York 14227

Reply to Municipality by Erie County Division of Planning

Receipt of the above-described proposed action is acknowledged on 1/11/11. The Division herewith submits its review and reply under the provisions of applicable state and local law, based on the information submitted with this referral.

- 1. The proposed action is not subject to review under the law.
- 2. Form ZR-3, Comment on Proposed Action is attached hereto.
- 3. The proposed action is subject to review; the Division makes the recommendation shown on Form ZR-4, Recommendation on Proposed Action, which is attached hereto.
- 4. No recommendation; proposed action has been reviewed and determined to be of local concern

The County consents to the Town of Cheektowaga acting as SEQR Lead Agency

By the Division of Planning: Rachel Chrostowski Date: 1/19/11

Attachment: notice of determination (RES-2011-631 : Negative SEQR Determination - 2480,2490-2550 Walden)



STATE OF NEW YORK
DEPARTMENT OF TRANSPORTATION
REGION FIVE
100 SENECA STREET
BUFFALO, NY 14203
www.nysdot.gov

DARRELL F. KAMINSKI, P.E.
ACTING REGIONAL DIRECTOR

JOAN McDONALD
COMMISSIONER

May 17, 2011

Daniel J. Ulatowski, AICP, Zoning Inspector
Building Inspections Office
Town of Cheektowaga
3301 Broadway
Cheektowaga, New York 14227

RE: SEQR/SITE PLAN REVIEW
2480 & Part of 2490-2550 Walden Ave~Rezoning
Walden Square Retail Development
Town of Cheektowaga

Dear Mr Ulatowski:

We reviewed the information submitted for the subject project, which includes a Traffic Impact Study (TIS) dated April 8, 2011. Based on this information we have the following comments:

- We concur with the Town of Cheektowaga acting as the Lead Agency.
- The TIS recommends adjusting the signal timings at the intersections of Walden Avenue at Union Road and at Dick Road. Adjustments will be implemented by the Department, if justified, based on actual traffic conditions after the proposed project is completed.
- A traffic signal at the main driveway will not be approved at this time. When a specific tenant for this site is identified, the Department will re-evaluate the need for a traffic signal. If and when a traffic signal is approved at the main driveway, then the existing Walden Avenue center two way left turn lane shall be re-stripped to provide a dedicated westbound and eastbound left turn lanes.
- Two entrance lanes, two exit lanes and a center median will be approved for the main driveway. Although not recommended in the TIS, a 12' wide westbound right turn lane on Walden Avenue shall be constructed with a minimum length of 150' and minimum taper of 120'. A land donation in fee may be necessary to accommodate the right turn lane, snow storage and sidewalk to be constructed within highway right-of-way.
- Regarding the proposed signal, the TIS states, "driveway locations and access to the properties on the south side of Walden Avenue will be coordinated during the site plan approval process." We concur with addressing this during the site plan approval process.

Mr. Daniel J. Ulatowski
Page 2

May 17, 2011

- The center two way left turn lane on Walden Avenue shall not be modified to provide a left turn lane, as recommended in the TIS, at the intersections of the proposed unsignalized driveways. This would apply to the main driveway as well, if a signal is not approved.

If you have any questions or comments, please contact me at 847-3575.

Sincerely,

Original Signed by
E. S. Rutkowski

EDWARD S. RUTKOWSKI, P.E.
SEQR/Site Plan Review Coordinator

ESR/lk

cc: Benderson Development Co.

Attachment: notice of determination (RES-2011-631 : Negative SEQR Determination - 2480,2490-2550 Wald)

617.20
Appendix A
State Environmental Quality Review
FULL ENVIRONMENTAL ASSESSMENT FORM

Purpose: The full EAF is designed to help applicants and agencies determine, in an orderly manner, whether a project or action may be significant. The question of whether an action may be significant is not always easy to answer. Frequently, there are aspects of a project that are subjective or unmeasurable. It is also understood that those who determine significance may have little or no formal knowledge of the environment or may not be technically expert in environmental analysis. In addition, many who have knowledge in one particular area may not be aware of the broader concerns affecting the question of significance.

The full EAF is intended to provide a method whereby applicants and agencies can be assured that the determination process has been orderly, comprehensive in nature, yet flexible enough to allow introduction of information to fit a project or action.

Full EAF Components: The full EAF is comprised of three parts:

- Part 1:** Provides objective data and information about a given project and its site. By identifying basic project data, it assists a reviewer in the analysis that takes place in Parts 2 and 3.
- Part 2:** Focuses on identifying the range of possible impacts that may occur from a project or action. It provides guidance as to whether an impact is likely to be considered small to moderate or whether it is a potentially-large impact. The form also identifies whether an impact can be mitigated or reduced.
- Part 3:** If any impact in Part 2 is identified as potentially-large, then Part 3 is used to evaluate whether or not the impact is actually important.

THIS AREA FOR LEAD AGENCY USE ONLY

DETERMINATION OF SIGNIFICANCE -- Type 1 and Unlisted Actions

Identify the Portions of EAF completed for this project: Part 1 Part 2 Part 3
Upon review of the information recorded on this EAF (Parts 1 and 2 and 3 if appropriate), and any other supporting information, and considering both the magnitude and importance of each impact, it is reasonably determined by the lead agency that:

- A. The project will not result in any large and important impact(s) and, therefore, is one which will not have a significant impact on the environment, therefore a **negative declaration will be prepared.**
- B. Although the project could have a significant effect on the environment, there will not be a significant effect for this Unlisted Action because the mitigation measures described in PART 3 have been required, therefore a **CONDITIONED negative declaration will be prepared.***
- C. The project may result in one or more large and important impacts that may have a significant impact on the environment, therefore a **positive declaration will be prepared.**

*A Conditioned Negative Declaration is only valid for Unlisted Actions

2480-2550 WALDEN AVENUE
Name of Action

TOWN OF CHEEKTOWAGA
Name of Lead Agency

MARY F. HOLTZ
Print or Type Name of Responsible Officer in Lead Agency

TOWN SUPERVISOR
Title of Responsible Officer

Signature of Responsible Officer in Lead Agency

Daniel J. Ulatowski
Signature of Preparer (if different from responsible officer)
DANIEL J. ULATOWSKI, AICP
PLANNER

11/30/2011
Date

Attachment: notice of determination (RES-2011-631 : Negative SEQOR Determination - 2480,2490-2550 Wald)

PART 1--PROJECT INFORMATION Prepared by Project Sponsor

NOTICE: This document is designed to assist in determining whether the action proposed may have a significant effect on the environment. Please complete the entire form, Parts A through E. Answers to these questions will be considered as part of the application for approval and may be subject to further verification and public review. Provide any additional information you believe will be needed to complete Parts 2 and 3.

It is expected that completion of the full EAF will be dependent on information currently available and will not involve new studies, research or investigation. If information requiring such additional work is unavailable, so indicate and specify each instance.

Name of Action 2480 - 2550 Walden Ave - Commercial Rezoning, 185,000 SF retail

Location of Action (include Street Address, Municipality and County)

2500 Walden Ave, Town of Cheektowaga, Erie County

Name of Applicant/Sponsor Benderson Development Company, LLC

Address 570 Delaware Ave

City / PO Buffalo State NY Zip Code 14202

Business Telephone (716) 878 - 9626

Name of Owner (if different) Benderson Properties, Inc.

Address 570 Delaware Ave

City / PO Buffalo State NY Zip Code 14202

Business Telephone (716) 878-9626

Description of Action:

Rezone +/- 17.43 acres of the property located at 2500 Walden Ave. from M-1 Light Manufacturing to CM General Commercial in connection with the redevelopment of the property with a 185,000 s.f. retail building and associated improvements, including green space, landscaping, pavement, lighting and stormwater controls.

The site is located on the north side of Walden Avenue between Nagel Drive and Benbro Drive, east of the New York State Thruway. The site is bound to the east and west by a number of commercial developments and bound to the north by a residential development. Currently the site contains the 122,500 s.f. Super Flea on the north side of the property, an 80,500 s.f. warehouse building on the northeast corner of the property, a 3,500 s.f. outparcel containing a Manhattan Bagel on the south side of the property, a 32,000 s.f. ret building on the east side of the property, and a 30,000 s.f. vacant retail building on the west side of the property. The 80,500 s.f. buildi and the 3,500 s.f. outparcel are to remain, but all other buildings (184,500 s.f.) will be razed and a new 185,000 s.f. retail building is proposed.

The site is currently accessed by 5 stop controlled access points on Walden Ave. Three of the 5 existing access points are proposed to remain: the eastern-most driveway, the western-most driveway and the middle driveway. For the purpose of the rezone, the concept pl depicts a proposed traffic signal located at the center driveway so that the impacts of a proposed signal may be analyzed. The exact location of the signal (east, west or center drive) will be determined at the site plan review. The project will result in a significant increase to the buffer and setback for the residential properties to the north with the addition of a 50' wide planted buffer utilizing ben Colorado spruces and a board-on-board fence.

Attachment: notice of determination (RES-2011-631 : Negative SEQR Determination - 2480,2490-2550 Wald)

Please Complete Each Question--Indicate N.A. if not applicable

A. SITE DESCRIPTION

Physical setting of overall project, both developed and undeveloped areas.

- 1. Present Land Use: Urban Industrial Commercial Residential (suburban) Rural (non-farm)
- Forest Agriculture Other _____

2. Total acreage of project area: 22.35 +/- acres.

APPROXIMATE ACREAGE	PRESENTLY	AFTER COMPLETION
Meadow or Brushland (Non-agricultural)	<u>0</u> acres	<u>0</u> acres
Forested	<u>0</u> acres	<u>0</u> acres
Agricultural (Includes orchards, cropland, pasture, etc.)	<u>0</u> acres	<u>0</u> acres
Wetland (Freshwater or tidal as per Articles 24,25 of ECL)	<u>0</u> acres	<u>0</u> acres
Water Surface Area	<u>0</u> acres	<u>0</u> acres
Unvegetated (Rock, earth or fill)	<u>0</u> acres	<u>0</u> acres
Roads, buildings and other paved surfaces	<u>20.269</u> acres	<u>19.349</u> acres
Other (Indicate type) <u>Greenspace</u>	<u>2.08</u> acres	<u>3.00</u> acres

3. What is predominant soil type(s) on project site? La - Lakemont Silt loam

- a. Soil drainage: Well drained ____% of site Moderately well drained ____% of site.
- Poorly drained 100 % of site

b. If any agricultural land is involved, how many acres of soil are classified within soil group 1 through 4 of the NYS Land Classification System? 0 acres (see 1 NYCRR 370).

4. Are there bedrock outcroppings on project site? Yes No

a. What is depth to bedrock > 6 feet (in feet)

5. Approximate percentage of proposed project site with slopes:

- 0-10% 100 % 10- 15% ____ % 15% or greater ____ %

6. Is project substantially contiguous to, or contain a building, site, or district, listed on the State or National Registers of Historic Places? Yes No NYSHPO Map attached as Appendix I

7. Is project substantially contiguous to a site listed on the Register of National Natural Landmarks? Yes No

8. What is the depth of the water table? 0.5 to 1.5 (in feet)

9. Is site located over a primary, principal, or sole source aquifer? Yes No

10. Do hunting, fishing or shell fishing opportunities presently exist in the project area? Yes No

Attachment: notice of determination (RES-2011-631 : Negative SEQR Determination - 2480,2490-2550 Wald)

11. Does project site contain any species of plant or animal life that is identified as threatened or endangered? Yes No

According to:

Identify each species:

12. Are there any unique or unusual land forms on the project site? (i.e., cliffs, dunes, other geological formations?)
 Yes No

Describe:

13. Is the project site presently used by the community or neighborhood as an open space or recreation area?
 Yes No

If yes, explain:

14. Does the present site include scenic views known to be important to the community? Yes No

15. Streams within or contiguous to project area:

N/A

a. Name of Stream and name of River to which it is tributary

N/A

16. Lakes, ponds, wetland areas within or contiguous to project area:

Stormwater retention pond

b. Size (in acres):

N/A

Attachment: notice of determination (RES-2011-631 : Negative SEQR Determination - 2480,2490-2550 Wald)

- 17. Is the site served by existing public utilities? Yes No
 - a. If YES, does sufficient capacity exist to allow connection? Yes No
 - b. If YES, will improvements be necessary to allow connection? Yes No
- 18. Is the site located in an agricultural district certified pursuant to Agriculture and Markets Law, Article 25-AA, Section 303 and 304? Yes No
- 19. Is the site located in or substantially contiguous to a Critical Environmental Area designated pursuant to Article 8 of the ECL, and 6 NYCRR 617? Yes No

20. Has the site ever been used for the disposal of solid or hazardous wastes? Yes No

B. Project Description

- 1. Physical dimensions and scale of project (fill in dimensions as appropriate).
 - a. Total contiguous acreage owned or controlled by project sponsor: 22.349 acres.
 - b. Project acreage to be developed: 22.349 acres initially; 22.349 acres ultimately.
 - c. Project acreage to remain undeveloped: 0 acres.
 - d. Length of project, in miles: N/A (if appropriate)
 - e. If the project is an expansion, indicate percent of expansion proposed. N/A %
 - f. Number of off-street parking spaces existing 900 ; proposed 1133
 - g. Maximum vehicular trips generated per hour: 1278 (upon completion of project)?
 - h. If residential: Number and type of housing units:

Traffic Impact Study attached as Appendix A.

	One Family	Two Family	Multiple Family	Condominium
Initially	_____	_____	_____	_____
Ultimately	_____	_____	_____	_____

- i. Dimensions (in feet) of largest proposed structure: 40' +/- height; 350' +/- width; 600' +/- length.
- j. Linear feet of frontage along a public thoroughfare project will occupy is? 837.63' ft.

- 2. How much natural material (i.e. rock, earth, etc.) will be removed from the site? 0 tons/cubic yards.
- 3. Will disturbed areas be reclaimed Yes No N/A

a. If yes, for what intended purpose is the site being reclaimed?
 Landscaping

- b. Will topsoil be stockpiled for reclamation? Yes No
- c. Will upper subsoil be stockpiled for reclamation? Yes No
- 4. How many acres of vegetation (trees, shrubs, ground covers) will be removed from site? 0 acres.

Attachment: notice of determination (RES-2011-631 : Negative SEQOR Determination - 2480,2490-2550 Wald)

5. Will any mature forest (over 100 years old) or other locally-important vegetation be removed by this project?

Yes No

6. If single phase project: Anticipated period of construction: 12 months, (including demolition)

7. If multi-phased:

- a. Total number of phases anticipated N/A (number)
- b. Anticipated date of commencement phase 1: N/A month N/A year, (including demolition)
- c. Approximate completion date of final phase: N/A month N/A year.
- d. Is phase 1 functionally dependent on subsequent phases? Yes No

8. Will blasting occur during construction? Yes No

9. Number of jobs generated: during construction 200 +/- ; after project is complete 350 +/-

10. Number of jobs eliminated by this project 0

11. Will project require relocation of any projects or facilities? Yes No

If yes, explain:

12. Is surface liquid waste disposal involved? Yes No

a. If yes, indicate type of waste (sewage, industrial, etc) and amount Sanitary Sewage; 18,500 GPD

b. Name of water body into which effluent will be discharged Niagara River

13. Is subsurface liquid waste disposal involved? Yes No Type _____

14. Will surface area of an existing water body increase or decrease by proposal? Yes No

If yes, explain:

15. Is project or any portion of project located in a 100 year flood plain? Yes No FEMA Map attached as Appendix D

16. Will the project generate solid waste? Yes No

a. If yes, what is the amount per month? 2 tons

b. If yes, will an existing solid waste facility be used? Yes No

c. If yes, give name TBD; NYSDEC Approved ; location TBD

d. Will any wastes not go into a sewage disposal system or into a sanitary landfill? Yes No

Attachment: notice of determination (RES-2011-631 : Negative SEQR Determination - 2480,2490-2550 Wald)

e. If yes, explain:

17. Will the project involve the disposal of solid waste? Yes No

a. If yes, what is the anticipated rate of disposal? N/A tons/month.

b. If yes, what is the anticipated site life? N/A years.

18. Will project use herbicides or pesticides? Yes No

19. Will project routinely produce odors (more than one hour per day)? Yes No

20. Will project produce operating noise exceeding the local ambient noise levels? Yes No

21. Will project result in an increase in energy use? Yes No

Noise Impact Assessment attached as Appendix B.

If yes, indicate type(s)

Electric and Natural Gas

22. If water supply is from wells, indicate pumping capacity N/A gallons/minute.

23. Total anticipated water usage per day 20,350 gallons/day.

24. Does project involve Local, State or Federal funding? Yes No

If yes, explain:

Attachment: notice of determination (RES-2011-631 : Negative SEQR Determination - 2480,2490-2550 Wald)

25. Approvals Required:

			Type	Submittal Date
City, Town, Village Board	<input checked="" type="checkbox"/> Yes	<input type="checkbox"/> No	<u>Cheektowaga Town</u> <u>Board - Rezoning, Site Plan</u> <u>Approval & Subdivision</u>	<u>Rezone - 12/10</u> <u>Site Plan & Sub</u> <u>- TBD</u>
City, Town, Village Planning Board	<input checked="" type="checkbox"/> Yes	<input type="checkbox"/> No	<u>Planning Board- Rezoning,</u> <u>Site Plan & Subdivision</u> <u>Referral</u>	<u>Rezone - 12/10</u> <u>Site Plan & Sub</u> <u>- TBD</u>
City, Town Zoning Board	<input checked="" type="checkbox"/> Yes	<input type="checkbox"/> No	<u>Potential for area variances</u>	<u>TBD</u>
City, County Health Department	<input type="checkbox"/> Yes	<input checked="" type="checkbox"/> No		
Other Local Agencies	<input checked="" type="checkbox"/> Yes	<input type="checkbox"/> No	<u>Erie County Water</u> <u>Authority - Backflow</u> <u>Erie County Sewer Auth. -</u> <u>sewer tap</u>	<u>TBD</u>
Other Regional Agencies	<input type="checkbox"/> Yes	<input checked="" type="checkbox"/> No		
State Agencies	<input checked="" type="checkbox"/> Yes	<input type="checkbox"/> No	<u>New York State DOT</u>	<u>TBD</u>
Federal Agencies	<input type="checkbox"/> Yes	<input checked="" type="checkbox"/> No		

Attachment: notice of determination (RES-2011-631 : Negative SEQR Determination - 2480,2490-2550 Wald)

C. Zoning and Planning Information

1. Does proposed action involve a planning or zoning decision? Yes No

If Yes, indicate decision required:

- | | | | |
|--|---|--|--|
| <input checked="" type="checkbox"/> Zoning amendment | <input checked="" type="checkbox"/> Zoning variance | <input type="checkbox"/> New/revision of master plan | <input checked="" type="checkbox"/> Subdivisor |
| <input checked="" type="checkbox"/> Site plan | <input type="checkbox"/> Special use permit | <input type="checkbox"/> Resource management plan | <input type="checkbox"/> Other |

2. What is the zoning classification(s) of the site?

M1

3. What is the maximum potential development of the site if developed as permitted by the present zoning?

Undetermined. The M-1 district does not provide for a maximum lot coverage as part of the zoning code and parking is only required for employee's. Based upon this, a warehouse facility in excess of 500,000 SF could be built, if had a limited number of employees.

4. What is the proposed zoning of the site?

CM

5. What is the maximum potential development of the site if developed as permitted by the proposed zoning?

As shown on the provided site plan

6. Is the proposed action consistent with the recommended uses in adopted local land use plans? Yes No

7. What are the predominant land use(s) and zoning classifications within a ¼ mile radius of proposed action?

The predominate land use is commercial, office, warehouse and residential. The property is currently a legal, non-conforming retail plaza that is located on the major commercial strip within the Town of Cheektowaga. It is located across the street from and adjacent to other commercial uses (including retail, office and warehouse). In addition, the property is bordered in the north side by an existing residential neighborhood.

8. Is the proposed action compatible with adjoining/surrounding land uses with a ¼ mile? Yes No

9. If the proposed action is the subdivision of land, how many lots are proposed? Potential for 3 lot sub.

a. What is the minimum lot size proposed? +/- 1 acre

Attachment: notice of determination (RES-2011-631 : Negative SEQR Determination - 2480,2490-2550 Wald)

10. Will proposed action require any authorization(s) for the formation of sewer or water districts? Yes No

[Empty text box]

11. Will the proposed action create a demand for any community provided services (recreation, education, police, fire protection)?

Yes No

a. If yes, is existing capacity sufficient to handle projected demand? Yes No

[Empty text box]

12. Will the proposed action result in the generation of traffic significantly above present levels? Yes No

a. If yes, is the existing road network adequate to handle the additional traffic. Yes No See Traffic Impact Appendix A.

N/A

D. Informational Details

Attach any additional information as may be needed to clarify your project. If there are or may be any adverse impacts associated with your proposal, please discuss such impacts and the measures which you propose to mitigate or avoid them.

E. Verification

I certify that the information provided above is true to the best of my knowledge.

Applicant/Sponsor Name James A. Boglioli, Esq. Date 04/13/11

Signature 

Title Director, Right to Build - Northeast US

If the action is in the Coastal Area, and you are a state agency, complete the Coastal Assessment Form before proceeding with this assessment.

Attachment: notice of determination (RES-2011-631 : Negative SEQR Determination - 2480,2490-2550 Wald)

PART 2 - PROJECT IMPACTS AND THEIR MAGNITUDE

Responsibility of Lead Agency

General Information (Read Carefully)

- ! In completing the form the reviewer should be guided by the question: Have my responses and determinations been **reasonable?** The reviewer is not expected to be an expert environmental analyst.
- ! The **Examples** provided are to assist the reviewer by showing types of impacts and wherever possible the threshold of magnitude that would trigger a response in column 2. The examples are generally applicable throughout the State and for most situations. But, for any specific project or site other examples and/or lower thresholds may be appropriate for a Potential Large Impact response, thus requiring evaluation in Part 3.
- ! The impacts of each project, on each site, in each locality, will vary. Therefore, the examples are illustrative and have been offered as guidance. They do not constitute an exhaustive list of impacts and thresholds to answer each question.
- ! The number of examples per question does not indicate the importance of each question.
- ! In identifying impacts, consider long term, short term and cumulative effects.

Instructions (Read carefully)

- a. Answer each of the 20 questions in PART 2. Answer **Yes** if there will be **any** impact.
- b. **Maybe** answers should be considered as **Yes** answers.
- c. If answering **Yes** to a question then check the appropriate box(column 1 or 2)to indicate the potential size of the impact. If impact threshold equals or exceeds any example provided, check column 2. If impact will occur but threshold is lower than example, check column 1.
- d. Identifying that an Impact will be potentially large (column 2) does not mean that it is also necessarily **significant**. Any large impact must be evaluated in PART 3 to determine significance. Identifying an impact in column 2 simply asks that it be looked at further.
- e. If reviewer has doubt about size of the impact then consider the impact as potentially large and proceed to PART 3.
- f. If a potentially large impact checked in column 2 can be mitigated by change(s) in the project to a small to moderate impact, also check the **Yes** box in column 3. A **No** response indicates that such a reduction is not possible. This must be explained in Part 3.

1	2	3
Small to Moderate Impact	Potential Large Impact	Can Impact Be Mitigated by Project Change

Impact on Land

1. Will the Proposed Action result in a physical change to the project site?

NO YES

Examples that would apply to column 2

<ul style="list-style-type: none"> • Any construction on slopes of 15% or greater, (15 foot rise per 100 foot of length), or where the general slopes in the project area exceed 10%. • Construction on land where the depth to the water table is less than 3 feet. • Construction of paved parking area for 1,000 or more vehicles. • Construction on land where bedrock is exposed or generally within 3 feet of existing ground surface. • Construction that will continue for more than 1 year or involve more than one phase or stage. • Excavation for mining purposes that would remove more than 1,000 tons of natural material (i.e., rock or soil) per year. 	<input type="checkbox"/> <input checked="" type="checkbox"/> <input type="checkbox"/> <input type="checkbox"/> <input type="checkbox"/>	<input type="checkbox"/> <input type="checkbox"/> <input type="checkbox"/> <input type="checkbox"/>	<input type="checkbox"/> Yes <input type="checkbox"/> No <input type="checkbox"/> Yes <input type="checkbox"/> No <input type="checkbox"/> Yes <input type="checkbox"/> No <input type="checkbox"/> Yes <input type="checkbox"/> No <input type="checkbox"/> Yes <input type="checkbox"/> No
---	---	--	--

Attachment: notice of determination (RES-2011-631 : Negative SEQR Determination - 2480,2490-2550 Wald)

	1	2	3	
	Small to Moderate Impact	Potential Large Impact	Can Impact Be Mitigated by Project Change	

- Construction or expansion of a sanitary landfill. Yes No
- Construction in a designated floodway. Yes No
- Other impacts: Yes No

2. Will there be an effect to any unique or unusual land forms found on the site? (i.e., cliffs, dunes, geological formations, etc.)

NO YES

- Specific land forms: Yes No

Impact on Water

3. Will Proposed Action affect any water body designated as protected? (Under Articles 15, 24, 25 of the Environmental Conservation Law, ECL)

NO YES

Examples that would apply to column 2

- Developable area of site contains a protected water body. Yes No
- Dredging more than 100 cubic yards of material from channel of a protected stream. Yes No
- Extension of utility distribution facilities through a protected water body. Yes No
- Construction in a designated freshwater or tidal wetland. Yes No
- Other impacts: Yes No

4. Will Proposed Action affect any non-protected existing or new body of water?

NO YES

Examples that would apply to column 2

- A 10% increase or decrease in the surface area of any body of water or more than a 10 acre increase or decrease. Yes No
- Construction of a body of water that exceeds 10 acres of surface area. Yes No
- Other impacts: Yes No

Attachment: notice of determination (RES-2011-631 : Negative SEQR Determination - 2480,2490-2550 Wald)

1
Small to
Moderate
Impact

2
Potential
Large
Impact

3
Can Impact Be
Mitigated by
Project Change

5. Will Proposed Action affect surface or groundwater quality or quantity?

NO YES

Examples that would apply to column 2

- Proposed Action will require a discharge permit. Yes No
- Proposed Action requires use of a source of water that does not have approval to serve proposed (project) action. Yes No
- Proposed Action requires water supply from wells with greater than 45 gallons per minute pumping capacity. Yes No
- Construction or operation causing any contamination of a water supply system. Yes No
- Proposed Action will adversely affect groundwater. Yes No
- Liquid effluent will be conveyed off the site to facilities which presently do not exist or have inadequate capacity. Yes No
- Proposed Action would use water in excess of 20,000 gallons per day. Yes No
- Proposed Action will likely cause siltation or other discharge into an existing body of water to the extent that there will be an obvious visual contrast to natural conditions. Yes No
- Proposed Action will require the storage of petroleum or chemical products greater than 1,100 gallons. Yes No
- Proposed Action will allow residential uses in areas without water and/or sewer services. Yes No
- Proposed Action locates commercial and/or industrial uses which may require new or expansion of existing waste treatment and/or storage facilities. Yes No
- Other impacts: Yes No

Beneficial impacts are anticipated as a result of managed surface water quantity and improved water quality as required by the Tow's local law for Storm Water Pollution Prevention - Chapter 209 of the Cheektowaga Town Code

Attachment: notice of determination (RES-2011-631 : Negative SEQR Determination - 2480,2490-2550 Wald)

1	2	3
Small to Moderate Impact	Potential Large Impact	Can Impact Be Mitigated by Project Change

6. Will Proposed Action alter drainage flow or patterns, or surface water runoff?
 NO YES

Examples that would apply to column 2

- | | | | | |
|--|-------------------------------------|--------------------------|------------------------------|-----------------------------|
| • Proposed Action would change flood water flows | <input type="checkbox"/> | <input type="checkbox"/> | <input type="checkbox"/> Yes | <input type="checkbox"/> No |
| • Proposed Action may cause substantial erosion. | <input type="checkbox"/> | <input type="checkbox"/> | <input type="checkbox"/> Yes | <input type="checkbox"/> No |
| • Proposed Action is incompatible with existing drainage patterns. | <input type="checkbox"/> | <input type="checkbox"/> | <input type="checkbox"/> Yes | <input type="checkbox"/> No |
| • Proposed Action will allow development in a designated floodway. | <input type="checkbox"/> | <input type="checkbox"/> | <input type="checkbox"/> Yes | <input type="checkbox"/> No |
| • Other impacts: | <input checked="" type="checkbox"/> | <input type="checkbox"/> | <input type="checkbox"/> Yes | <input type="checkbox"/> No |

Beneficial impacts see response to question number 5.

IMPACT ON AIR

7. Will Proposed Action affect air quality?
 NO YES

Examples that would apply to column 2

- | | | | | |
|---|-------------------------------------|--------------------------|------------------------------|-----------------------------|
| • Proposed Action will induce 1,000 or more vehicle trips in any given hour. | <input checked="" type="checkbox"/> | <input type="checkbox"/> | <input type="checkbox"/> Yes | <input type="checkbox"/> No |
| • Proposed Action will result in the incineration of more than 1 ton of refuse per hour. | <input type="checkbox"/> | <input type="checkbox"/> | <input type="checkbox"/> Yes | <input type="checkbox"/> No |
| • Emission rate of total contaminants will exceed 5 lbs. per hour or a heat source producing more than 10 million BTU's per hour. | <input type="checkbox"/> | <input type="checkbox"/> | <input type="checkbox"/> Yes | <input type="checkbox"/> No |
| • Proposed Action will allow an increase in the amount of land committed to industrial use. | <input type="checkbox"/> | <input type="checkbox"/> | <input type="checkbox"/> Yes | <input type="checkbox"/> No |
| • Proposed Action will allow an increase in the density of industrial development within existing industrial areas. | <input type="checkbox"/> | <input type="checkbox"/> | <input type="checkbox"/> Yes | <input type="checkbox"/> No |
| • Other impacts: | <input type="checkbox"/> | <input type="checkbox"/> | <input type="checkbox"/> Yes | <input type="checkbox"/> No |

IMPACT ON PLANTS AND ANIMALS

8. Will Proposed Action affect any threatened or endangered species?
 NO YES

Examples that would apply to column 2

- | | | | | |
|---|--------------------------|--------------------------|------------------------------|-----------------------------|
| • Reduction of one or more species listed on the New York or Federal list, using the site, over or near the site, or found on the site. | <input type="checkbox"/> | <input type="checkbox"/> | <input type="checkbox"/> Yes | <input type="checkbox"/> No |
|---|--------------------------|--------------------------|------------------------------|-----------------------------|

Attachment: notice of determination (RES-2011-631 : Negative SEQR Determination - 2480,2490-2550 Wald)

	1 Small to Moderate Impact	2 Potential Large Impact	3 Can Impact Be Mitigated by Project Change
• Removal of any portion of a critical or significant wildlife habitat.	<input type="checkbox"/>	<input type="checkbox"/>	<input type="checkbox"/> Yes <input type="checkbox"/> No
• Application of pesticide or herbicide more than twice a year, other than for agricultural purposes.	<input type="checkbox"/>	<input type="checkbox"/>	<input type="checkbox"/> Yes <input type="checkbox"/> No
• Other impacts:	<input type="checkbox"/>	<input type="checkbox"/>	<input type="checkbox"/> Yes <input type="checkbox"/> No

9. Will Proposed Action substantially affect non-threatened or non-endangered species?

NO YES

Examples that would apply to column 2

• Proposed Action would substantially interfere with any resident or migratory fish, shellfish or wildlife species.	<input type="checkbox"/>	<input type="checkbox"/>	<input type="checkbox"/> Yes <input type="checkbox"/> No
• Proposed Action requires the removal of more than 10 acres of mature forest (over 100 years of age) or other locally important vegetation.	<input type="checkbox"/>	<input type="checkbox"/>	<input type="checkbox"/> Yes <input type="checkbox"/> No
• Other impacts:	<input type="checkbox"/>	<input type="checkbox"/>	<input type="checkbox"/> Yes <input type="checkbox"/> No

IMPACT ON AGRICULTURAL LAND RESOURCES

10. Will Proposed Action affect agricultural land resources?

NO YES

Examples that would apply to column 2

• The Proposed Action would sever, cross or limit access to agricultural land (includes cropland, hayfields, pasture, vineyard, orchard, etc.)	<input type="checkbox"/>	<input type="checkbox"/>	<input type="checkbox"/> Yes <input type="checkbox"/> No
• Construction activity would excavate or compact the soil profile of agricultural land.	<input type="checkbox"/>	<input type="checkbox"/>	<input type="checkbox"/> Yes <input type="checkbox"/> No
• The Proposed Action would irreversibly convert more than 10 acres of agricultural land or, if located in an Agricultural District, more than 2.5 acres of agricultural land.	<input type="checkbox"/>	<input type="checkbox"/>	<input type="checkbox"/> Yes <input type="checkbox"/> No

	1 Small to Moderate Impact	2 Potential Large Impact	3 Can Impact Be Mitigated by Project Change
• The Proposed Action would disrupt or prevent installation of agricultural land management systems (e.g., subsurface drain lines, outlet ditches, strip cropping); or create a need for such measures (e.g. cause a farm field to drain poorly due to increased runoff).	<input type="checkbox"/>	<input type="checkbox"/>	<input type="checkbox"/> Yes <input type="checkbox"/> No
• Other impacts:	<input type="checkbox"/>	<input type="checkbox"/>	<input type="checkbox"/> Yes <input type="checkbox"/> No

IMPACT ON AESTHETIC RESOURCES

11. Will Proposed Action affect aesthetic resources? (If necessary, use the Visual EAF Addendum in Section 617.20, Appendix B.)

NO YES

Examples that would apply to column 2

• Proposed land uses, or project components obviously different from or in sharp contrast to current surrounding land use patterns, whether man-made or natural.	<input type="checkbox"/>	<input type="checkbox"/>	<input type="checkbox"/> Yes <input type="checkbox"/> No
• Proposed land uses, or project components visible to users of aesthetic resources which will eliminate or significantly reduce their enjoyment of the aesthetic qualities of that resource.	<input type="checkbox"/>	<input type="checkbox"/>	<input type="checkbox"/> Yes <input type="checkbox"/> No
• Project components that will result in the elimination or significant screening of scenic views known to be important to the area.	<input type="checkbox"/>	<input type="checkbox"/>	<input type="checkbox"/> Yes <input type="checkbox"/> No
• Other impacts:	<input type="checkbox"/>	<input type="checkbox"/>	<input type="checkbox"/> Yes <input type="checkbox"/> No

IMPACT ON HISTORIC AND ARCHAEOLOGICAL RESOURCES

12. Will Proposed Action impact any site or structure of historic, prehistoric or paleontological importance?

NO YES

Examples that would apply to column 2

• Proposed Action occurring wholly or partially within or substantially contiguous to any facility or site listed on the State or National Register of historic places.	<input type="checkbox"/>	<input type="checkbox"/>	<input type="checkbox"/> Yes <input type="checkbox"/> No
• Any impact to an archaeological site or fossil bed located within the project site.	<input type="checkbox"/>	<input type="checkbox"/>	<input type="checkbox"/> Yes <input type="checkbox"/> No
• Proposed Action will occur in an area designated as sensitive for archaeological sites on the NYS Site Inventory.	<input type="checkbox"/>	<input type="checkbox"/>	<input type="checkbox"/> Yes <input type="checkbox"/> No

	1	2	3
	Small to Moderate Impact	Potential Large Impact	Can Impact Be Mitigated by Project Change

• Other impacts:

 Yes No

IMPACT ON OPEN SPACE AND RECREATION

13. Will proposed Action affect the quantity or quality of existing or future open spaces or recreational opportunities?

 NO YES

Examples that would apply to column 2

• The permanent foreclosure of a future recreational opportunity.

 Yes No

• A major reduction of an open space important to the community.

 Yes No

• Other impacts:

 Yes No

IMPACT ON CRITICAL ENVIRONMENTAL AREAS

14. Will Proposed Action impact the exceptional or unique characteristics of a critical environmental area (CEA) established pursuant to subdivision 6NYCRR 617.14(g)?

 NO YES

List the environmental characteristics that caused the designation of the CEA.

Examples that would apply to column 2

• Proposed Action to locate within the CEA?

 Yes No

• Proposed Action will result in a reduction in the quantity of the resource?

 Yes No

• Proposed Action will result in a reduction in the quality of the resource?

 Yes No

• Proposed Action will impact the use, function or enjoyment of the resource?

 Yes No

• Other impacts:

 Yes No

Attachment: notice of determination (RES-2011-631 : Negative SEQR Determination - 2480,2490-2550 Wald)

1	2	3	
Small to Moderate Impact	Potential Large Impact	Can Impact Be Mitigated by Project Change	

IMPACT ON TRANSPORTATION

15. Will there be an effect to existing transportation systems?

NO YES

Examples that would apply to column 2

- | | | | | |
|--|-------------------------------------|--------------------------|------------------------------|-----------------------------|
| • Alteration of present patterns of movement of people and/or goods. | <input checked="" type="checkbox"/> | <input type="checkbox"/> | <input type="checkbox"/> Yes | <input type="checkbox"/> No |
| • Proposed Action will result in major traffic problems. | <input type="checkbox"/> | <input type="checkbox"/> | <input type="checkbox"/> Yes | <input type="checkbox"/> No |
| • Other impacts: | <input type="checkbox"/> | <input type="checkbox"/> | <input type="checkbox"/> Yes | <input type="checkbox"/> No |

IMPACT ON ENERGY

16. Will Proposed Action affect the community's sources of fuel or energy supply?

NO YES

Examples that would apply to column 2

- | | | | | |
|---|--------------------------|--------------------------|------------------------------|-----------------------------|
| • Proposed Action will cause a greater than 5% increase in the use of any form of energy in the municipality. | <input type="checkbox"/> | <input type="checkbox"/> | <input type="checkbox"/> Yes | <input type="checkbox"/> No |
| • Proposed Action will require the creation or extension of an energy transmission or supply system to serve more than 50 single or two family residences or to serve a major commercial or industrial use. | <input type="checkbox"/> | <input type="checkbox"/> | <input type="checkbox"/> Yes | <input type="checkbox"/> No |
| • Other impacts: | <input type="checkbox"/> | <input type="checkbox"/> | <input type="checkbox"/> Yes | <input type="checkbox"/> No |

NOISE AND ODOR IMPACT

17. Will there be objectionable odors, noise, or vibration as a result of the Proposed Action?

NO YES

Examples that would apply to column 2

- | | | | | |
|--|--------------------------|--------------------------|------------------------------|-----------------------------|
| • Blasting within 1,500 feet of a hospital, school or other sensitive facility. | <input type="checkbox"/> | <input type="checkbox"/> | <input type="checkbox"/> Yes | <input type="checkbox"/> No |
| • Odors will occur routinely (more than one hour per day). | <input type="checkbox"/> | <input type="checkbox"/> | <input type="checkbox"/> Yes | <input type="checkbox"/> No |
| • Proposed Action will produce operating noise exceeding the local ambient noise levels for noise outside of structures. | <input type="checkbox"/> | <input type="checkbox"/> | <input type="checkbox"/> Yes | <input type="checkbox"/> No |
| • Proposed Action will remove natural barriers that would act as a noise screen. | <input type="checkbox"/> | <input type="checkbox"/> | <input type="checkbox"/> Yes | <input type="checkbox"/> No |
| • Other impacts: | <input type="checkbox"/> | <input type="checkbox"/> | <input type="checkbox"/> Yes | <input type="checkbox"/> No |

Attachment: notice of determination (RES-2011-631 : Negative SEQR Determination - 2480,2490-2550 Wald)

1
Small to
Moderate
Impact

2
Potential
Large
Impact

3
Can Impact Be
Mitigated by
Project Change

IMPACT ON PUBLIC HEALTH

18. Will Proposed Action affect public health and safety?
 NO YES

- Proposed Action may cause a risk of explosion or release of hazardous substances (i.e. oil, pesticides, chemicals, radiation, etc.) in the event of accident or upset conditions, or there may be a chronic low level discharge or emission. Yes No
- Proposed Action may result in the burial of "hazardous wastes" in any form (i.e. toxic, poisonous, highly reactive, radioactive, irritating, infectious, etc.) Yes No
- Storage facilities for one million or more gallons of liquefied natural gas or other flammable liquids. Yes No
- Proposed Action may result in the excavation or other disturbance within 2,000 feet of a site used for the disposal of solid or hazardous waste. Yes No
- Other impacts: Yes No

IMPACT ON GROWTH AND CHARACTER OF COMMUNITY OR NEIGHBORHOOD

19. Will Proposed Action affect the character of the existing community?
 NO YES

- Examples** that would apply to column 2
- The permanent population of the city, town or village in which the project is located is likely to grow by more than 5%. Yes No
 - The municipal budget for capital expenditures or operating services will increase by more than 5% per year as a result of this project. Yes No
 - Proposed Action will conflict with officially adopted plans or goals. Yes No
 - Proposed Action will cause a change in the density of land use. Yes No
 - Proposed Action will replace or eliminate existing facilities, structures or areas of historic importance to the community. Yes No
 - Development will create a demand for additional community services (e.g. schools, police and fire, etc.) Yes No

Attachment: notice of determination (RES-2011-631 : Negative SEQR Determination - 2480,2490-2550 Wald)

	1 Small to Moderate Impact	2 Potential Large Impact	3 Can Impact Be Mitigated by Project Change
• Proposed Action will set an important precedent for future projects.	<input type="checkbox"/>	<input type="checkbox"/>	<input type="checkbox"/> Yes <input type="checkbox"/> No
• Proposed Action will create or eliminate employment.	<input type="checkbox"/>	<input type="checkbox"/>	<input type="checkbox"/> Yes <input type="checkbox"/> No
• Other impacts:	<input checked="" type="checkbox"/>	<input type="checkbox"/>	<input type="checkbox"/> Yes <input type="checkbox"/> No

beneficial aesthetic benefits are anticipated with the future re-development of the subject site.

20. Is there, or is there likely to be, public controversy related to potential adverse environment impacts?
 NO YES

If Any Action in Part 2 Is Identified as a Potential Large Impact or If you Cannot Determine the Magnitude of Impact, Proceed to Part 3

Attachment: notice of determination (RES-2011-631 : Negative SEQR Determination - 2480,2490-2550 Wald)

Appendices to the Full Environmental Assessment Form

- Appendix A Traffic Impact Study, prepared by TY Lin International, dated April 8, 2011
- Appendix B Noise Impact Assessment, prepared by Angevine Consultants, Inc, dated March 30, 2011
- Appendix C Preliminary Stormwater Management Report, prepared by TY Lin International, dated March 2011
- Appendix D FIRM Flood Insurance Rate Map
- Appendix E NYSSHPO Map
- Appendix F Line of sight drawings and visual renderings

APPENDIX G - LIGHTING PHOTOMETRIC PLAN



Town of Cheektowaga

Work Session

~ Minutes ~

3301 Broadway
Cheektowaga, NY 14227
<http://www.town.cheektowaga.ny.us>

Alice Magierski
716-686-3400

Tuesday, December, 13, 2011

6:00 PM

Council Office

I. Call to Order

6:00 PM Meeting called to order on December 13, 2011 at Council Office, Conference Room, Cheektowaga, NY.

Attendee Name	Organization	Title	Status	Arrived
Mary Holtz	Town of Cheektowaga	Supervisor	Present	
Patricia Jaworowicz	Town of Cheektowaga	Councilmember	Absent	
Jeff Swiatek	Town of Cheektowaga	Councilmember	Absent	
James Rogowski	Town of Cheektowaga	Councilmember	Present	
Richard Zydel	Town of Cheektowaga	Councilmember	Present	
Charles Markel	Town of Cheektowaga	Councilmember	Present	
Stanley Kaznowski	Town of Cheektowaga	Councilmember	Present	

2. Additional Attendees

Brian Krause, Director of Finance and Administration
Anthony Romano, Coordinator of Employee Relations
Kevin Schenk, Town Attorney

II. Resolutions



1. RESOLUTION 2011-645

Notice to Bidders - One (1) New and Unused 2011 20' Scissor Lift

Sponsored By: Councilmember Rogowski, Councilmember Kaznowski

WHEREAS, by resolution dated November 21, 2011 (Resolution #2011-605), this Town Board authorized the receipt of bids for the purchase of a 2011 20' Scissor Lift, and said bids were duly received and opened on December 7, 2011, AND

WHEREAS, there is a need to revise the specifications for the Scissor Lift and re-bid same in order to bring the cost within the constraints of the budget available, NOW, THEREFORE, BE IT

RESOLVED, that the bids received on December 7, 2011 for said 2011 20' Scissor Lift be and hereby are rejected, AND, BE IT FURTHER

RESOLVED, that the Town Clerk be directed to publish a Notice to Bidders for the purchase of one (1) new and unused 2011 20' Scissor Lift (with revised specifications), said notice to be published in the CHEEKTOWAGA BEE, AND, BE IT FURTHER

RESOLVED, that sealed bids will be received and opened by the Town Clerk on the 21st day of December, 2011 at 11:00 am, at a public bid opening to be held in the Council Chambers at the Cheektowaga Town Hall.

NOTICE TO BIDDERS

Sealed proposals will be received by the Town of Cheektowaga on December 21, 2011 at the Town Hall, corner of Broadway and Union Road, for the purchase of one (1) new and unused 2011 20' Scissor Lift.

Information for bidders and specifications may be obtained from the Town Clerk at her office in said Town.

The Town Board reserves the right to consider informal any bid not prepared and submitted in accordance with the provisions of the specifications and contract documents, and may waive any informalities, make an award to other than the low bidder, should it be in the best interest of the Town, or reject any or all bids.

By order of the Town Board of the Town of Cheektowaga, Erie County, New York.

Alice Magierski
Town Clerk

DATED: December 13, 2011

RESULT:	ADOPTED [UNANIMOUS]
MOVER:	James Rogowski, Councilmember
SECONDER:	Stanley Kaznowski, Councilmember
AYES:	Holtz, Rogowski, Zydel, Markel, Kaznowski
ABSENT:	Patricia Jaworowicz, Jeff Swiatek



Town of Cheektowaga

Regular Meeting

~ Minutes ~

3301 Broadway
Cheektowaga, NY 14227

<http://www.town.cheektowaga.ny.us>

Alice Magierski
716-686-3400

Monday, December 19, 2011

6:45 PM

Council Chambers

I. Call to Order

6:45 PM Meeting called to order on December 19, 2011 at Council Chambers, 3301 Broadway St, Cheektowaga, NY.

Attendee Name	Organization	Title	Status	Arrived
Mary Holtz	Town of Cheektowaga	Supervisor	Present	
Patricia Jaworowicz	Town of Cheektowaga	Councilmember	Present	
Jeff Swiatek	Town of Cheektowaga	Councilmember	Present	
James Rogowski	Town of Cheektowaga	Councilmember	Present	
Richard Zydel	Town of Cheektowaga	Councilmember	Present	
Charles Markel	Town of Cheektowaga	Councilmember	Present	
Stanley Kaznowski	Town of Cheektowaga	Councilmember	Present	

2. Additional Attendees

Thomas Adamczak, Supervising Building and Plumbing Inspector
Ellen Fischer, Executive Director - Youth Board
Brian Krause, Director of Finance and Administration
Earl Loder, Disaster Coordinator
John Marriott, Planning Board Chairman
William Pugh, Town Engineer
Anthony Romano, Coordinator of Employee Relations
Kevin Schenk, Town Attorney
David Zack, Chief of Police

II. Public Comment Period

III. Resolutions



1. RESOLUTION 2011-646

Transfer of Funds

Sponsored By: Supervisor Holtz, Councilmember Swiatek

BE IT RESOLVED, that the following transfer is hereby approved and made a part hereof;

GENERAL FUND

FROM:	100.7140.1971.1630	Part Time Regular	\$ 2,000.00
	100.7140.1971.1614	Part Time Regular	3,500.00
	100.7310.1971.1803	Part Time Regular	1,000.00
	100.7310.1971.1803	Part Time Regular	2,000.00
TO:	100.7140.1971.1611	Part Time Regular	\$ 2,000.00
	100.7140.1971.1639	Part Time Regular	3,500.00
	100.7310.1971.1804	Part Time Regular	1,000.00
	100.7310.1971.1814	Part Time Regular	2,000.00

HIGHWAY FUND

FROM:	300.5110.4186	Topsoil	\$ 2,000.00
	300.5141.1951	Seasonal	19,700.00
TO:	300.5140.4191	Misc. Expense	\$ 2,000.00
	300.5141.1902	Overtime	19,700.00

HUD CDBG FUND

FROM:	700.1010.0665	Sr. Citizen Van	\$18,000.00
TO:	700.1010.2431	Bathroom Facilities	\$18,000.00

RESULT:	ADOPTED [UNANIMOUS]
MOVER:	Mary Holtz, Supervisor
SECONDER:	Jeff Swiatek, Councilmember
AYES:	Holtz, Jaworowicz, Swiatek, Rogowski, Zydel, Markel, Kaznowski



2. RESOLUTION 2011-647

Warrant

Sponsored By: Supervisor Holtz, Councilmember Swiatek

BE IT RESOLVED, that the following Vouchers & Warrants submitted to the Town of Cheektowaga prior to December 16, 2011 are hereby approved and made a part hereof;

GENERAL FUND	\$	355,845.54
RISK RETENTION FUND		10,590.91
HUD HOUSING REHABILITATION FUND		4,394.00
SPECIAL DISTRICTS FUND		224,750.10
HIGHWAY FUND		14,538.50
CAPITAL FUND		897,502.72
TRUST & AGENCY FUND		16,252.83
HUD CDBG FUND		2,266.41
PART TOWN FUND		30,973.53
NYS AFFORDABLE HOUSING		5,328.00
		<u>\$ 1,562,442.54</u>

RESULT: **ADOPTED [UNANIMOUS]**

MOVER: Mary Holtz, Supervisor

SECONDER: Jeff Swiatek, Councilmember

AYES: Holtz, Jaworowicz, Swiatek, Rogowski, Zydel, Markel, Kaznowski



3. RESOLUTION 2011-648

Amended Notice to Bidders - One (1) New and Unused 2011 20' Scissor Lift

Sponsored By: Councilmember Rogowski, Councilmember Kaznowski

WHEREAS, by resolution dated November 21, 2011 (Resolution #2011-605), this Town Board authorized the receipt of bids for the purchase of a 2011 20' Scissor Lift, and said bids were duly received and opened on December 7, 2011, AND

WHEREAS, by resolution dated December 13, 2011 (Resolution #2011-645) this Town Board rejected the bids that were received on December 7, 2011 and issued a Notice to Bidders for the purchase of one (1) new and unused 2011 20' Scissor Lift (with revised specifications), AND

WHEREAS, said Notice to Bidders was inadvertently not published in the CHEEKTOWAGA BEE; as such, the date for opening of bid proposals needs to be extended so that the Notice to Bidders can be published in the CHEEKTOWAGA BEE, NOW, THEREFORE, BE IT

RESOLVED, that Resolution 2011-645 be and hereby is amended to provide that bids for the purchase of one (1) new and unused 2011 20' Scissor Lift shall be opened on the 28th day of December, 2011 at 11:00 am, at a public bid opening to be held by the Town Clerk in the Council Chambers at the Cheektowaga Town Hall, AND, BE IT FURTHER

RESOLVED, that the Town Clerk be directed to publish a Notice to Bidders for the purchase of one (1) new and unused 2011 20' Scissor Lift, said notice to be published in the CHEEKTOWAGA BEE, AND, BE IT FURTHER

RESOLVED, that sealed bids will be received and opened by the Town Clerk on the 28th day of December, 2011 at 11:00 am, at a public bid opening to be held in the Council Chambers at the Cheektowaga Town Hall.

NOTICE TO BIDDERS

Sealed proposals will be received by the Town of Cheektowaga on December 28, 2011 at the Town Hall, corner of Broadway and Union Road, for the purchase of one (1) new and unused 2011 20' Scissor Lift.

Information for bidders and specifications may be obtained from the Town Clerk at her office in said Town.

The Town Board reserves the right to consider informal any bid not prepared and submitted in accordance with the provisions of the specifications and contract documents, and may waive any informalities, make an award to other than the low bidder, should it be in the best interest of the Town, or reject any or all bids.

By order of the Town Board of the Town of Cheektowaga, Erie County, New York.

Alice Magierski
Town Clerk

DATED: December 19, 2011

RESULT:	ADOPTED [UNANIMOUS]
MOVER:	James Rogowski, Councilmember
SECONDER:	Stanley Kaznowski, Councilmember
AYES:	Holtz, Jaworowicz, Swiatek, Rogowski, Zydel, Markel, Kaznowski



4. RESOLUTION 2011-649

Amend Change Order for Demolition of 89 Gardenvale Drive

Sponsored By: Councilmember Markel, Councilmember Kaznowski

WHEREAS, by resolution dated December 5, 2011 (Resolution 2011-635), this Town Board approved a change order for AFI Environmental relating to the demolition of 89 Gardenvale Drive, and

WHEREAS, there was an error in the wording of the first "WHEREAS" clause of said resolution, NOW, THEREFORE, BE IT

RESOLVED, that the first "WHEREAS" clause of Resolution 2011-635 shall be amended to read as follows:

"WHEREAS, by resolution dated August 15, 2011 (Resolution 2011-450), this Town Board awarded a contract with Buffalo Environmental Consultants, Inc., d/b/a AFI Environmental for the demolition of 89 Gardenvale Drive, and"

RESULT:	ADOPTED [UNANIMOUS]
MOVER:	Charles Markel, Councilmember
SECONDER:	Stanley Kaznowski, Councilmember
AYES:	Holtz, Jaworowicz, Swiatek, Rogowski, Zydel, Markel, Kaznowski



5. RESOLUTION 2011-650

Award of Bid - Target System Firing Range

Sponsored By: Supervisor Holtz, Councilmember Rogowski

WHEREAS, by resolution dated November 7, 2011, the Town of Cheektowaga advertised for bids for the furnishing, delivery, and installation supervision for a Modular Bullet Trap/Containment System and Fixed Air Turning Target System Firing Range for the outdoor shooting range located on Scott Place, AND

WHEREAS, bids were received on November 23, 2011 at 11:00 am and Action Target submitted the sole bid for said system, AND

WHEREAS, opinions of the New York Comptroller enable the Town to further negotiate with the lowest responsible bidder in order to obtain a better price, AND

WHEREAS, representatives of the Town Police Department have negotiated with representatives of Action Target who has agreed to lower their bid to \$216,300.00 from the original bid amount of \$228,750.00 resulting in a savings to the Town, NOW, THEREFORE, BE IT

RESOLVED, that this Town Board hereby awards the bid for the furnishing of a Modular Bullet Trap/Containment System and Fixed Air Turning Target System Firing Range to:

Action Target
3411 South Mountain Vista Parkway
Provo, Utah 84606

for the negotiated bid price of \$216,300.00, chargeable to Account #600-0600-0881, Police Asset Forfeiture.

RESULT:	ADOPTED [UNANIMOUS]
MOVER:	Mary Holtz, Supervisor
SECONDER:	James Rogowski, Councilmember
AYES:	Holtz, Jaworowicz, Swiatek, Rogowski, Zydel, Markel, Kaznowski



6. RESOLUTION 2011-651

Award of Bid - 2012 Ford F-550 Truck with 12' Stake Body

Sponsored By: Councilmember Rogowski, Councilmember Kaznowski

WHEREAS, a Notice to Bidders was duly published for the receipt of bids for the furnishing of one (1) 2012 Ford F-550 Truck with 12' Stake Body for the Parks Division, which bids were duly received and opened at a public bid opening called for that purpose, AND

WHEREAS, said bids were referred to the Engineering Department for analysis, NOW, THEREFORE, BE IT

RESOLVED, that the contract for the furnishing of one (1) new and unused 2012 Ford F-550 Truck with 12' Stake Body be awarded to:

Basil Ford Inc.
1540 Walden Avenue
Cheektowaga, New York 14225

for their total bid in the amount of \$32,303.00, said bid being the lowest bid meeting the requirements of the specifications, AND, BE IT FURTHER

RESOLVED, that funds are available in Account #0100-7110-2303.

RESULT:	ADOPTED [UNANIMOUS]
MOVER:	James Rogowski, Councilmember
SECONDER:	Stanley Kaznowski, Councilmember
AYES:	Holtz, Jaworowicz, Swiatek, Rogowski, Zydel, Markel, Kaznowski



7. RESOLUTION 2011-652

Award of Bid - Street Light Standards

Sponsored By: Councilmember Kaznowski, Councilmember Zydel

WHEREAS, a Notice to Bidders was duly published for the receipt of bids for the purchase of round tapered aluminum street light standards with elliptical arms, which bids were duly opened on November 23, 2011, AND

WHEREAS, said bids were referred to the Town Engineer for analysis, tabulation and report, which is contained in a letter to the Town Board dated December 6, 2011, NOW, THEREFORE, BE IT

RESOLVED, that the bid for furnishing round tapered aluminum street light standards, to be purchased on an as needed basis during the period from January 1, 2012 to June 30, 2012, be and hereby is awarded to the lowest bidder meeting the requirements of the specifications as follows based on the unit price for various quantities as noted below:

<u>VENDOR</u>	<u>QUANTITY</u>	<u>UNIT PRICE</u>
Shanor Electric 285 Hinman Avenue Buffalo, NY 14216	(1)	\$1,177.00 ea.
Shanor Electric 285 Hinman Avenue Buffalo, NY 14216	(10)	\$1,177.00 ea.
Wesco 120 Galleria Drive Cheektowaga, NY 14225	(20)	\$1,170.00 ea.

RESULT:	ADOPTED [UNANIMOUS]
MOVER:	Stanley Kaznowski, Councilmember
SECONDER:	Richard Zydel, Councilmember
AYES:	Holtz, Jaworowicz, Swiatek, Rogowski, Zydel, Markel, Kaznowski



8. RESOLUTION 2011-653

Award of Bid: Portable Chemical Toilets 2012

Sponsored By: Councilmember Rogowski, Councilmember Kaznowski

WHEREAS, bid proposals were received for the Leasing and Servicing of Portable Chemical Toilets on December 14, 2011, AND

WHEREAS, said proposals have been reviewed for compliance under the terms of the specifications, NOW THEREFORE BE IT

RESOLVED, that the Cheektowaga Town Board hereby award said Bid for the Leasing and Servicing of Portable Chemical Toilets to:

Ball Toilet & Septic Services
P. O. Box 2072
Blasdell, New York 14219

Category A	-	Single Units	\$2.88 per day per unit Items I through X
Category B	-	Handicapped Units	\$4.95 per day per unit Items I and II
Category C	-	Special Events	\$62.20 per day per unit items I through VIII

RESULT:	ADOPTED [UNANIMOUS]
MOVER:	James Rogowski, Councilmember
SECONDER:	Stanley Kaznowski, Councilmember
AYES:	Holtz, Jaworowicz, Swiatek, Rogowski, Zydel, Markel, Kaznowski



9. RESOLUTION 2011-654

Establish Holidays for 2012

Sponsored By: Supervisor Holtz, Councilmember Markel

BE IT RESOLVED, that the following holidays shall be observed by the Town of Cheektowaga in 2012:

New Year's Day	January 2, 2012	Monday
Martin Luther King, Jr. Day	January 16, 2012	Monday
President's Day	February 20, 2012	Monday
Good Friday	April 6, 2012	Friday
Memorial Day	May 28, 2012	Monday
Independence Day	July 4, 2012	Wednesday
Labor Day	September 3, 2012	Monday
Columbus Day	October 8, 2012	Monday
Election Day	November 6, 2012	Tuesday
Veterans Day	November 12, 2012	Monday
Thanksgiving Day	November 22, 2012	Thursday
Day After Thanksgiving	November 23, 2012	Friday
Christmas Eve	December 24, 2012	Monday
Christmas Day	December 25, 2012	Tuesday

RESULT:	ADOPTED [UNANIMOUS]
MOVER:	Mary Holtz, Supervisor
SECONDER:	Charles Markel, Councilmember
AYES:	Holtz, Jaworowicz, Swiatek, Rogowski, Zydel, Markel, Kaznowski



10. RESOLUTION 2011-655

Establish Work Session Dates for 2012

Sponsored By: Supervisor Holtz, Councilmember Kaznowski

BE IT RESOLVED, that the Town Board of the Town of Cheektowaga shall hold work sessions for the calendar year 2012 at 6:00 P.M. on the following dates:

- January 10th, 31st
- February 14th, 28th
- March 13th, 27th
- April 10th
- May 1st, 15th
- June 12th, 26th
- July 10th, 31st
- August 14th, 28th
- September 11th, 25th
- October 9th, 30th
- November 13th, 27th
- December 11th, 26th

, and BE IT FURTHER

RESOLVED, that said work sessions shall be held in the Council Office Conference Room, Town Hall, 3301 Broadway, Cheektowaga, New York, and BE IT FURTHER

RESOLVED, that the Town Clerk be and hereby is directed to forward copies of this resolution to the Cheektowaga Bee, Buffalo News and the Metro Source, and BE IT FURTHER

RESOLVED, that the above Work Session dates shall be posted in the Town's website.

RESULT:	ADOPTED [UNANIMOUS]
MOVER:	Mary Holtz, Supervisor
SECONDER:	Stanley Kaznowski, Councilmember
AYES:	Holtz, Jaworowicz, Swiatek, Rogowski, Zydel, Markel, Kaznowski



11. RESOLUTION 2011-656

Establishment of Town Board Meeting Dates in 2012

Sponsored By: Supervisor Holtz, Councilmember Rogowski

BE IT RESOLVED, that regular meetings of the Town Board of the Town of Cheektowaga for the calendar year 2012 shall be held at 6:45 P.M. in the Council Chambers of the Town Hall, 3301 Broadway, Cheektowaga, New York on the following referenced dates:

- January 3rd, 17th
- February 6th, 22nd
- March 5th, 19th
- April 2nd, 16th
- May 7th, 21st
- June 4th, 18th
- July 2nd, 16th
- August 6th, 20th
- September 4th, 17th
- October 1st, 15th
- November 5th, 19th
- December 3rd, 17th

and BE IT FURTHER

RESOLVED, that such meetings shall begin with the public comment period at 6:45 P.M. and the meetings proper will begin immediately thereafter, and BE IT FURTHER

RESOLVED, that the Town Clerk be and hereby is directed to forward copies of this resolution to the Cheektowaga Bee, Buffalo News and Metro Source, and BE IT FURTHER

RESOLVED, that the above meeting dates shall be posted on the Town's website.

RESULT:	ADOPTED [UNANIMOUS]
MOVER:	Mary Holtz, Supervisor
SECONDER:	James Rogowski, Councilmember
AYES:	Holtz, Jaworowicz, Swiatek, Rogowski, Zydel, Markel, Kaznowski



12. RESOLUTION 2011-657

Call for Public Hearing for 2012 Community Development Block Grant Program

Sponsored By: Councilmember Markel, Councilmember Kaznowski

WHEREAS, the Town is eligible to receive approximately \$850,000 in Community Development Block Grant funds and approximately \$207,974 in Home Investment Partnership program funds for the 2012 Program Year, and

WHEREAS, the Town is required to hold public hearings to obtain the views of Town residents, public agencies and other interested parties on housing and community development needs in the Town, and

WHEREAS, activities proposed for funding with Program Year 2012 Community Development Block Grant and HOME Program funds have been made available for public review in the public libraries within the Town, the Cheektowaga Town Clerk's Office and the Community Development Office, NOW, THEREFORE, BE IT

RESOLVED, that a public hearing be held on January 17, 2012 at 6:45 P.M. at Cheektowaga Town Hall, 3301 Broadway, Cheektowaga, New York 14227 for the above stated purpose, and BE IT

FURTHER RESOLVED, that the attached public notice of such public hearing be published in the Cheektowaga Bee on Thursday, January 5, 2012.

Notice of Public Hearing
Town of Cheektowaga FY 2012 Annual Plan
Community Development Block Grant / HOME Programs

A public hearing will be held on Tuesday, January 17, 2012 at 6:45 P.M. at Cheektowaga Town Hall, 3301 Broadway, Cheektowaga, NY 14227 on the Town's Fiscal Year 2012 Annual Plan for the Community Development Block Grant (CDBG) and HOME Investment Partnership Act (HOME) Programs to obtain the views of citizens and interested parties on housing and community development needs in the Town and on the draft Action Plan which has been made available for public review in Cheektowaga Branch Libraries. The Annual Plan outlines housing and community development projects proposed to be funded with FY 2012 CDBG and HOME Program funds. The Town is eligible to receive approximately \$850,000 in CDBG funds and approximately \$207,974 in HOME Investment Partnership Program funds from HUD in 2012. The Town estimates approximately \$250,000 in program income from its revolving housing rehabilitation loan program and \$300,000 in economic development revolving business loan program income will be received. Those wishing to offer comments at the hearing are asked to also submit a written text, which may also be submitted to the Cheektowaga Community Development Office, 275 Alexander Avenue, Cheektowaga, New York, 14211. Interpreters will be made available at the meetings upon prior request to sign for the hearing impaired. If you need such special arrangements, contact the Cheektowaga Community Development Office at 897-7200, Ext. 6, at least seven (7) business days prior to the hearing. The hearing location is accessible to the physically disabled.

RESULT:	ADOPTED [UNANIMOUS]
MOVER:	Charles Markel, Councilmember
SECONDER:	Stanley Kaznowski, Councilmember
AYES:	Holtz, Jaworowicz, Swiatek, Rogowski, Zydel, Markel, Kaznowski



13. RESOLUTION 2011-658

Authorize Town Clerk to Issue New/Renewal Ambulance Drivers/Attendants Licenses

Sponsored By: Councilmember Jaworowicz, Councilmember Zydel

WHEREAS, on the 7th day of May, 1984, this Town Board adopted an Ambulance Ordinance. The EMS Board, which was created at that time, has completed a review and evaluation of new/renewal license applications for driver(s)/attendant(s), and has recommended that the Town Board issue such licenses, NOW, THEREFORE BE IT

RESOLVED, that the recommendations of the EMS Board concerning the licensing of new/renewal driver(s)/attendant(s) shown on the list below be and hereby are accepted and approved, for a period to expire upon the expiration of such ambulance driver(s)/attendant(s) Emergency Medical Technician ('EMT') card and, BE IT FURTHER

RESOLVED, that the Town Clerk be and hereby is authorized, empowered and directed to issue new/renewal licenses to the driver(s)/attendant(s) set forth on the annexed schedule, pursuant to the terms of this resolution.

TOWN OF CHEEKTOWAGA DRIVER/ATTENDANT LICENSE LIST

<u>Name</u>	<u>Expiration Date</u>
Adam, Wyatt L , ,	7/31/2013
Averion, Sara A , ,	6/30/2014
Bellavia, Frank P , ,	10/31/2014
Blanar, Chad B , ,	12/31/2013
Borkenhagen, Derrick W. , ,	8/31/2014
Buczowski, Craig J , ,	8/31/2014
Burke, Peter J , ,	1/31/2013
Burt, Eric A , ,	10/31/2014
Cassick, Aaron J , ,	12/31/2013
Cody, Matthew D , ,	6/30/2014
Collana, Luigi GM , ,	12/31/2013
Conboy, Mark C , ,	7/31/2012
DiMartino, Philip J , ,	12/31/2013
Dysard, Andrew D. , ,	7/31/2014
Embry, Cassandra N , ,	3/31/2013
Failla, Jack A , ,	2/28/2013
Goudy, Jessica K , ,	11/30/2014

Haber, Steven	, ,	6/30/2012
Hanson, Jessica A	, ,	7/31/2013
Hastreiter, Amy C	, ,	6/30/2014
Hunt, John L	, ,	10/31/2014
Janiga, Justin J	, ,	9/30/2014
Lindstrom, Nicholas M	, ,	6/30/2014
Lloyd, David R	, ,	9/30/2013
Lynch, Richard T	, ,	1/31/2013
Maess, David A	, ,	11/30/2013
Manning, Patrick S	, ,	9/30/2014
McIntyre, Shawn M	, ,	9/30/2014
Nelson, Richard R	, ,	10/31/2014
Niemira, Shawn D	, ,	9/30/2013
Oliver, Christopher F	, ,	8/31/2014
Pfeifer, Robert	, ,	1/31/2014
Pless, Jason M	, ,	6/30/2012
Pullano, Jeremy M	, ,	9/30/2014
Rath, Gregory J	, ,	10/31/2014
Reynolds, Patrick W	, ,	2/28/2014
Rogers, Lyndsay K	, ,	6/30/2014
Rudroff, David J	, ,	9/30/2013
Schmidt, Nathan J	, ,	7/31/2014
Servis, Elizabeth R	, ,	9/30/2014
Sporski, Daren M	, ,	1/20/2012
Stepanski, Thomas J.	, ,	3/31/2013
Stoddard, Kyle M	, ,	2/28/2014
Szczepaniak, Thomas D	, ,	10/31/2013
Taylor, Joshua T	, ,	6/30/2014
Vaarwerk, Stephanie M	, ,	7/31/2012
White, Tiffany M	, ,	10/31/2014
Young, Dorian L	, ,	6/30/2014
Yunusov, Bekhzod N	, ,	6/30/2014

RESULT:	ADOPTED [UNANIMOUS]
MOVER:	Patricia Jaworowicz, Councilmember
SECONDER:	Richard Zydel, Councilmember
AYES:	Holtz, Jaworowicz, Swiatek, Rogowski, Zydel, Markel, Kaznowski



14. RESOLUTION 2011-659

Approve Purchase of Equipment for Police/Courts Building Under New York State Contract

Sponsored By: Supervisor Holtz, Councilmember Swiatek

WHEREAS, the Department of Information Support Services (DISS) requires certain telecommunications equipment including switches, transceiver modules, fiber patch cable and fiber optic cable for installation in the Police and Courts Building (Dispatch Center) presently under construction; and

WHEREAS, CDW Government, Inc., (CDW-G) is an approved distributor of the required equipment under New York State Contract No. PT64525 (Award 21350); and

WHEREAS, CDW Government, Inc. has submitted a quotation for the cost of said equipment to the Town in the amount of \$36,192.78, said cost being New York State Contract pricing; NOW, THEREFORE, BE IT

RESOLVED, that this Town Board hereby approves the purchase of said equipment above referenced for installation in the Police and Courts Building presently under construction from CDW Government, Inc., 200 N. Milwaukee Avenue, Vernon Hills, IL, 60061, for the sum of \$36,192.78; and BE IT FURTHER

RESOLVED, that the Supervisor be and hereby is authorized and directed to execute all documents required to effectuate the purchase of the aforesaid equipment; and BE IT FURTHER

RESOLVED, that the funds for this purchase shall be appropriated from budget line item number 500-1440-2528-5025.

RESULT:	ADOPTED [UNANIMOUS]
MOVER:	Mary Holtz, Supervisor
SECONDER:	Jeff Swiatek, Councilmember
AYES:	Holtz, Jaworowicz, Swiatek, Rogowski, Zydel, Markel, Kaznowski



15. RESOLUTION 2011-660

Approve STOP-DWI Agreement with Erie County for 2011-13

Sponsored By: Councilmember Jaworowicz, Councilmember Rogowski

WHEREAS, the County of Erie, pursuant to the authority granted to it by Article 43-A of the Vehicle and Traffic Law of the State of New York, has established a special options program for driving while intoxicated ("STOP-DWI"), and

WHEREAS, said program provides for the coordination of county, town, city and village efforts to reduce alcohol-related traffic accidents, including improvements in law enforcement and adjudication, increased education and other related activities, and

WHEREAS, Erie County has prepared and submitted to the Town for its approval a STOP-DWI Contract for calendar years 2011-2013, and

WHEREAS, the Town of Cheektowaga is interested in availing itself of funding under the STOP-DWI program and is also desirous of coordinating its efforts to reduce alcohol-related traffic injuries and fatalities with the County of Erie, NOW, THEREFORE, BE IT

RESOLVED, that the Town of Cheektowaga enter into the STOP-DWI Agreement which commences on January 1, 2011 and terminates on December 31, 2013 with the County of Erie concerning its STOP-DWI program, and BE IT FUTRHER

RESOLVED, tat the Supervisor be and hereby is authorized and directed to execute four (4) copies of the STOP-DWI Agreement and any and all other papers necessary to implement the terms of this Agreement.

RESULT:	ADOPTED [UNANIMOUS]
MOVER:	Patricia Jaworowicz, Councilmember
SECONDER:	James Rogowski, Councilmember
AYES:	Holtz, Jaworowicz, Swiatek, Rogowski, Zydel, Markel, Kaznowski



16. RESOLUTION 2011-661

Authorize Supervisor to Execute Agreements for Nutrition Program for the Elderly for 2012

Sponsored By: Supervisor Holtz, Councilmember Swiatek

WHEREAS, the Town of Cheektowaga operates nutrition programs for the elderly at the following facilities in the Town of Cheektowaga:

Infant of Prague Parish, 921 Cleveland Drive
 Cayuga Village Apartments Community Center, 100 Hutchens Drive
 Maryvale East Management Corp., 100 Moorman Drive
 Bell Tower Senior Apartments, 893 French Road/42 Haley Lane
 Southwind Landing Senior Apartments, 5074 Transit Road
 Cheektowaga Senior Center, 3349 Broadway

and,

WHEREAS, agreements between the Town of Cheektowaga and the owners of the above facilities have been drafted relative to the continuation of the operation of said nutrition programs for the year 2012, and

WHEREAS, the County of Erie provides financing for such nutrition programs; and an agreement between the Town of Cheektowaga and the County of Erie has been drafted relative to the operation of such nutrition programs for the year 2012, NOW, THEREFORE, BE IT

RESOLVED, that the Supervisor be and hereby is authorized and directed to execute the above referenced agreements on behalf of the Town.

RESULT:	ADOPTED [UNANIMOUS]
MOVER:	Mary Holtz, Supervisor
SECONDER:	Jeff Swiatek, Councilmember
AYES:	Holtz, Jaworowicz, Swiatek, Rogowski, Zydel, Markel, Kaznowski



17. RESOLUTION 2011-662

Authorize Supervisor to Execute Agreement with Erie County for Transportation Services for the Elderly

Sponsored By: Supervisor Holtz, Councilmember Jaworowicz

WHEREAS, the Town of Cheektowaga, in concert with the County of Erie, has for years been operating a transportation program for the elderly utilizing vans, and

WHEREAS, the County of Erie has prepared and submitted to the Town an agreement between the Town of Cheektowaga and the County of Erie relative to the operation of said transportation program for the Year 2012, and

WHEREAS, the Town of Cheektowaga wishes to continue to offer this service to our Town residents, NOW, THEREFORE, BE IT

RESOLVED, that the Supervisor be and hereby is authorized and directed to execute the above referenced agreement on behalf of the Town.

RESULT:	ADOPTED [UNANIMOUS]
MOVER:	Mary Holtz, Supervisor
SECONDER:	Patricia Jaworowicz, Councilmember
AYES:	Holtz, Jaworowicz, Swiatek, Rogowski, Zydel, Markel, Kaznowski



18. RESOLUTION 2011-663

Acceptance of Maintenance and Easement Agreements from the Pyramid Walden Company, L.P.

Sponsored By: Supervisor Holtz, Councilmember Swiatek

WHEREAS, as part of the process for the recent expansion of the Walden Galleria Mall, the Pyramid Walden Company, L.P. made certain commitments concerning public improvements along Galleria Drive, and

WHEREAS, the following referenced agreements relating to these commitments were prepared by the Town Attorney and have been signed by a representative of Pyramid Walden Company, L.P.:

1. Sidewalk Maintenance Agreement;
2. Sidewalk Easement;
3. Bill of Sale for Pedestrian Bridge;
4. Permit for Installation and Maintenance of Traffic Signal on Galleria Drive at Midway Drive;
5. Agreement to permit the Town to place its street light bracket/arm and luminaire on Pyramid's traffic signal pole.

, and

WHEREAS, said documents are acceptable to the Town Engineer and this Town Board, NOW, THEREFORE, BE IT

RESOLVED, that this Town Board hereby accepts the above referenced documents, and BE IT FURTHER

RESOLVED, that the Supervisor be and hereby is authorized and directed to execute said documents in behalf of the Town of Cheektowaga.

RESULT:	ADOPTED [UNANIMOUS]
MOVER:	Mary Holtz, Supervisor
SECONDER:	Jeff Swiatek, Councilmember
AYES:	Holtz, Jaworowicz, Swiatek, Rogowski, Zydel, Markel, Kaznowski



19. RESOLUTION 2011-664

Appointment of Clerk Typist (Competitive/Permanent) Department of Youth & Recreational Services/Michele L. Oldfield

Sponsored By: Councilmember Swiatek, Supervisor Holtz

WHEREAS, a vacancy exists in the title of Clerk Typist in the Department of Youth and Recreational Services; AND

WHEREAS, notice of said vacancy has been posted in accordance with the provisions of the Town's collective bargaining agreement with the Town of Cheektowaga Employees Association; AND

WHEREAS, no full-time employee bid on said vacancy; AND

WHEREAS, said title falls under the competitive class of Erie County Civil Service; AND

WHEREAS, a current civil service list exists for said title; AND

WHEREAS, said civil service list was canvassed and interviews conducted; AND

WHEREAS, Michele L. Oldfield appears on said list and meets all the necessary qualifications for appointment; NOW, THEREFORE, BE IT

RESOLVED, Michele L. Oldfield of Cheektowaga, New York, be and hereby is appointed to the position of Clerk Typist in the Department of Youth and Recreational Services in accordance with the terms and conditions of the Town's collective bargaining agreement with the Town of Cheektowaga Employees Association effective January 3, 2012.

RESULT:	ADOPTED [UNANIMOUS]
MOVER:	Jeff Swiatek, Councilmember
SECONDER:	Mary Holtz, Supervisor
AYES:	Holtz, Jaworowicz, Swiatek, Rogowski, Zydel, Markel, Kaznowski



20. RESOLUTION 2011-665

Appointment of Student Intern (Police Department)/Jeffrey M. Brown

Sponsored By: Councilmember Jaworowicz, Councilmember Swiatek

WHEREAS, Jeffrey M. Brown, a student at Hilbert College, has requested to participate in the student internship program at the Police Department; AND

WHEREAS, this individual has been interviewed by the Police Department and the Police Department is willing to afford him the opportunity to intern in the Police Department; NOW, THEREFORE, BE IT

RESOLVED, that Jeffrey M. Brown of Lancaster, New York, be and hereby is authorized to participate as an unpaid intern in the Police Department, subject to his execution of a Waiver of Liability and Agreement of Confidentiality; AND, BE IT FURTHER

RESOLVED, that Mr. Brown's internship be and hereby is effective January 1, 2012 through May 31, 2012; AND, BE IT FURTHER

RESOLVED, that the Supervisor be and hereby is authorized and directed to execute the Agreement of Confidentiality, and all other documents necessary to effectuate this student internship in the Police Department.

RESULT:	ADOPTED [UNANIMOUS]
MOVER:	Patricia Jaworowicz, Councilmember
SECONDER:	Jeff Swiatek, Councilmember
AYES:	Holtz, Jaworowicz, Swiatek, Rogowski, Zydel, Markel, Kaznowski



21. RESOLUTION 2011-666

Transfer of Maintenance Worker (Non-Competitive/Permanent) to Traffic Maintenance Worker (Non-Competitive/Permanent) Police Department (Sign Maintenance Division)/Frank P. Piacente

Sponsored By: Councilmember Jaworowicz, Councilmember Swiatek

WHEREAS, the Town wishes to transfer Frank P. Piacente, currently employed as a Maintenance Worker in the Police Department (Sign Maintenance Division) to that of Traffic Maintenance Worker in the Police Department (Sign Maintenance Division); AND

WHEREAS, this transfer will result in no adjustment in salary pursuant to the collective bargaining agreement between the Town and the Town of Cheektowaga Employees Association; NOW, THEREFORE, BE IT

RESOLVED, that Frank P. Piacente of Cheektowaga, New York, be and hereby is transferred from the title of Maintenance Worker in the Police Department (Sign Maintenance Division) to that of Traffic Maintenance Worker in the Police Department (Sign Maintenance Division) effective December 20, 2011.

RESULT:	ADOPTED [UNANIMOUS]
MOVER:	Patricia Jaworowicz, Councilmember
SECONDER:	Jeff Swiatek, Councilmember
AYES:	Holtz, Jaworowicz, Swiatek, Rogowski, Zydel, Markel, Kaznowski



22. RESOLUTION 2011-667

Hire/Termination of Part-Time/Seasonal Employees

Sponsored By: Councilmember Swiatek, Supervisor Holtz

BE IT RESOLVED, that the following individuals be and hereby are hired as **PART-TIME EMPLOYEES** in the departments listed, not to exceed nineteen (19) hours on a weekly basis, in compliance with Civil Service Laws and Regulations as well as the provisions of the Town's collective bargaining agreement between the Town of Cheektowaga and the Town of Cheektowaga Employees Association:

POLICE DEPARTMENT Police Attendant \$14.00/hour
Courtney A. Jakubowicz, Cheektowaga, New York
Effective 12/05/11

POLICE DEPARTMENT Police Attendant \$16.10/hour
Michael J. Mingle, Cheektowaga, New York
Effective 12/19/11

POLICE DEPARTMENT Student Assistant \$7.25/hour
Sean T. Szymanski, Cheektowaga, New York
Effective 12/2011

BE IT RESOLVED, that the following seasonal and/or part-time employees be and hereby are terminated as listed:

SANITATION DEPARTMENT
Daniel Pittorf effective 12/10/11
Michael McGloin effective 12/10/11

JUSTICE COURT
Martha DiGiacomo effective 12/23/11

FACILITIES DEPARTMENT
Mark D. Superczynski effective 11/07/11
Matthew J. Pazderski effective 10/29/11

POLICE DEPARTMENT
Madeline E. Pignatora effective 9/19/11

Motion by Councilmember Rogowski; Seconded by Councilmember Markel to waive the reading of names for this resolution. Motion Carried.

RESULT: ADOPTED [UNANIMOUS]
MOVER: Jeff Swiatek, Councilmember
SECONDER: Mary Holtz, Supervisor

AYES: Holtz, Jaworowicz, Swiatek, Rogowski, Zydel, Markel, Kaznowski



23. RESOLUTION 2011-668

Travel Authorization Council Office/Councilmembers-Elect Angela M. Wozniak and Gerald P. Kaminski, Sr.

Sponsored By: Councilmember Swiatek, Supervisor Holtz

WHEREAS, the 2012 Training School for Newly Elected Town Officials is being held January 4 through January 6, 2012 in Rochester, New York; AND

WHEREAS, Councilmembers-Elect Angela M. Wozniak and Gerald P. Kaminski, Sr., have requested authorization to attend said training school; AND

WHEREAS, the total cost to the Town shall not exceed \$670; AND

WHEREAS, these expenses have been budgeted by the Town; NOW, THEREFORE, BE
IT

RESOLVED, that Councilmembers -Elect Angela M. Wozniak and Gerald P. Kaminski, Sr., be and hereby are authorized to attend the 2012 Training School for Newly Elected Town Officials being held January 4 through January 6, 2012 in Rochester, New York.

RESULT:	ADOPTED [UNANIMOUS]
MOVER:	Jeff Swiatek, Councilmember
SECONDER:	Mary Holtz, Supervisor
AYES:	Holtz, Jaworowicz, Swiatek, Rogowski, Zydel, Markel, Kaznowski

IV. Communications

A. Departmental Communications

1. Supervisor's Statement of Funds - October 2011
2. Minutes: Cheektowaga Traffic Safety Commission - November 15, 2011

B. General Communications

1. Notice of Claim: Nicholas R. Willard Vs. Town of Cheektowaga

V. Comments

A. Supervisor's Comments

B. Councilmember's Comments

C. Public Comments

VI. Adjournment

Motion by Supervisor Holtz; Seconded by Councilmember Rogowski to exit the meeting and enter into Executive Session. Motion Carried. Time of adjournment was 7:07 PM.

Alice Magierski, Town Clerk



Town of Cheektowaga

Work Session

~ Minutes ~

3301 Broadway
Cheektowaga, NY 14227
<http://www.town.cheektowaga.ny.us>

Alice Magierski
716-686-3400

Tuesday, December, 27, 2011

6:00 PM

Council Office

I. Call to Order

6:00 PM Meeting called to order on December 27, 2011 at Council Office, Conference Room, Cheektowaga, NY.

Attendee Name	Organization	Title	Status	Arrived
Mary Holtz	Town of Cheektowaga	Supervisor	Present	
Patricia Jaworowicz	Town of Cheektowaga	Councilmember	Present	
Jeff Swiatek	Town of Cheektowaga	Councilmember	Present	
James Rogowski	Town of Cheektowaga	Councilmember	Present	
Richard Zydel	Town of Cheektowaga	Councilmember	Present	
Charles Markel	Town of Cheektowaga	Councilmember	Present	
Stanley Kaznowski	Town of Cheektowaga	Councilmember	Present	

2. Additional Attendees

Brian Krause, Director of Finance and Administration
Anthony Romano, Coordinator of Employee Relations
Kevin Schenk, Town Attorney
Gerald Kaminski, Sr., Councilmember-Elect
Angela Wozniak, Councilmember-Elect

II. Resolutions



1. RESOLUTION 2011-669

Adopt Local Law No. 2 of the Year 2011 - a Local Law to Amend the Zoning Map to Rezone 2480 and Part of 2490-2550 Walden Avenue

Sponsored By: Markel, Kaznowski, Holtz, Jaworowicz, Swiatek, Rogowski, Zydel

WHEREAS, Benderson Development Company, LLC petitioned for a rezoning from M1-Light Manufacturing District to CM-General Commercial District for property owned by it and located at 2480 Walden Avenue and Part of 2490-2550 Walden Avenue, Cheektowaga, New York, and

WHEREAS, a public hearing on such proposed amendment to the Zoning Map was held before this Town Board on the 20th day of June, 2011 at 6:30 P.M., after publication and service of the notices required by the provisions of the Code of the Town of Cheektowaga ("Zoning Law"), Town Law and the Municipal Home Rule Law; and

WHEREAS, the Cheektowaga Planning Board reviewed such application and recommended approval thereof, and

WHEREAS, this Town Board previously issued a Negative Declaration under SEQRA and the Town Environmental Impact Review Ordinance for this rezoning (Resolution 2011-631), and

WHEREAS, said rezoning was approved by Town Board Resolution 2011-632, and

WHEREAS, said resolution needs to be amended to note that it was adopted as Local Law No. 2 of the Year 2011 entitled "A Local Law to Amend the Town Zoning Map to Rezone 2480 and Part of 2490-2550 Walden Avenue", NOW, THEREFORE, BE IT

RESOLVED, that Resolution 2011-632 be and hereby is amended to provide as follows:

RESOLVED, that Local Law No. 2 of the Year 2011 entitled " A Local law to Amend the Town Zoning Map to Rezone 2480 and Part of 2490-2550 Walden Avenue", which is attached hereto and made a part hereof, be and the same is hereby enacted, and BE IT FURTHER

RESOLVED, that Local Law No. 2 of the Year 2011 shall be effective upon filing with the Secretary of State, and BE IT FURTHER

RESOLVED, that the Town Clerk shall file one (1) certified copy of this local law in her office and one (1) certified copy with the Secretary of State.

LOCAL LAW NO. 2 OF THE YEAR 2011
A LOCAL LAW TO AMEND THE
ZONING MAP TO REZONE 2480 AND PART OF 2490-2550 WALDEN AVENUE

The Official Zoning Map of the Town of Cheektowaga, as referenced in Section 260-5 of the Zoning Law, is hereby amended to rezone the following described property known as 2480 and Part of 2490-2550 Walden Avenue from M1-Light Manufacturing District to CM-General Commercial District, subject to the condition that the actual development or site plan must be submitted to this Town Board for approvals:

LEGAL DESCRIPTION OF LANDS TO BE REZONED

ALL THAT TRACT OR PARCEL OF LAND, situate in the Town of Cheektowaga, County of Erie and State of New York, being part of Lot No. 11, Township 11 and Range 7 of the Holland Land Company's Survey and being further bounded and described as follows:

BEGINNING at a point in the east line of Lot No. 11 distant 140 feet south of its intersection with the south line of Zoerb Avenue as laid out on a map filed in the Erie County Clerk's office under Map Cover No. 2146;

Thence westerly, parallel with the south line of Zoerb Avenue, a distance of 757.89 feet to the True Point and Place of Beginning;

Thence southerly at an interior angle of 89°52'43", a distance of 580.99 feet to a point on the northerly line of said Walden Avenue;

Thence westerly along the northerly line of said Walden Avenue, a distance of 837.63 feet to a point in the west line of lands conveyed to Nathan Rovner by deed recorded in the Erie County Clerk's Office in Liber 5897 of Deeds at page 528;

Thence northerly along the west line of land so conveyed to Nathan Rovner, 986.51 feet to a point 140.0 feet southerly from the intersection of the said west line of Rovner's land with the south line of Zoerb Avenue as laid out on a map filed in the Erie County Clerk's office under Map Cover No. 2146;

Thence easterly, and parallel with the south line of said Zoerb Avenue 827.02 feet to the True point and place of beginning.

This parcel containing 759,351 Sq.Ft. or 17.432 Acres more or less.

RESULT:	ADOPTED [UNANIMOUS]
MOVER:	Charles Markel, Councilmember
SECONDER:	Stanley Kaznowski, Councilmember
AYES:	Holtz, Jaworowicz, Swiatek, Rogowski, Zydel, Markel, Kaznowski



2. RESOLUTION 2011-670

Change Order - Asbestos Survey for 1112 Walden Avenue

Sponsored By: Councilmember Markel, Councilmember Kaznowski

WHEREAS, the contract for a pre-demolition asbestos survey, specifications, and air monitoring services for the demolition of 1112 Walden Avenue was awarded to 56 Services, Inc., by Resolution 2011-4, for the sum of \$1,490.00; and

WHEREAS, through inadvertence, technician time and air monitoring services during said demolition was not reflected therein, and will cost an additional \$975.00; and

WHEREAS, the Town's consultants, Nussbaumer & Clarke, recommend approval of a Change Order for such services; NOW, THEREFORE, BE IT

RESOLVED, that this Town Board hereby approves a Change Order for technician time and air monitoring services regarding the demolition of 1112 Walden Avenue in the amount of \$975.00, and directs the supervisor to execute said Change Order; and be it further

RESOLVED, that moneys for said Change Order shall be appropriated from budget line item number 0800-800-0440.

RESULT:	ADOPTED [UNANIMOUS]
MOVER:	Charles Markel, Councilmember
SECONDER:	Stanley Kaznowski, Councilmember
AYES:	Holtz, Jaworowicz, Swiatek, Rogowski, Zydel, Markel, Kaznowski



3. RESOLUTION 2011-671

Change Order - Asbestos Survey for 2371 Genesee Street

Sponsored By: Councilmember Markel, Councilmember Kaznowski

WHEREAS, the contract for a pre-demolition asbestos survey, specifications, and air monitoring services for the demolition of 2371 Genesee Street was awarded to 56 Services, Inc., by Resolution 2011-5, for the sum of \$925.00; and

WHEREAS, through inadvertence, technician time and air monitoring services during said demolition were not reflected therein, and will cost an additional \$1,625.00; and

WHEREAS, the Town's consultants, Nussbaumer & Clarke, recommend approval of a Change Order for such services; NOW, THEREFORE, BE IT

RESOLVED, that this Town Board hereby approves a Change Order for technician time and air monitoring services regarding the demolition of 2371 Genesee Street in the amount of \$1,625.00, and directs the Supervisor to execute said Change Order; and be it further

RESOLVED, that moneys for said Change Order shall be appropriated from budget line item number 0800-800-0440.

RESULT:	ADOPTED [UNANIMOUS]
MOVER:	Charles Markel, Councilmember
SECONDER:	Stanley Kaznowski, Councilmember
AYES:	Holtz, Jaworowicz, Swiatek, Rogowski, Zydel, Markel, Kaznowski



4. RESOLUTION 2011-672

Retention of Firm to Provide Fire and Security Alarm Services

Sponsored By: Councilmember Rogowski, Councilmember Kaznowski

WHEREAS, the Town of Cheektowaga Facilities Department currently utilizes the services of Fire Safety Systems for fire alarm and security alarm testing and inspection, and

WHEREAS, SimplexGrinnell currently holds the New York State Contract (Contract #PT63104, Group #77201, Award #20191) for these services and is less expensive, and

WHEREAS, SimplexGrinnell will also be utilized for the new Police & Court building under a separate agreement, and it is advantageous to deal with a single company for all Town buildings, and

WHEREAS, the Director of the Facilities Department has obtained the following referenced quotations from SimplexGrinnell for the following services for Calendar Years 2012-2014:

- Annual Fire Alarm and Security Alarm Systems Testing and Inspections, together with Standard Emergency Services to 14 Town-owned buildings - \$5,975.00 per year
- 14-Hour Security Monitoring for 7 buildings, plus Fire & Security Monitoring at the Police Substation, together with preparation of monthly reports for 2 buildings - \$1,700.00 per year

, and

WHEREAS, funding is available in the Facilities Department budget for these services, NOW, THEREFORE, BE IT

RESOLVED, that this Town Board hereby terminates any and all arrangements with Fire Safety Systems for fire alarm and security alarm services at Town Buildings, effective January 1, 2012, and BE IT FURTHER

RESOLVED, that this Town Board hereby retains SimplexGrinnell as per its proposals, to perform fire alarm and security alarm services and indicated above from January 1, 2012 to December 31, 2014, and BE IT FURTHER

RESOLVED, that fees for said services shall be appropriated from budget line item number 100-7110-4451.

RESULT:	ADOPTED [UNANIMOUS]
MOVER:	James Rogowski, Councilmember
SECONDER:	Stanley Kaznowski, Councilmember
AYES:	Holtz, Jaworowicz, Swiatek, Rogowski, Zydel, Markel, Kaznowski



5. RESOLUTION 2011-673

Retention of Health Benefits Program Broker

Sponsored By: Holtz, Swiatek, Rogowski, Zydel, Markel, Jaworowicz, Kaznowski

WHEREAS, the Town of Cheektowaga provides health insurance and other benefits to many of its employees, AND

WHEREAS, there is a need for the Town of Cheektowaga to obtain assistance for from a health care consultant/broker to serve as the Town's benefits broker and to provide consulting services for such benefits, and recommend options to the Town for the design of a benefits program, AND

WHEREAS, the Town solicited proposals from various benefits program consultants, AND

WHEREAS, Lawley Benefits Group, a division of Lawley Insurance, has submitted a proposal to review the Town's existing benefits program, design and recommend an optimal program for the Town, and implement and administer the new benefit program, AND

WHEREAS, this Town Board wishes to utilize the services of Lawley Benefits Group as per its proposal, NOW, THEREFORE, BE IT

RESOLVED, that this Town Board designates Lawley Benefits Group, 361 Delaware Avenue, Buffalo, New York, 14202, its Broker of Record as per its proposal to review the Town's existing benefits program and make recommendations to the Town concerning such benefits program, and BE IT FURTHER

RESOLVED, that, after review and approval of the recommendations of Lawley Benefits Group, this Town Board may retain Lawley Benefits Group. to implement and administer a new health benefits program for the Town of Cheektowaga, and BE IT FURTHER

RESOLVED, that the Supervisor be and hereby is authorized and directed to execute any and all documents required for these services, subject to approval by the Town Attorney's Office.

RESULT:	ADOPTED [UNANIMOUS]
MOVER:	Mary Holtz, Supervisor
SECONDER:	Jeff Swiatek, Councilmember
AYES:	Holtz, Jaworowicz, Swiatek, Rogowski, Zydel, Markel, Kaznowski